



US00D881760S

(12) **United States Design Patent**
McGinley et al.

(10) **Patent No.:** **US D881,760 S**
(45) **Date of Patent:** **** Apr. 21, 2020**

(54) **MOTORCYCLE SEAT FRAME**
(71) Applicant: **Harley-Davidson Motor Company Group, LLC, Milwaukee, WI (US)**
(72) Inventors: **Ben McGinley, Glendale, WI (US); Brad Richards, Grafton, WI (US); Kirk Rasmussen, Springville, UT (US); Kenneth G. Luckjohn, Sheboygan, WI (US); Richard W. Elchert, Mequon, WI (US); Gerald Newman Feldman, Bayside, WI (US)**

D271,867 S * 12/1983 Danielson D12/119
D272,140 S * 1/1984 Turkington D12/119
D287,348 S * 12/1986 Larson D12/119
D332,540 S * 1/1993 Peterson D12/114
D371,529 S * 7/1996 Potter D12/114
D497,332 S * 10/2004 Sugimoto D12/114
6,913,099 B2 * 7/2005 Scott B62J 1/12
180/219
D541,706 S * 5/2007 Goldstein D12/117
7,210,550 B2 * 5/2007 Yonehana B60L 7/12
180/220
D544,409 S * 6/2007 Hutchison D12/114
D628,127 S * 11/2010 LeBlanc D12/119

(Continued)

(73) Assignee: **Harley-Davidson Motor Company Group, LLC, Milwaukee, WI (US)**

Primary Examiner — Darlington Ly

(74) *Attorney, Agent, or Firm* — Michael Best & Friedrich LLP

(**) Term: **15 Years**

(21) Appl. No.: **29/658,272**

(57) **CLAIM**

(22) Filed: **Jul. 30, 2018**

We claim the ornamental design for a motorcycle seat frame, as shown and described.

(51) **LOC (12) Cl.** **12-11**

(52) **U.S. Cl.**
USPC **D12/119**

(58) **Field of Classification Search**
USPC D12/110, 119, 222, 223, 407; D8/349, D8/354; D6/354, 500-502
CPC B62K 11/04; B62K 19/12; B62K 25/04; B62K 25/286; B60K 13/04
See application file for complete search history.

DESCRIPTION

(56) **References Cited**

U.S. PATENT DOCUMENTS

3,741,596 A * 6/1973 Cate B62J 1/28
297/215.11
4,062,585 A * 12/1977 Herring, Jr. B62J 1/02
297/195.1
4,125,285 A * 11/1978 Hanagan B62J 1/12
297/195.12
4,188,697 A * 2/1980 Hanagan B62J 1/12
29/469
D260,251 S * 8/1981 Larose D12/407

FIG. 1 is a front perspective view of a motorcycle seat frame showing our new design;
FIG. 2 is a rear perspective view thereof;
FIG. 3 is a front elevation view thereof;
FIG. 4 is a rear elevation view thereof;
FIG. 5 is a right side elevation view thereof;
FIG. 6 is a left side elevation view thereof;
FIG. 7 is a top plan view thereof;
FIG. 8 is a bottom plan view thereof; and,
FIG. 9 is a rear perspective view thereof as installed on an exemplary motorcycle.

The broken line showing of the motorcycle illustrates environmental structure, while all other broken lines illustrate portions of the motorcycle seat frame. No subject matter shown in broken lines form part of the claimed design.

1 Claim, 9 Drawing Sheets

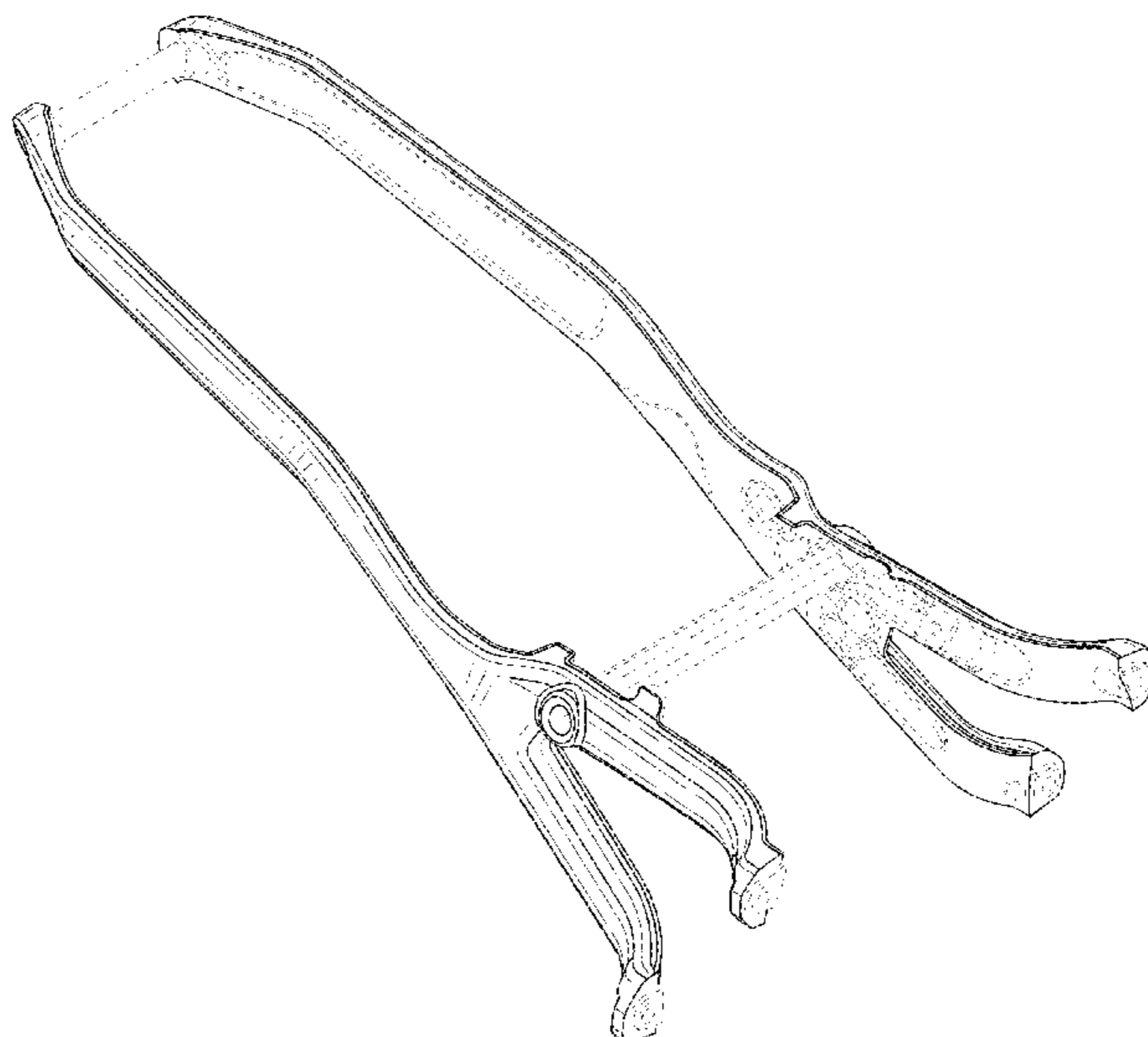

(56)

References Cited

U.S. PATENT DOCUMENTS

D634,254 S * 3/2011 Marlow D12/223
8,079,642 B2 * 12/2011 Suzuki B62K 19/12
180/219
D753,552 S 4/2016 McGinley et al.
9,493,207 B2 * 11/2016 Kawai B62K 25/04
D774,789 S * 12/2016 Yamada D12/114
D807,152 S * 1/2018 Hansen D8/354

* cited by examiner

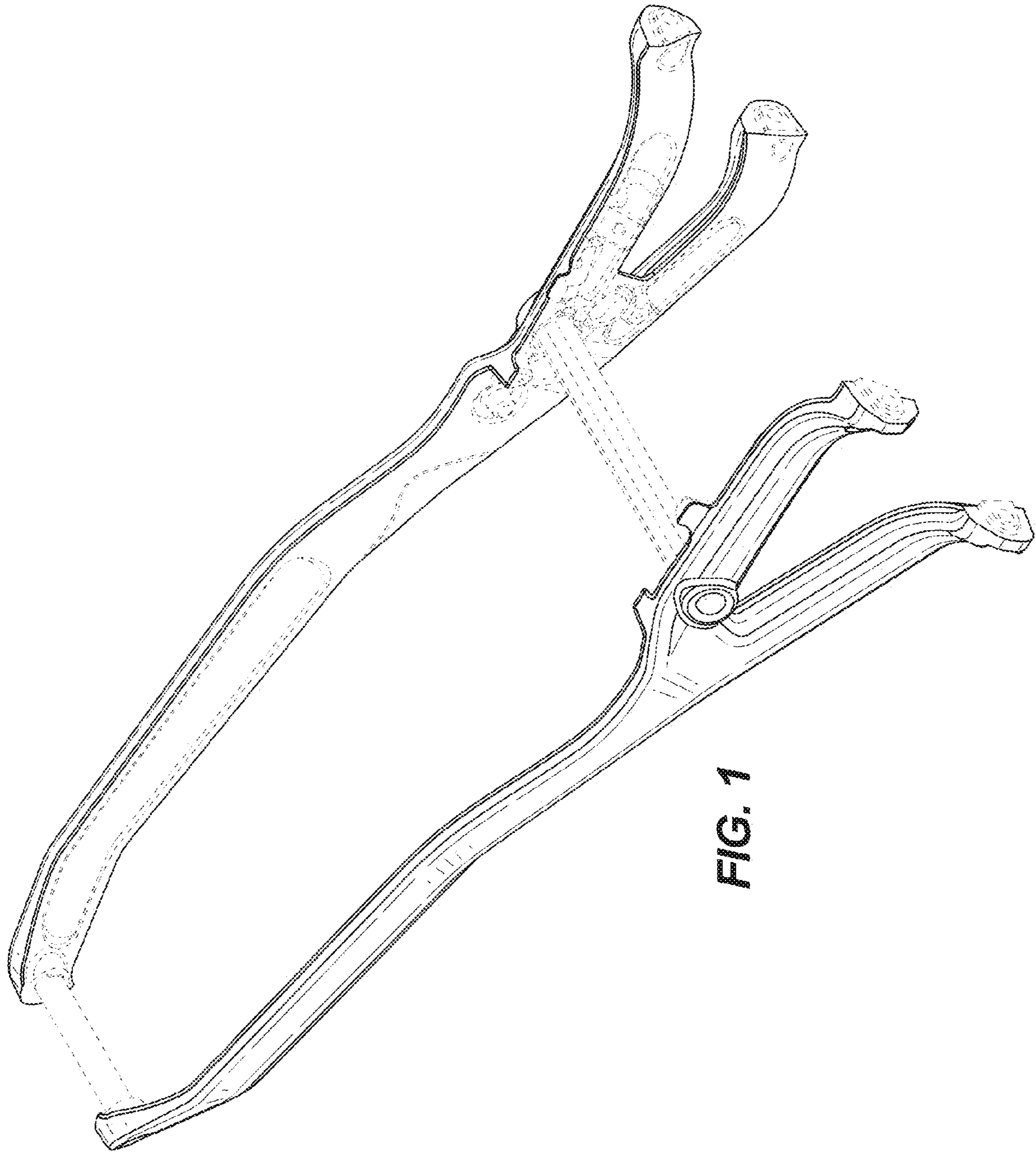

FIG. 1

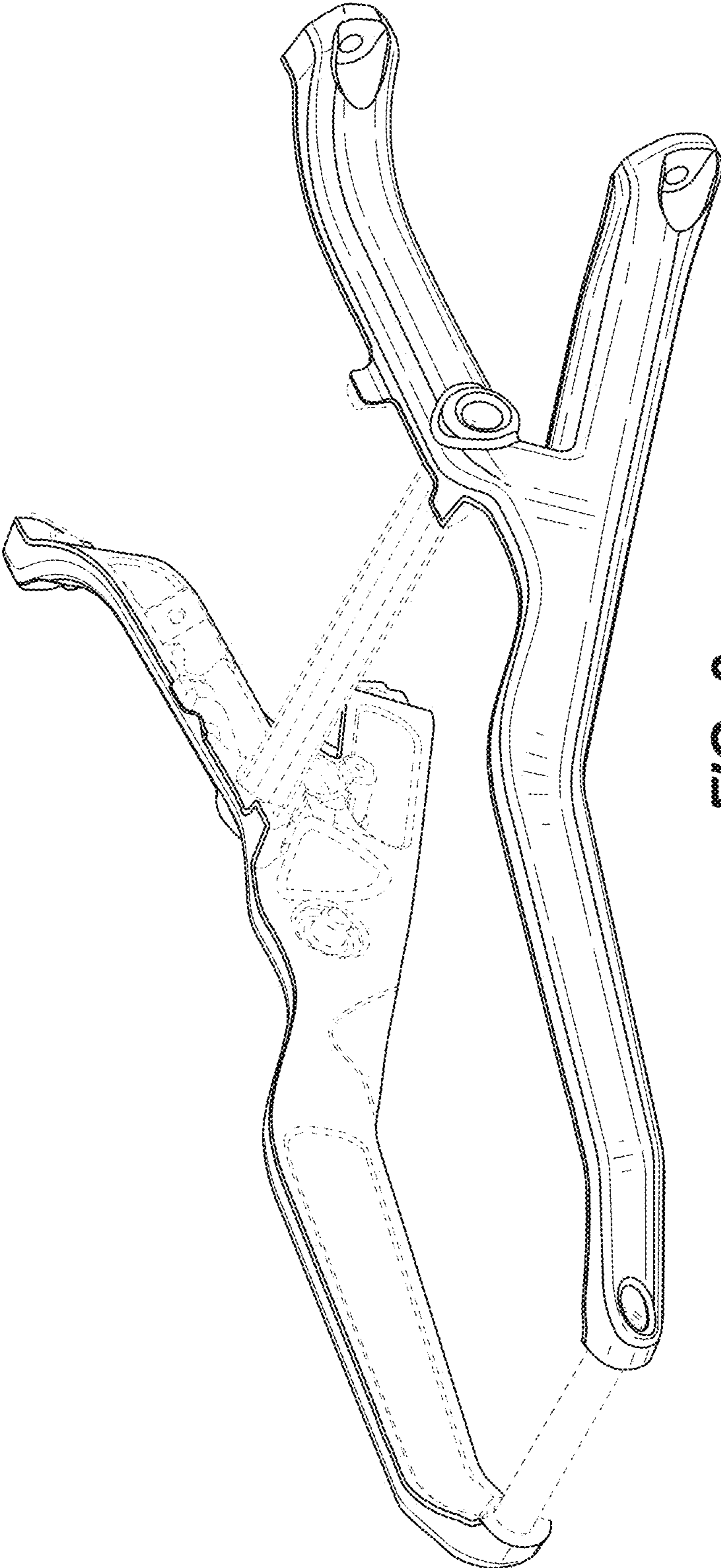

FIG. 2

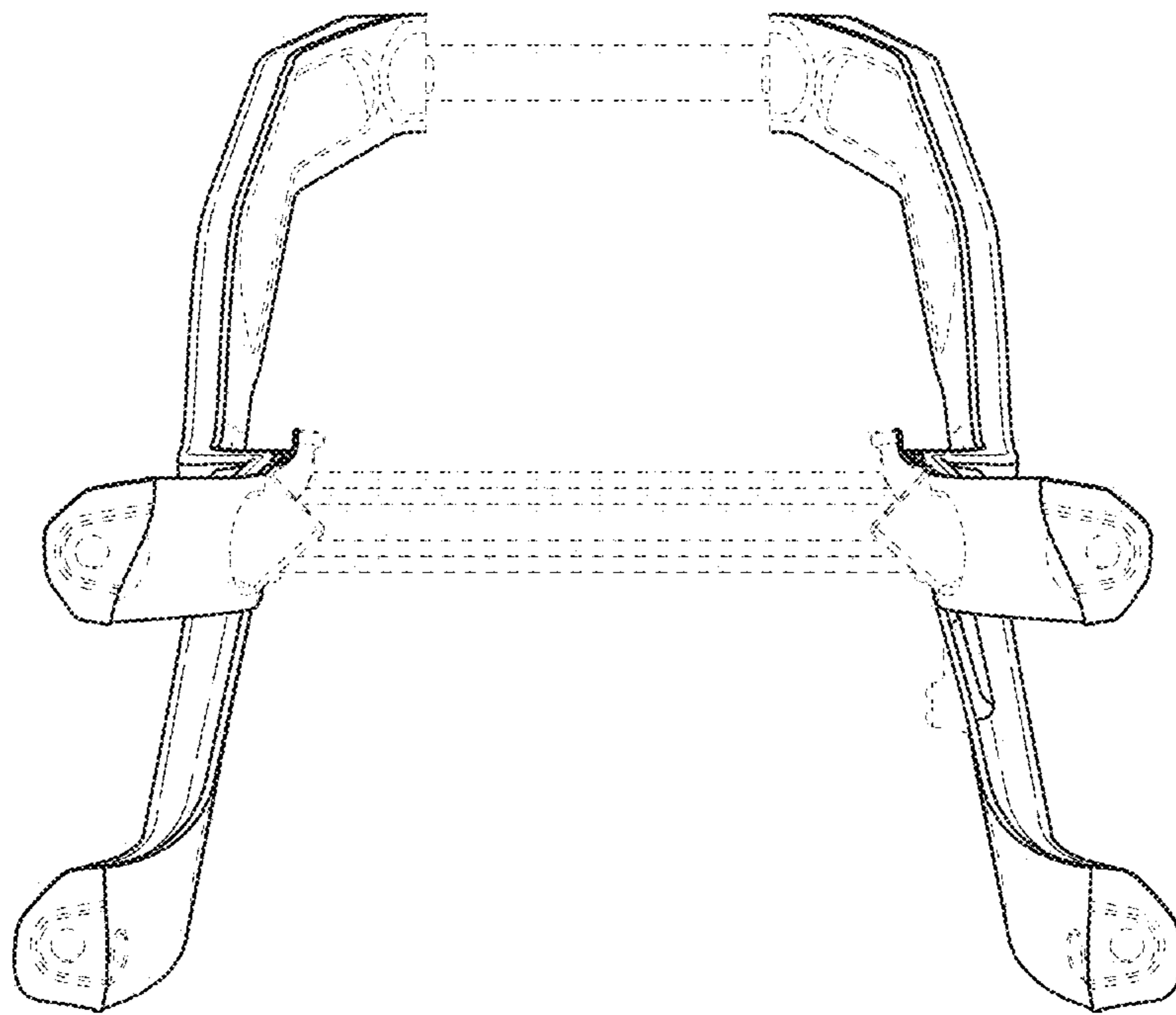

FIG. 3

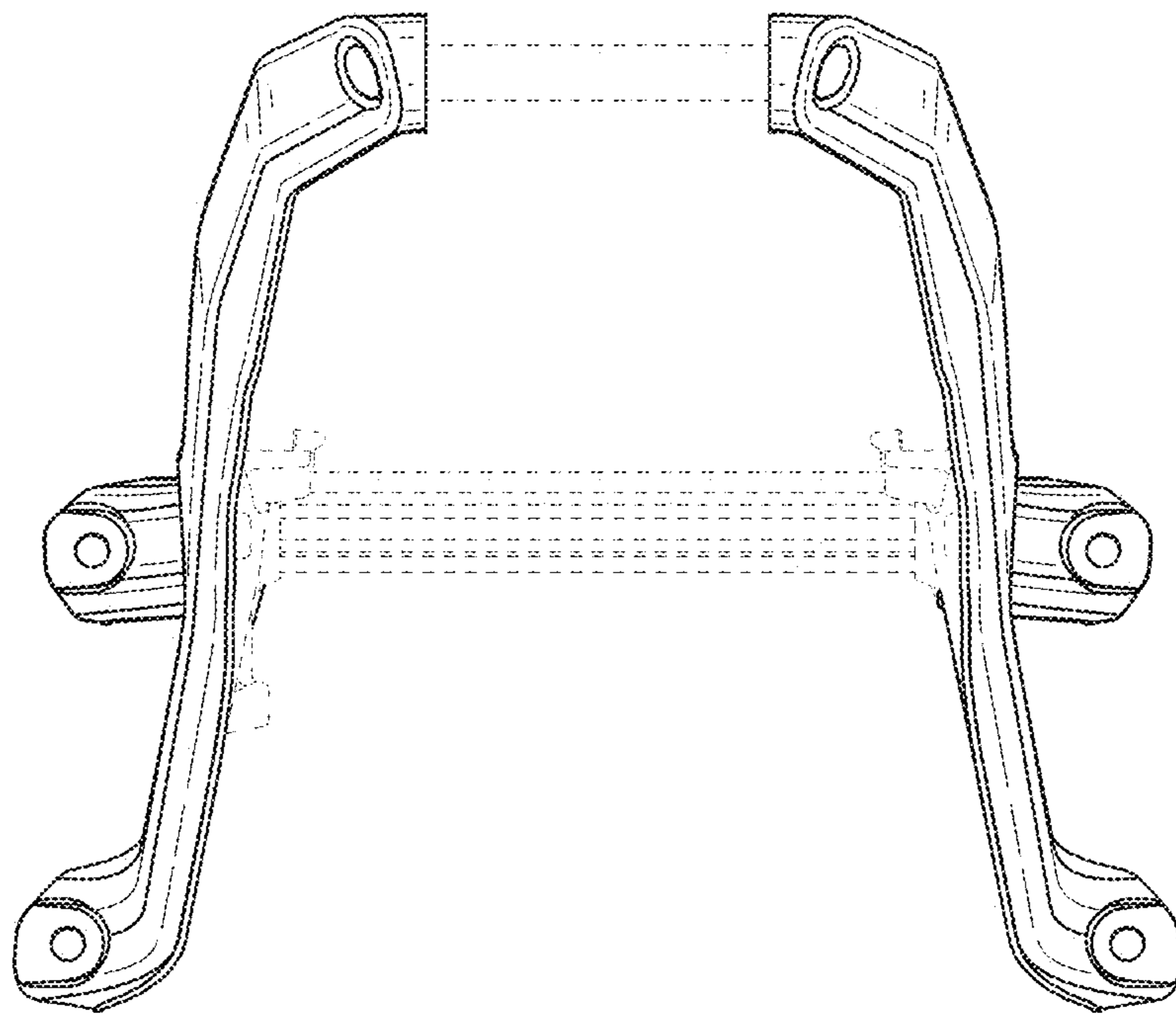

FIG. 4

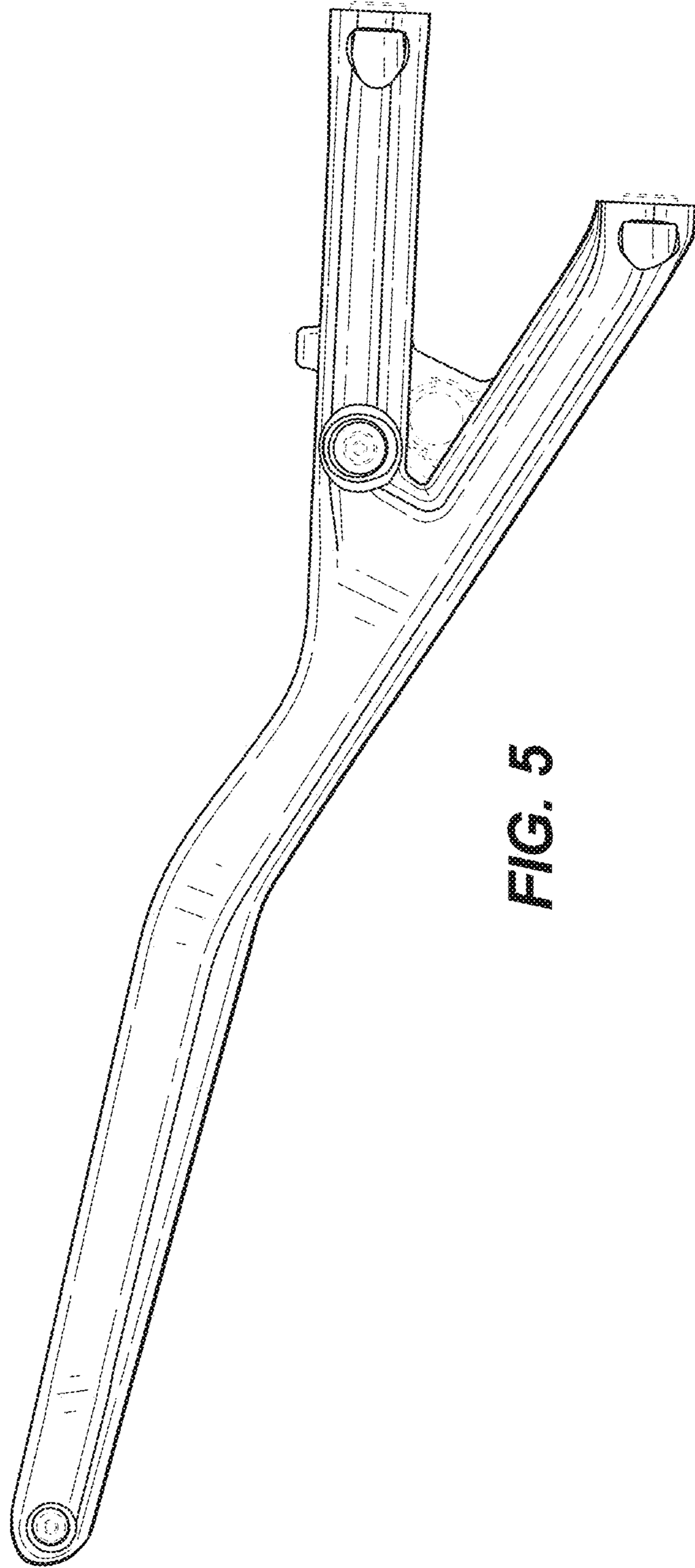

FIG. 5

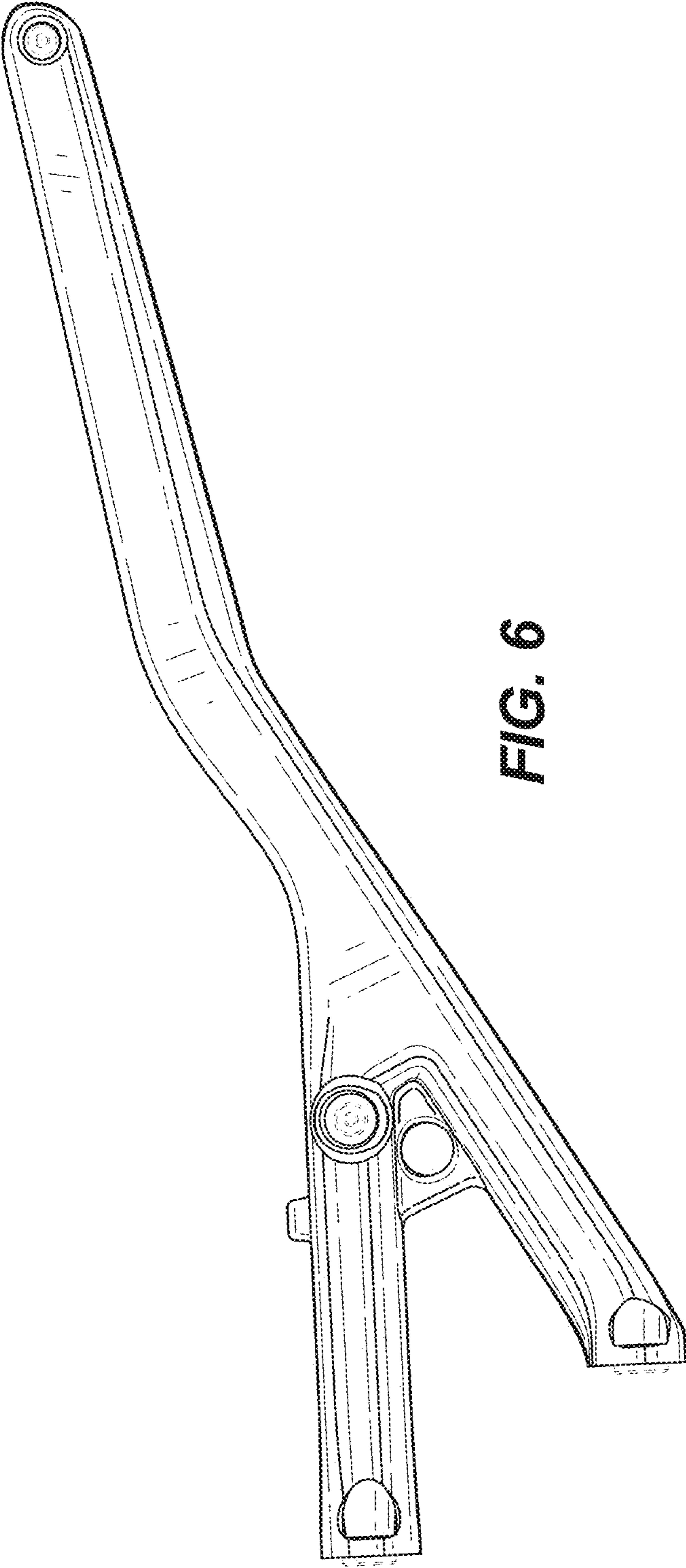

FIG. 6

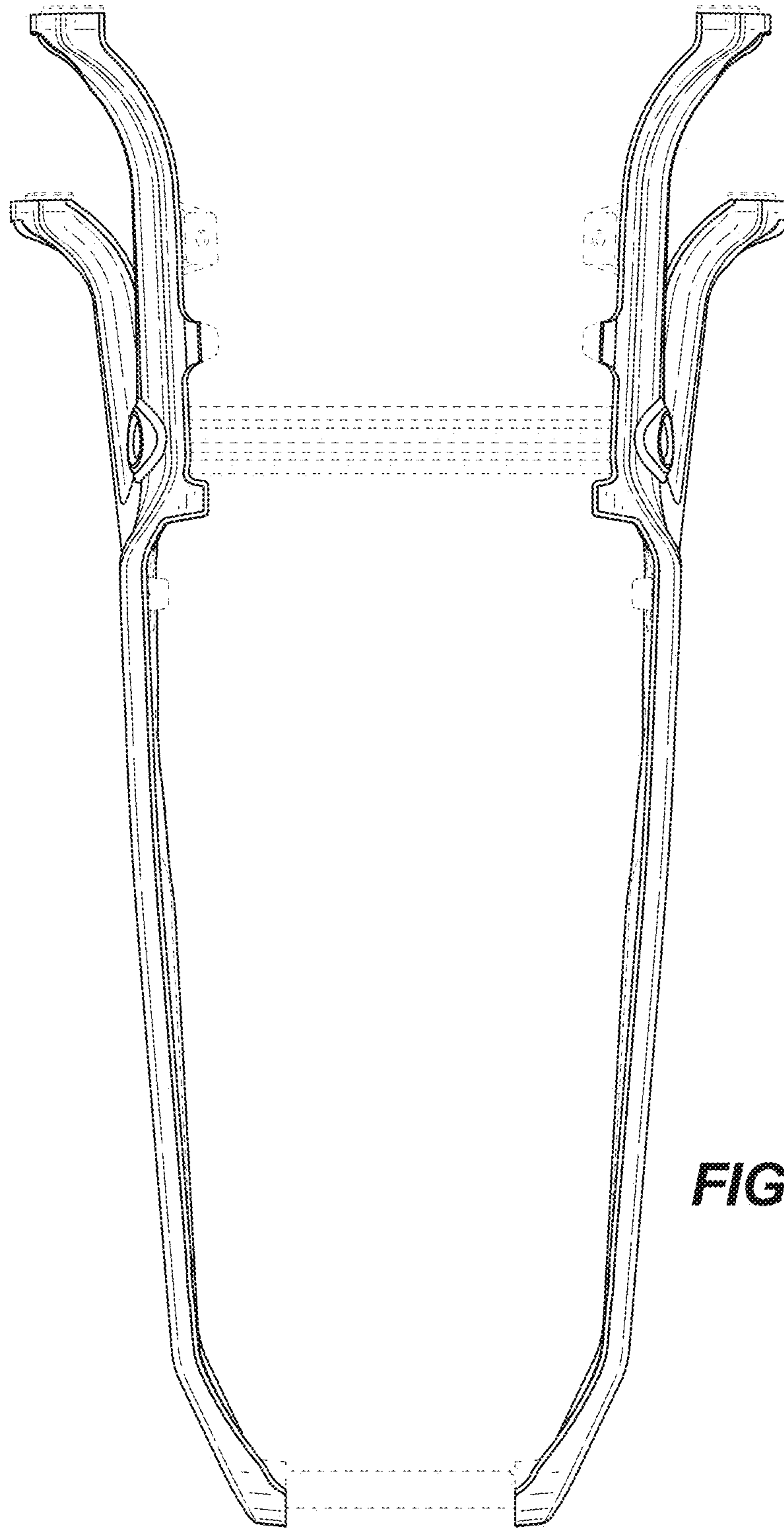

FIG. 7

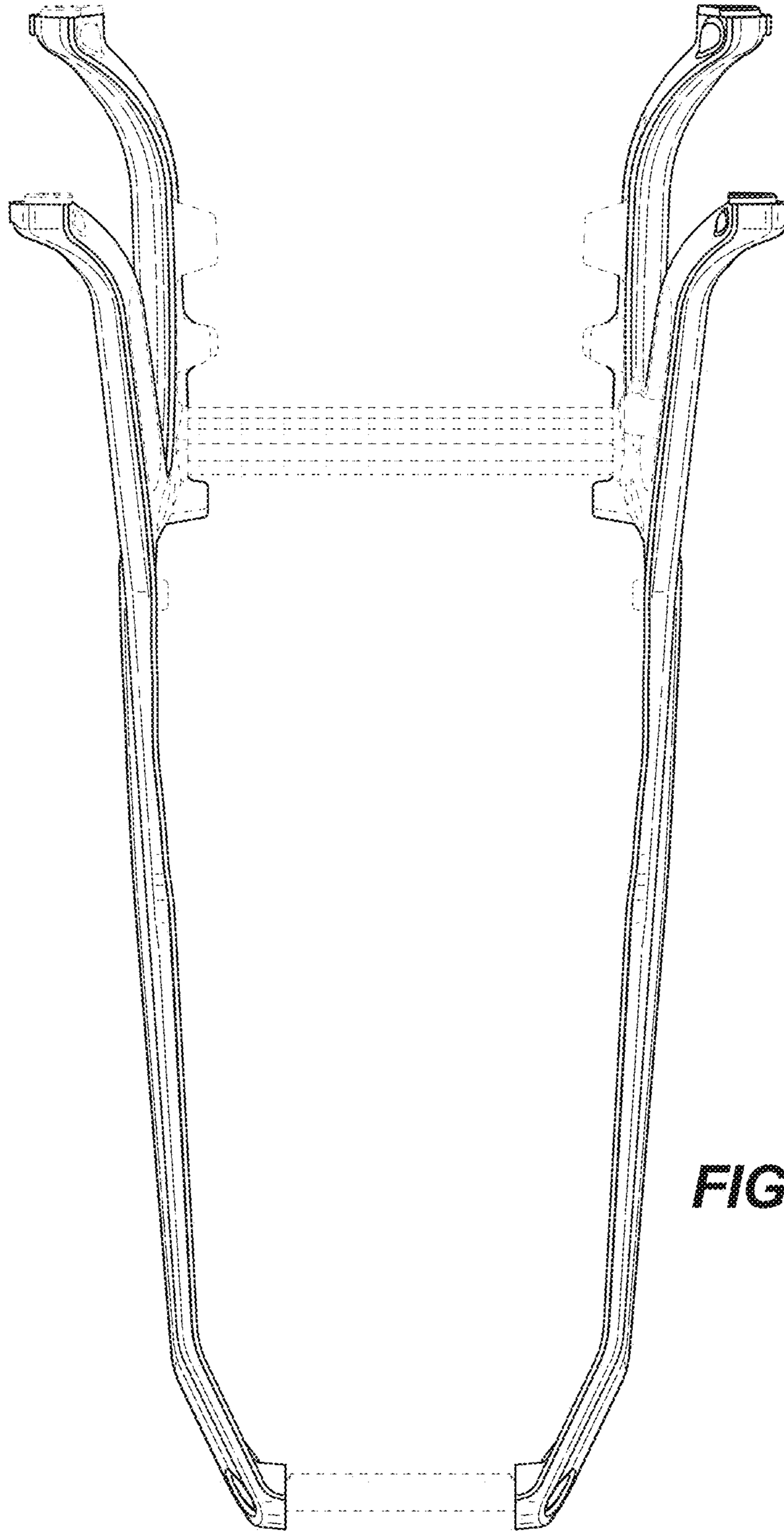

FIG. 8

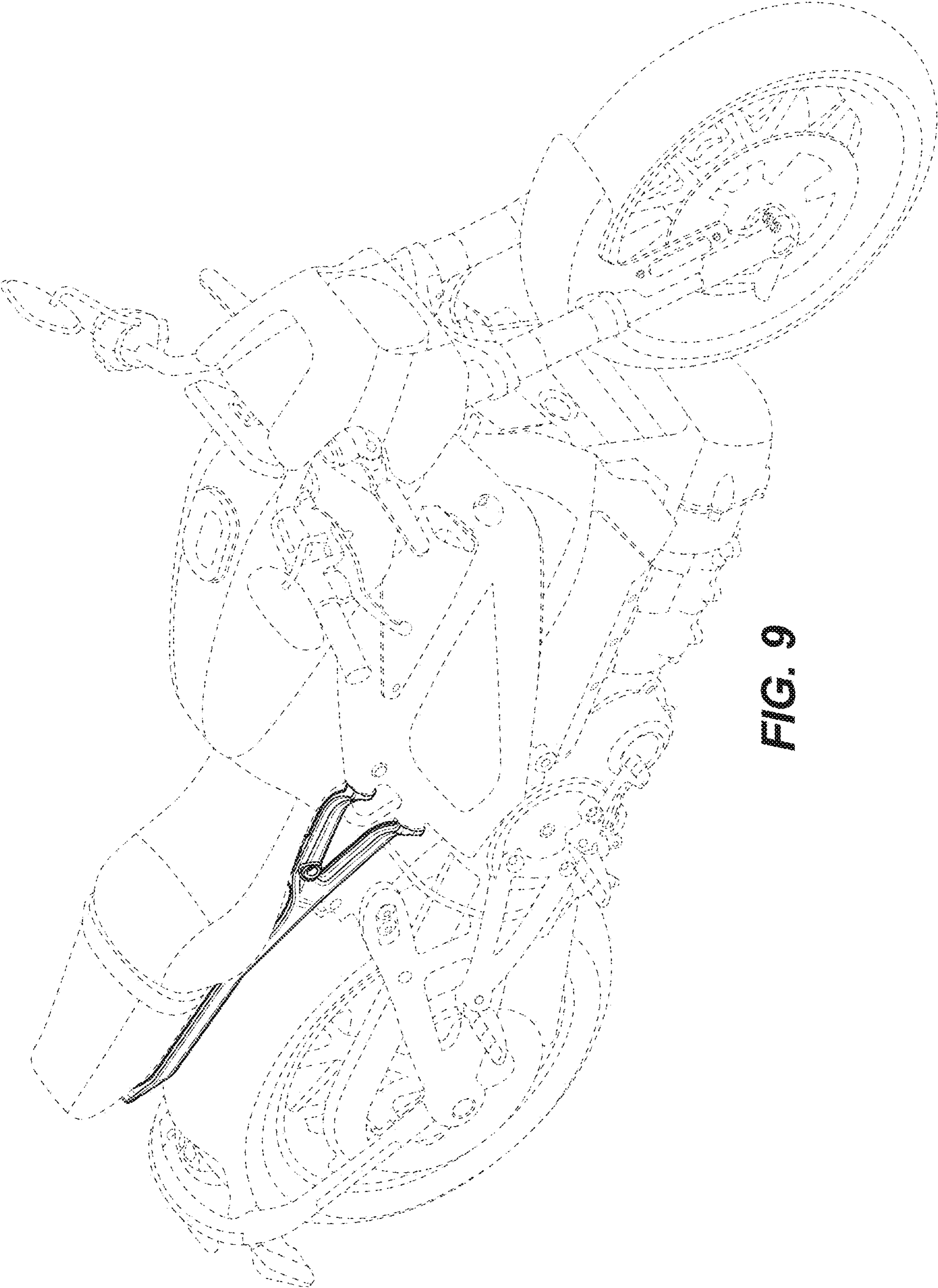

FIG. 9