



US00D881577S

(12) **United States Design Patent** (10) **Patent No.:** **US D881,577 S**
Gibson et al. (45) **Date of Patent:** **** Apr. 21, 2020**

(54) **CARRYING CASE**
(71) Applicants: **Baxalta GmbH**, Glattpark (Opfikon) (CH); **Baxalta Incorporated**, Bannockburn, IL (US)
(72) Inventors: **Madeleine Clare Gibson**, Madison, WI (US); **Seth Dale Jones**, Round Lake, IL (US); **Daniel Edward Roush**, Niles, IL (US); **Nicholas John Schill**, Johnsburg, IL (US); **Ron Theis**, Kewaskum, WI (US); **Denise A. Alexander**, Naperville, IL (US)

6,068,402 A 5/2000 Freese et al.
6,193,034 B1 2/2001 Fournier
6,390,260 B1 5/2002 Roegner
6,907,989 B2 6/2005 Ho
6,994,132 B2 2/2006 Antrobus
D550,459 S 9/2007 Eskandry
7,597,209 B2 10/2009 Rothschild et al.
D610,466 S 2/2010 Kale et al.
7,845,508 B2 12/2010 Rothschild et al.
7,950,509 B2 5/2011 Redzisz
8,167,157 B2 5/2012 Shalomoff
8,714,389 B2 5/2014 Rothschild et al.
8,807,412 B2 8/2014 Thomas et al.

(Continued)

(73) Assignees: **Baxalta GmbH**, Glattpark (Opfikon) (CH); **Baxalta Incorporated**, Bannockburn, IL (US)

(**) Term: **15 Years**

(21) Appl. No.: **29/665,385**

(22) Filed: **Oct. 3, 2018**

(51) **LOC (12) Cl.** **03-01**

(52) **U.S. Cl.**
USPC **D3/318**

(58) **Field of Classification Search**
USPC D3/232, 245-246, 318
CPC A45C 1/024; A45C 3/06
See application file for complete search history.

(56) **References Cited**

U.S. PATENT DOCUMENTS

2,254,578 A 9/1941 O'Brien
3,173,465 A 3/1965 Pastini
4,561,525 A 12/1985 Shidner
5,052,555 A 10/1991 Harmon
5,207,303 A 5/1993 Oswald et al.
5,337,933 A 8/1994 Nunez
5,592,691 A 1/1997 Ronald

FOREIGN PATENT DOCUMENTS

CN 2875362 Y 3/2007
EP 0 649 613 A1 4/1995

(Continued)

Primary Examiner — Holly H Baynham

(74) *Attorney, Agent, or Firm* — Wolf, Greenfield & Sacks, P.C.

(57) **CLAIM**

The ornamental design for a carrying case, as shown and described.

DESCRIPTION

FIG. 1 is a top, front, right side perspective view of a carrying case;
FIG. 2 is a front elevation view thereof;
FIG. 3 is a rear elevation view thereof;
FIG. 4 is a left side elevation view thereof;
FIG. 5 is a right side elevation view thereof;
FIG. 6 is a top plan view thereof; and,
FIG. 7 is a bottom plan view thereof.

The long dash-short dash lines represent the bounds of the claimed design. The dashed lines shown illustrate portions of the carrying case that form no part of the claimed design.

1 Claim, 5 Drawing Sheets



(56)

References Cited

U.S. PATENT DOCUMENTS

9,480,317 B2 11/2016 Rothschild et al.
D819,967 S * 6/2018 Carter D3/246
D824,666 S * 8/2018 Carter D3/245
D831,348 S * 10/2018 Wells D3/245
D868,390 S 11/2019 Santo Domingo
2008/0245096 A1 10/2008 Hanson et al.
2010/0008601 A1 1/2010 Prudencio
2010/0181220 A1 7/2010 Dasara
2017/0020251 A1 1/2017 Rothschild et al.
2017/0320509 A1 11/2017 Ryan
2018/0014614 A1 1/2018 Marshall

FOREIGN PATENT DOCUMENTS

FR 2 580 910 A 10/1986
JP 3015675 U 9/1995
WO WO 2015/197200 A1 12/2015

* cited by examiner

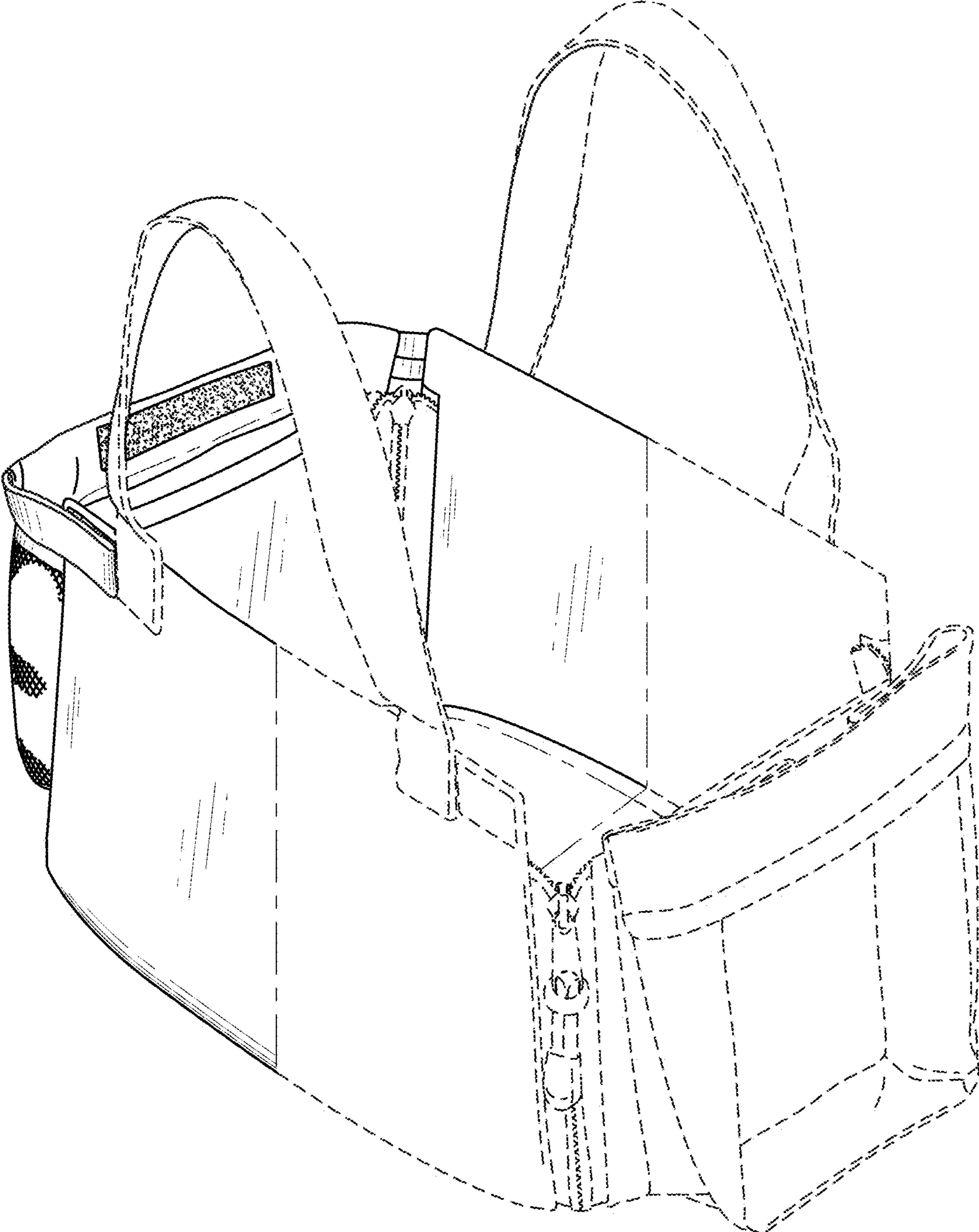

FIG. 1

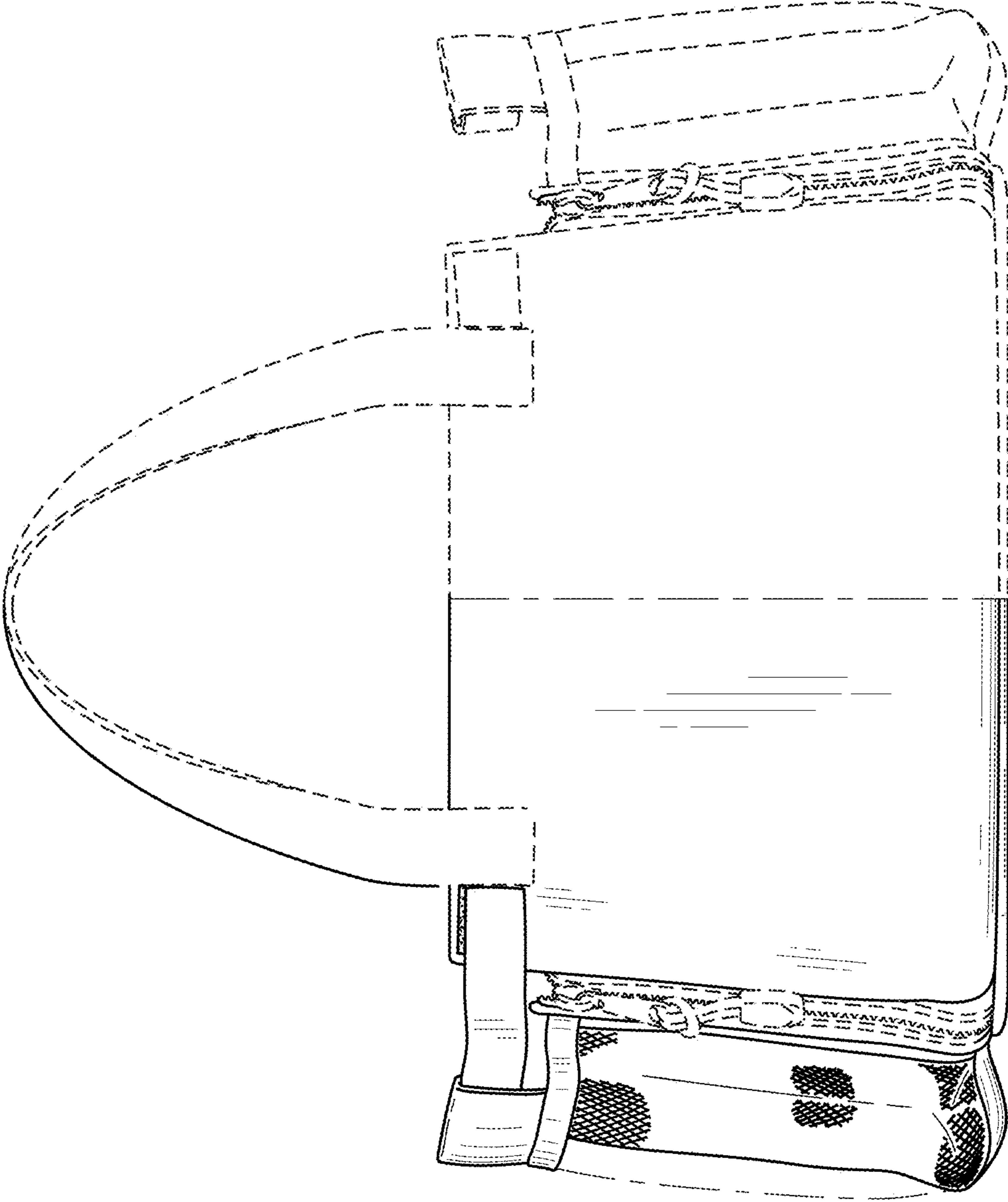

FIG. 2

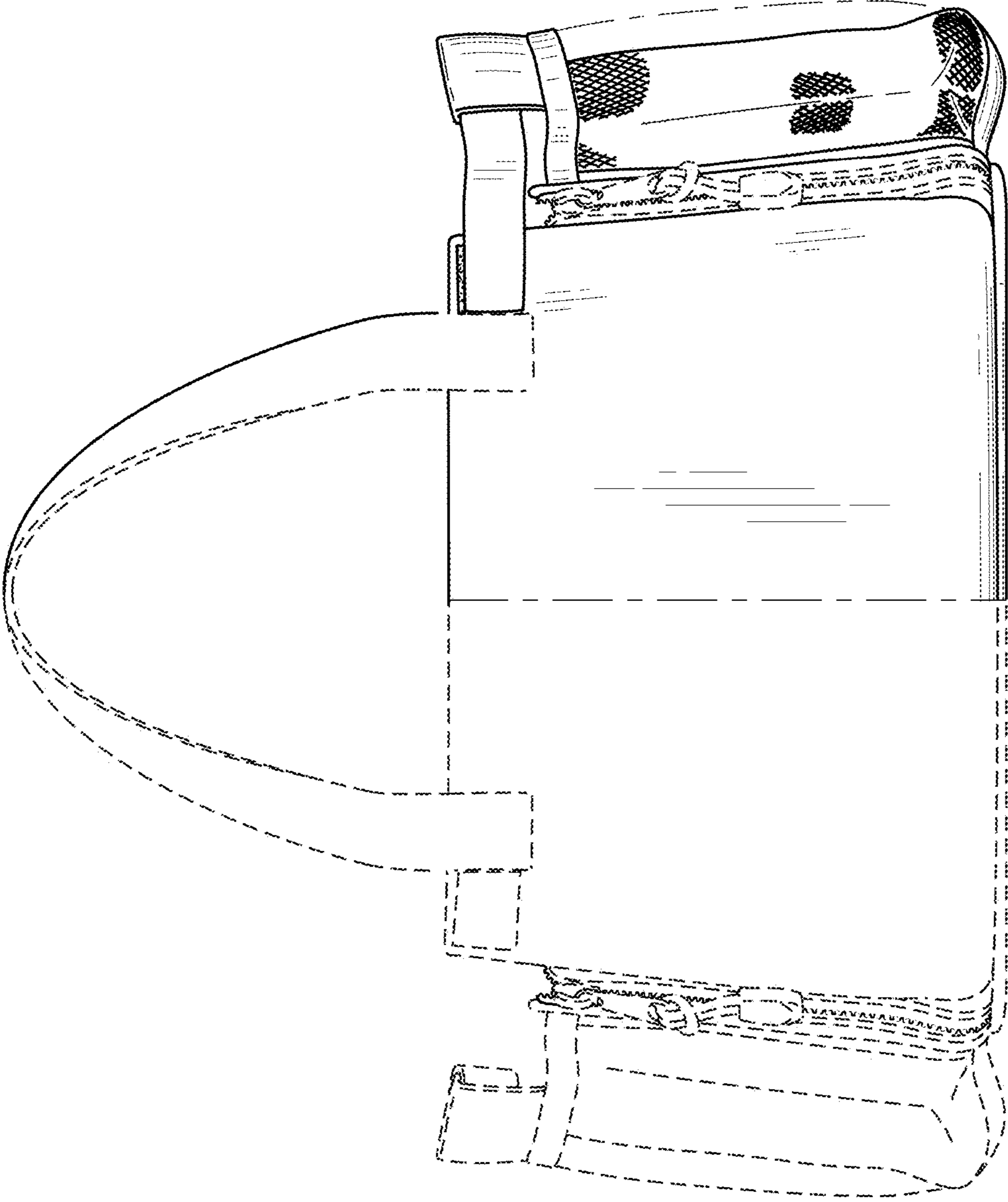

FIG. 3

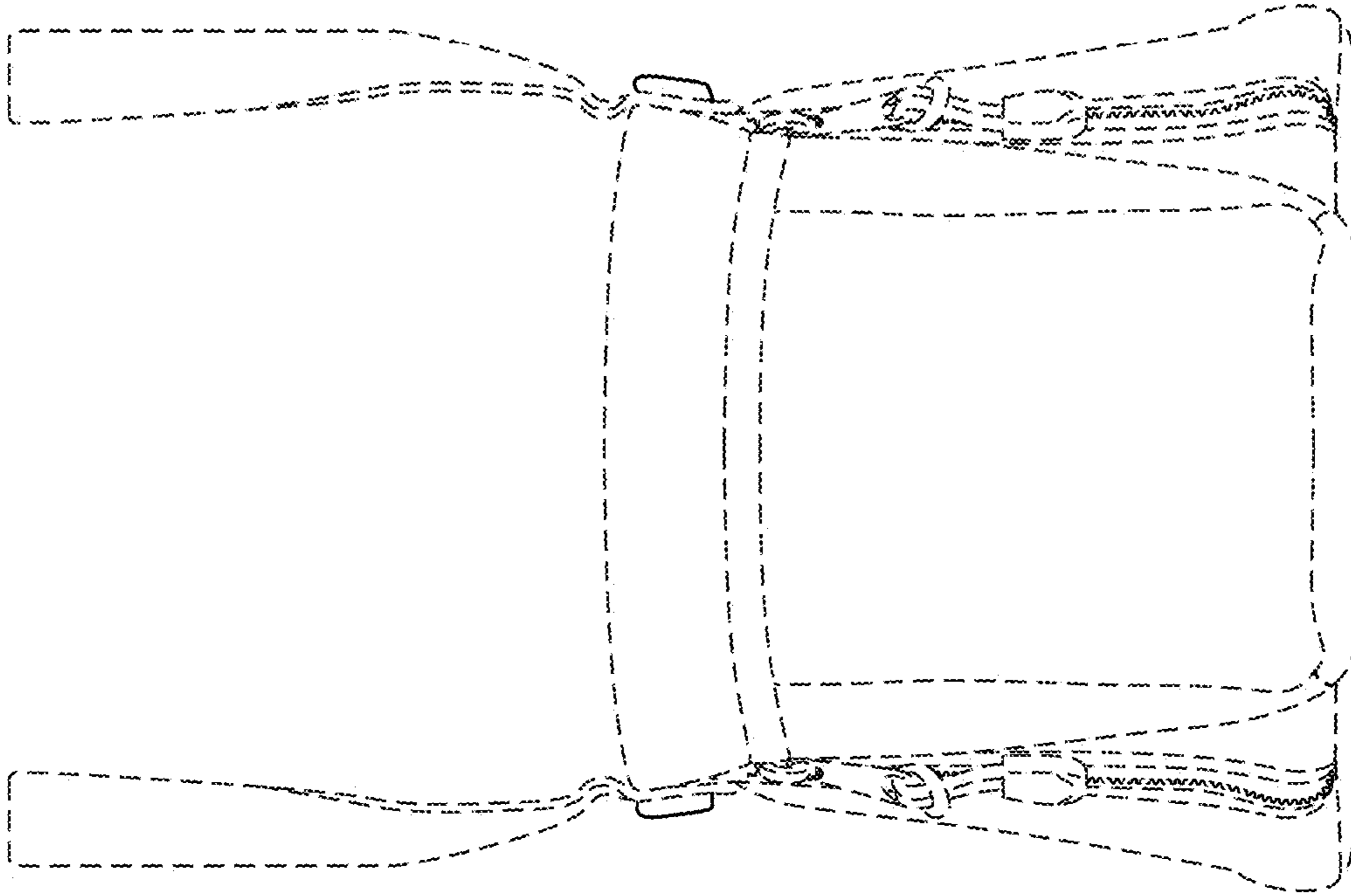

FIG. 5

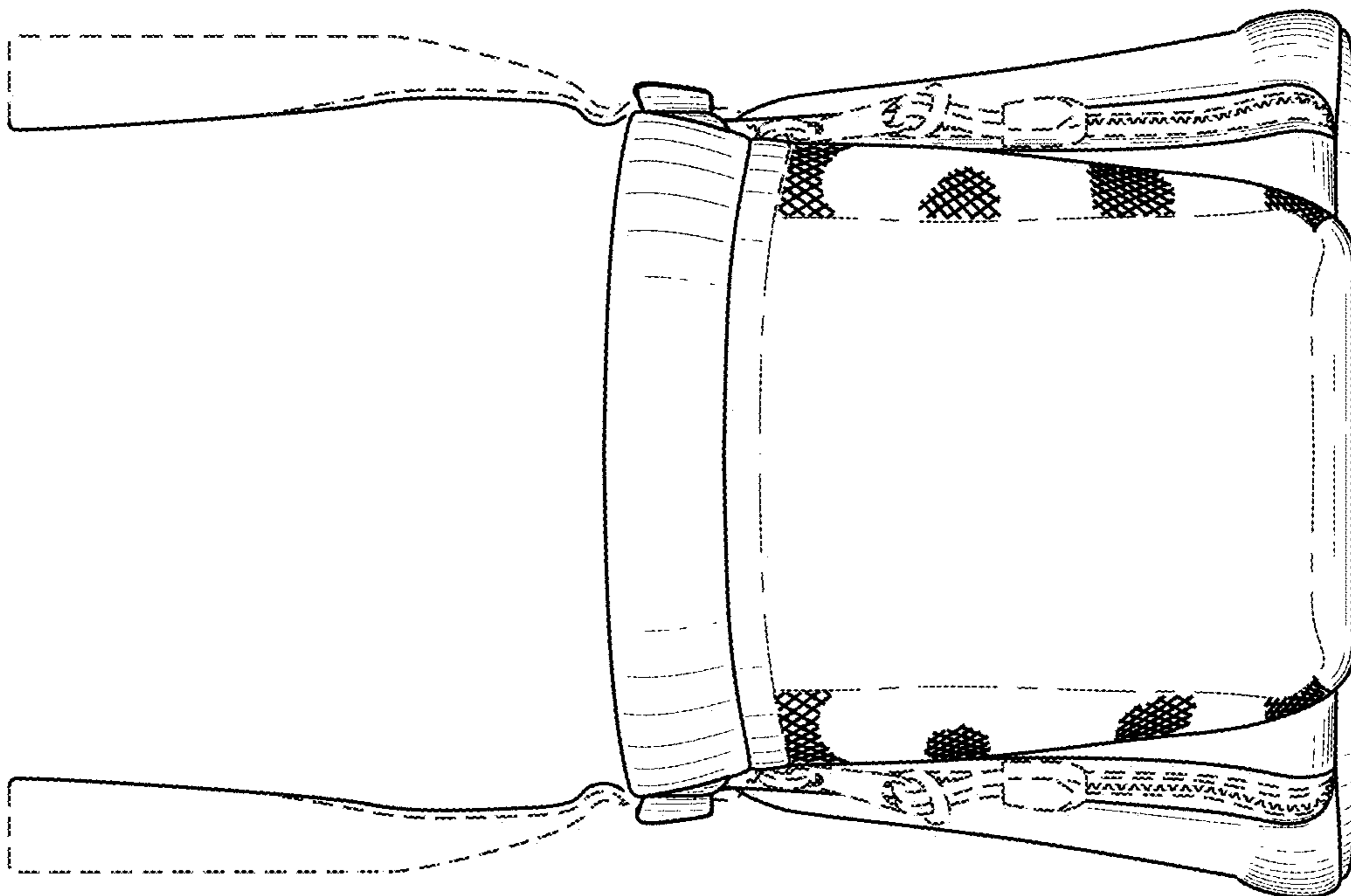

FIG. 4

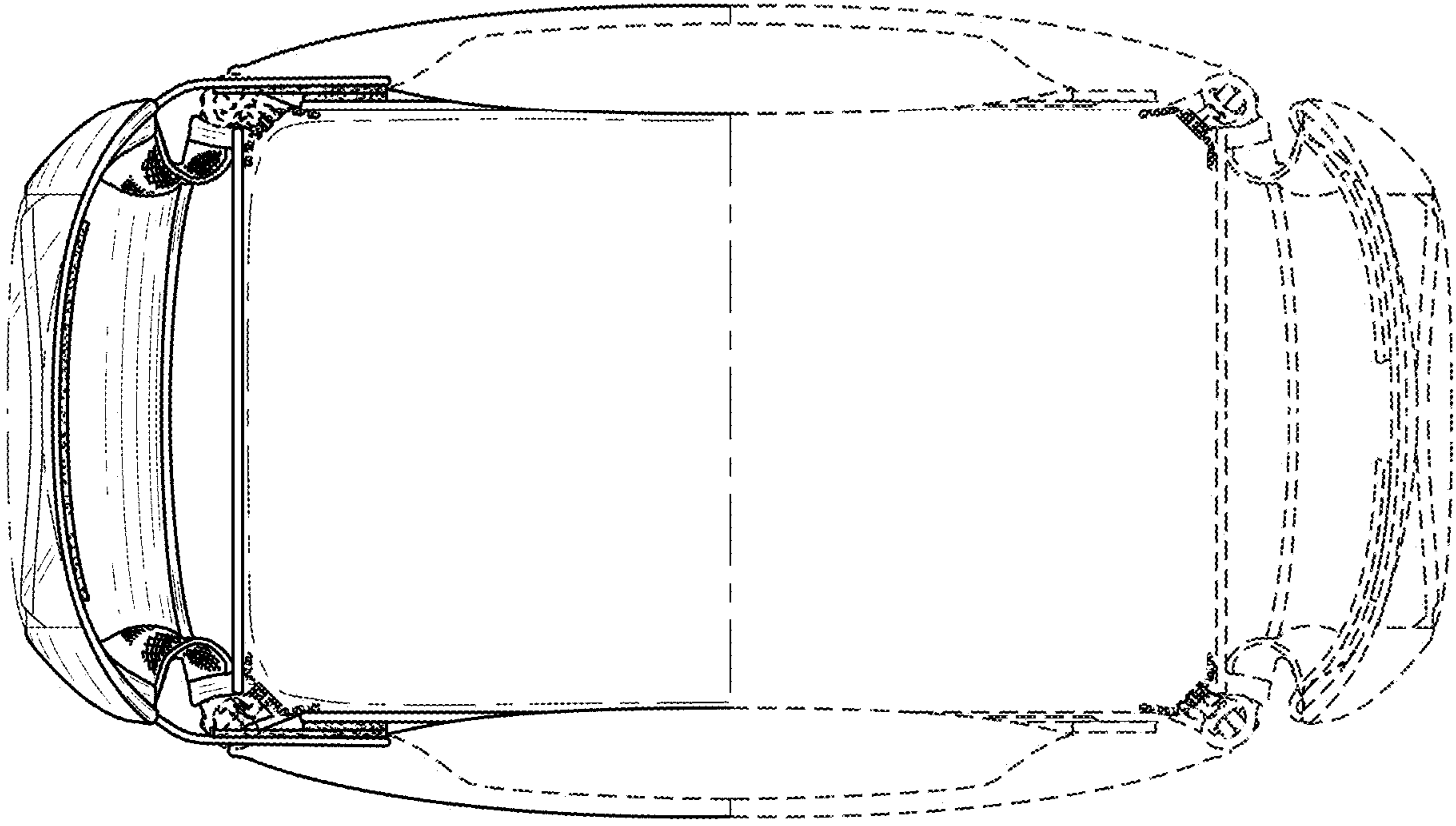

FIG. 6

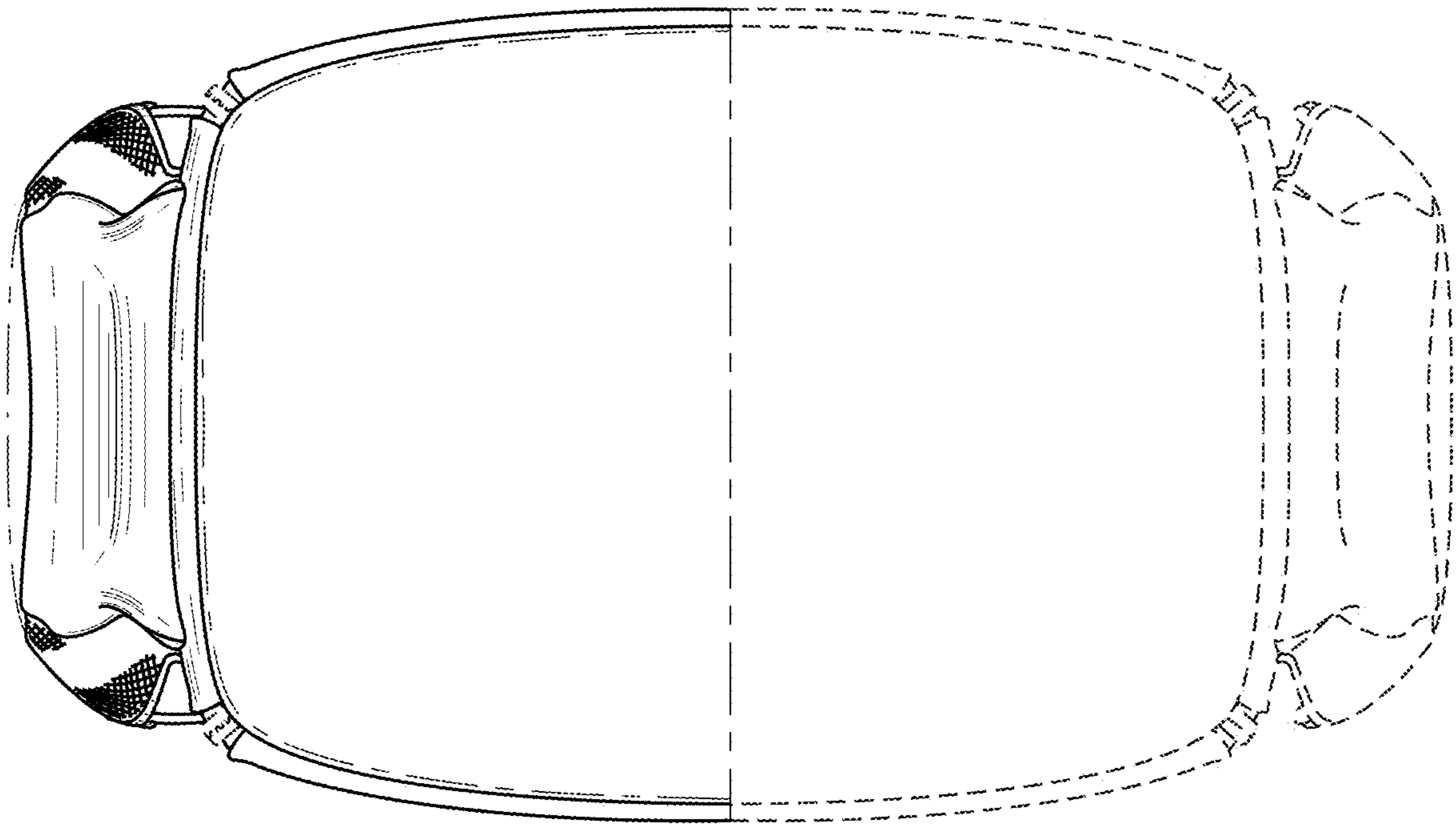

FIG. 7