



US00D880796S

(12) **United States Design Patent** (10) **Patent No.:** **US D880,796 S**
Baldwin et al. (45) **Date of Patent:** **** Apr. 7, 2020**

(54) **CLEANING ARTICLE**

(71) Applicant: **3M INNOVATIVE PROPERTIES COMPANY**, St. Paul, MN (US)

(72) Inventors: **Mark W. Baldwin**, Woodbury, MN (US); **Matthew D. Chaffee**, Minneapolis, MN (US); **Paul N. Daveloose**, Maplewood, MN (US)

(73) Assignee: **3M INNOVATIVE PROPERTIES COMPANY**, St. Paul, MN (US)

(**) Term: **15 Years**

(21) Appl. No.: **29/663,088**

(22) Filed: **Sep. 12, 2018**

(51) **LOC (12) Cl.** **07-05**

(52) **U.S. Cl.**
USPC **D32/40**

(58) **Field of Classification Search**
USPC D32/40-43, 50-52; D21/471, 473, 499; D28/59; D5/4, 7, 25, 53, 57-58
(Continued)

(56) **References Cited**

U.S. PATENT DOCUMENTS

D58,840 S * 8/1921 Thompson D5/59
D125,036 S * 2/1941 Galper D5/53
(Continued)

FOREIGN PATENT DOCUMENTS

CA 135400 4/2011
JP D1577027 * 5/2017

OTHER PUBLICATIONS

Scotch-Brite (18 Pack) 3M Dishwand Refill, Ylive store reviews 2018, http://www.yliverstore.com/index.php?main_page=product_info&cPath=&products_id=1 . . . site visited Oct. 28, 2019 (Year: 2019).*

(Continued)

Primary Examiner — Lilyana Bekic
Assistant Examiner — John R Yeh

(74) *Attorney, Agent, or Firm* — 3M Innovative Properties Compa

(57) **CLAIM**

The ornamental design for a cleaning article, as shown and described.

DESCRIPTION

FIG. 1 is a perspective view showing the new design for a cleaning article;
FIG. 2 is a front view thereof;
FIG. 3 is a rear view thereof;
FIG. 4 is a top view thereof;
FIG. 5 is a bottom view thereof;
FIG. 6 is a left side view thereof;
FIG. 7 is a right side view thereof;
FIG. 8 is a perspective view of a second embodiment showing the new design for a cleaning article;
FIG. 9 is a front view thereof;
FIG. 10 is a rear view thereof;
FIG. 11 is a top view thereof;
FIG. 12 is a bottom view thereof;
FIG. 13 is a left side view thereof;
FIG. 14 is a right side view thereof;
FIG. 15 is a perspective view of a third embodiment showing the new design for a cleaning article;
FIG. 16 is a front view thereof;
FIG. 17 is a rear view thereof;
FIG. 18 is a top view thereof;
FIG. 19 is a bottom view thereof;
FIG. 20 is a left side view thereof;
FIG. 21 is a right side view thereof;
FIG. 22 is a perspective view of a fourth embodiment showing the new design for a cleaning article;
FIG. 23 is a front view thereof;
FIG. 24 is a rear view thereof;
FIG. 25 is a top view thereof;
FIG. 26 is a bottom view thereof;
FIG. 27 is a left side view thereof; and,
FIG. 28 is a right side view thereof.

(Continued)

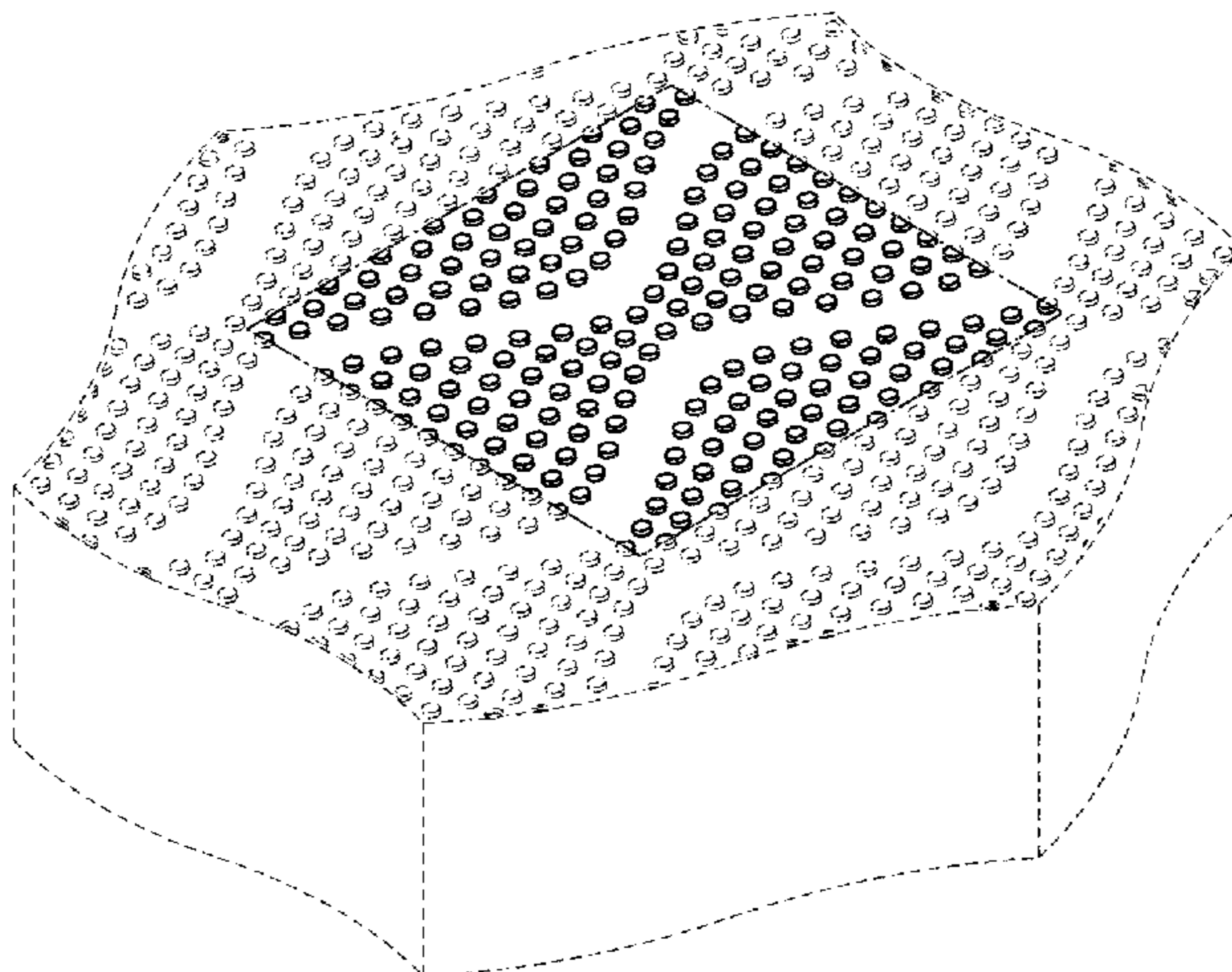

The portions of the cleaning article in FIGS. 1-28 shown in dash-dash broken lines form no part of the claimed design. In FIGS. 1, 2, 8, 9, 15, 16, 22, and 23 the dash-dot-dash broken lines represent boundaries of the claimed design and form no part thereof.

1 Claim, 13 Drawing Sheets

(58) Field of Classification Search

CPC A47L 13/12; A47L 13/20; A47L 13/16;
A45D 34/04

See application file for complete search history.

(56) References Cited

U.S. PATENT DOCUMENTS

D456,575	S	*	4/2002	Celia	D28/63
D508,332	S	*	8/2005	Julton	D5/53
D508,785	S	*	8/2005	Jeannot	D5/25
D527,910	S	*	9/2006	Enderby	D5/37
D610,753	S	*	2/2010	Moskowitz	D30/158
D632,497	S	*	2/2011	Vidal	D5/56
D632,498	S	*	2/2011	Vidal	D5/56

D662,327	S	*	6/2012	Espinosa	D5/56
D672,154	S		12/2012	Huss		
D690,117	S	*	9/2013	Haverfield	D5/57
D708,805	S	*	7/2014	Mehdizadeh	D32/40
D719,742	S	*	12/2014	Seitzinger	D5/56
D732,838	S	*	6/2015	Seitzinger	D5/57
D734,617	S	*	7/2015	Seitzinger	D5/57
D738,633	S	*	9/2015	Seitzinger	D5/56
D738,635	S	*	9/2015	Seitzinger	D5/57
D809,234	S	*	1/2018	Endle	D32/40
D819,983	S	*	6/2018	Barran	D5/56
D864,507	S	*	10/2019	Stoughton	D32/40
2005/0193365	A1	*	9/2005	Sahr	G06F 16/29 717/100
2008/0244844	A1	*	10/2008	Tung	A47L 13/16 15/104.001
2015/0059111	A1	*	3/2015	Gibis	A47L 13/16 15/118

OTHER PUBLICATIONS

Scotch-Brite® Scrub Dots Non-Scratch Scrub Sponge, Scotch Brite website reviews 2017, site visited Oct. 28, 2019, <https://www.scotch-brite.com/...e/tools/~/Scotch-Brite-Scrub-Dots-Non-Scratch-Scrub-Sponge/?N=4337+3290884629+3294529207&rt=rud> (Year: 2019).*

* cited by examiner

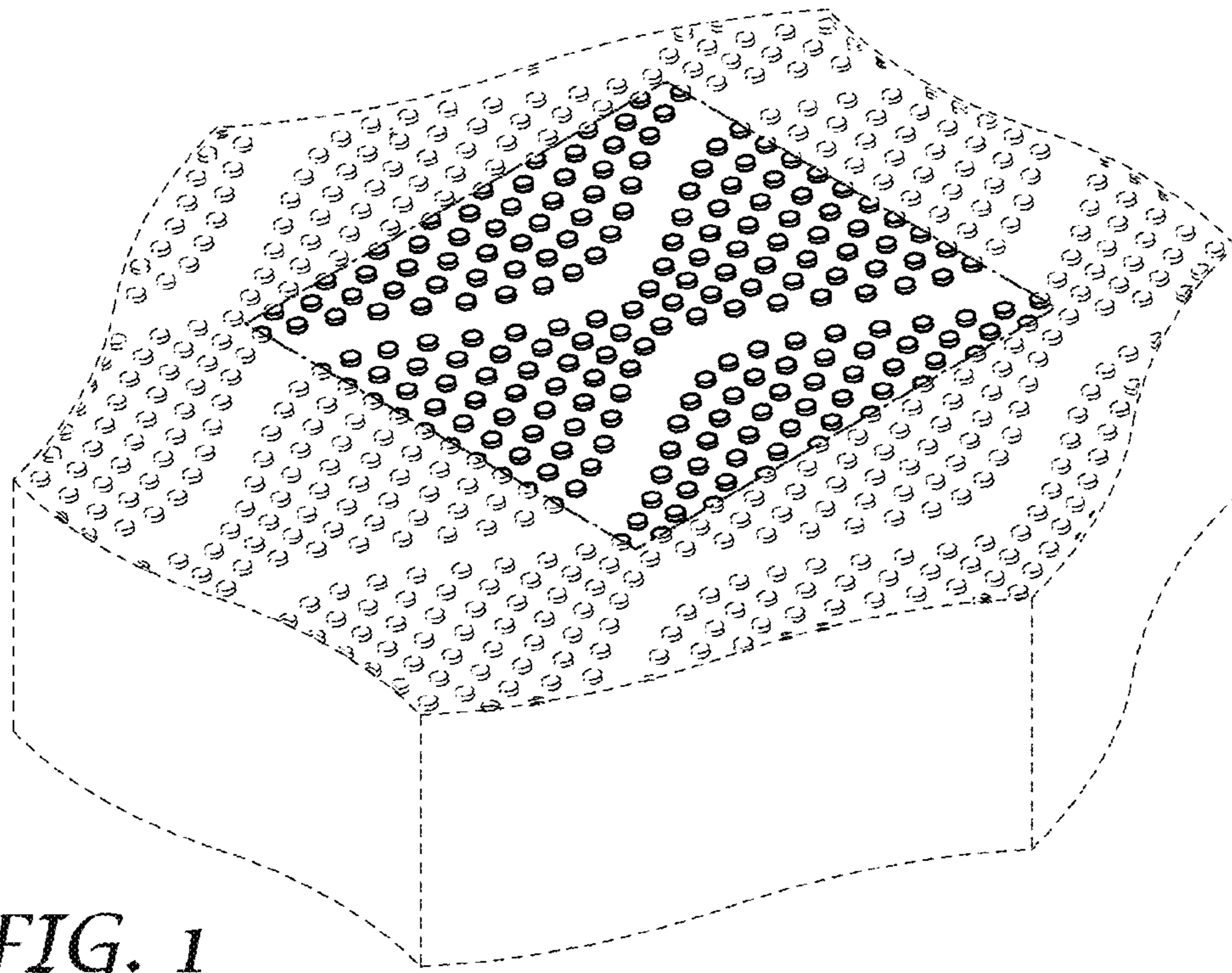

FIG. 1

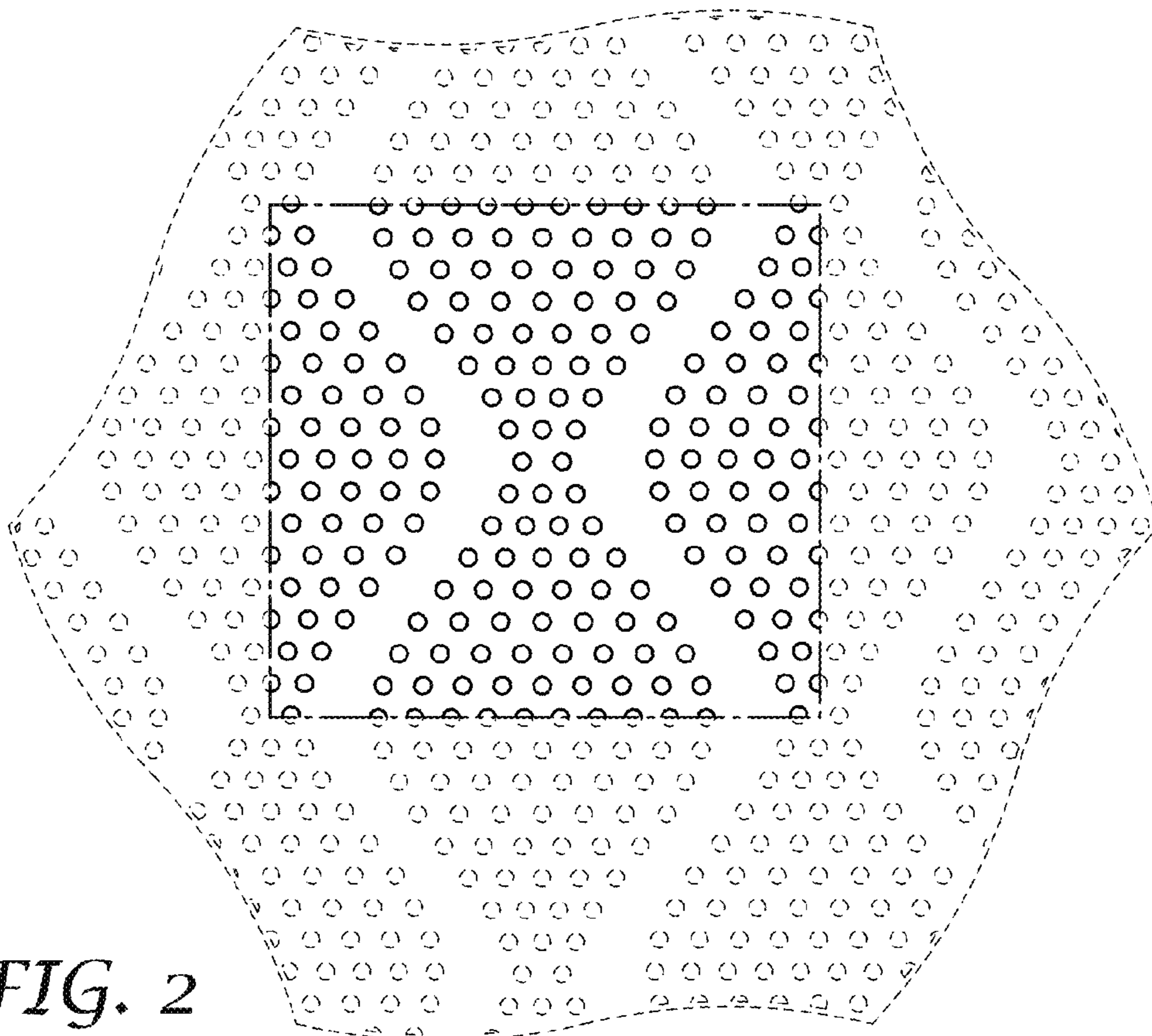
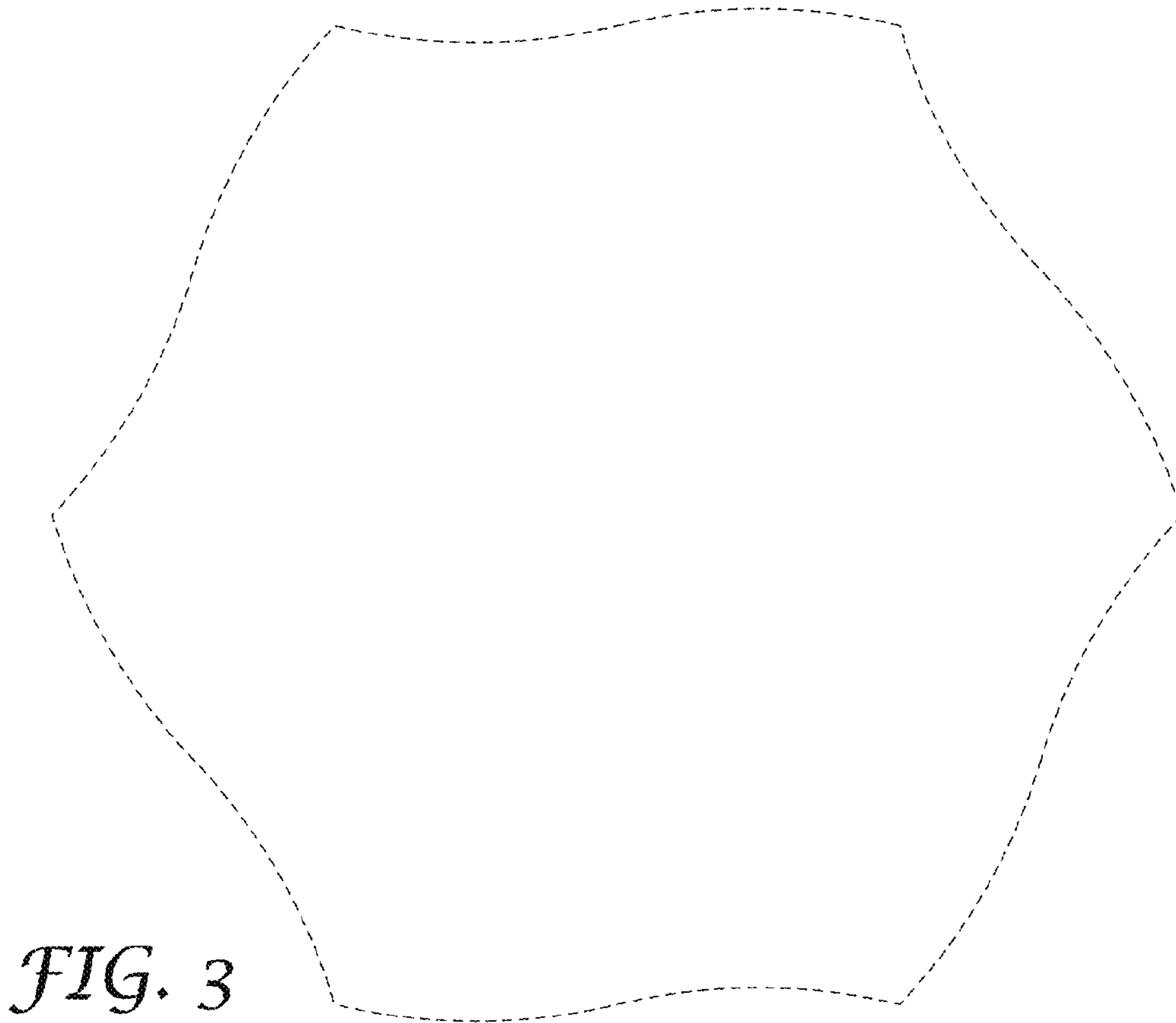

FIG. 2



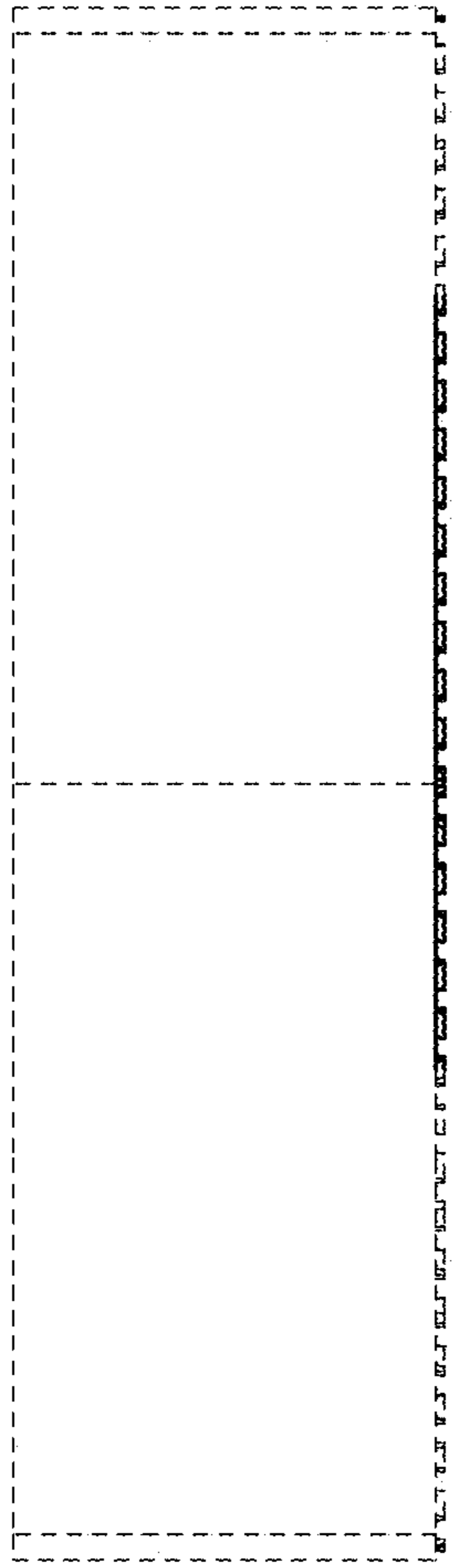

FIG. 6

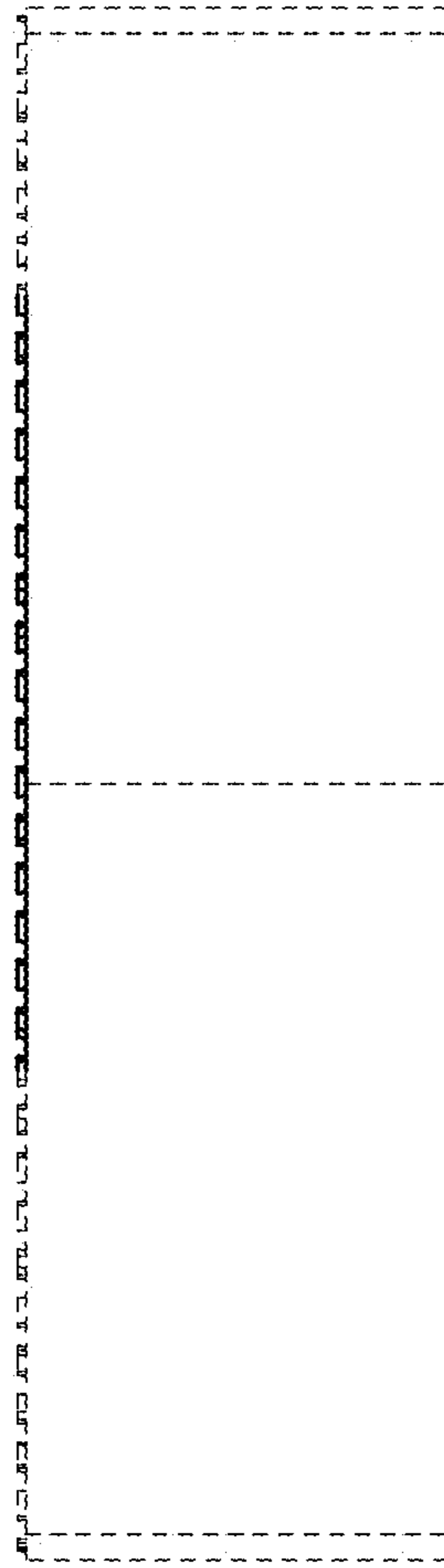

FIG. 7

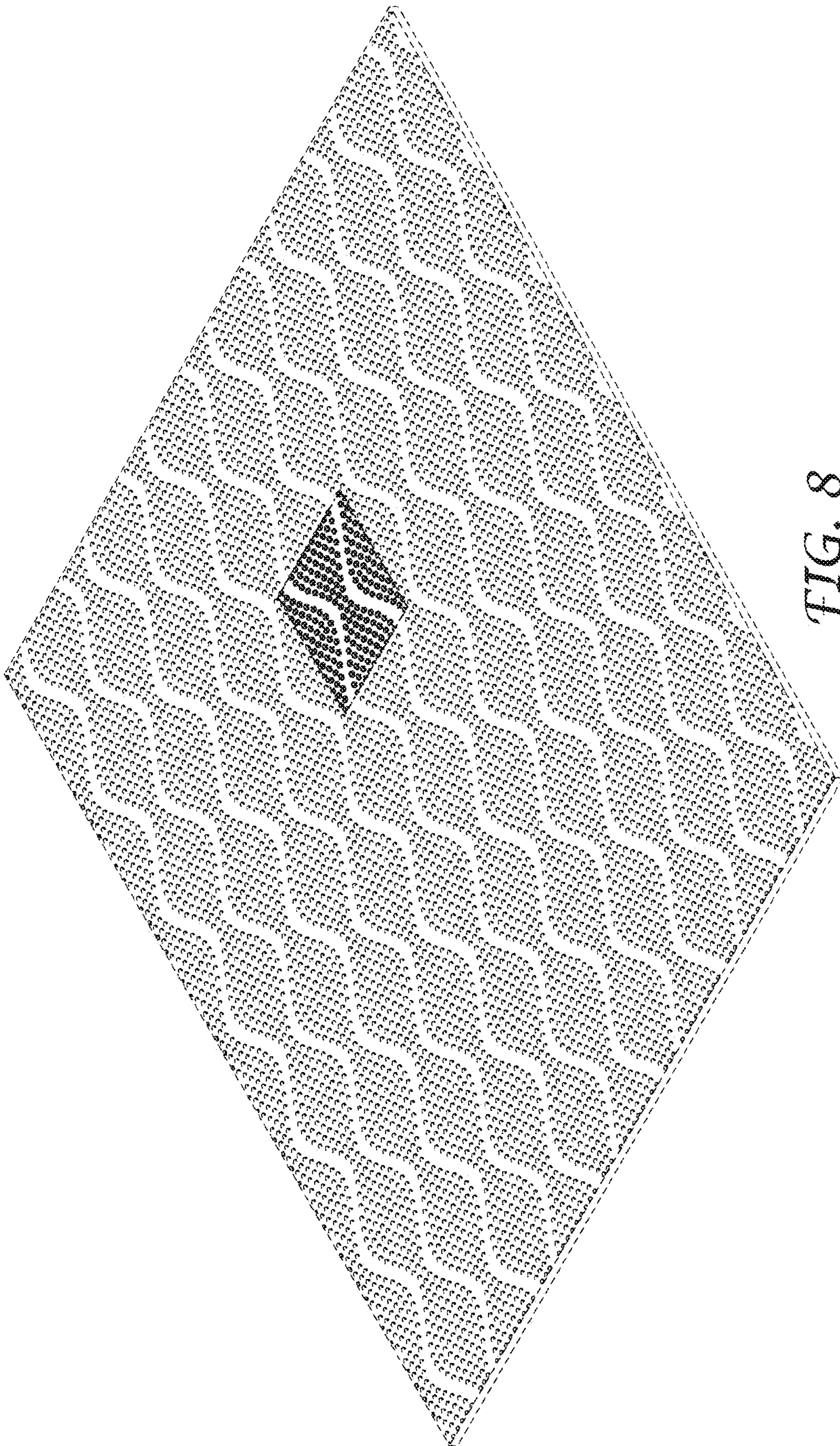

FIG. 8

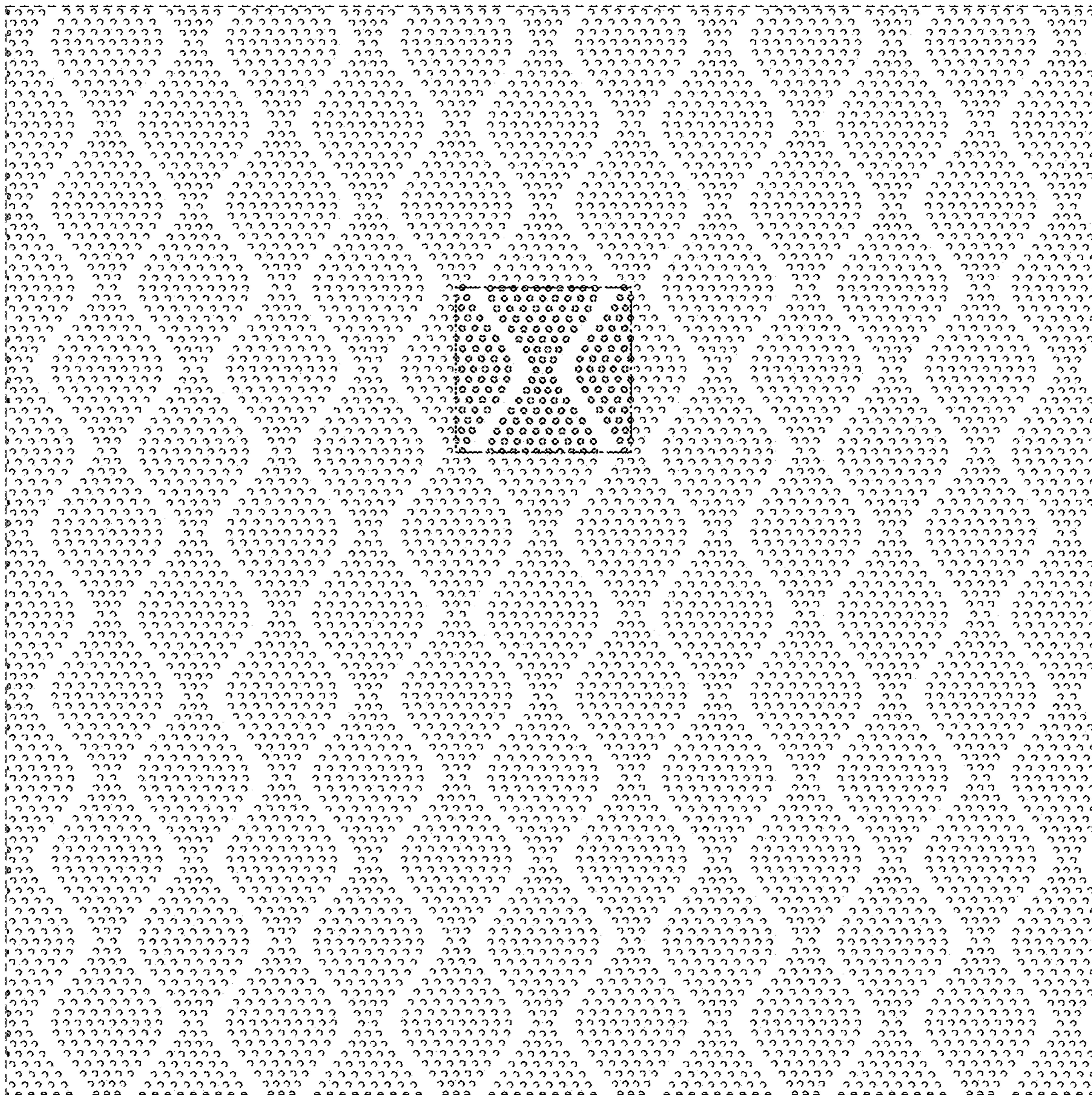

FIG. 9

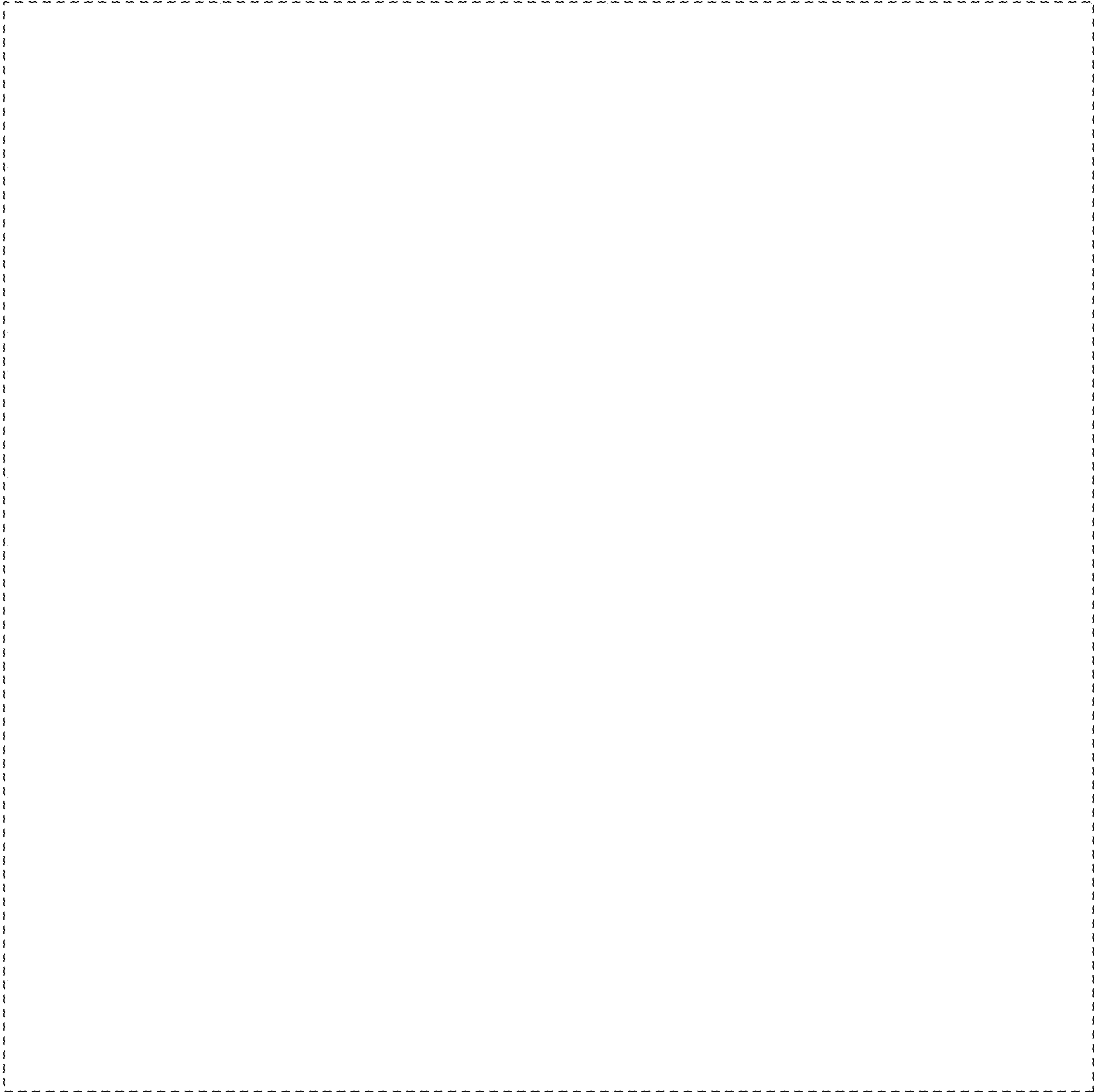

FIG. 10



FIG. 11



FIG. 12

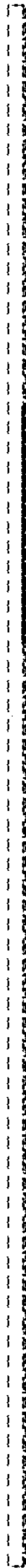

FIG. 13

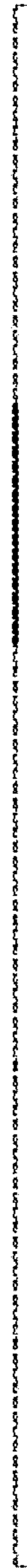

FIG. 14

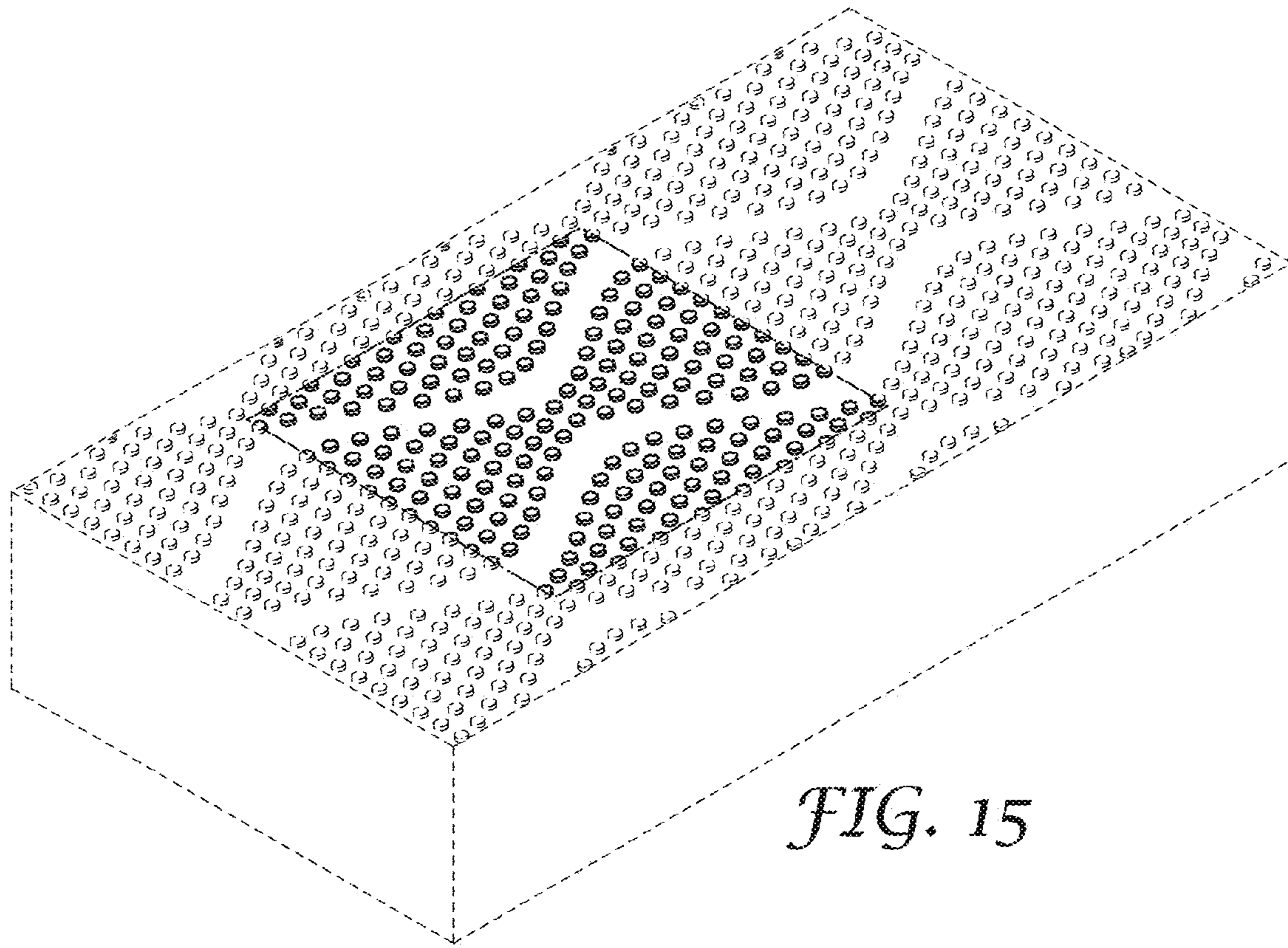

FIG. 15

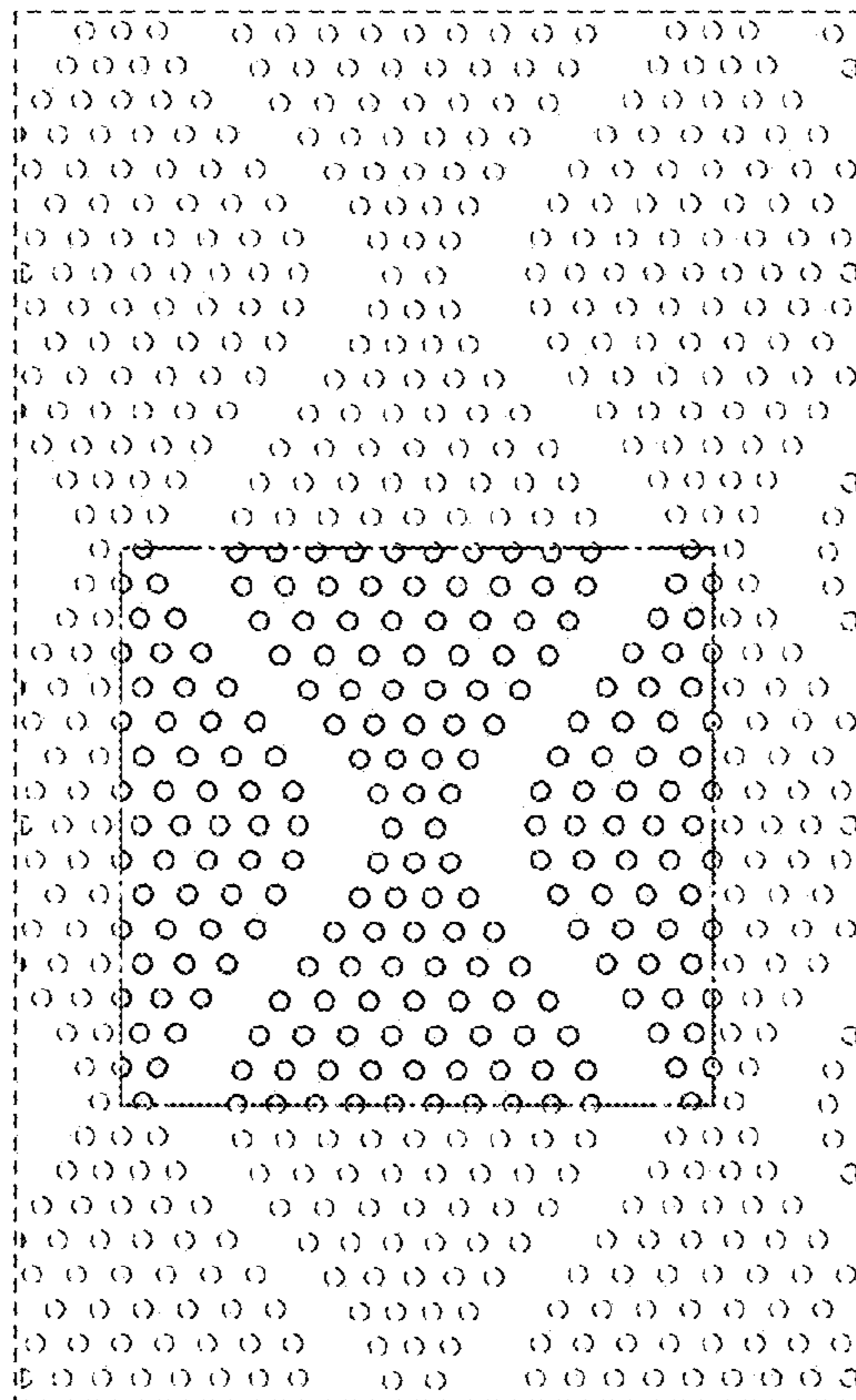

FIG. 16

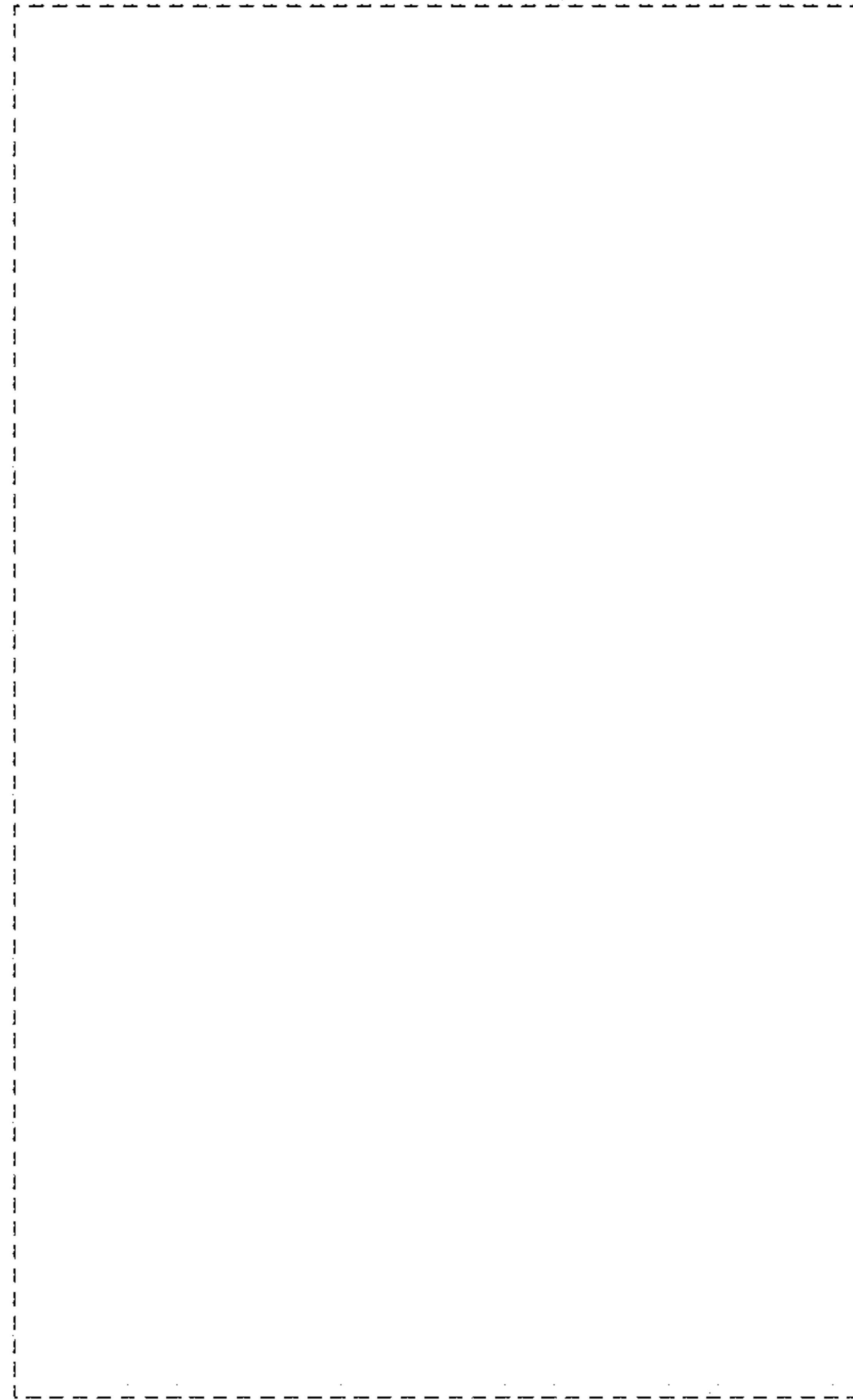

FIG. 17



FIG. 18

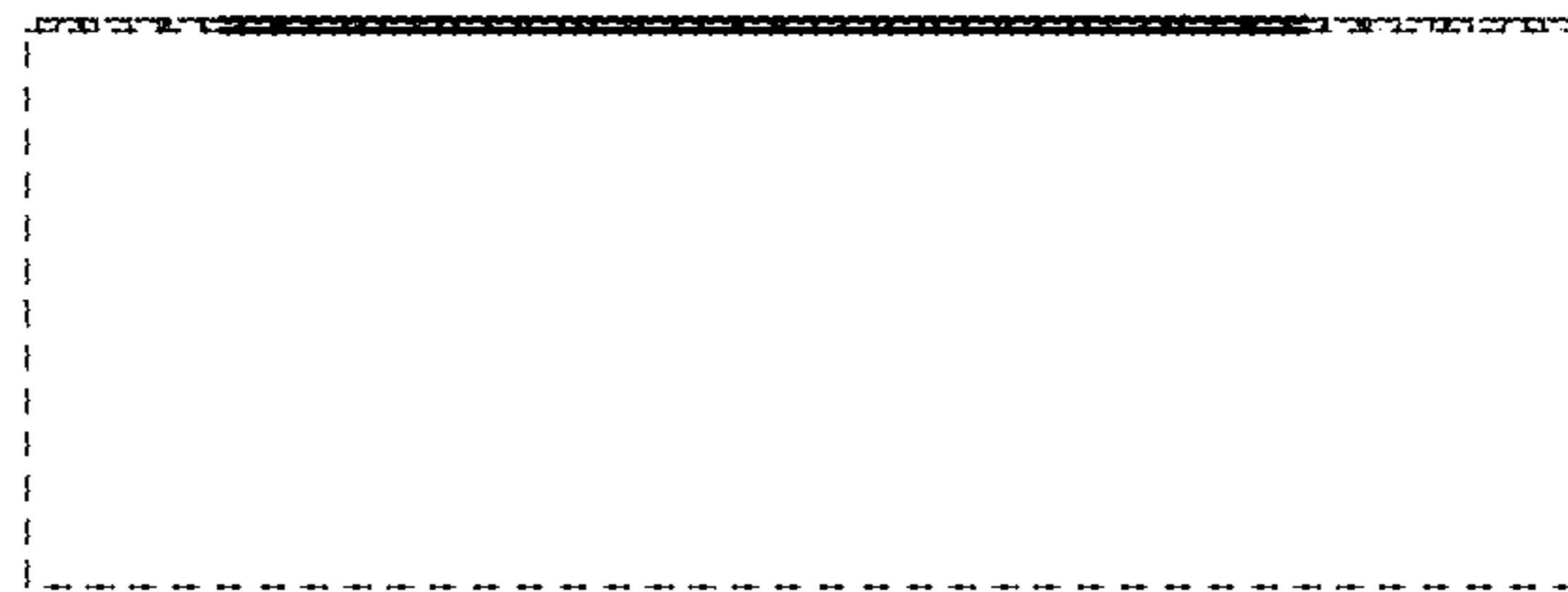

FIG. 19

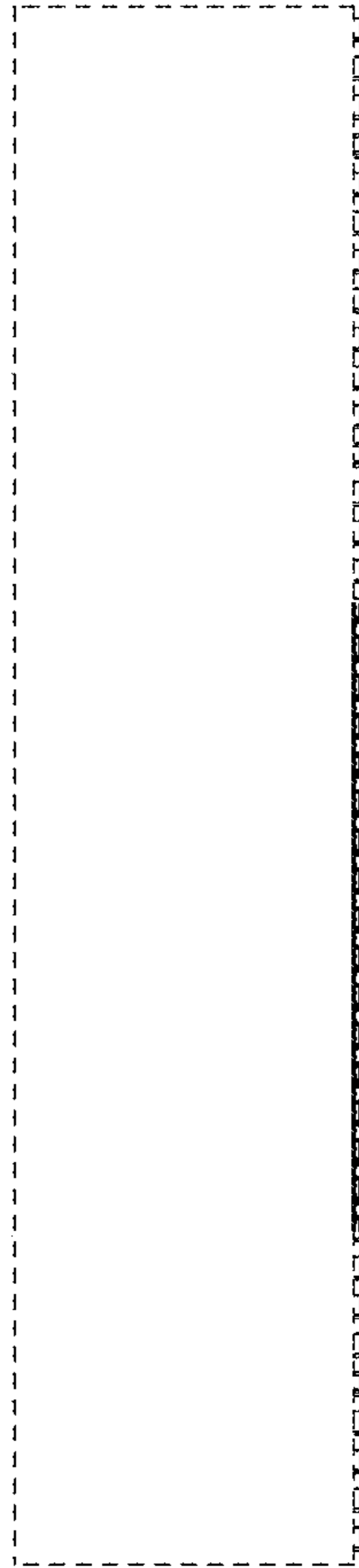

FIG. 20

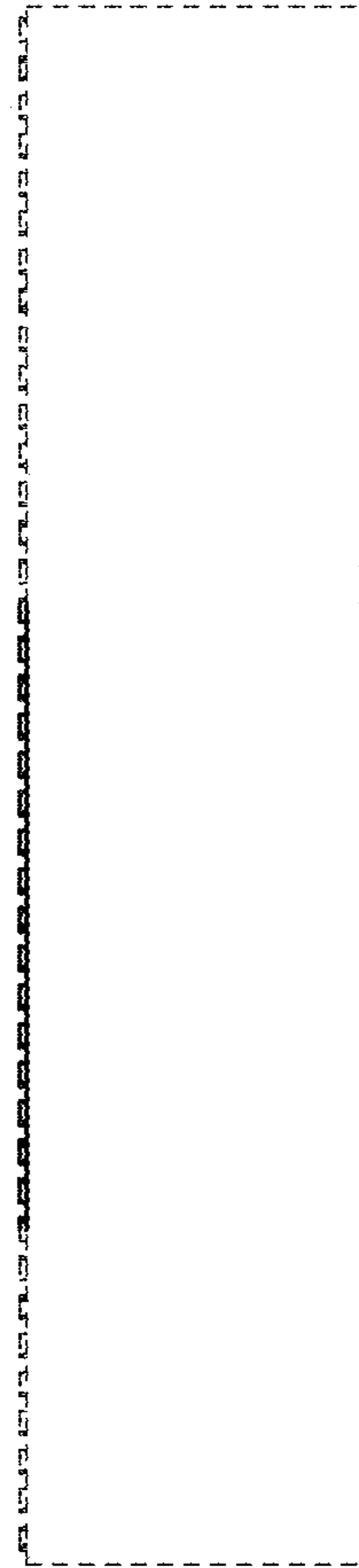

FIG. 21

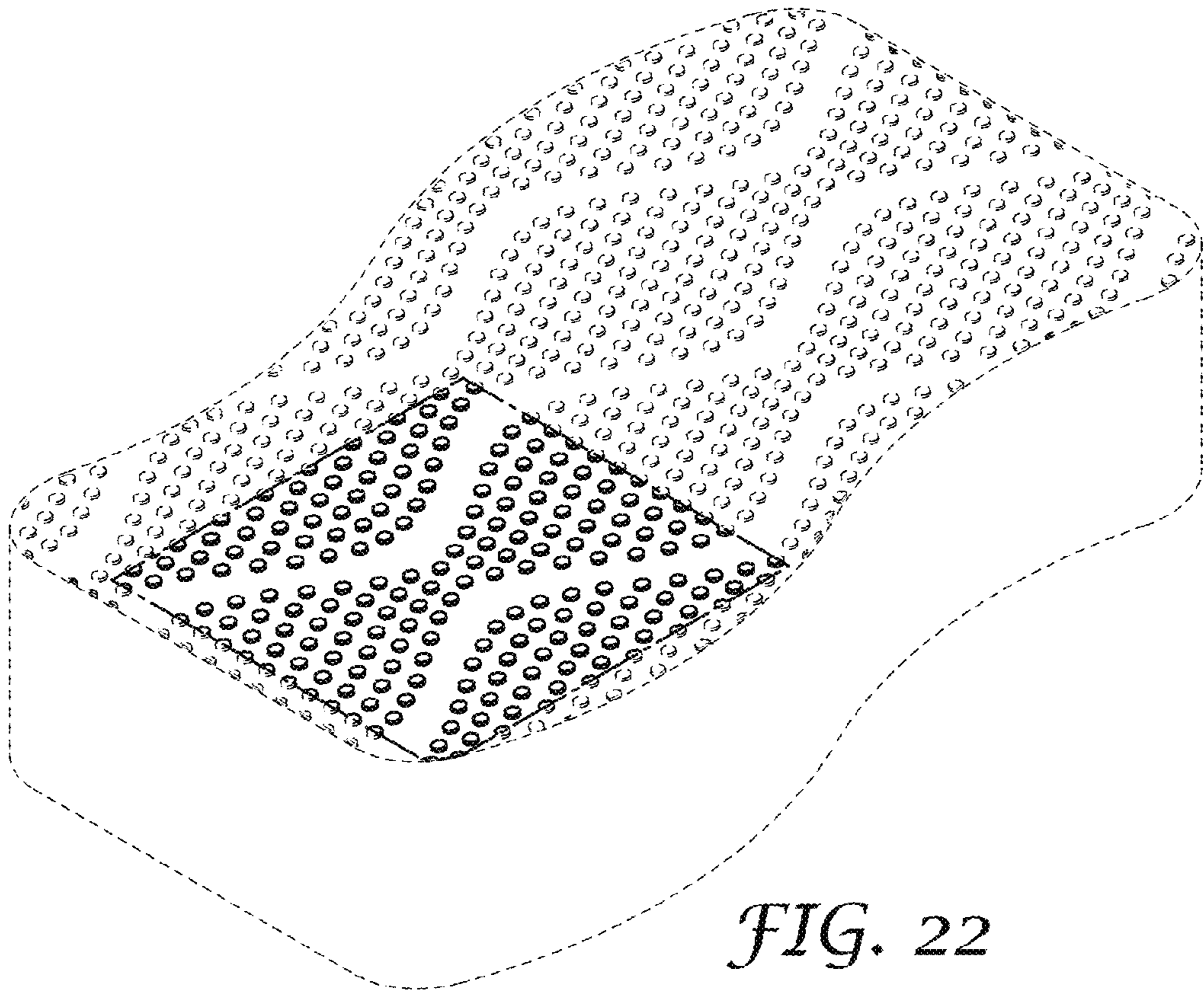

FIG. 22

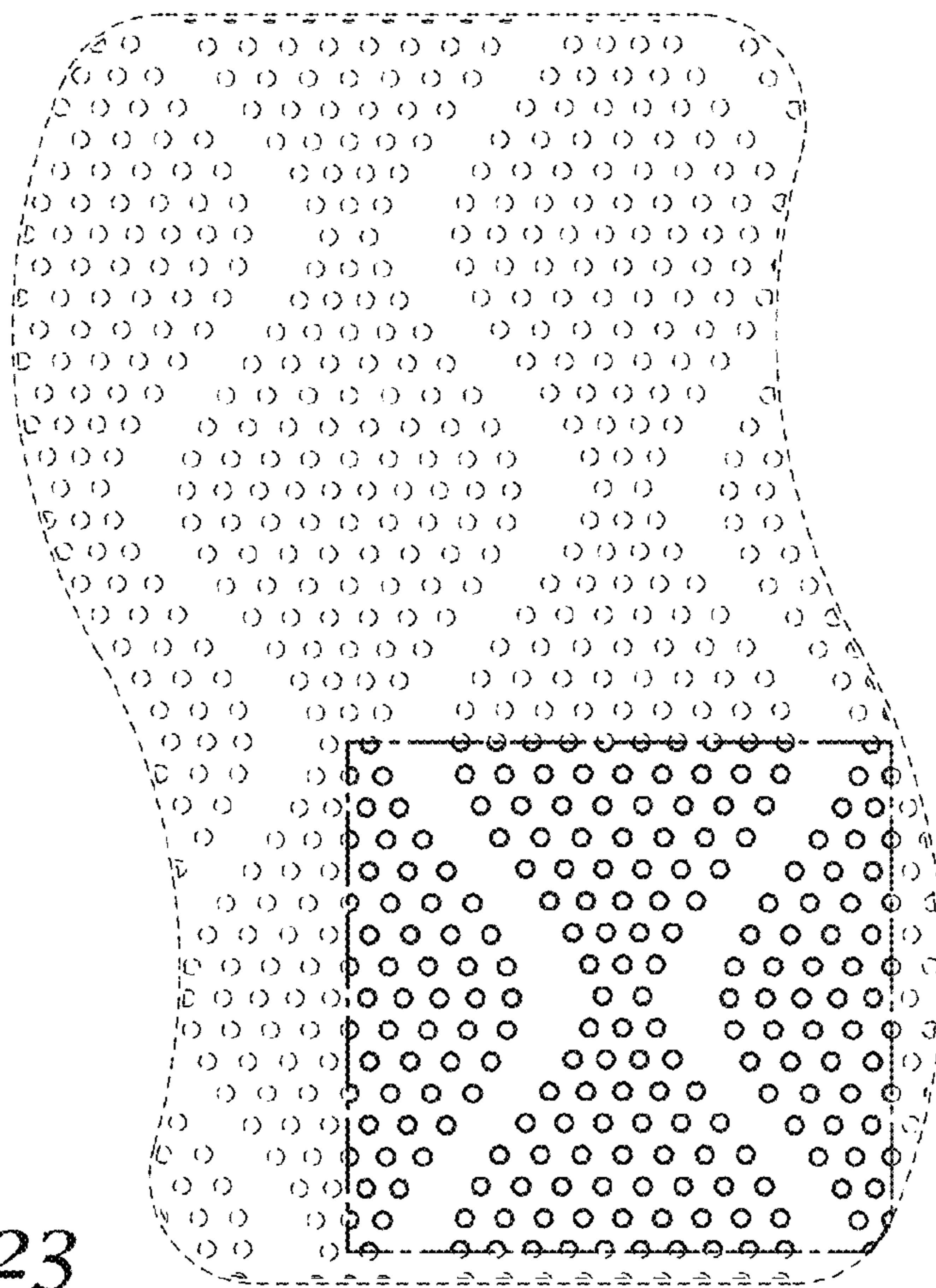

FIG. 23

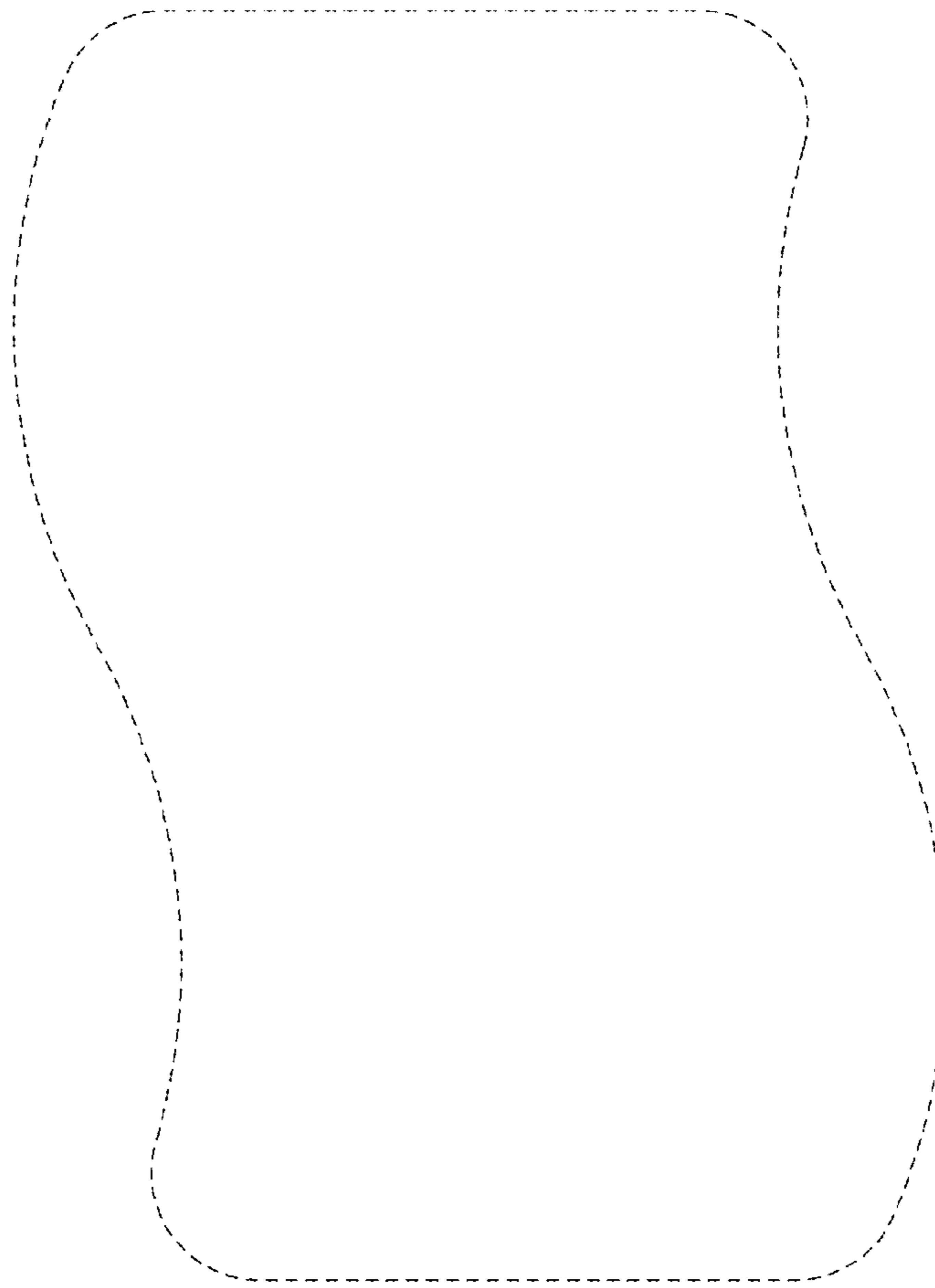

FIG. 24



FIG. 25

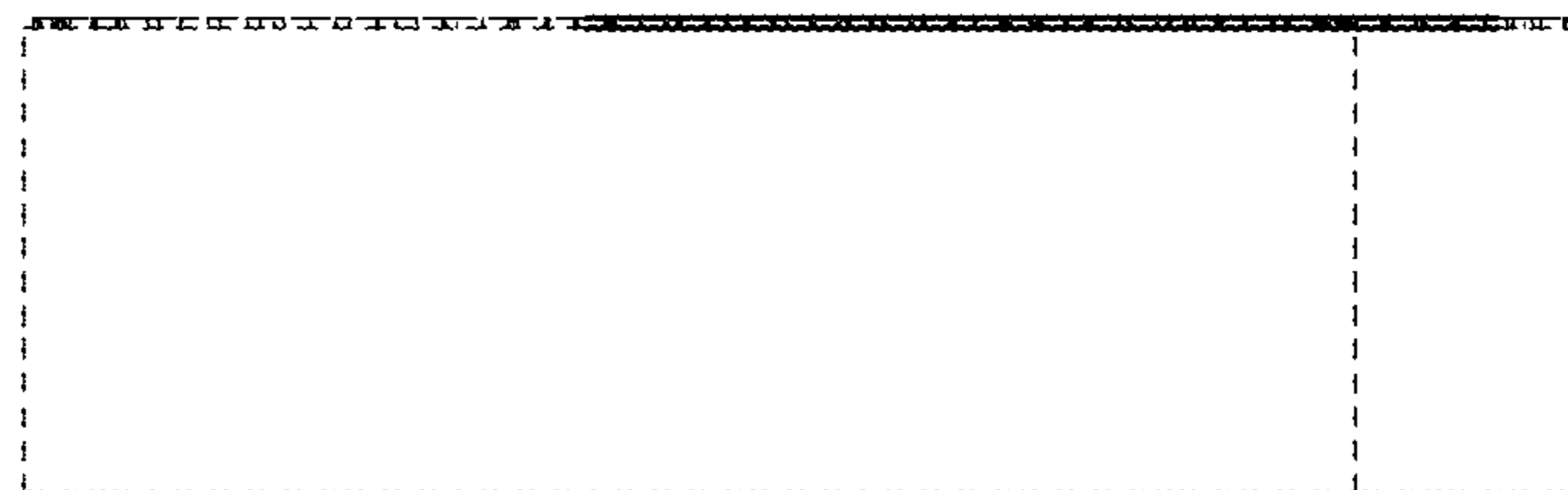

FIG. 26

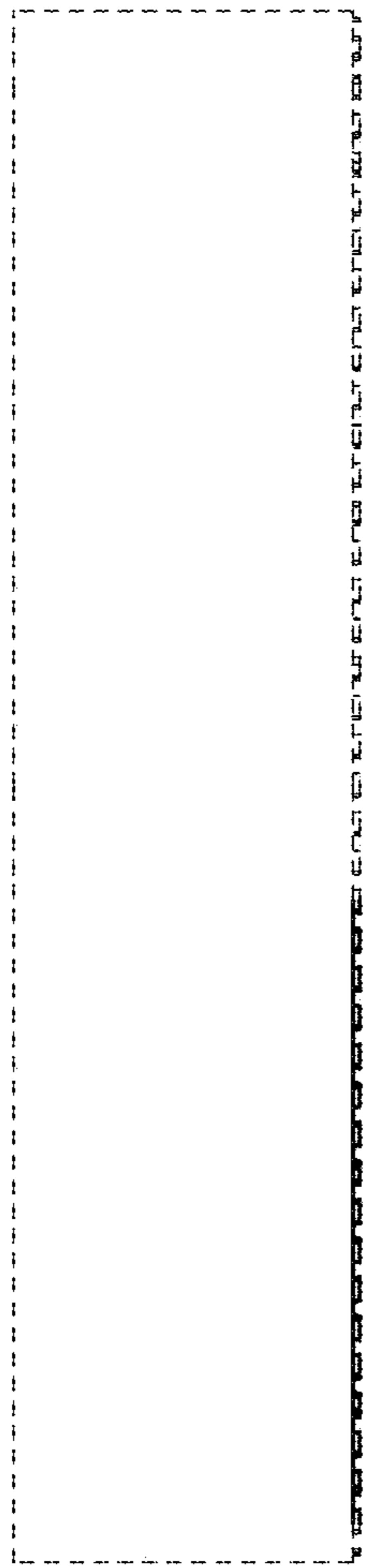

FIG. 27



FIG. 28