



US00D880401S

(12) **United States Design Patent**
Mombrinie

(10) **Patent No.:** **US D880,401 S**

(45) **Date of Patent:** **** Apr. 7, 2020**

(54) **AIRCRAFT**

(71) Applicant: **Bruno Mombrinie**, Forestville, CA (US)

(72) Inventor: **Bruno Mombrinie**, Forestville, CA (US)

(**) Term: **15 Years**

(21) Appl. No.: **29/672,543**

(22) Filed: **Dec. 6, 2018**

(51) **LOC (12) Cl.** **12-07**

(52) **U.S. Cl.**
USPC **D12/337**

(58) **Field of Classification Search**
USPC D12/319-345, 16.1, 1-4, 415, 401;
D21/436-455, 769, 771
CPC B64C 2201/146; B64C 2201/027; B64C
2201/104; B64C 25/06; B64C 25/24;
B64C 39/04; B64C 5/02
See application file for complete search history.

(56) **References Cited**

U.S. PATENT DOCUMENTS

D126,524 S *	4/1941	Eaton	D12/336
D133,635 S *	9/1942	Huzzard	D12/342
D137,285 S *	2/1944	MacCart	D12/344
D392,937 S *	3/1998	Brichard	D12/319
D446,764 S *	8/2001	Panatov	D12/324
D466,858 S *	12/2002	Carroll	D12/337
D621,774 S *	8/2010	Betsch	D12/344
D629,737 S *	12/2010	Betsch	D12/319
D717,227 S *	11/2014	Herzberger	D12/324
D725,576 S *	3/2015	Vickers	D12/3

(Continued)

OTHER PUBLICATIONS

Metro Hop. by Margo Mombrinie. dated Jan. 16, 2019. found online [Nov. 23, 2019] https://www.youtube.com/watch?v=DDXZtunQyes&feature=emb_logo.*

Primary Examiner — Marissa J Cash

(74) *Attorney, Agent, or Firm* — Craig Stainbrook; Stainbrook & Stainbrook, LLP

(57) **CLAIM**

The ornamental design for an aircraft, as shown and described.

DESCRIPTION

FIG. 1 is an upper left front perspective view of an aircraft, shown with the propellers in dashed lines;
 FIG. 2 is an upper left front perspective view, shown with the propellers removed for clarity;
 FIG. 3 is a front elevation view, shown with the propellers in dashed lines;
 FIG. 4 is a front elevation view, shown with the propellers removed for clarity;
 FIG. 5 is a rear elevation view, shown with the propellers in dashed lines;
 FIG. 6 is a right side elevation view, showing the aircraft front landing gear in a taxiing configuration;
 FIG. 7 is a top plan view;
 FIG. 8 is a bottom plan view;
 FIG. 9 is an upper perspective view of the aircraft in flight, shown with the propellers in dashed lines;
 FIG. 10 is an upper perspective view, shown with the propellers removed for clarity;
 FIG. 11 is a front elevation view, shown with the propellers in dashed lines;
 FIG. 12 is a front elevation view, shown with the propellers removed for clarity;
 FIG. 13 is a rear elevation view of the aircraft in flight, shown with the propellers in dashed lines;
 FIG. 14 is a right elevation view of the aircraft in flight, with the landing gear in a fully retracted position;
 FIG. 15 is a top plan view; and,
 FIG. 16 is a bottom plan view.
 The dashed lines represent unclaimed environment and form no part of the claimed design.

1 Claim, 14 Drawing Sheets

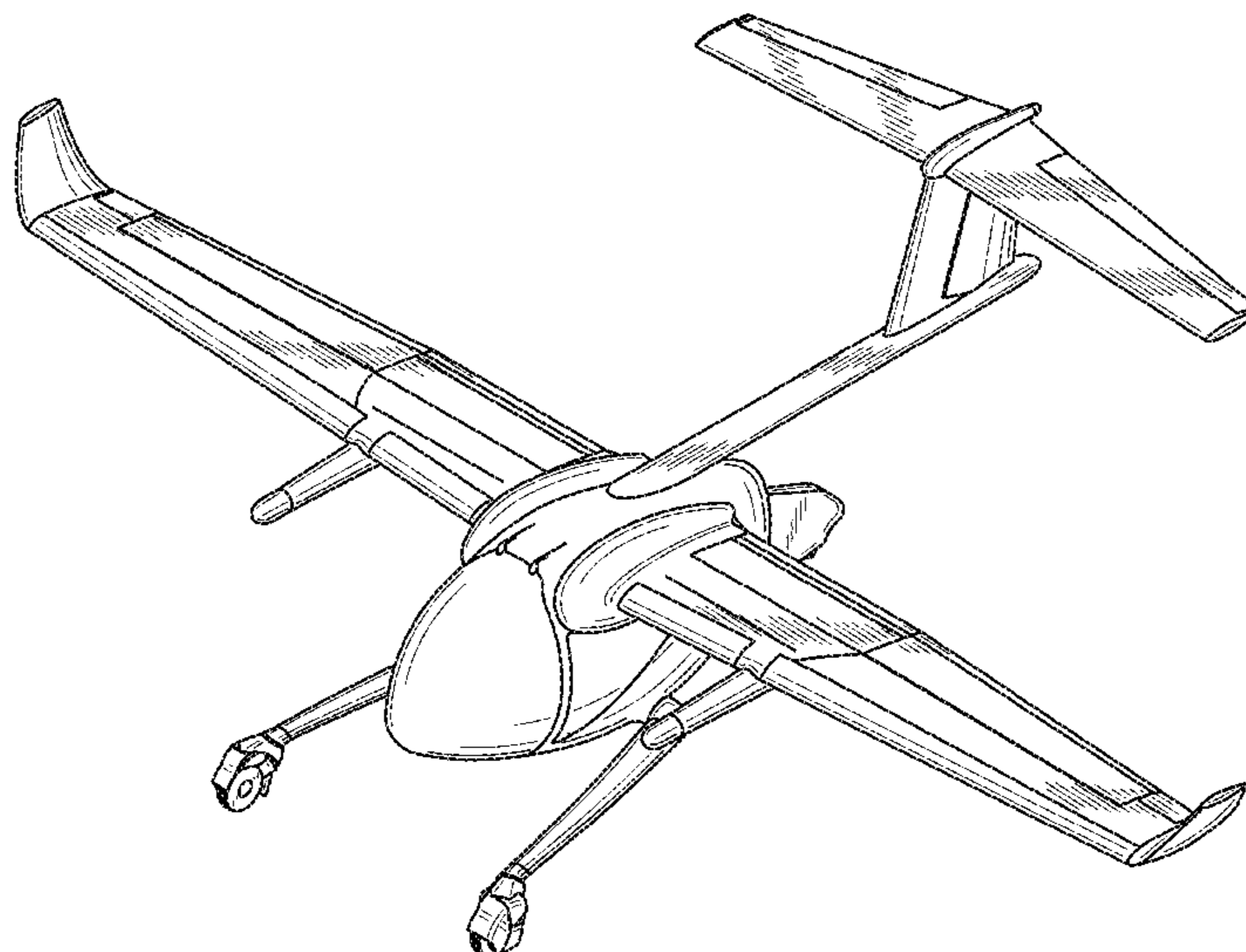

(56)

References Cited

U.S. PATENT DOCUMENTS

D739,807 S *	9/2015	Strand	D12/324
D763,733 S *	8/2016	Gattelli	D12/16.1
D795,160 S *	8/2017	Koppenwallner	D12/343
D799,402 S *	10/2017	Cummings	D12/327
D803,724 S *	11/2017	Zhou	D12/16.1
D807,273 S *	1/2018	Koppenwallner	D12/337
D808,328 S *	1/2018	Ivans	D12/328
D809,448 S *	2/2018	Schmiderer	D12/344
D816,583 S *	5/2018	Dutertre	D12/328
D822,579 S *	7/2018	Lienhard	D12/328
D832,141 S *	10/2018	Ferner	D12/16.1
D833,364 S *	11/2018	Schmiderer	D12/344
D843,305 S *	3/2019	MacAndrew	D12/319
D850,357 S *	6/2019	Cummings	D12/326

* cited by examiner

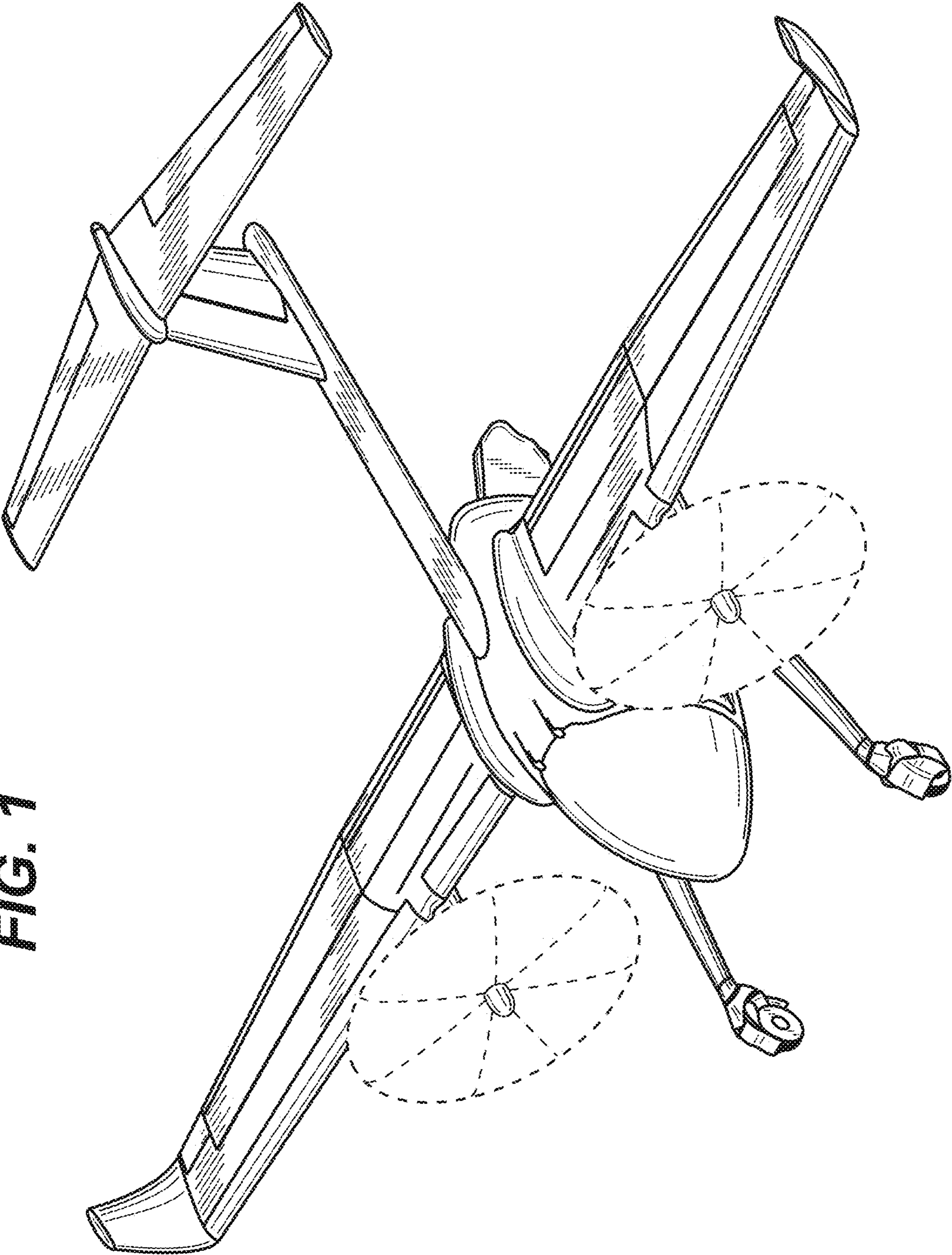

FIG. 1

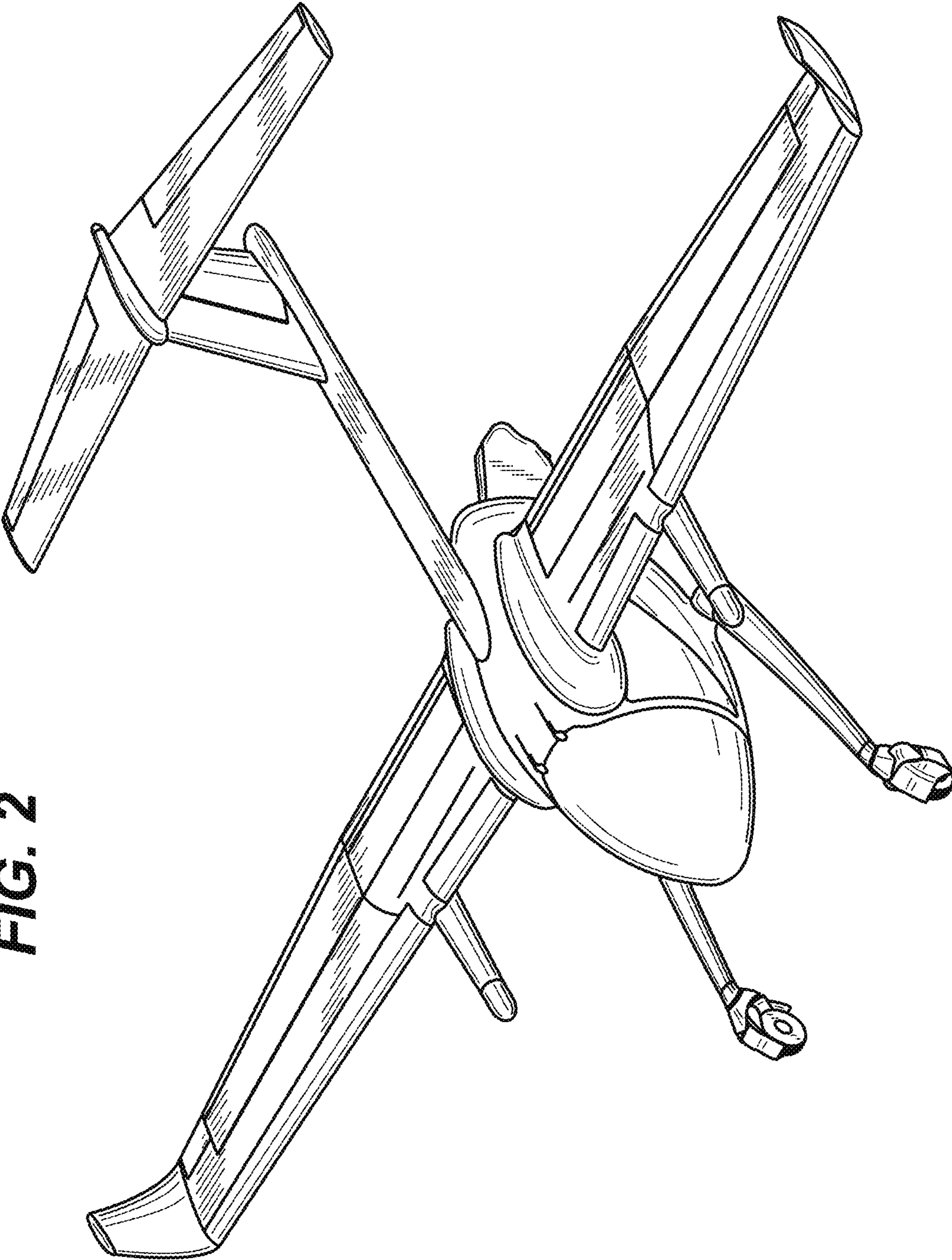
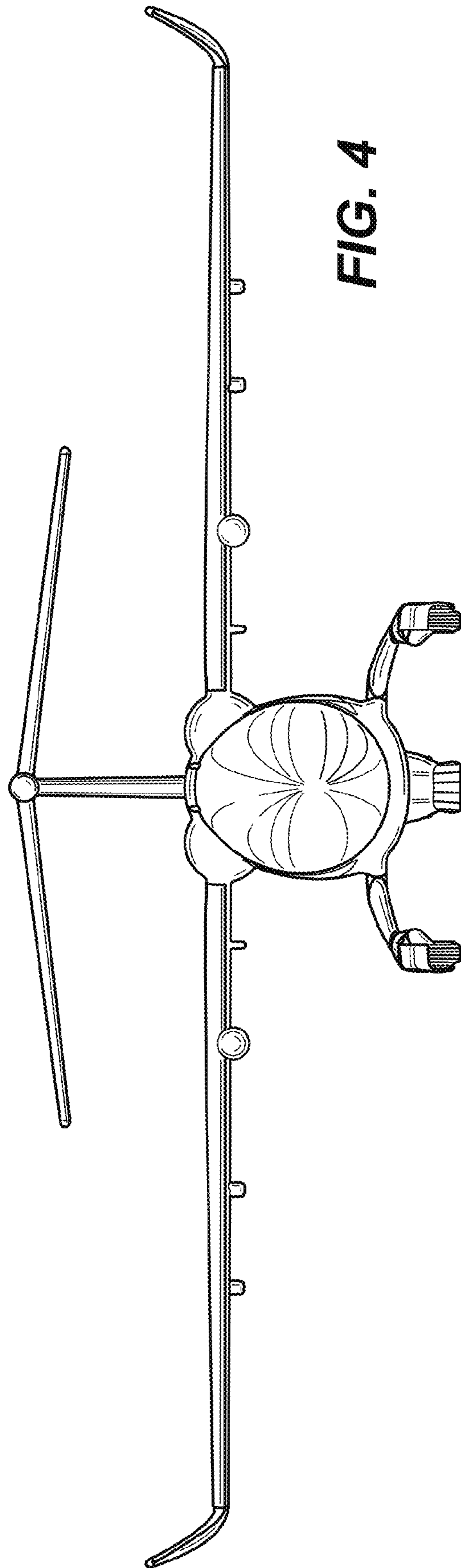
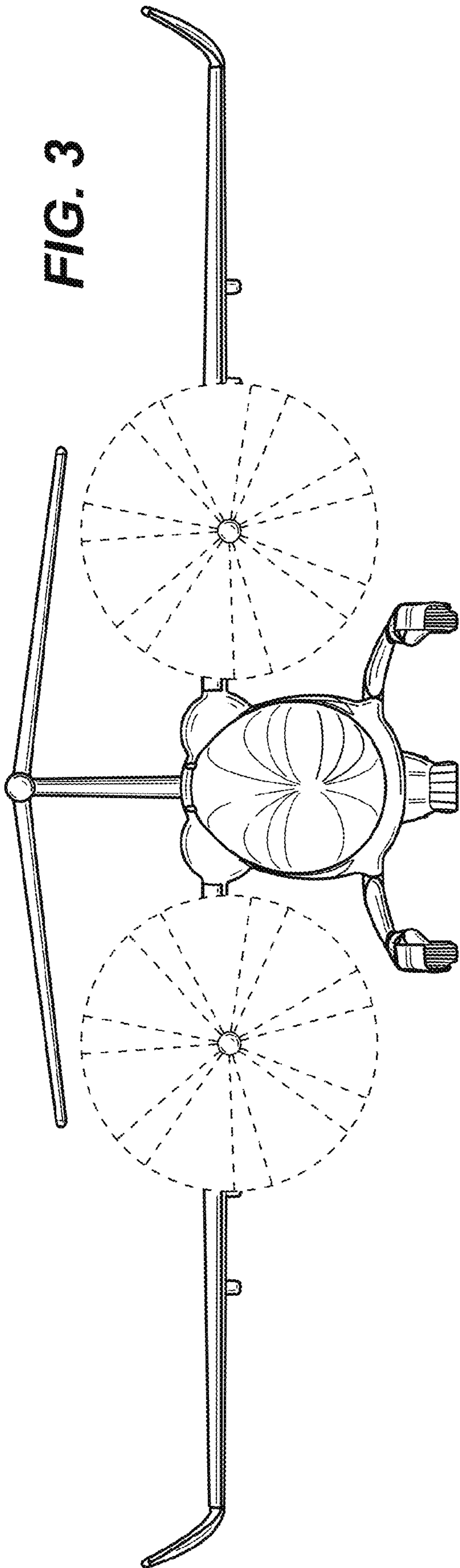
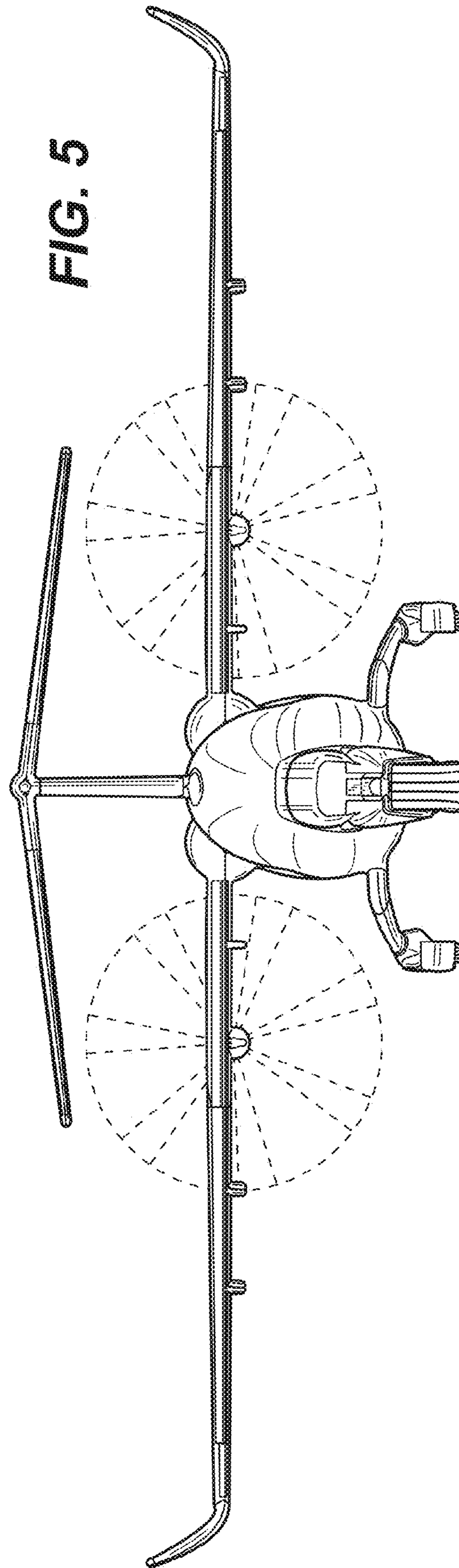

FIG. 2





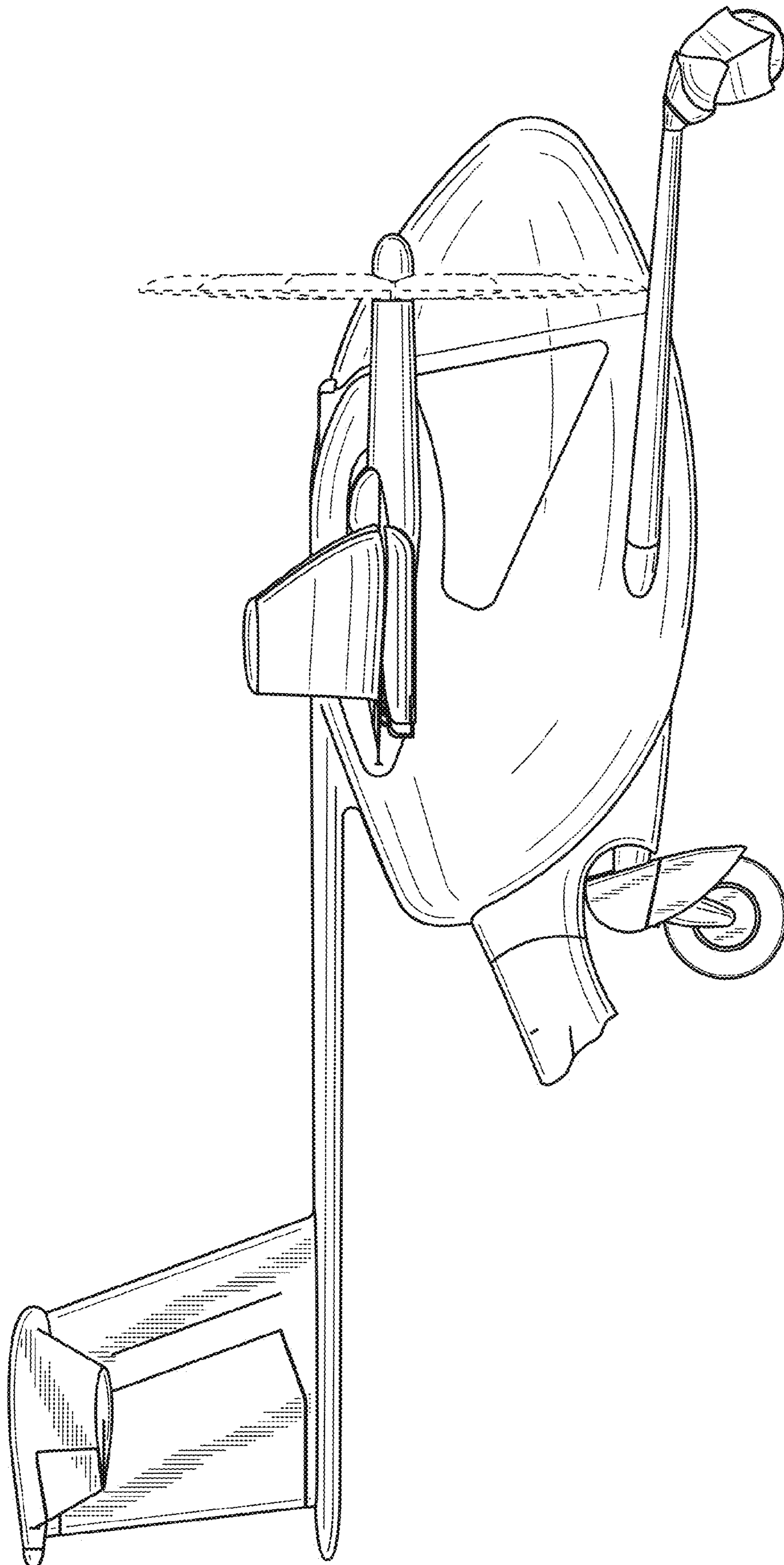

FIG. 6

FIG. 7

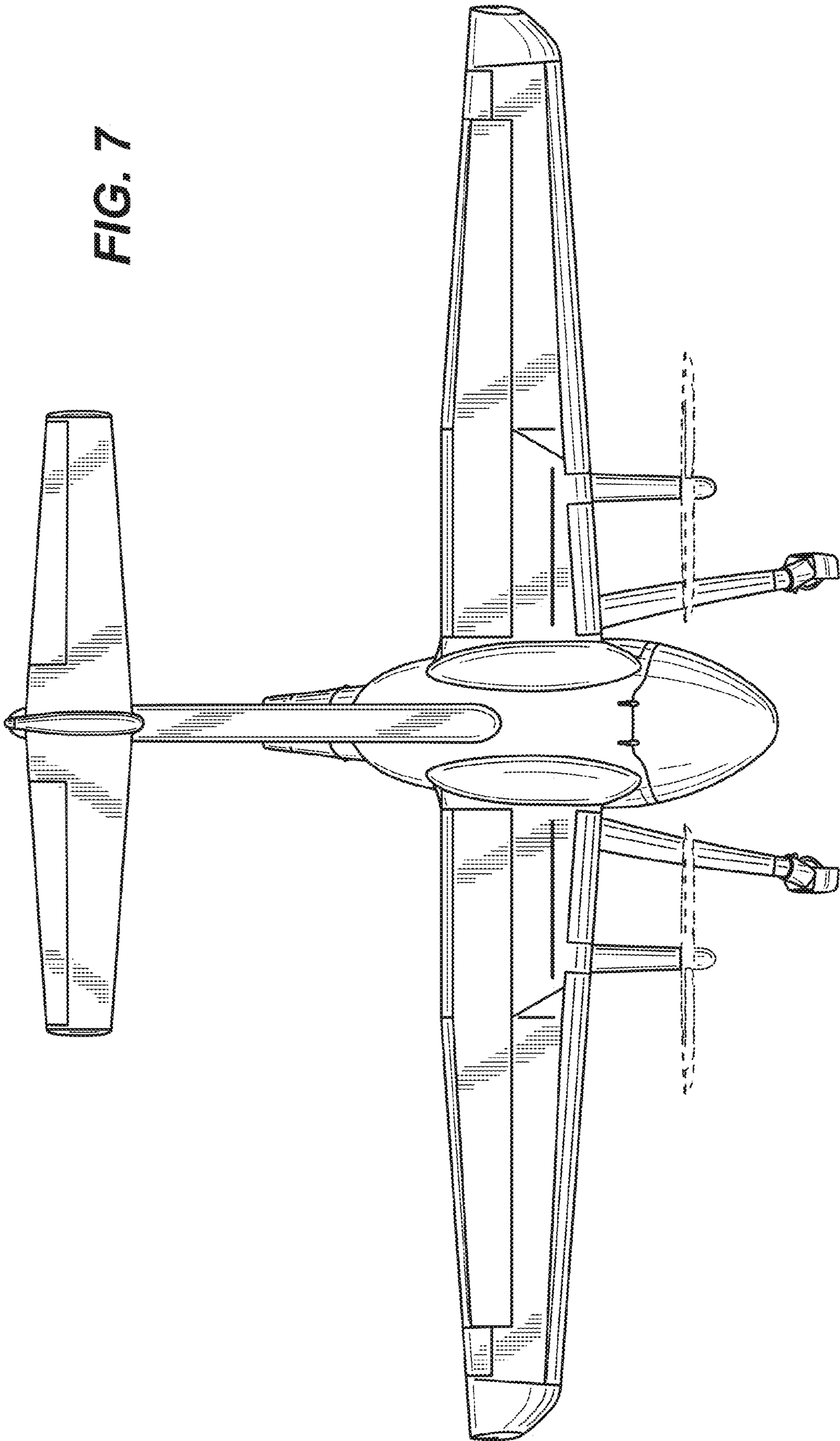
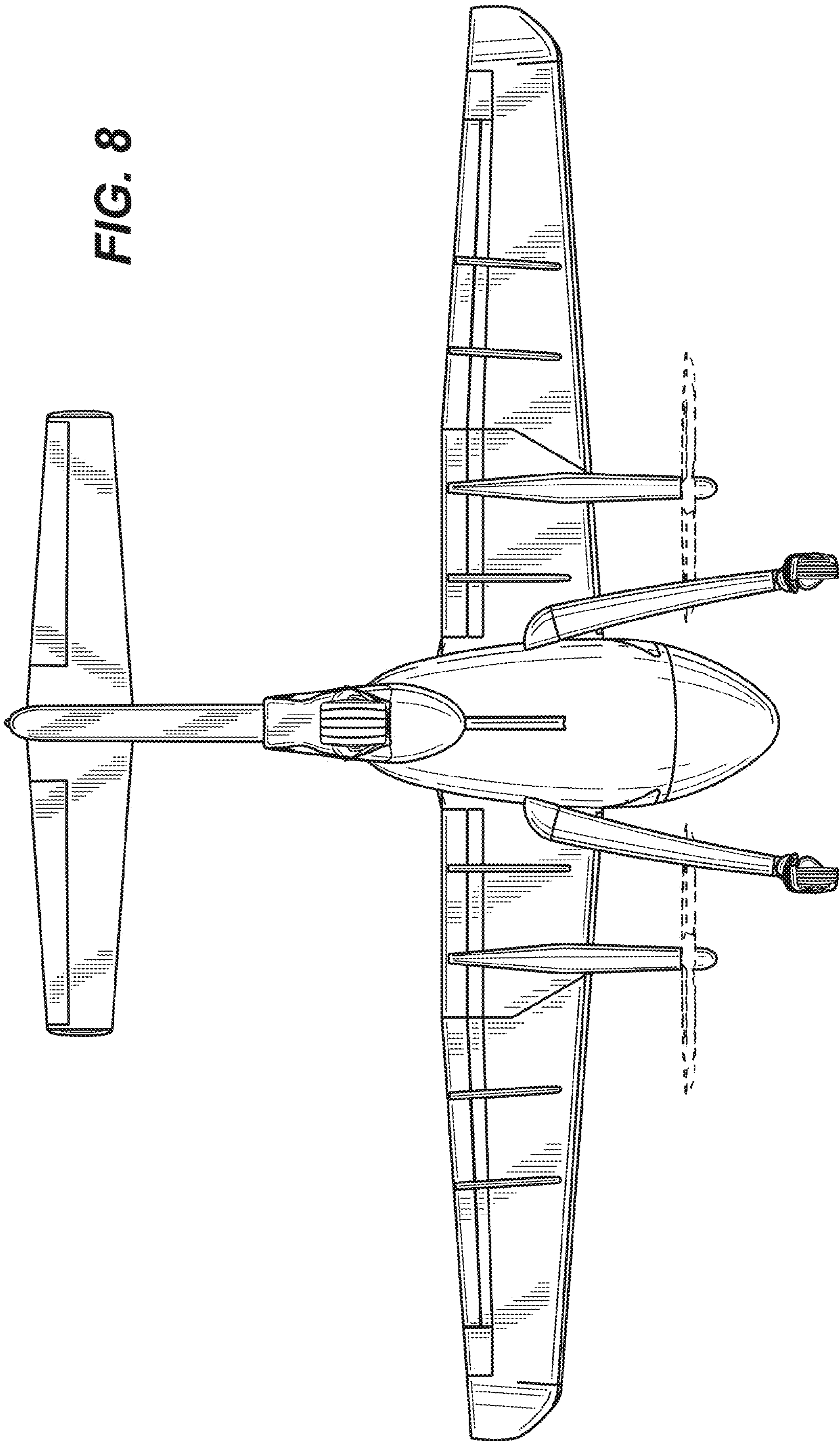

FIG. 8



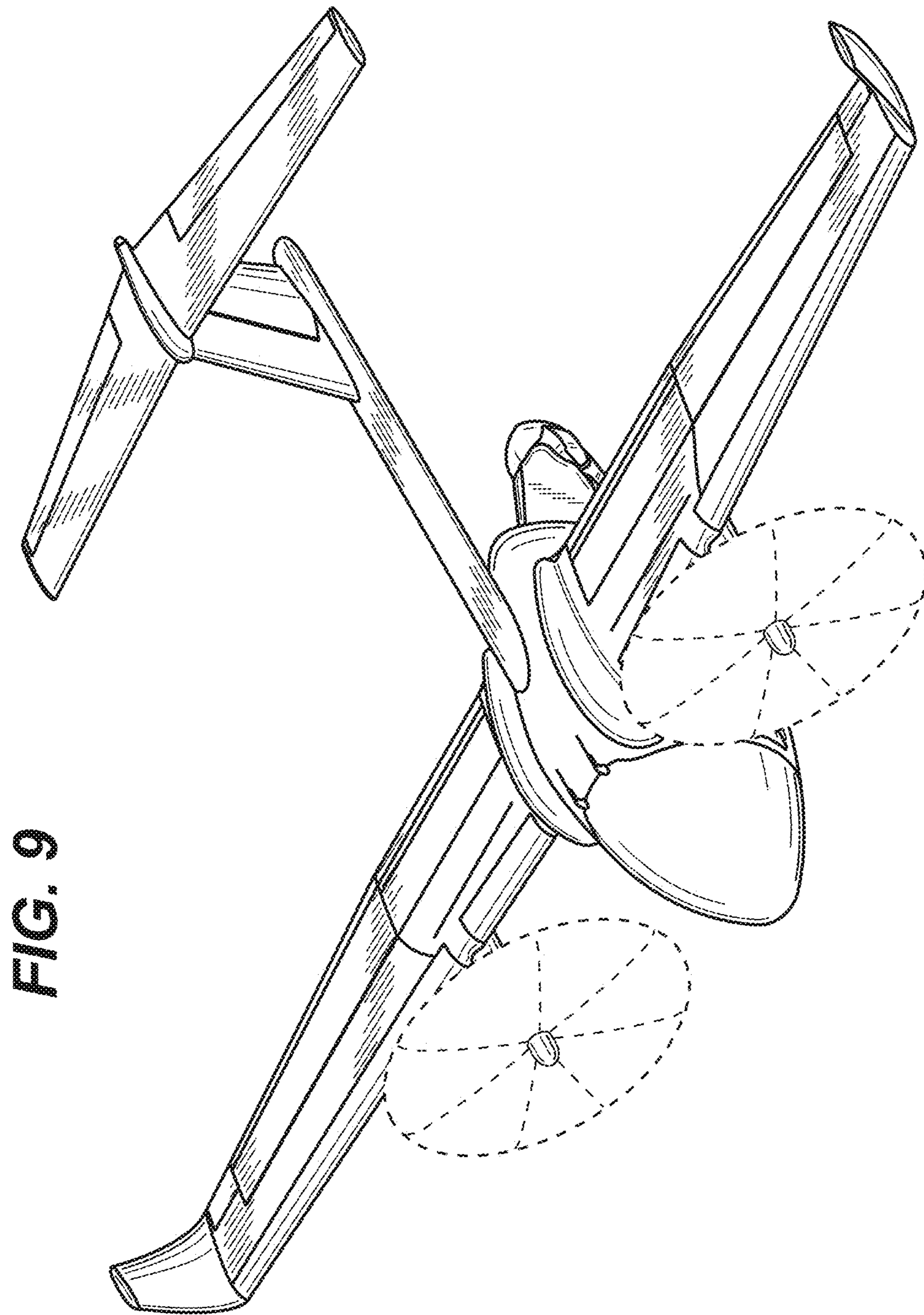

FIG. 9

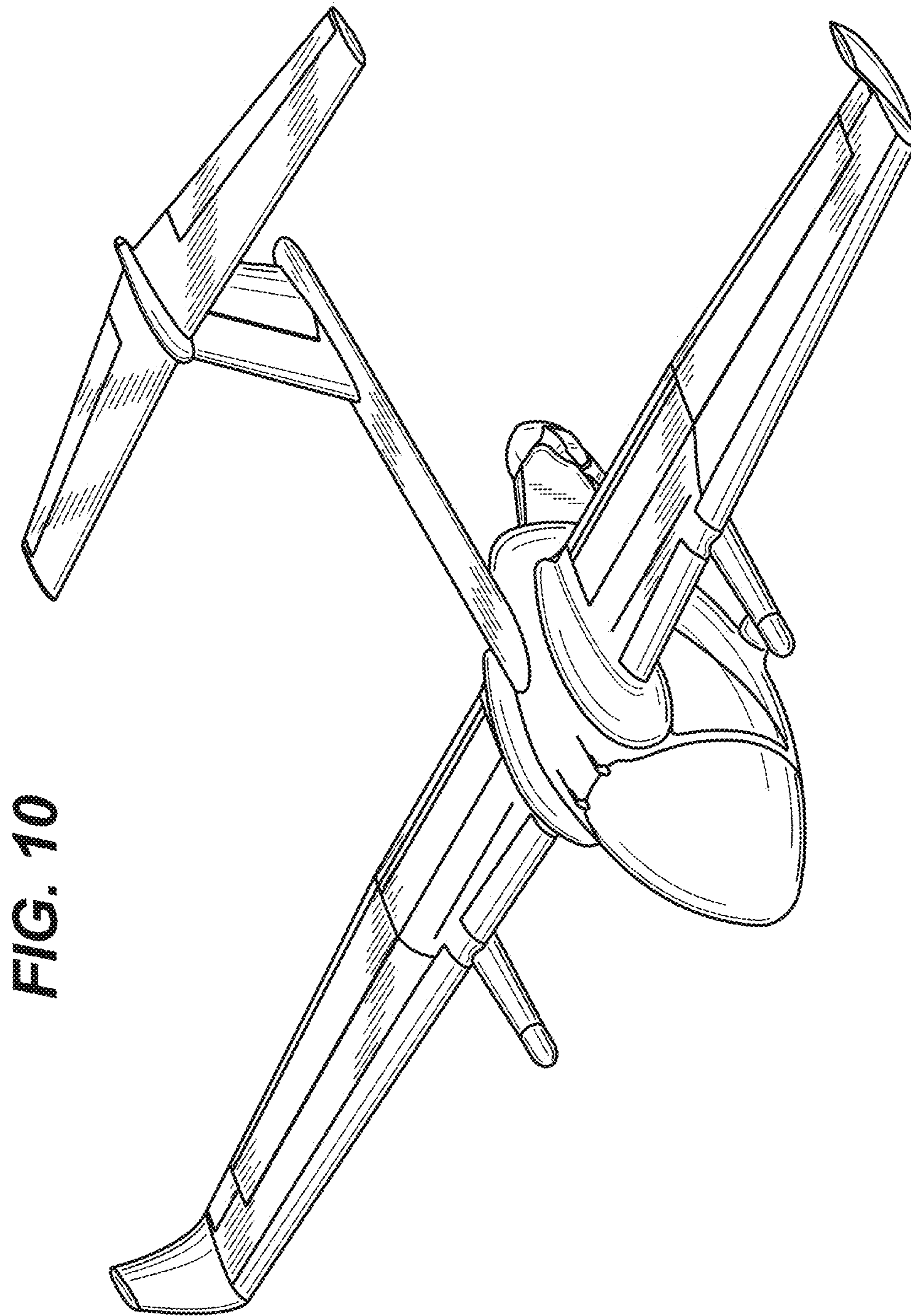

FIG. 10

FIG. 11

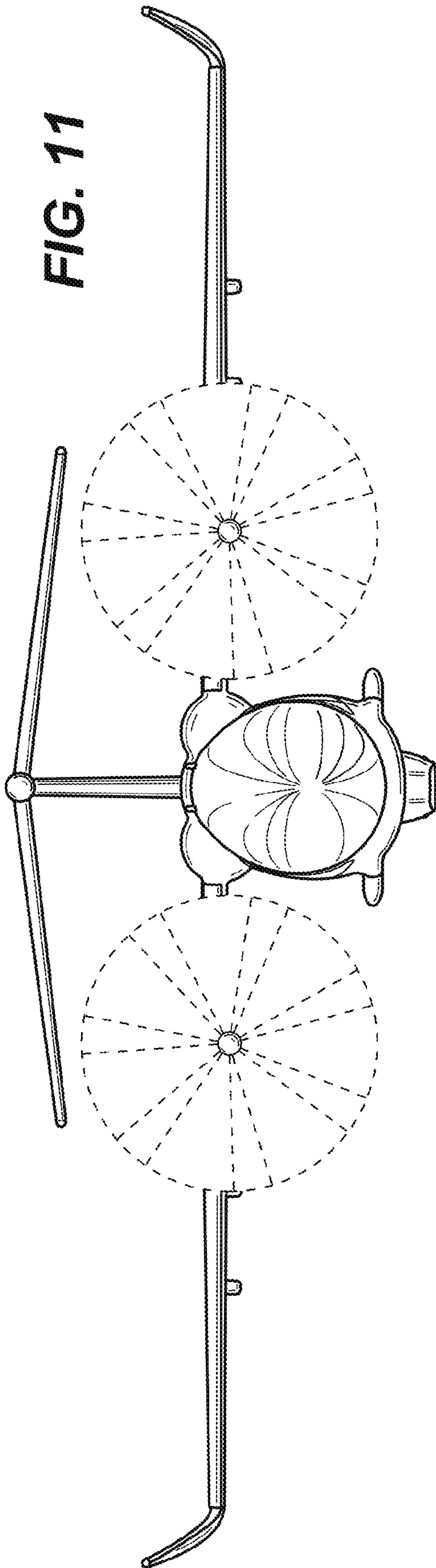

FIG. 12

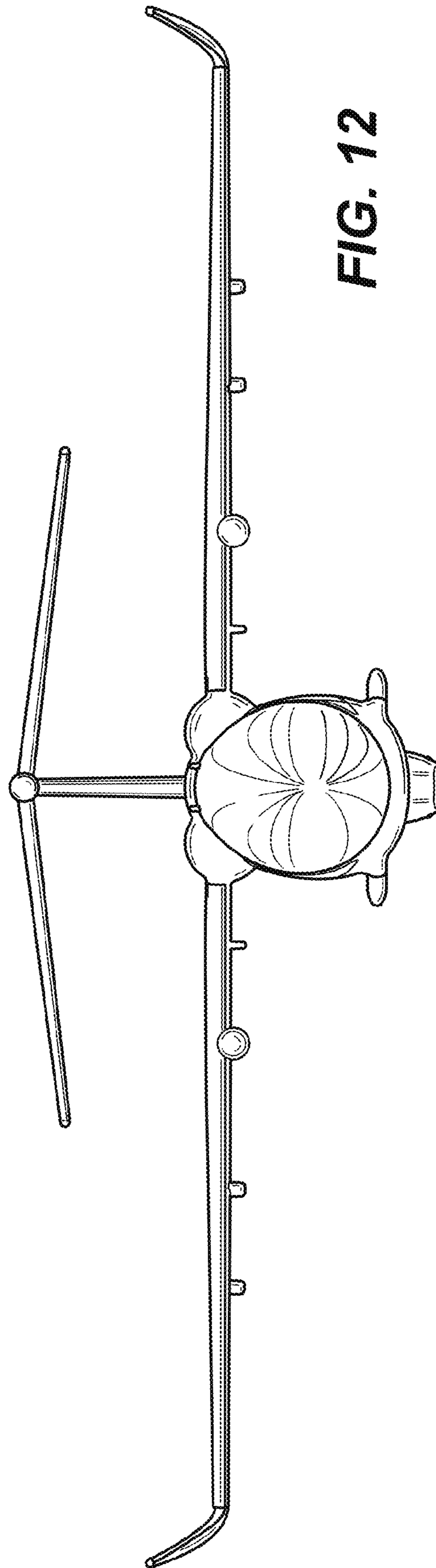
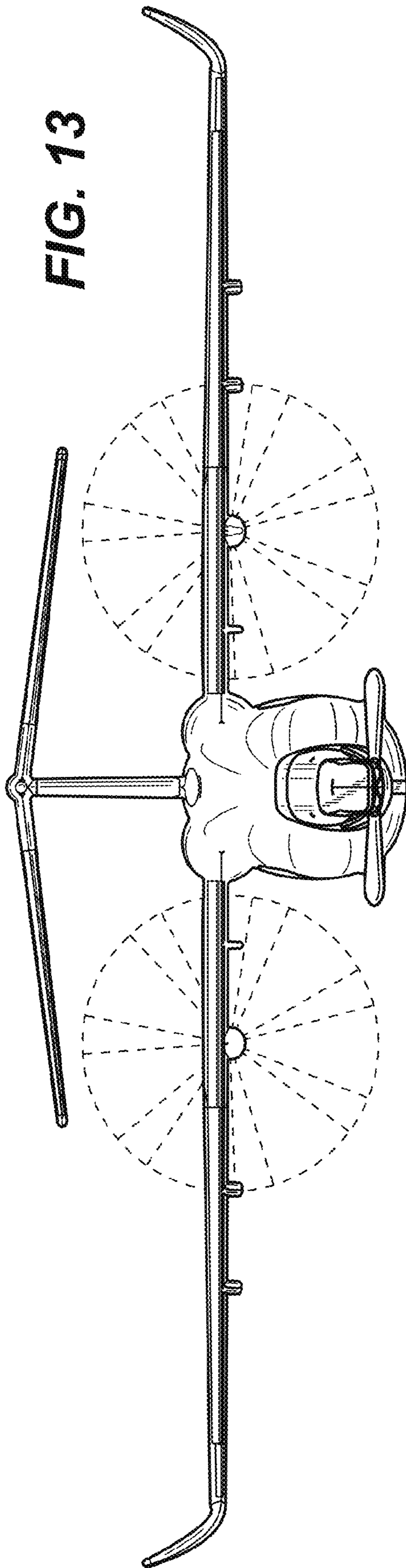

FIG. 13



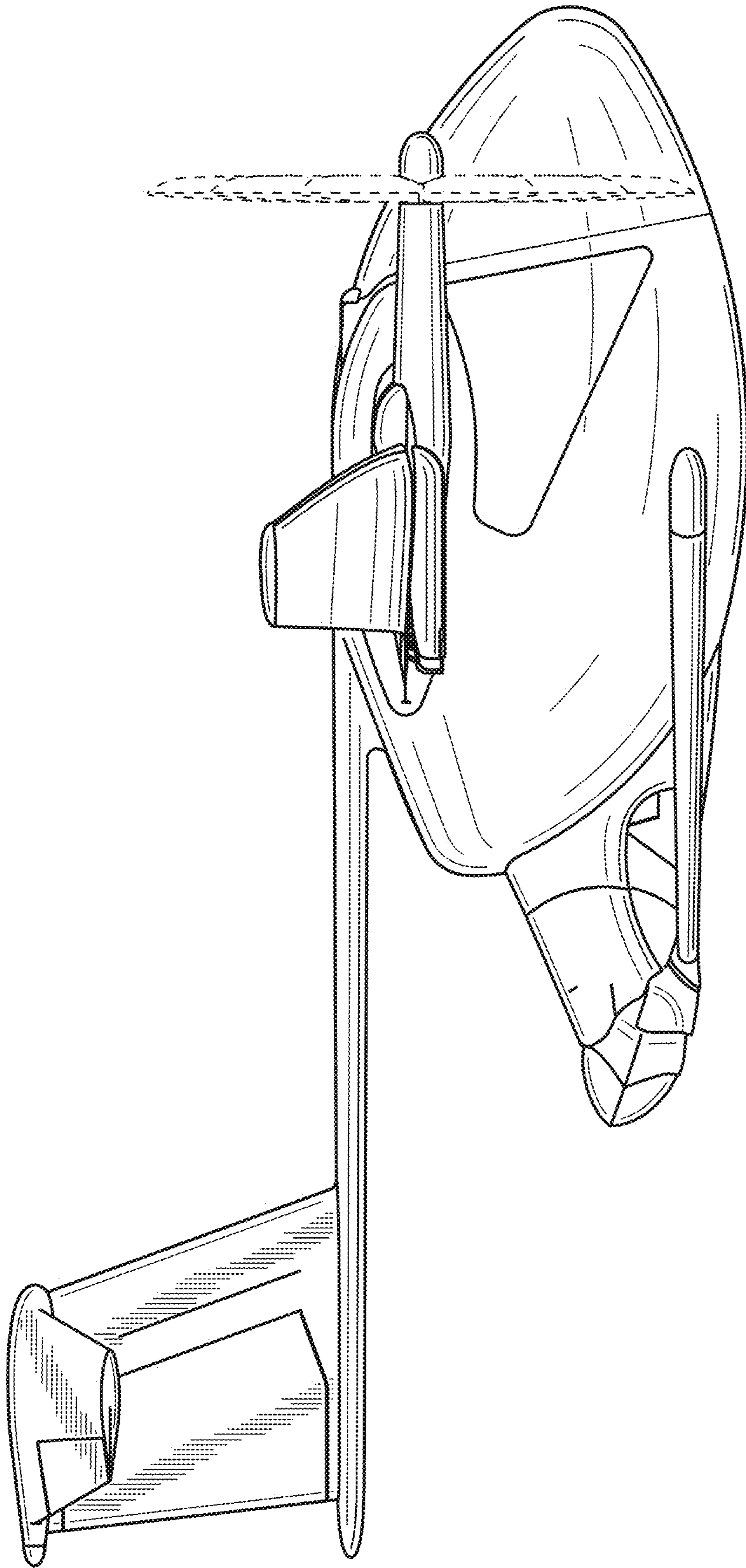

FIG. 14

FIG. 15

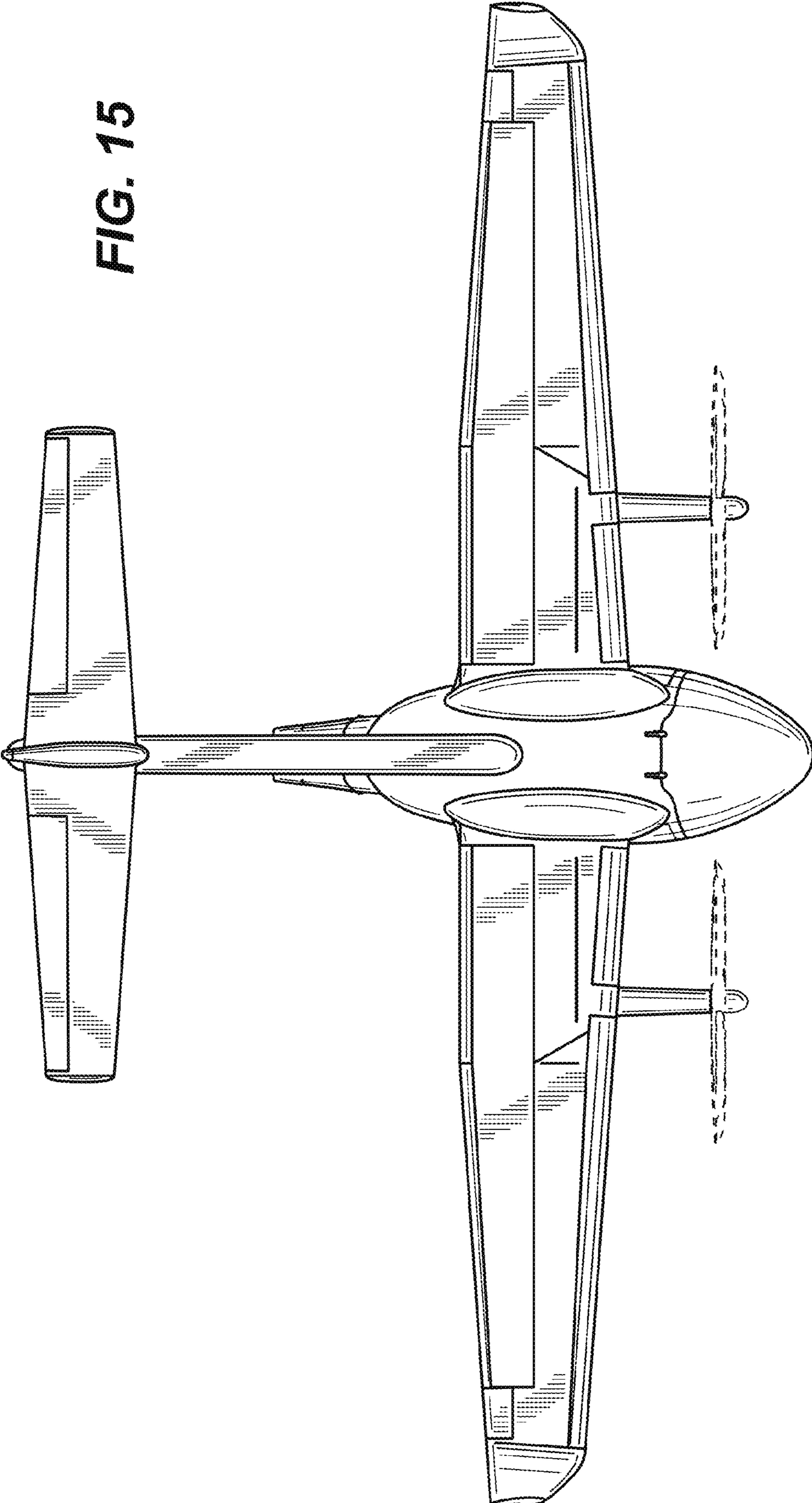

FIG. 16

