



US00D880400S

(12) **United States Design Patent** (10) **Patent No.:** **US D880,400 S**  
**MacAndrew et al.** (45) **Date of Patent:** **\*\* Apr. 7, 2020**

(54) **FLYING CAR**  
 (71) Applicant: **AEROMOBIL R&D, S. R. O.**,  
 Bratislava (SK)  
 (72) Inventors: **Kenneth Douglas Alexander**  
**MacAndrew**, Záhorská Bystrica (SK);  
**Tomas Urik**, Sastin-Straze (SK); **Adam**  
**Danko**, Stupava (SK); **Frantisek**  
**Valent**, Klacany (SK)

D489,315 S \* 5/2004 Dauvergne ..... D12/319  
 D493,411 S \* 7/2004 Fong ..... D12/319  
 D498,201 S \* 11/2004 Moller ..... D12/319  
 D543,928 S \* 6/2007 Sanders, Jr. .... B64C 27/12  
 D12/319  
 D583,293 S \* 12/2008 Frost ..... D12/319  
 D697,019 S \* 1/2014 Friesel ..... D12/319  
 D709,430 S \* 7/2014 Schwaiger ..... D12/16.1  
 D843,304 S \* 3/2019 MacAndrew ..... D12/319  
 D843,305 S \* 3/2019 MacAndrew ..... D12/319  
 D843,306 S \* 3/2019 Tzarnotzky ..... D12/329

(Continued)

(\*\*) Term: **15 Years**

Primary Examiner — Darlington Ly

(21) Appl. No.: **35/505,927**

(22) Filed: **Aug. 20, 2018**

(57) **CLAIM**

The ornamental design for a flying car, as shown and described.

(80) **Hague Agreement Data**

Int. Filing Date: **Aug. 20, 2018**  
 Int. Reg. No.: **DM/103200**  
 Int. Reg. Date: **Aug. 20, 2018**  
 Int. Reg. Pub. Date: **Oct. 26, 2018**

**DESCRIPTION**

(30) **Foreign Application Priority Data**

Feb. 20, 2018 (EM) ..... 004717189

(51) **LOC (12) Cl.** ..... **12-07**

(52) **U.S. Cl.**  
 USPC ..... **D12/319**

(58) **Field of Classification Search**  
 USPC ..... D12/16.1, 319–322, 324–327, 330,  
 D12/333–345; D21/430, 436, 437,  
 D21/441–449, 451  
 CPC . B60F 5/02; B64C 27/14; B64C 27/08; B64C  
 37/00

See application file for complete search history.

- 1.1 : Top, front perspective view of a first embodiment of a flying car in a first state;
- 1.2 : Top, front perspective view thereof in a second state;
- 1.3 : Front view thereof in the first state;
- 1.4 : Right-side view thereof in the first state. A left-side view of the flying car is substantially a mirror image of the right-side view, and therefore omitted;
- 1.5 : Back view thereof in the first state;
- 1.6 : Top view thereof in the first state;
- 1.7 : Top view thereof in the second state;
- 2.1 : Top, front perspective view of a second embodiment of a flying car in a first state;
- 2.2 : Top, front perspective view thereof in a second state;
- 2.3 : Front view thereof in the first state;
- 2.4 : Right-side view thereof in the first state. A left-side view of the flying car is substantially a mirror image of the right-side view, and therefore omitted;
- 2.5 : Back view thereof in the first state;
- 2.6 : Top view thereof in the first state; and
- 2.7 : Top view thereof in the second state

(56) **References Cited**

**U.S. PATENT DOCUMENTS**

3,090,581 A \* 5/1963 Einarsson ..... B64C 37/00  
 244/2  
 D462,046 S \* 8/2002 Fong ..... D12/319

**1 Claim, 14 Drawing Sheets**

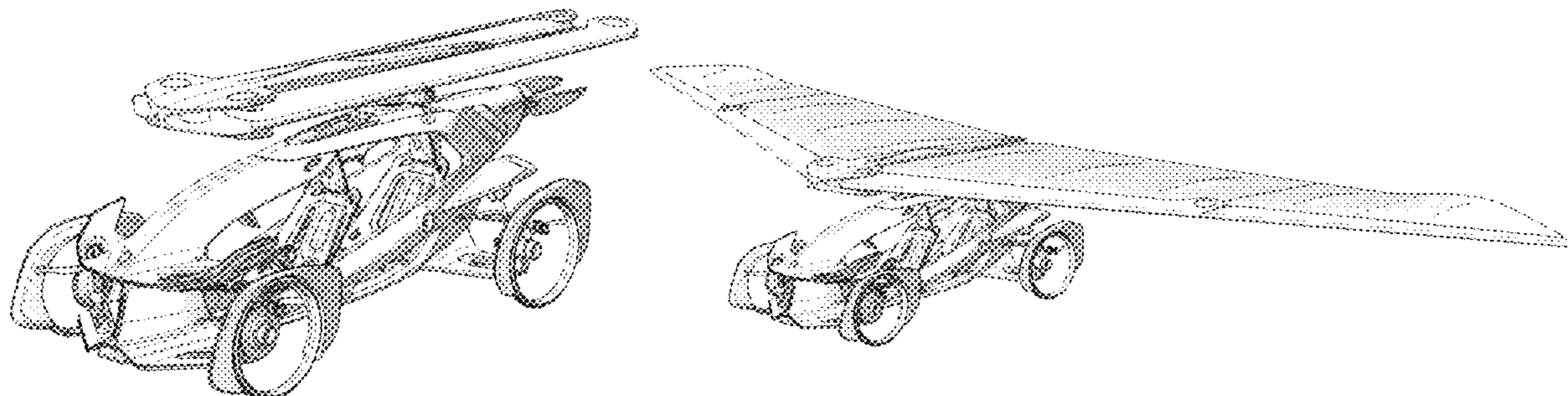

(56)

**References Cited**

U.S. PATENT DOCUMENTS

D843,919 S \* 3/2019 Tzarnotzky ..... D12/329  
D844,537 S \* 4/2019 MacAndrew ..... D12/319  
2011/0042507 A1\* 2/2011 Seiford, Sr. .... B60F 5/02  
244/2  
2016/0243910 A1\* 8/2016 Hu ..... B60F 5/02  
2017/0072755 A1\* 3/2017 Zhou ..... B64C 29/0075  
2017/0240270 A1\* 8/2017 Nam ..... B60F 5/02  
2018/0056743 A1\* 3/2018 Zhou ..... B64D 17/80  
2018/0065435 A1\* 3/2018 Barot ..... B64C 37/00

\* cited by examiner

1.1

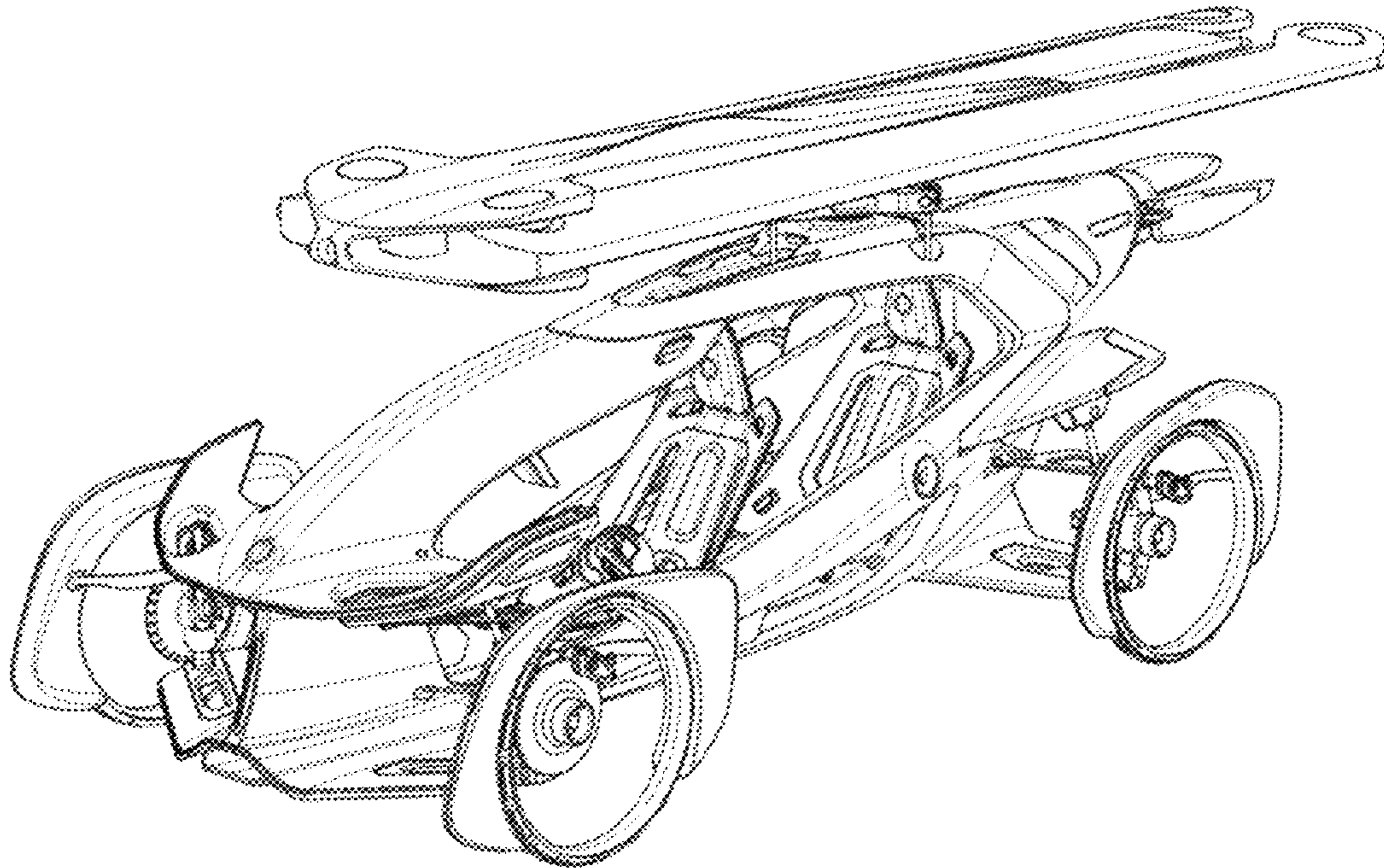

1.2

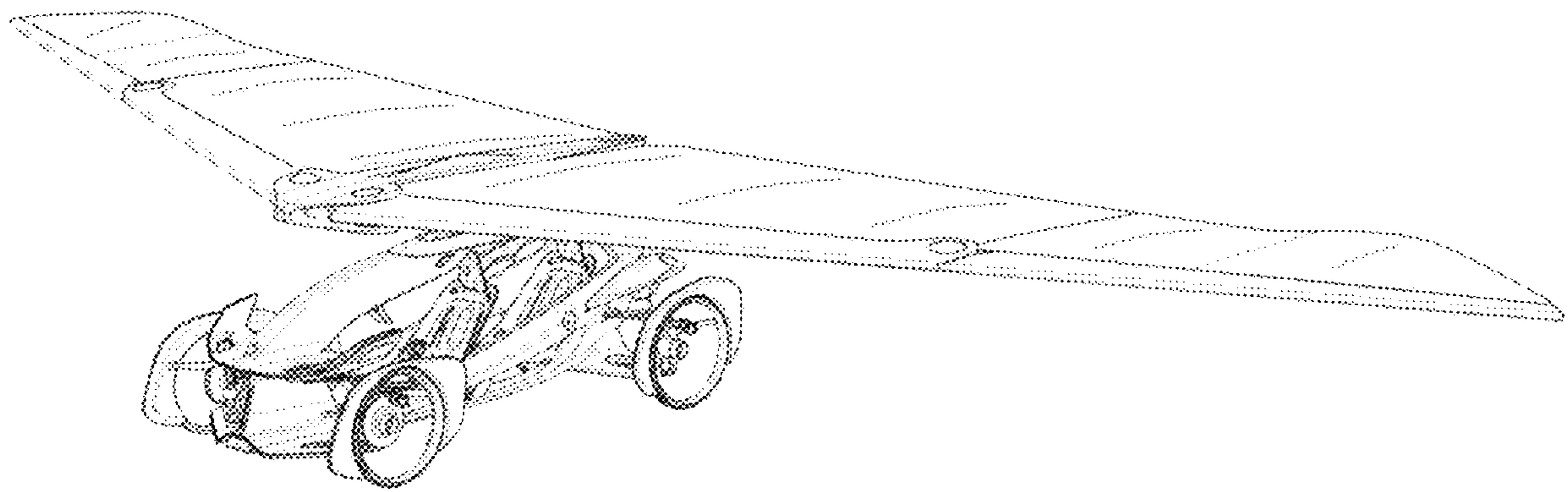



1.3

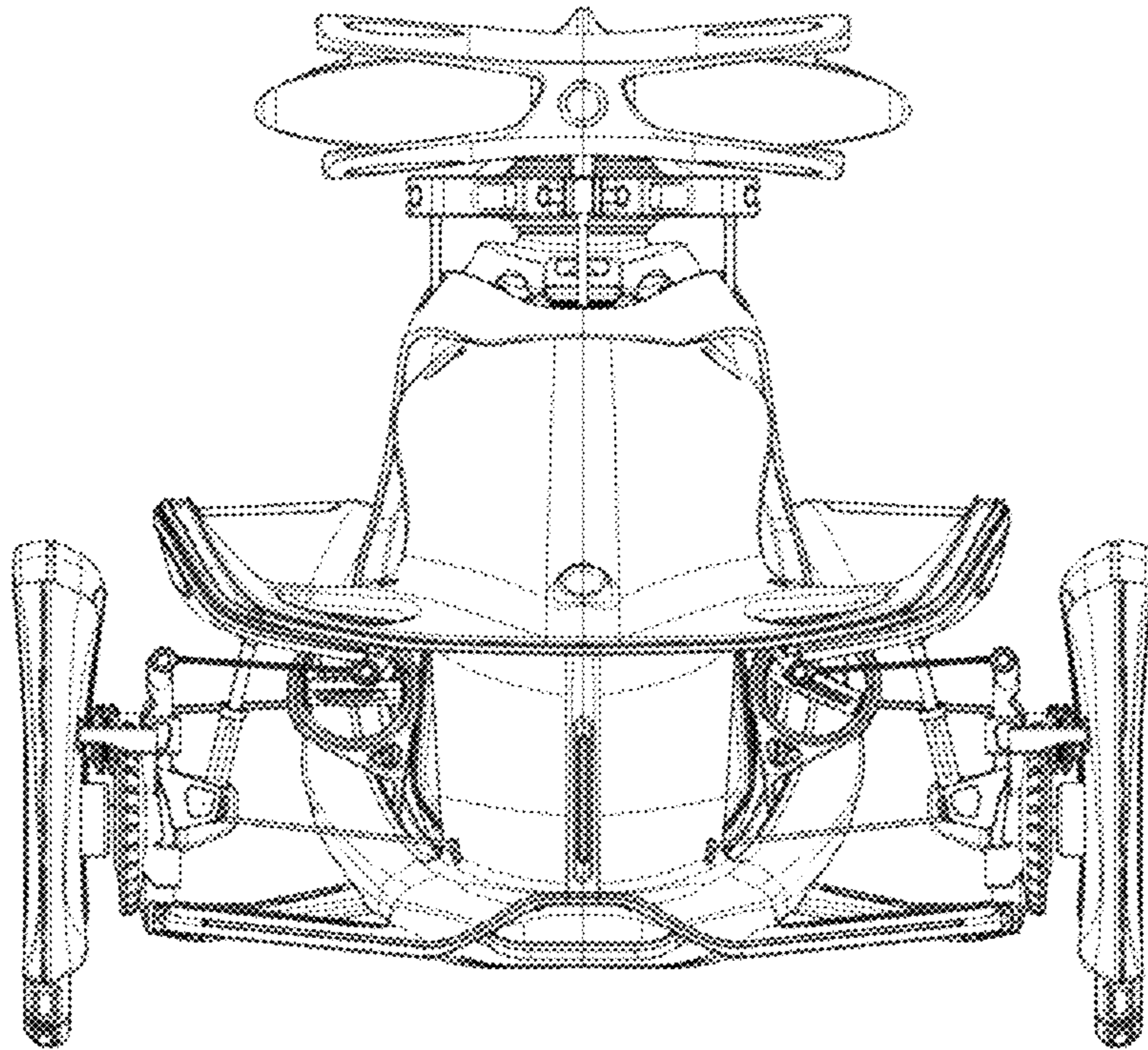

1.4

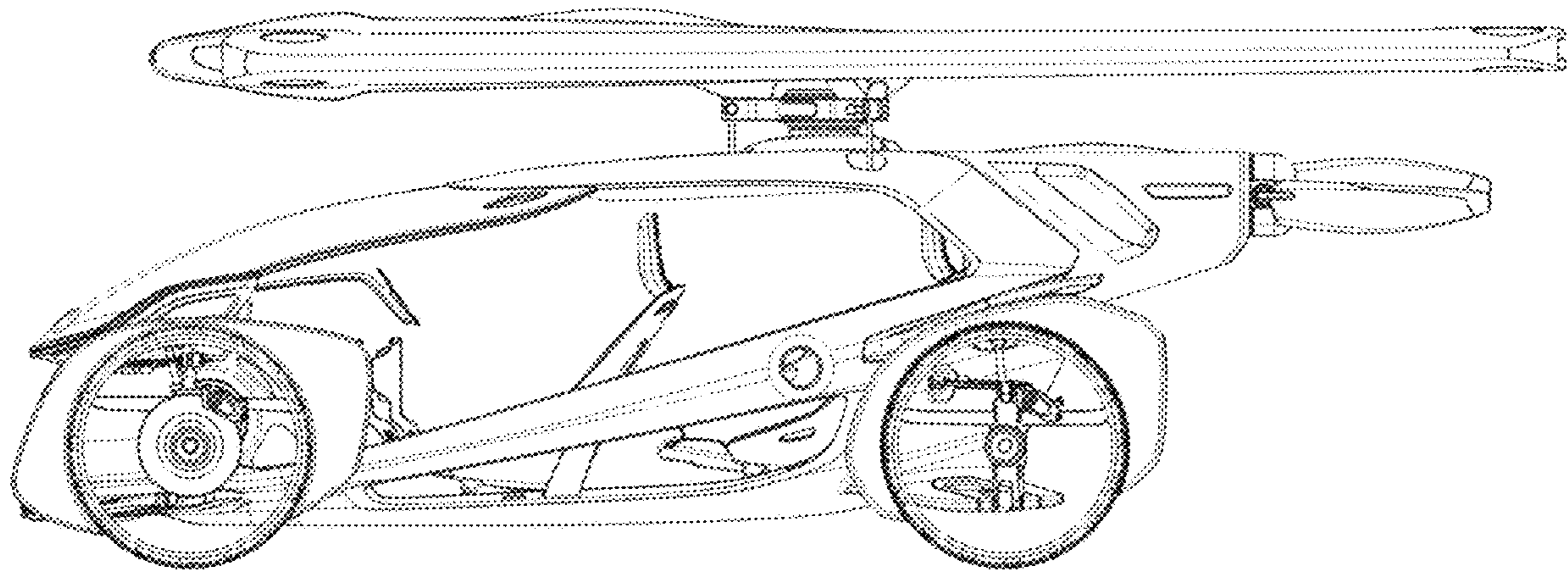

1.5

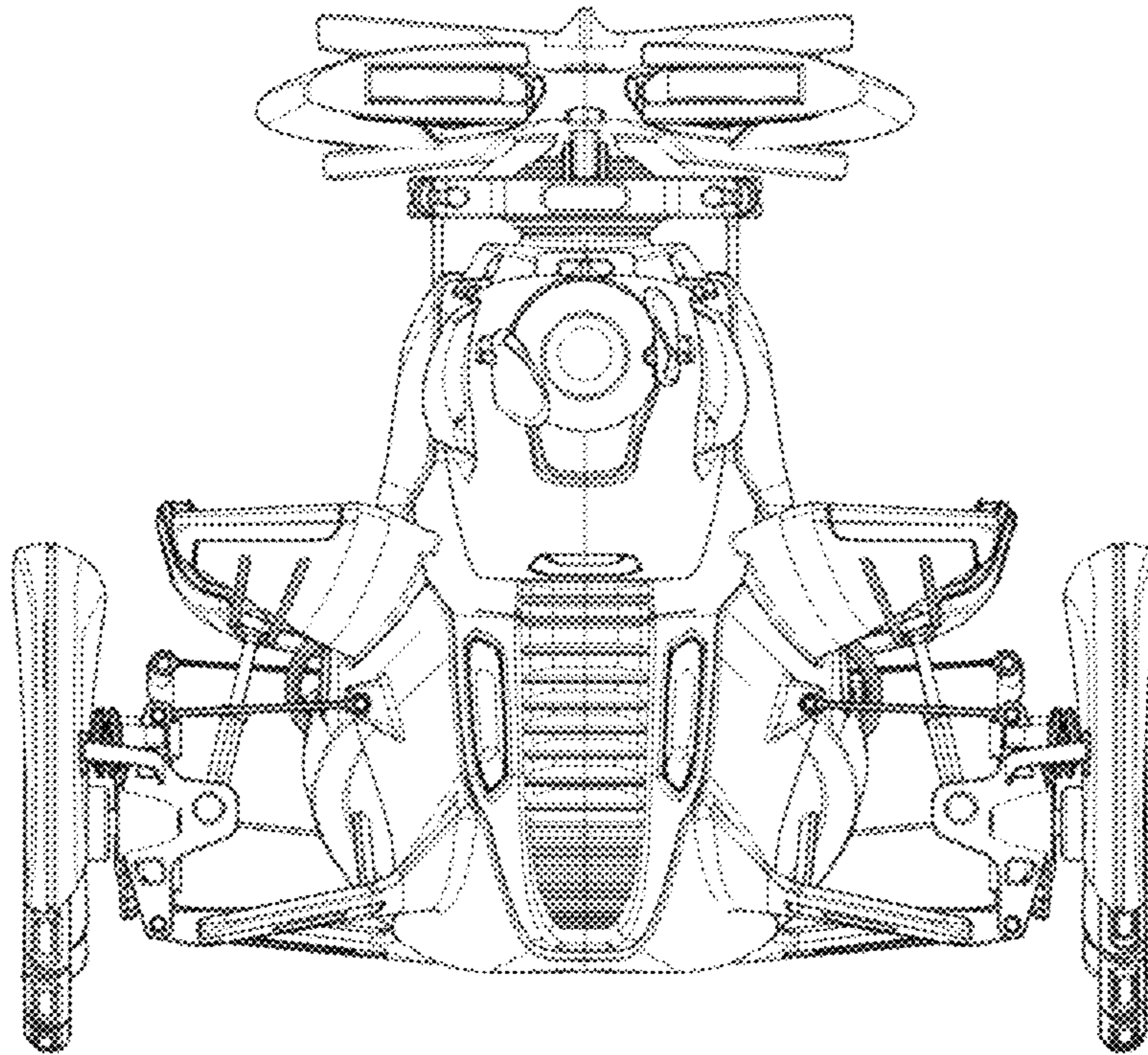

1.6

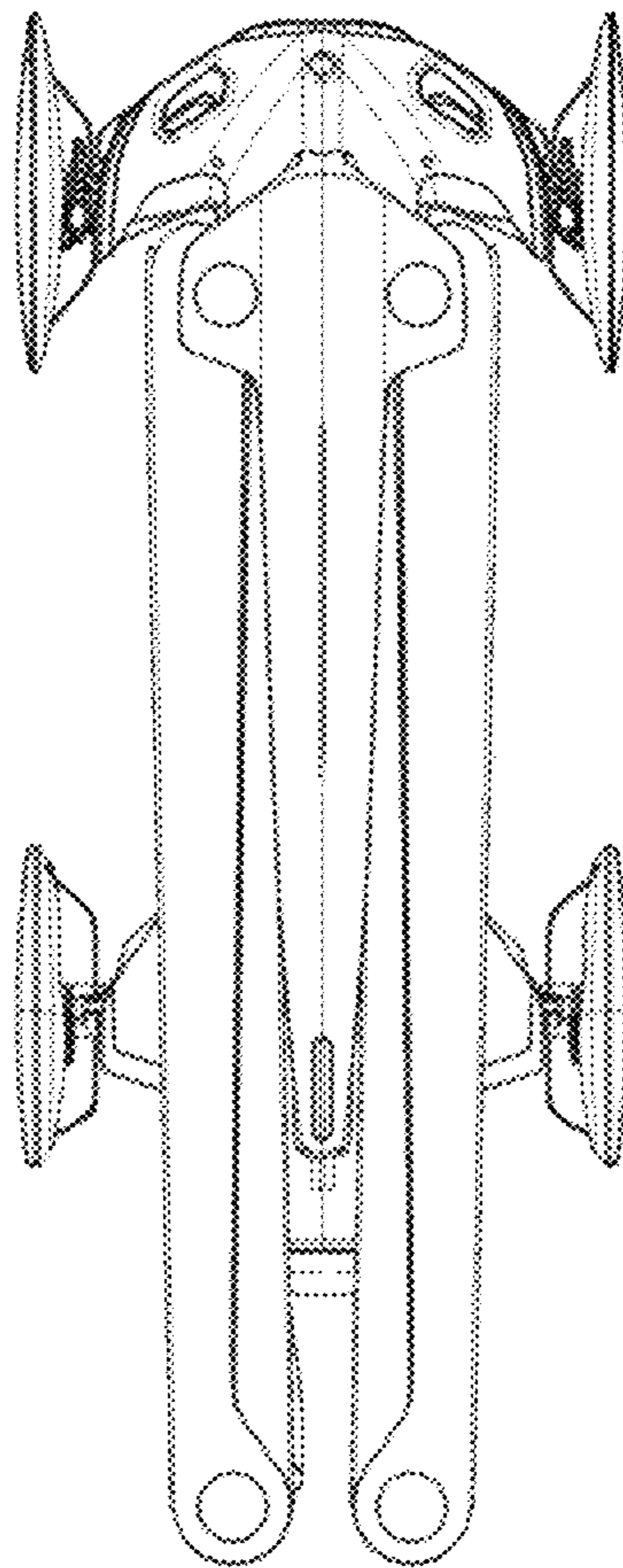



1.7

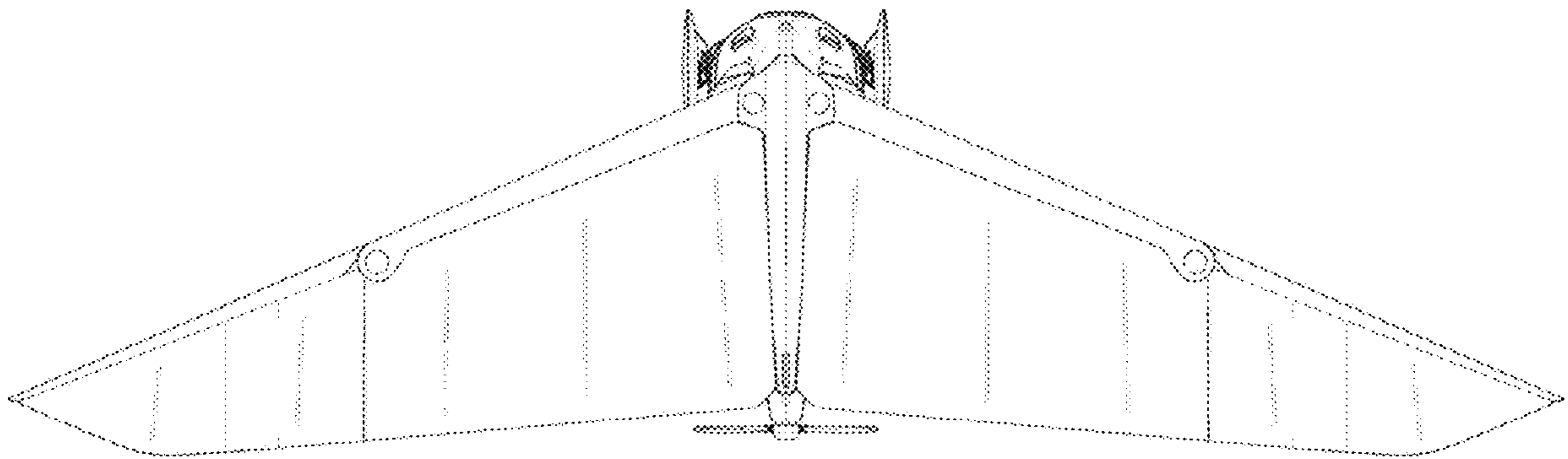

2.1

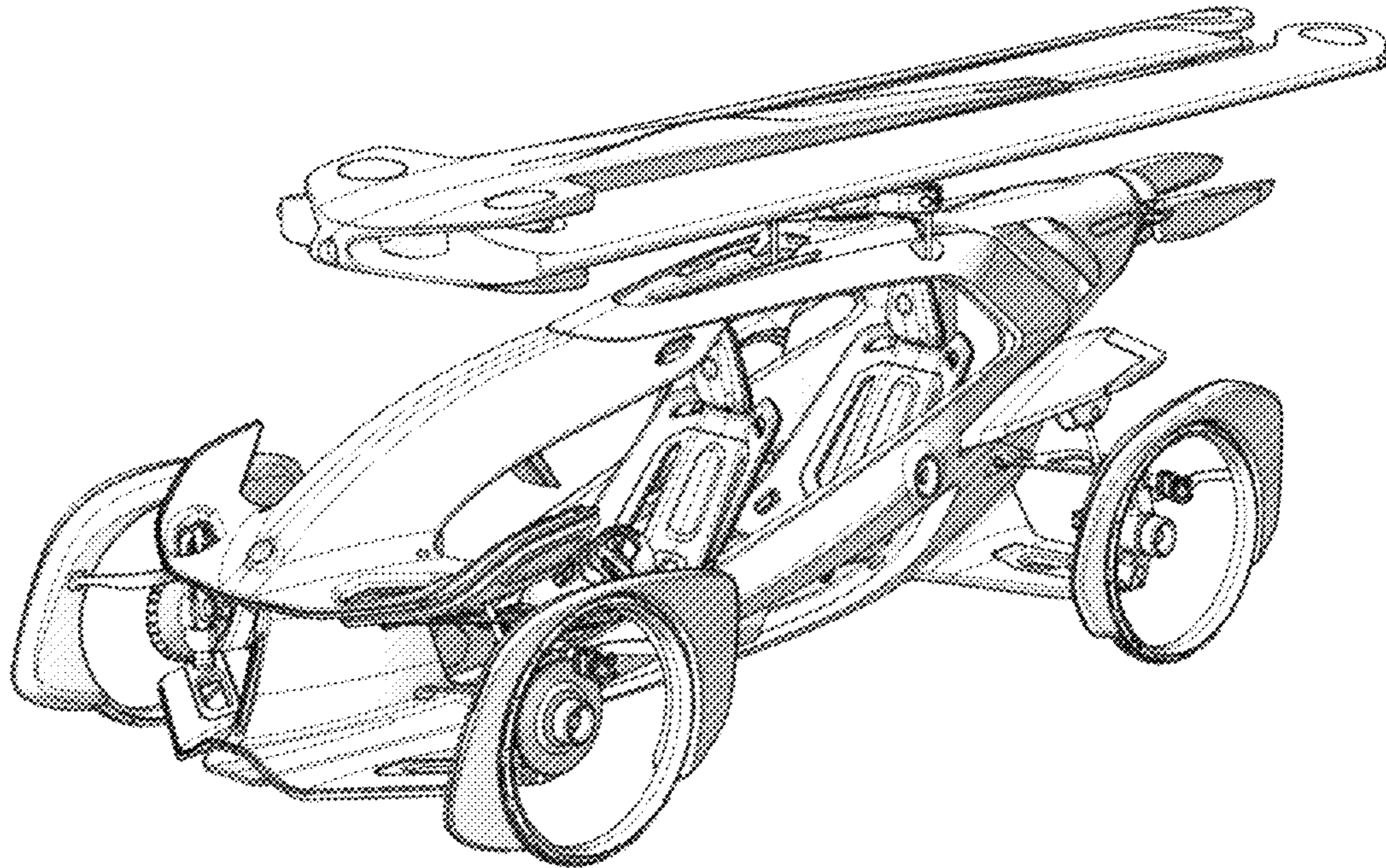

2.2

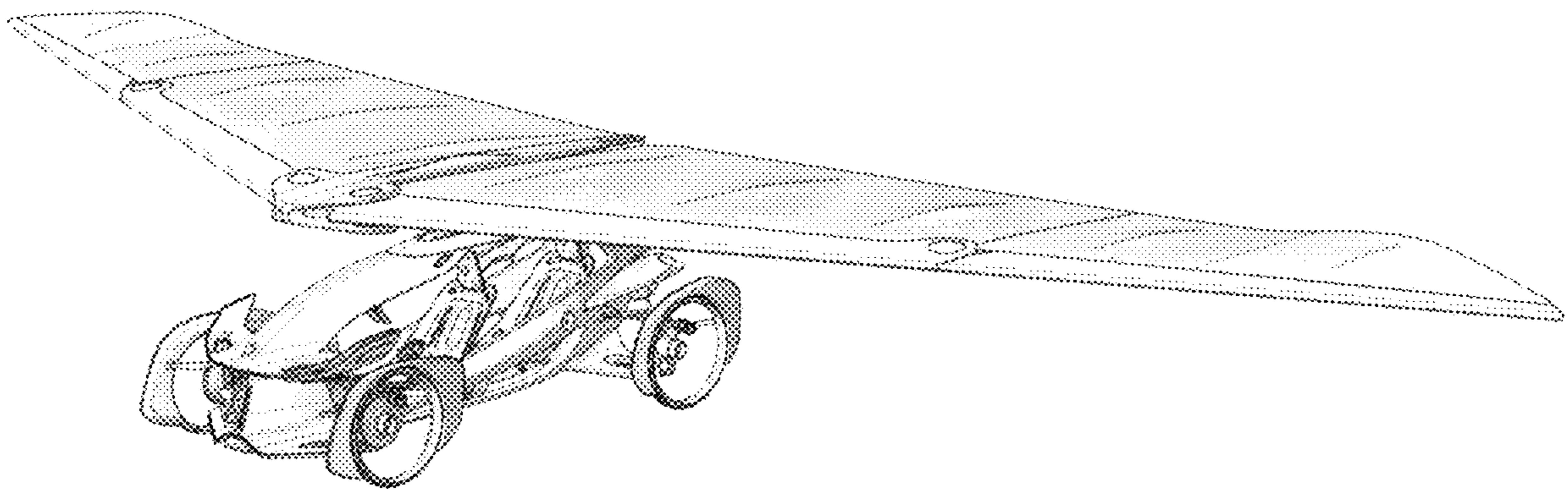



2.3

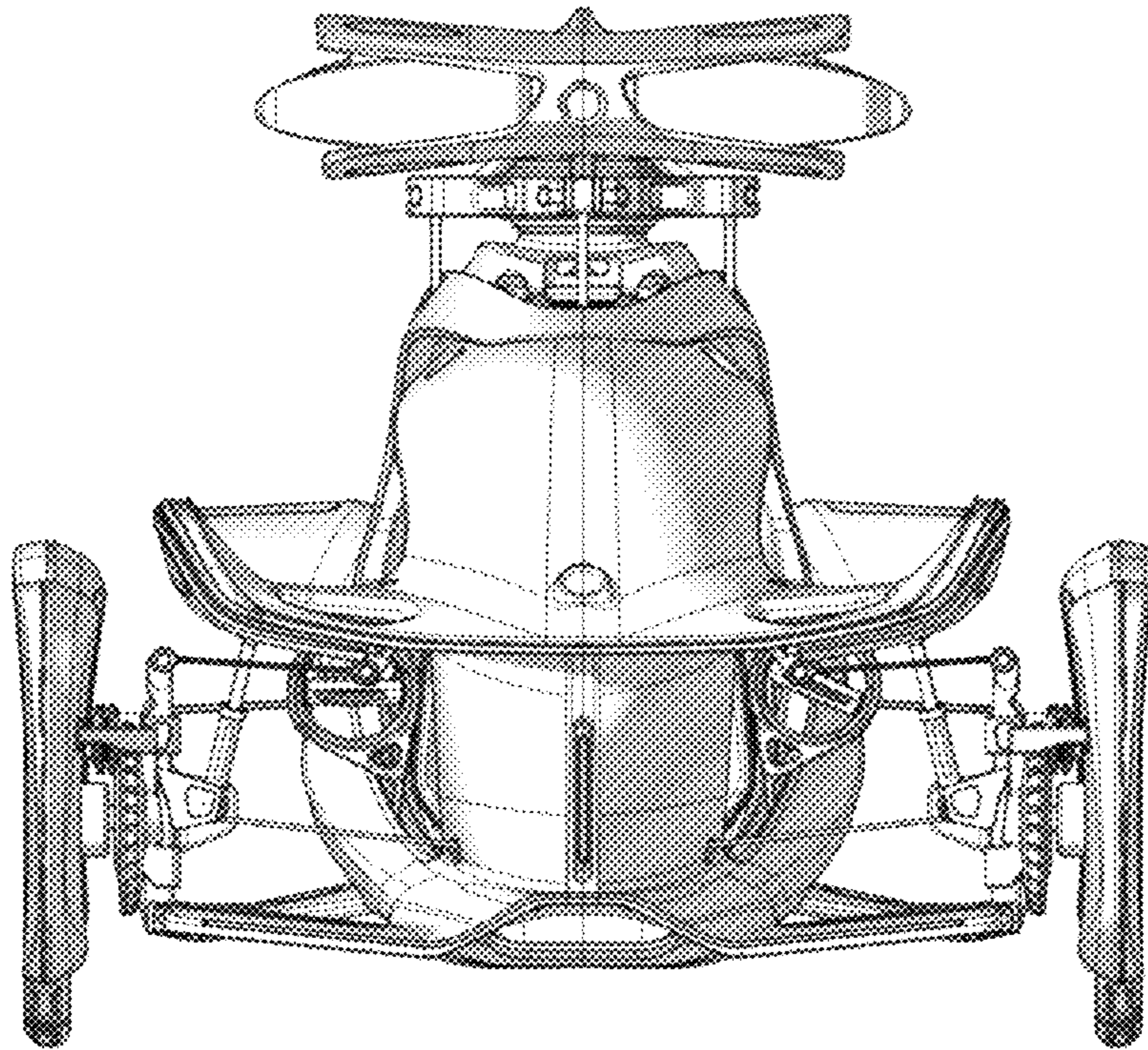



2.4

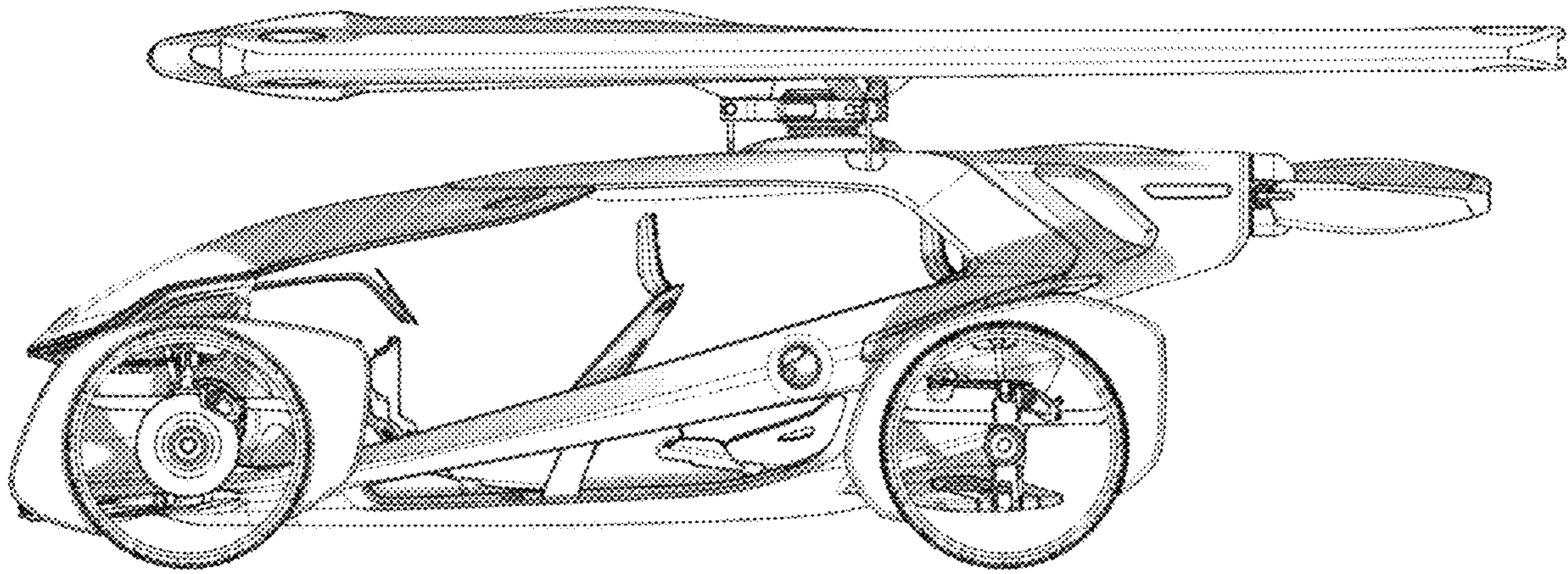

2.5

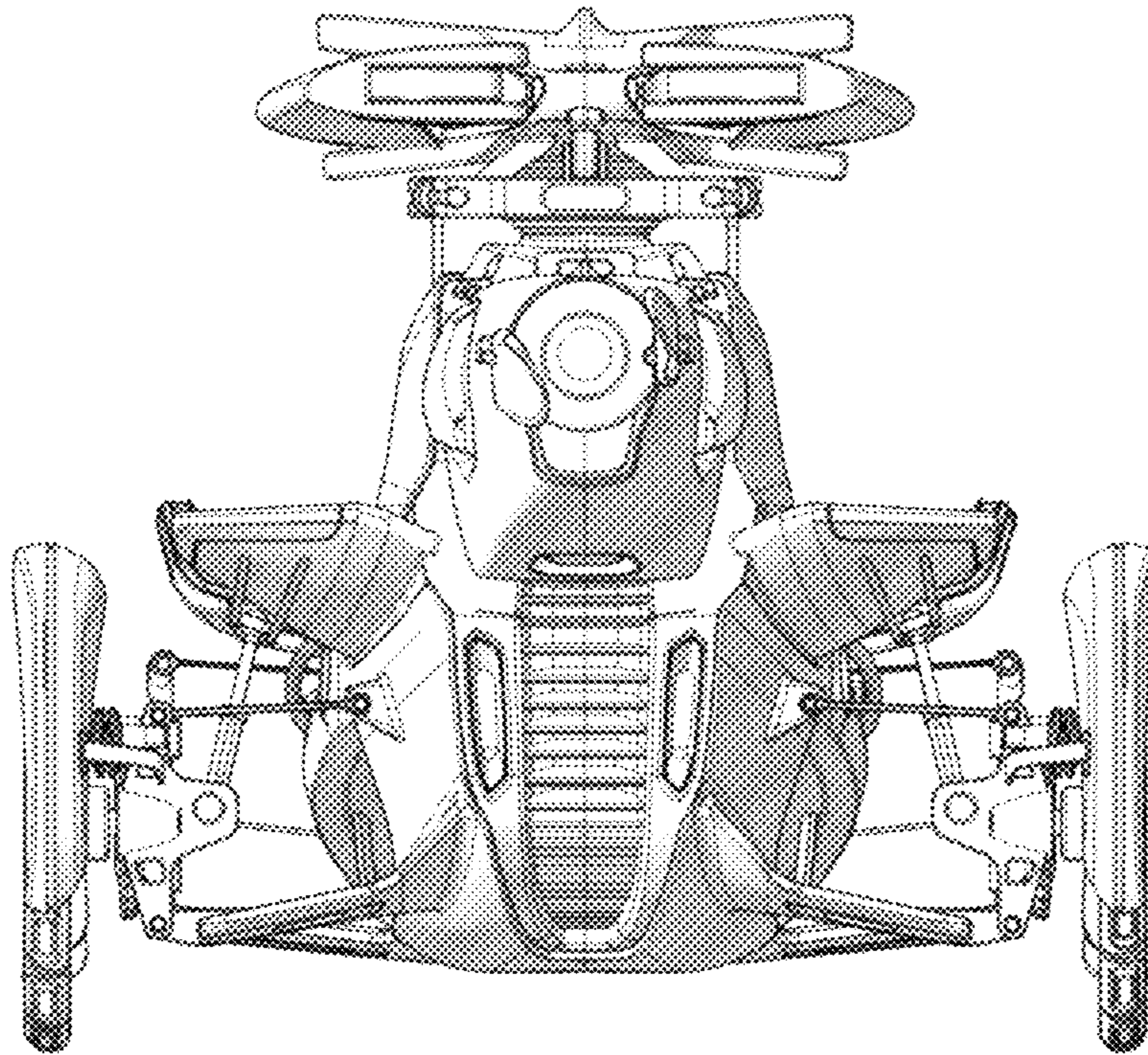

2.6

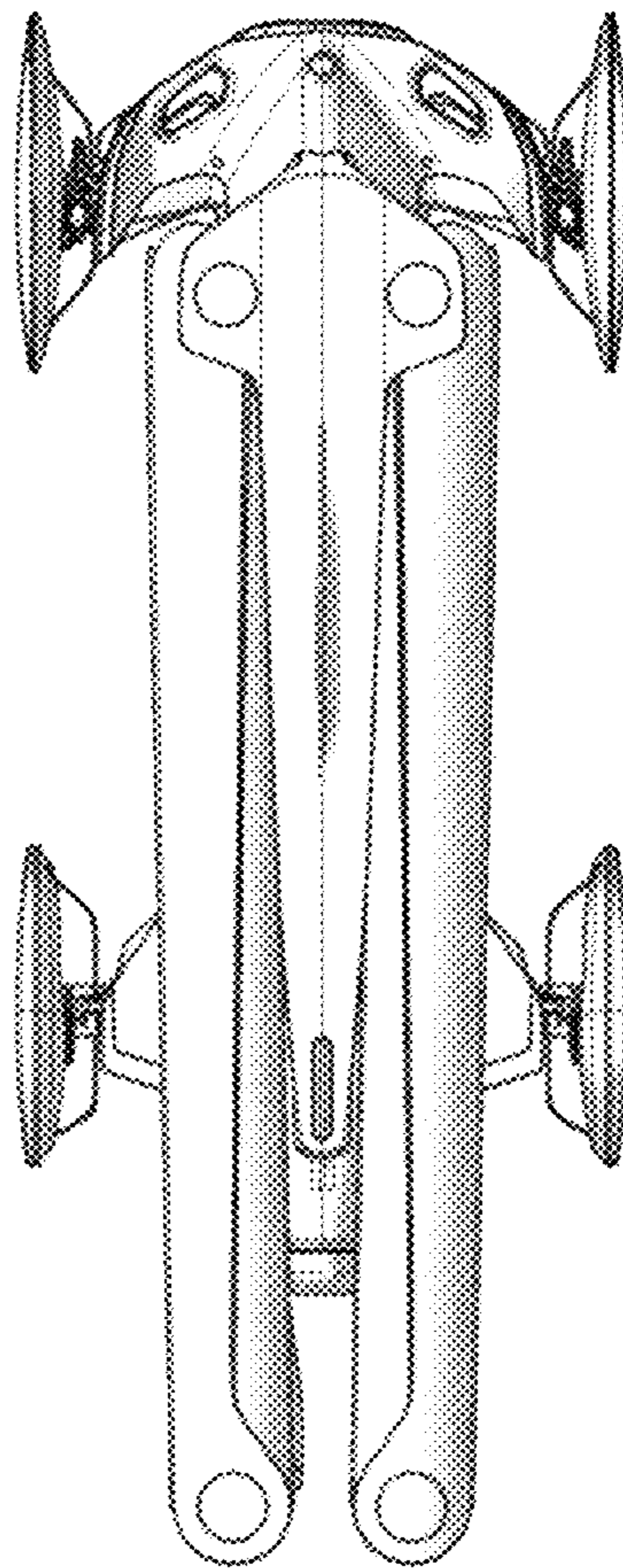

2.7

