



US00D880304S

(12) **United States Design Patent**  
**Melkonian**

(10) **Patent No.:** **US D880,304 S**

(45) **Date of Patent:** **\*\* Apr. 7, 2020**

(54) **HEX BOTTLE**

(71) Applicant: **DOWN TOWN WHOLESALERS, INC.**, Vernon, CA (US)

(72) Inventor: **Arman Melkonian**, Granada Hills, CA (US)

(\*\*) Term: **15 Years**

(21) Appl. No.: **29/647,215**

(22) Filed: **May 10, 2018**

(51) **LOC (12) Cl.** ..... **09-01**

(52) **U.S. Cl.**  
USPC ..... **D9/531; D9/559**

(58) **Field of Classification Search**  
USPC ..... D9/434, 516, 522, 528, 530-531, D9/537-538, 540-541, 543, 548, 557, D9/559, 563, 570, 575, 715, 719; D7/509-511, 533, 536  
CPC ..... B65D 1/00; B65D 1/02; B65D 1/0223; B65D 1/0261; B65D 1/0284; B65D 1/44; B65D 23/00; B65D 23/10; B65D 23/102; B65D 2501/00; B65D 2501/0009; B65D 2501/081; A45F 3/16; A45F 3/18  
See application file for complete search history.

(56) **References Cited**

**U.S. PATENT DOCUMENTS**

D320,344 S \* 10/1991 Larson ..... D9/520  
5,133,469 A 7/1992 Mehta

D339,067 S	9/1993	Rokus	
D397,942 S *	9/1998	Lewis	D9/531
D419,885 S	2/2000	Gonzalez C.	
D474,692 S	5/2003	Yu	
6,910,596 B2	6/2005	Herckner	
D531,512 S	11/2006	Yu	
D605,946 S *	12/2009	Manderfield, Jr.	D9/531
D646,045 S *	9/2011	Stamper	D99/35
D651,854 S *	1/2012	Cabados	D7/510
D726,018 S *	4/2015	Archer	D9/446
D816,410 S *	5/2018	Yu	D7/510
D830,180 S *	10/2018	Melkonian	D9/531
D838,598 S *	1/2019	Melkonian	D9/531

\* cited by examiner

*Primary Examiner* — Dana Meyrow

(74) *Attorney, Agent, or Firm* — Foundation Law Group; Sevag Demirjian

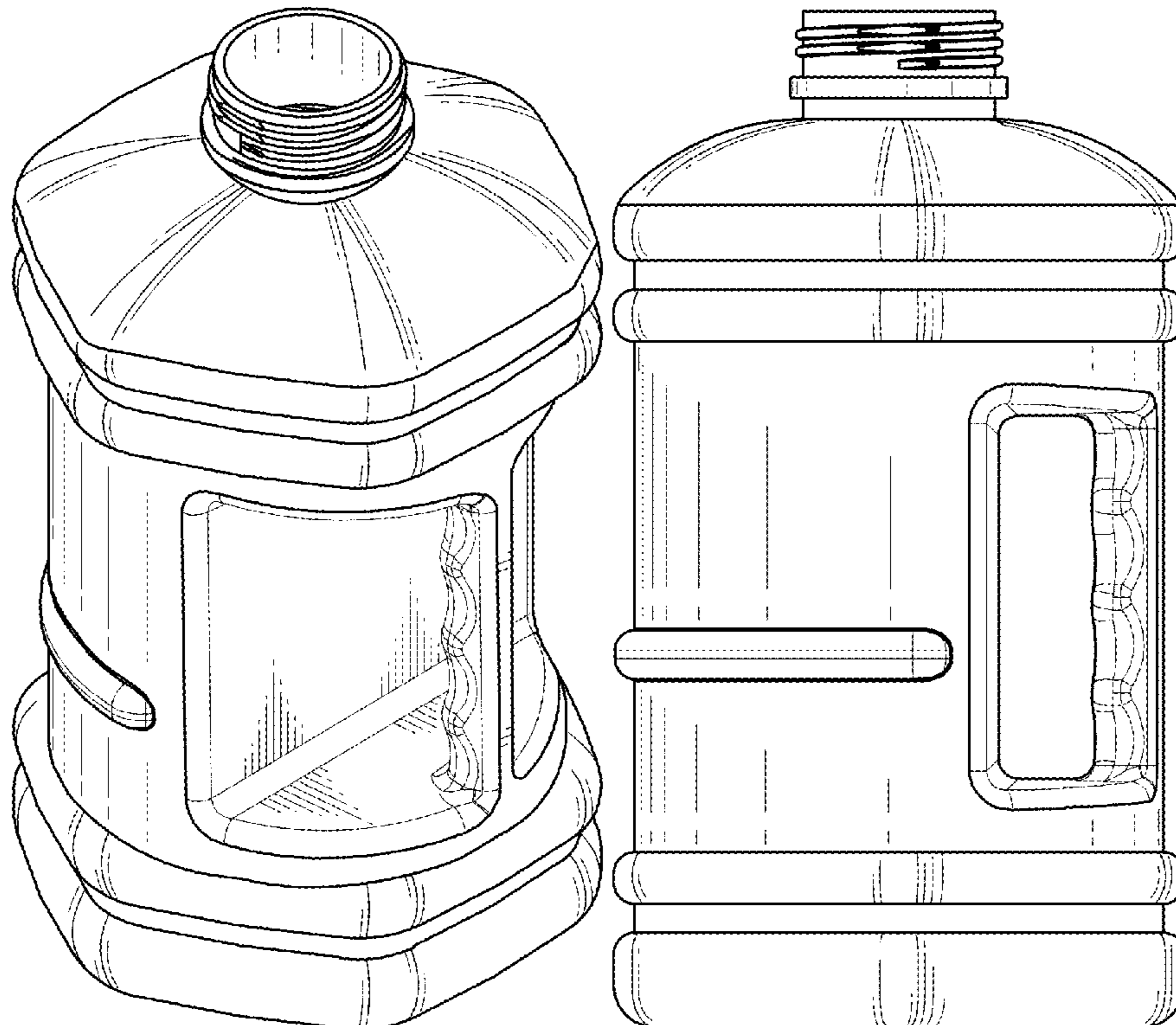
(57) **CLAIM**

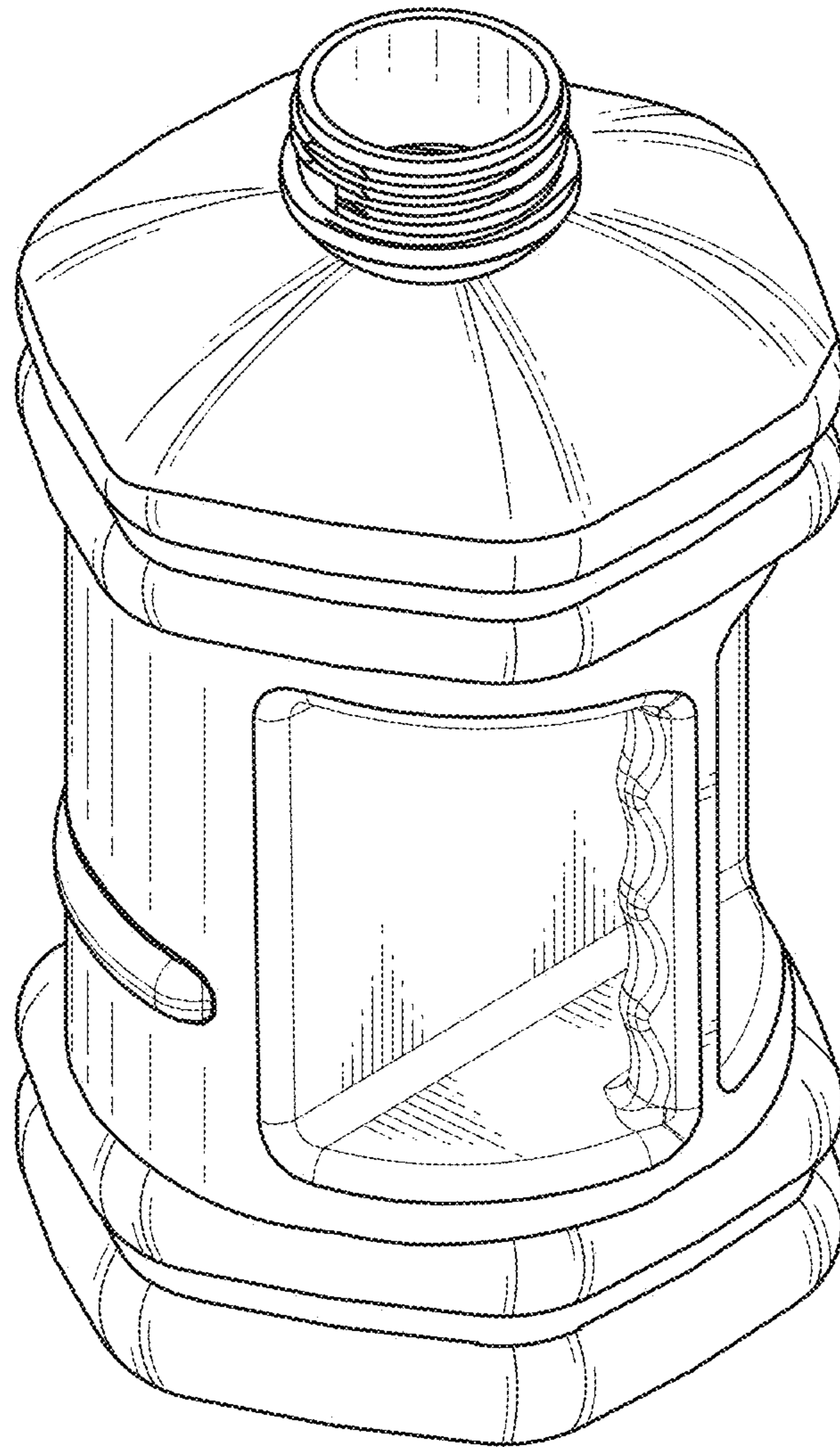
The ornamental design for a hex bottle, as shown and described.

**DESCRIPTION**

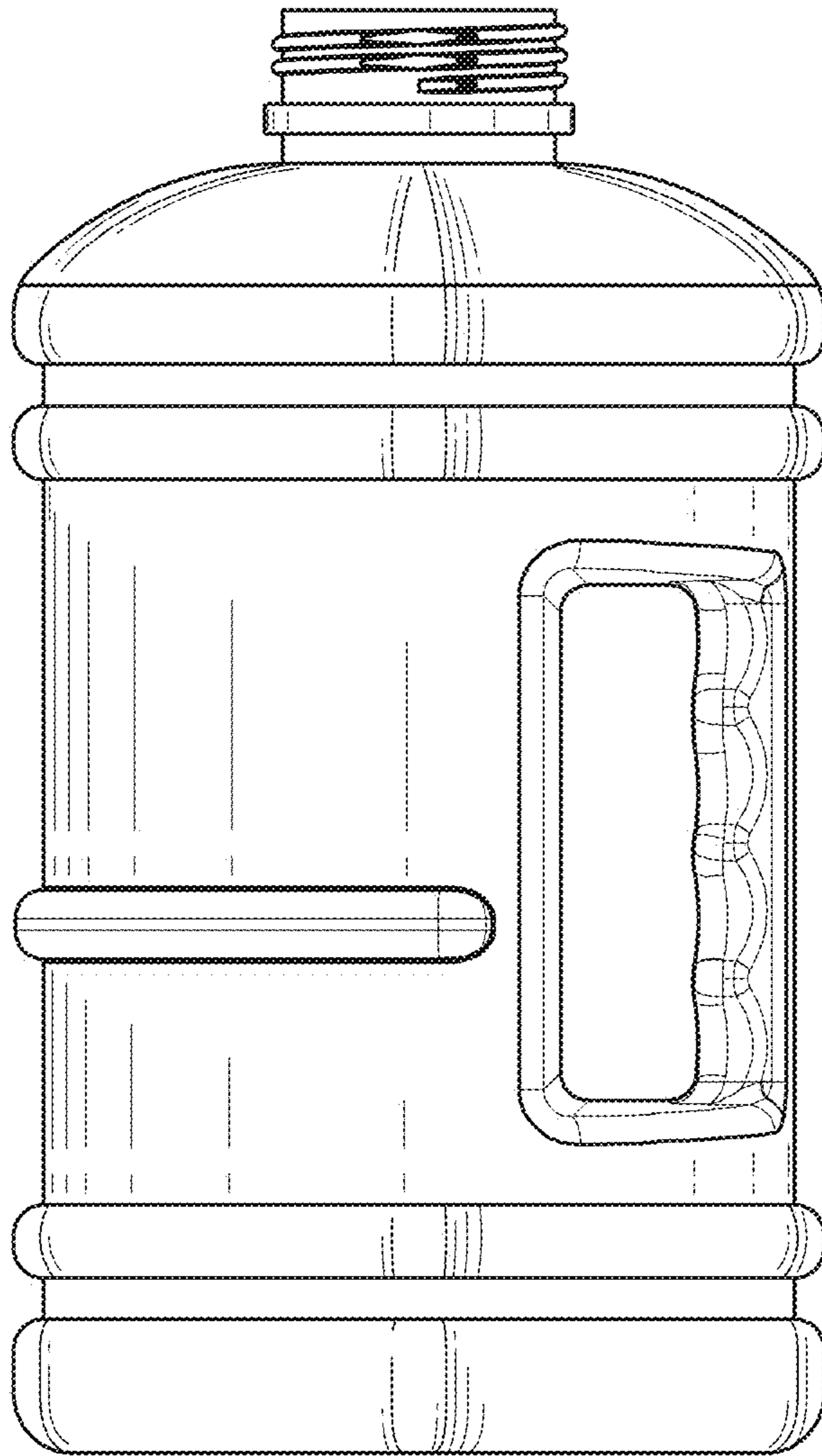
FIG. 1—Top, front, left side perspective view of a hex bottle, showing my new design;  
FIG. 2—Left side elevation view, the right side elevation view being a mirror image  
FIG. 3—Rear elevation view; and,  
FIG. 4—Top plan view.  
The broken lines shown are included for the purpose of illustrating the unclaimed portions of the bottle and form no part of the claim.

**1 Claim, 4 Drawing Sheets**

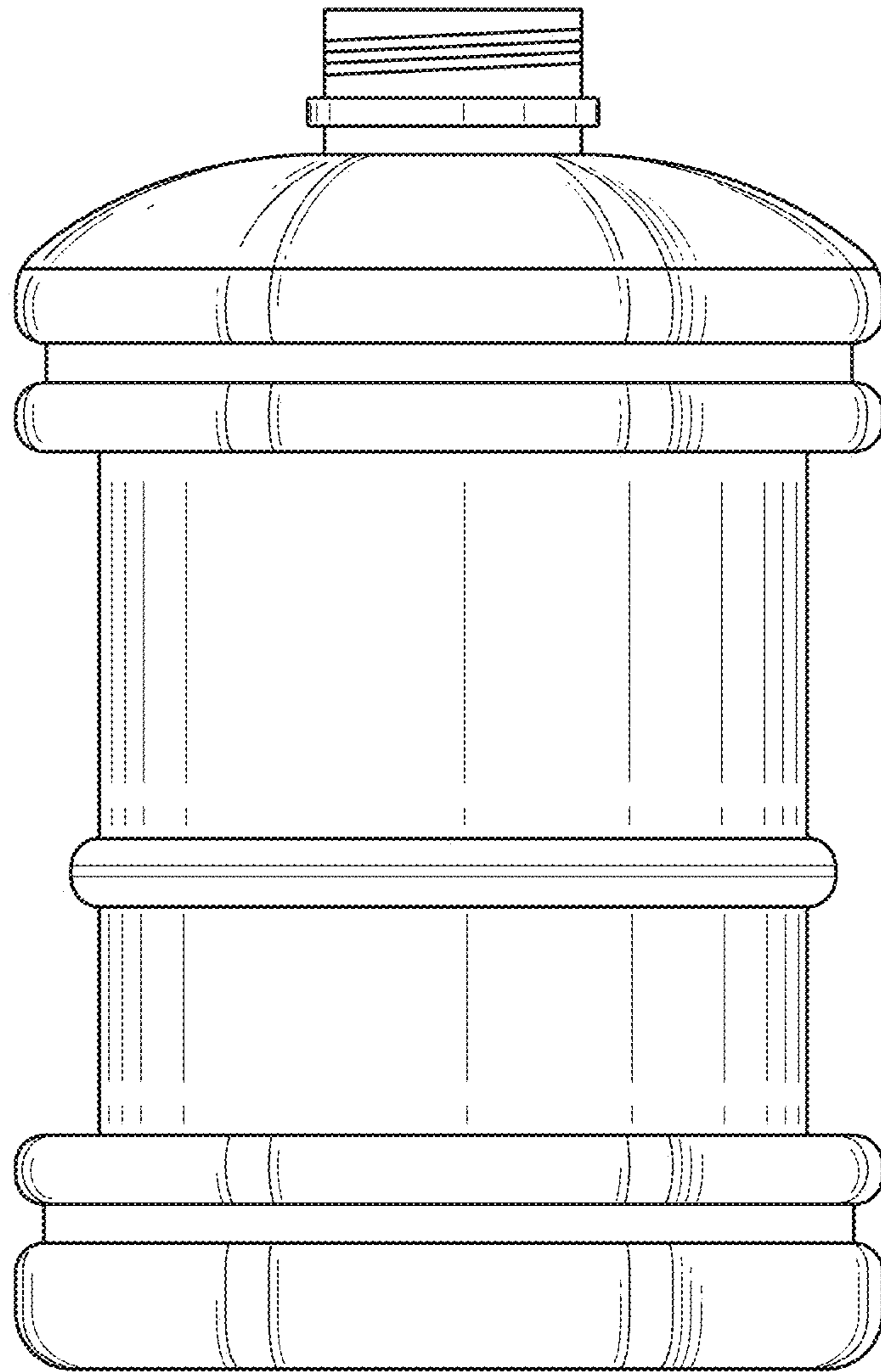




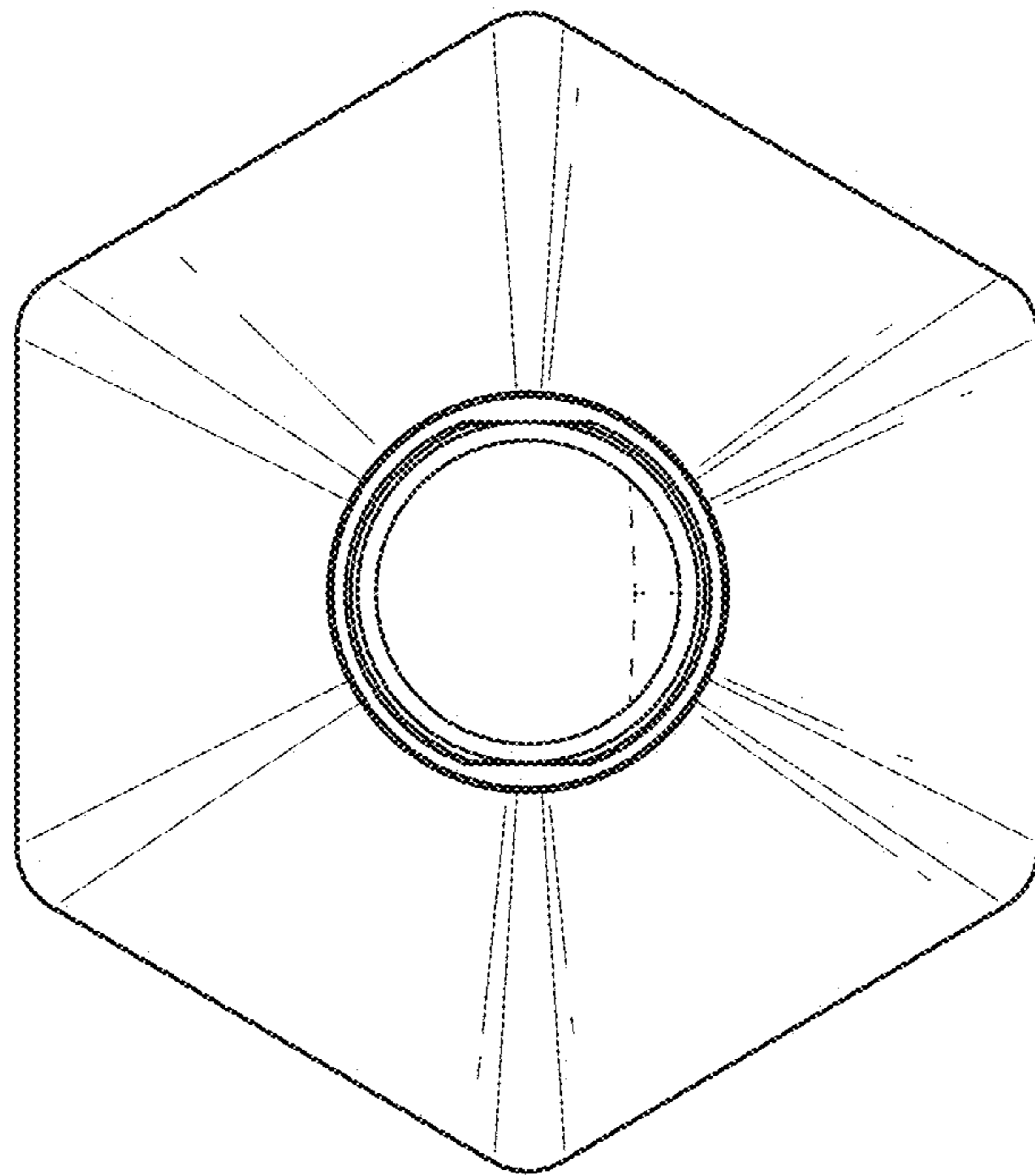
*FIG. 1*



*FIG. 2*



*FIG. 3*



*FIG. 4*