



US00D880024S

(12) **United States Design Patent**
Liu

(10) **Patent No.:** **US D880,024 S**
(45) **Date of Patent:** **** Mar. 31, 2020**

(54) **VEHICLE LIGHT**

(71) Applicant: **Zongxian Liu**, Chino, CA (US)

(72) Inventor: **Zongxian Liu**, Chino, CA (US)

(**) Term: **15 Years**

(21) Appl. No.: **29/628,385**

(22) Filed: **Dec. 4, 2017**

(51) **LOC (12) Cl.** **26-06**

(52) **U.S. Cl.**
USPC **D26/28**

(58) **Field of Classification Search**

USPC D12/86, 90-92, 114, 163, 169, 171-173,
D12/181, 190, 196, 197, 199, 400;
D17/1, 222; D26/28-36, 139
CPC .. B62J 6/02; B62J 6/00; B60Q 3/0279; B60Q
3/104; B60Q 3/10408; B60Q 3/10466;
B60Q 3/12653; B60Q 3/128; F21S 48/00;
F21S 48/10; F21S 48/115; F21S 48/225;
F21S 48/1233; F21S 48/1266; F21S
48/1388; F21S 48/2268; F21V 21/04

See application file for complete search history.

(56) **References Cited**

U.S. PATENT DOCUMENTS

D586,020 S *	2/2009	Hsu	D26/28
D746,493 S *	12/2015	Watanuki	D26/28
D755,421 S *	5/2016	Aleman	D26/28
D791,988 S *	7/2017	Lin	D26/28
D812,270 S *	3/2018	Minamiyama	D26/28
D839,461 S *	1/2019	Hegge	D26/28
D851,298 S *	6/2019	Hewitt	D26/28

OTHER PUBLICATIONS

Carousell | Marquee Light Lightning Bolt, last updated on Oct. 3, 2015, © 2019 Carousell [online], [site visited Jun. 23, 2019].

Available from Internet, <URL: <https://sg.carousell.com/p/marquee-light-lightning-bolt-29937102/>>.*

* cited by examiner

Primary Examiner — Philip S Hyder
Assistant Examiner — Cary M Robinson

(74) *Attorney, Agent, or Firm* — Tommy S F Wang;
Wang IP Law Group, P.C.

(57) **CLAIM**

The ornamental design for a vehicle light, as shown and described.

DESCRIPTION

FIG. 1 is a perspective view of a vehicle light showing my new design;
FIG. 2 is a front view thereof;
FIG. 3 is a rear view thereof;
FIG. 4 is a left side view thereof;
FIG. 5 is a right side view thereof;
FIG. 6 is a top view thereof;
FIG. 7 is a bottom view thereof; and,
FIG. 8 is another perspective view thereof with a cable coupled to the vehicle light.
The broken lines in FIGS. 1-8 illustrate portions of the vehicle light in which the design is embodied that form no part of the claimed design, The broken lines of the cable in FIG. 8 illustrate the environment of the claimed design, the dash-dot-dot-dash broken lines FIG. 8 illustrate the omission of the cable. None of the broken lines form part of the claimed design.

1 Claim, 5 Drawing Sheets

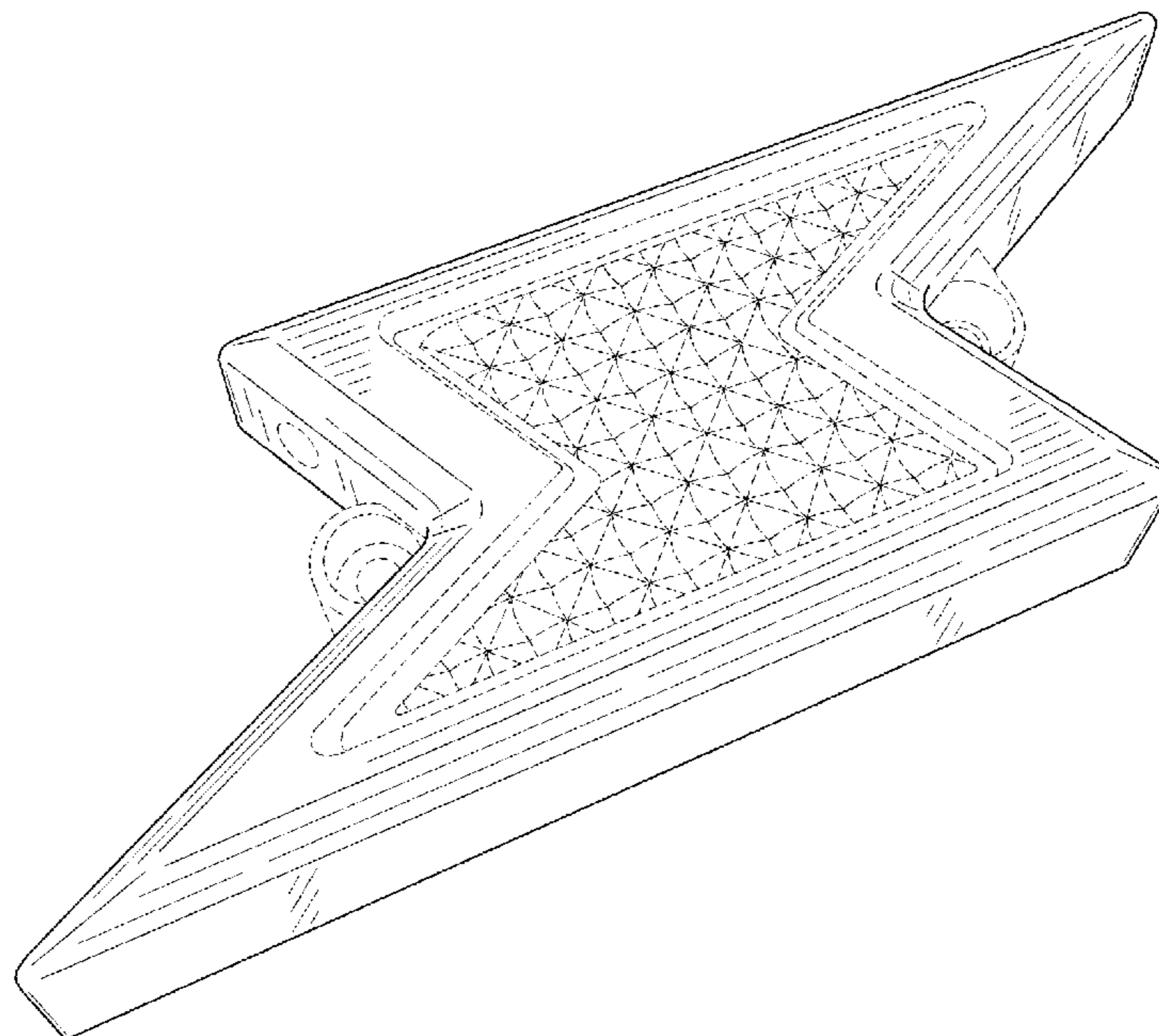

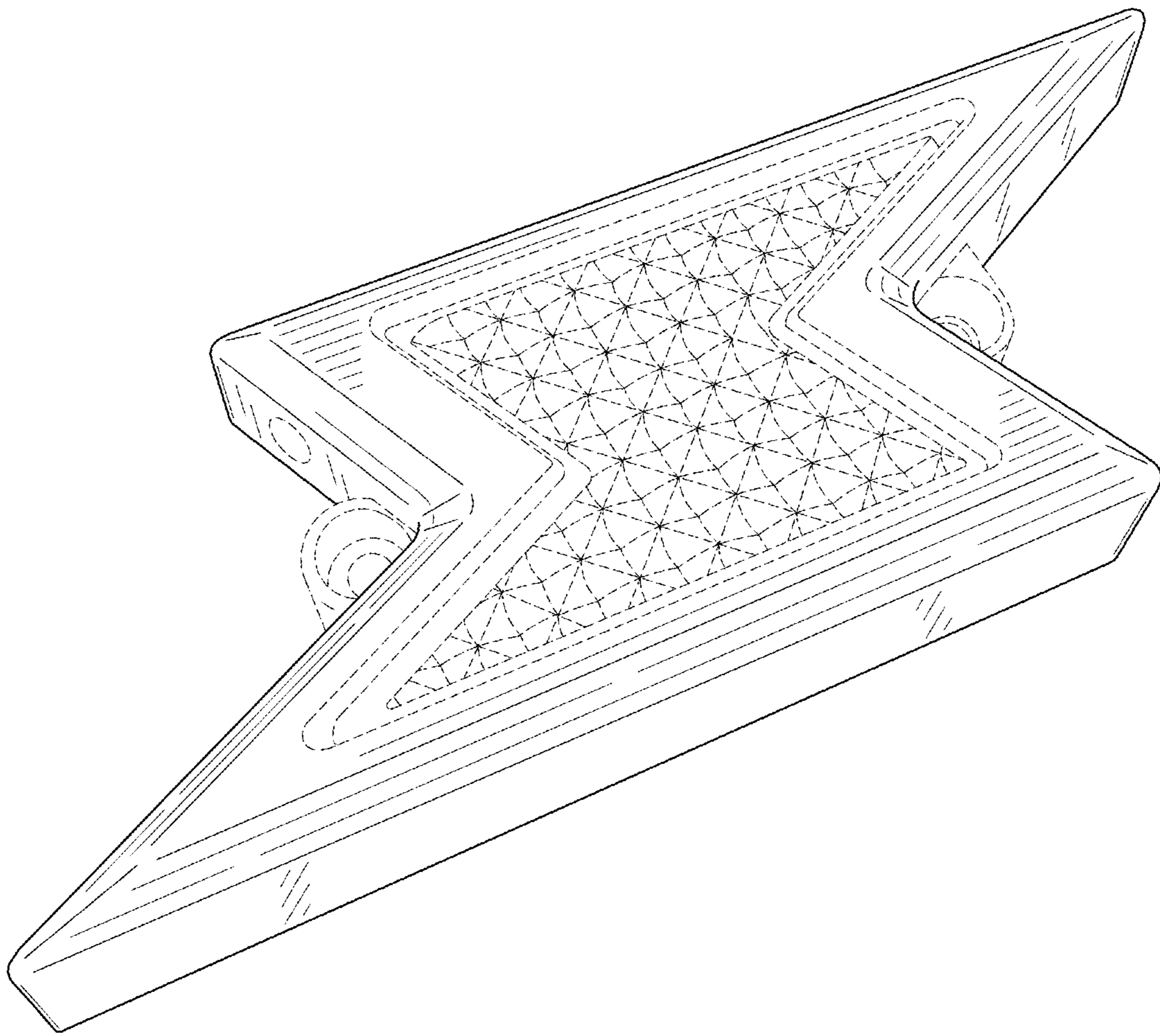

FIG. 1

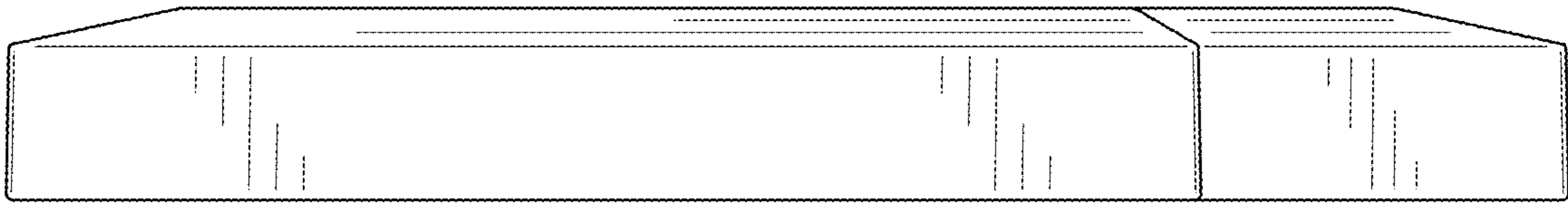

FIG. 2

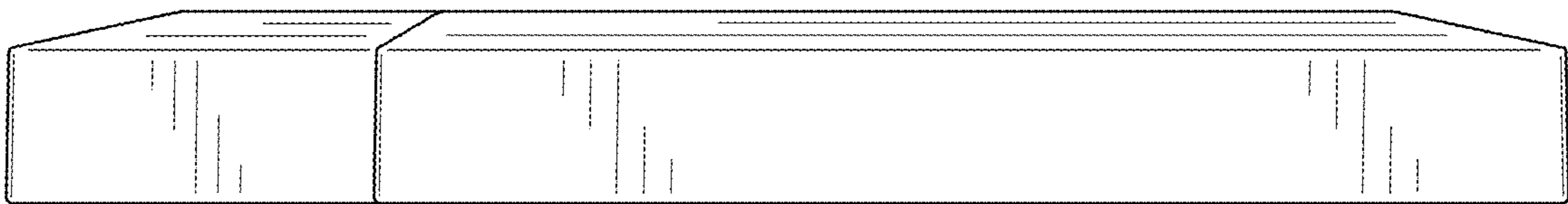

FIG. 3

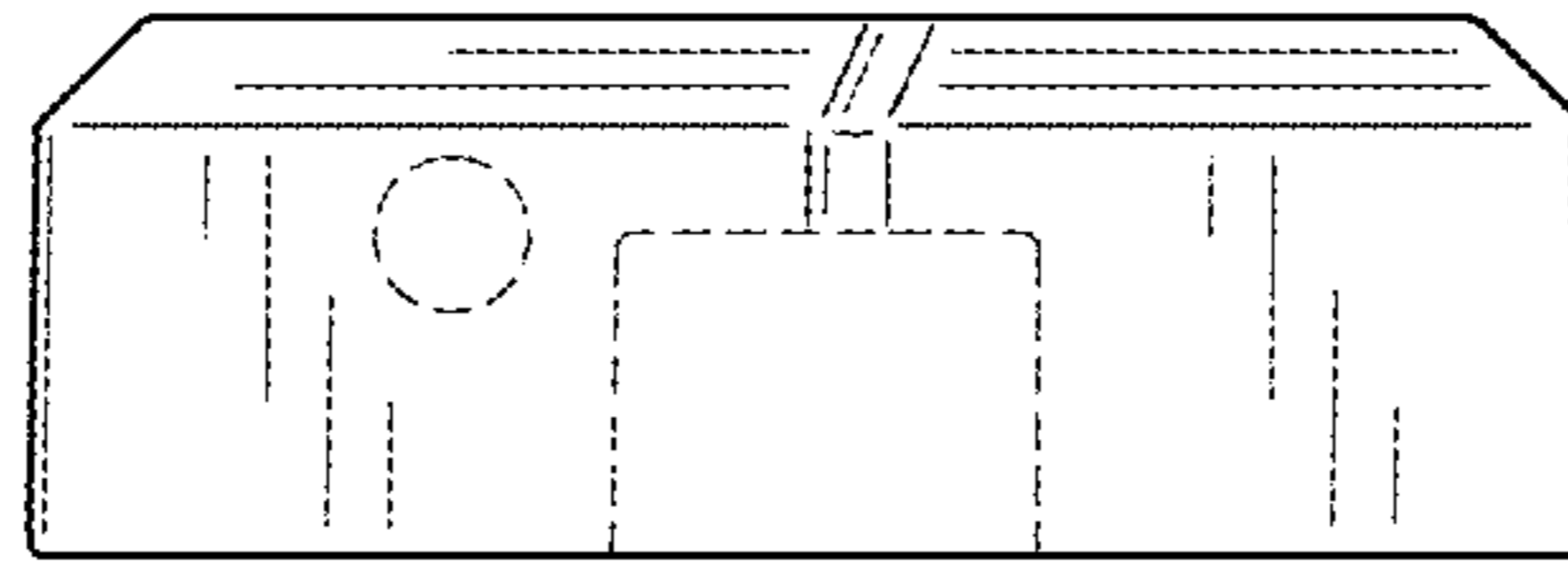

FIG. 4

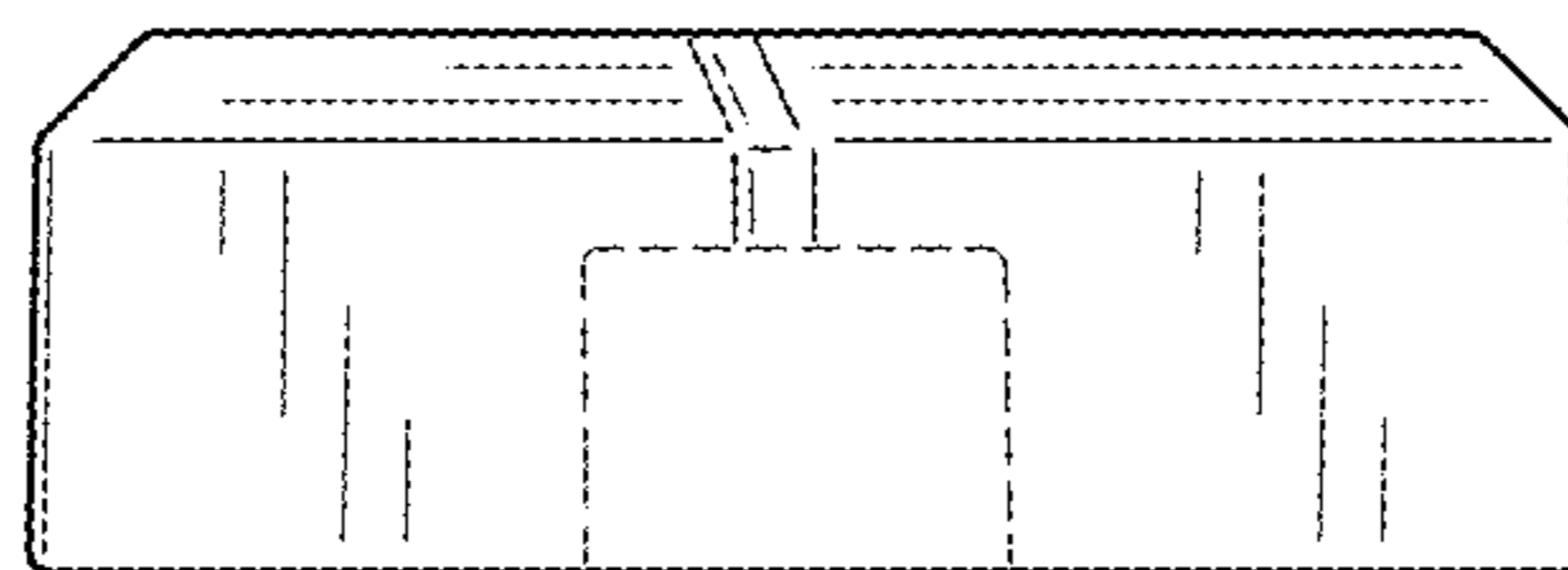

FIG. 5

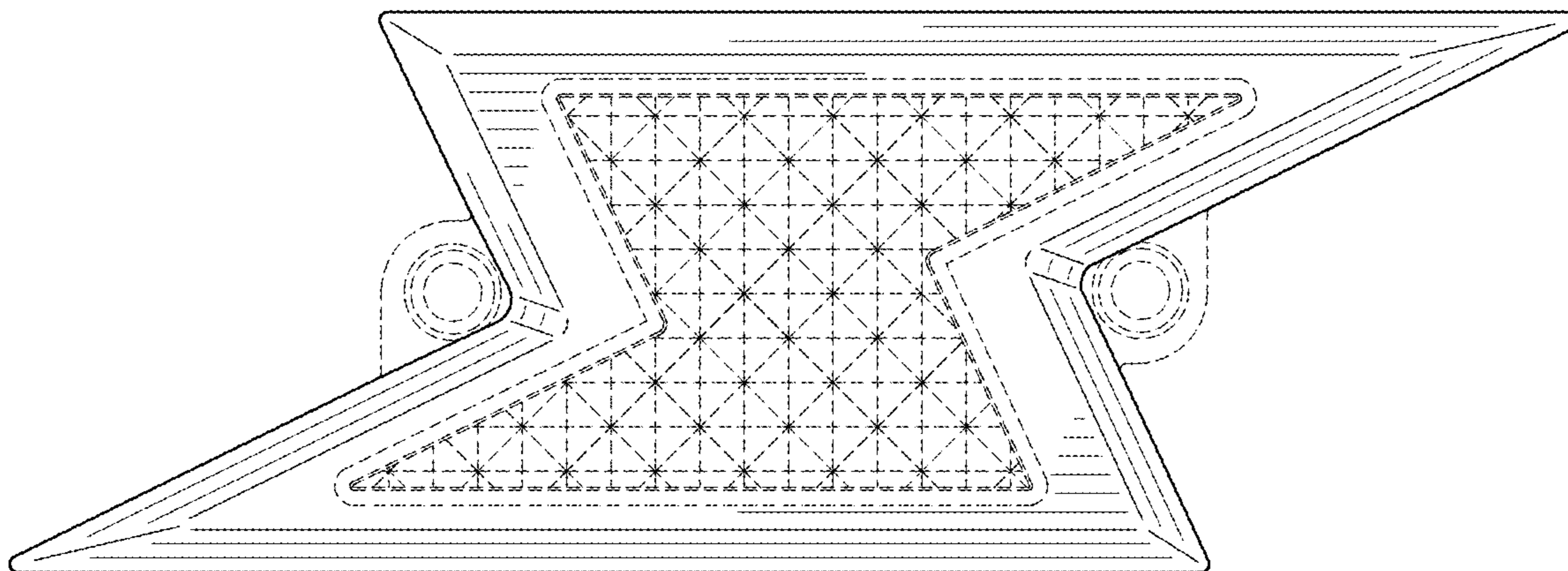

FIG. 6

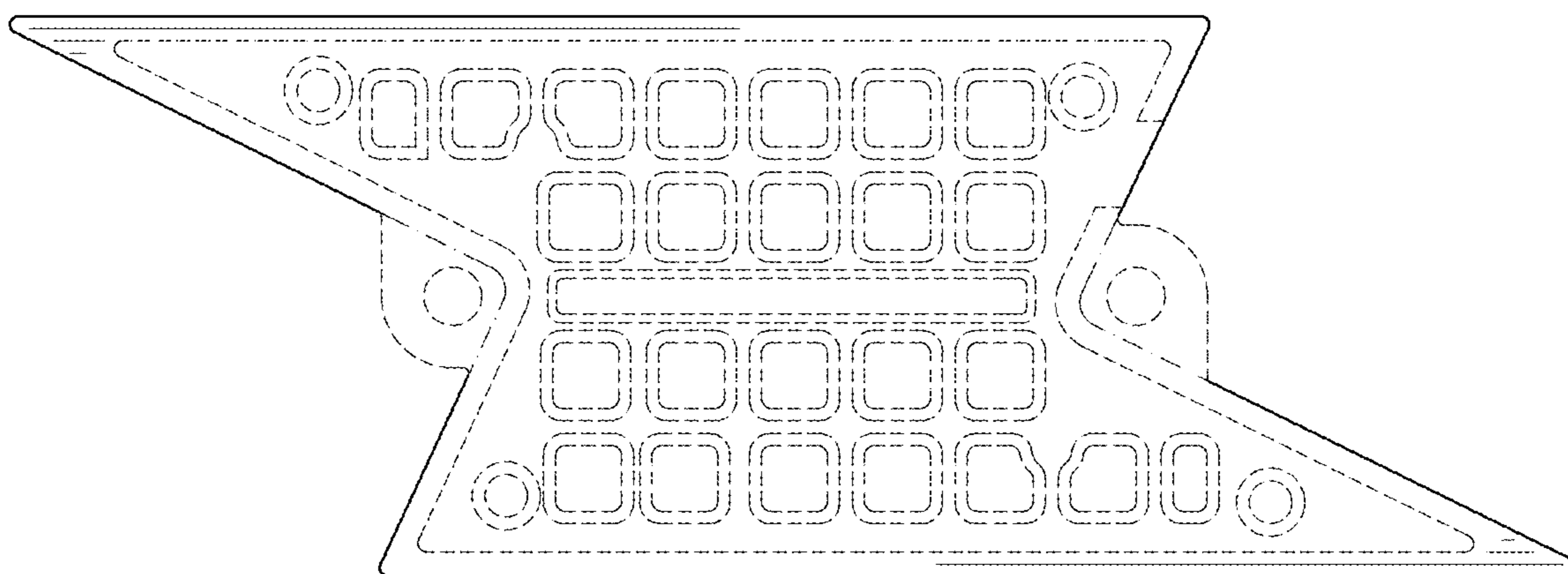

FIG. 7

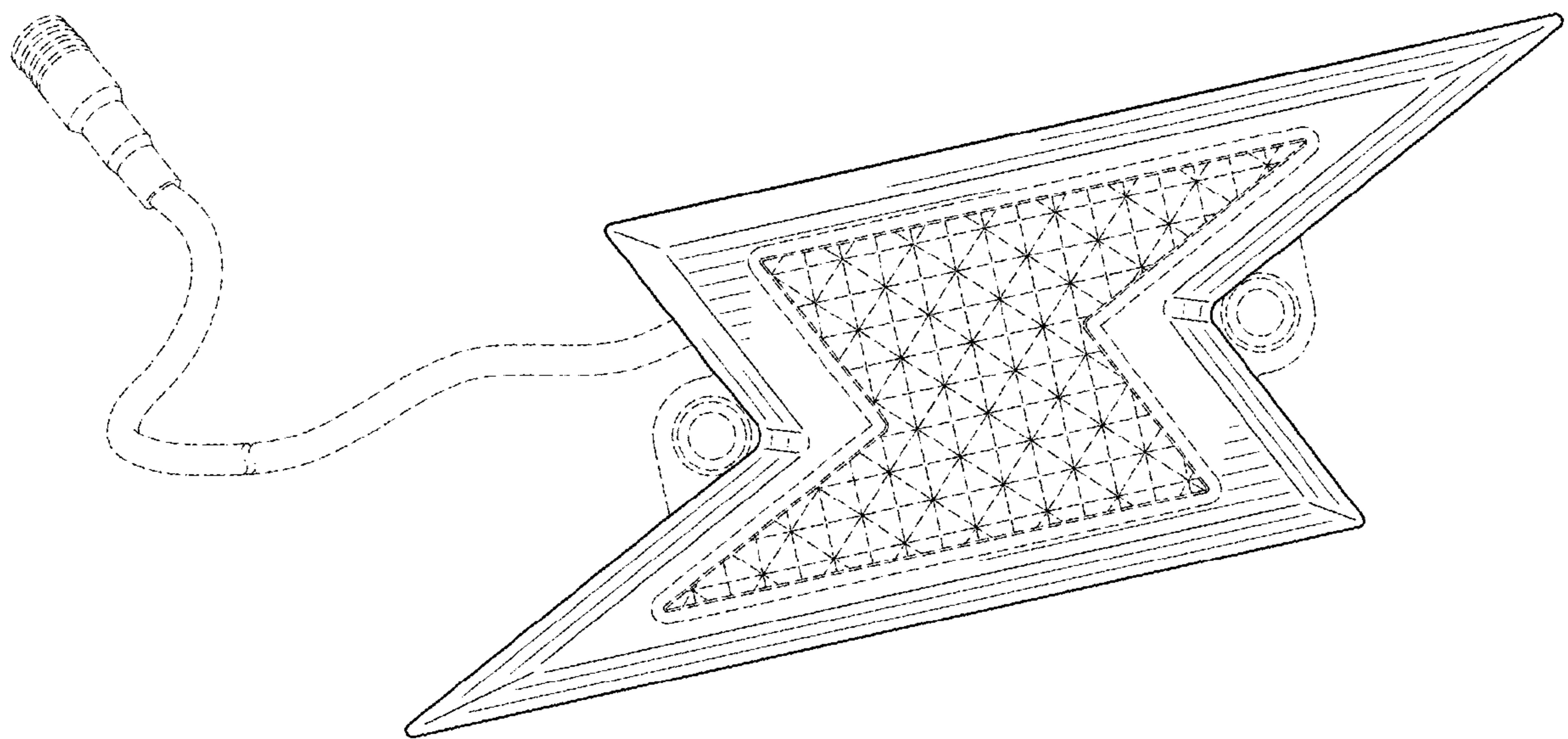

FIG. 8