



US00D879879S

(12) **United States Design Patent**  
**Morgan**

(10) **Patent No.:** **US D879,879 S**  
(45) **Date of Patent:** **\*\* Mar. 31, 2020**

(54) **LIGHTED VEHICLE ADVERTISING SYSTEM**

(71) Applicant: **Russ Bryan Morgan**, Weston, FL (US)

(72) Inventor: **Russ Bryan Morgan**, Weston, FL (US)

(\*\*) Term: **15 Years**

(21) Appl. No.: **29/626,853**

(22) Filed: **Nov. 21, 2017**

(51) **LOC (12) Cl.** ..... **19-08**

(52) **U.S. Cl.**  
USPC ..... **D20/22**; D12/193

(58) **Field of Classification Search**  
USPC ..... D6/511, 592, 613; D8/354; D9/457;  
D11/165, 172; D12/193; D14/374;  
D19/1, 6, 9, 10; D20/10-15, 17-19, 22,  
D20/23, 27, 35, 40, 42, 99; D25/119;  
40/5, 124.01-124.09, 124.11-124.19,  
40/124.191, 200-211, 299.01, 305, 310,  
40/312, 360, 446, 541, 584, 638; 283/56,  
283/67, 71, 81; 362/812  
CPC . B60R 13/105; G09F 1/04; G09F 1/10; G09F  
1/103; G09F 1/12; G09F 1/14; G09F  
2001/106; G09F 3/18; G09F 3/185; G09F  
3/20; G09F 3/201; G09F 3/202; G09F  
3/204; G09F 7/10; G09F 7/18  
See application file for complete search history.

(56) **References Cited**

**U.S. PATENT DOCUMENTS**

D305,297 S *	1/1990	O'Neill	.....	D12/190
D310,775 S *	9/1990	Ruonala	.....	D8/377
5,579,599 A *	12/1996	Haeseler	.....	G09F 7/18
				248/156
D430,616 S *	9/2000	Rosenthal	.....	D20/22
D458,970 S *	6/2002	McCarthy	.....	D20/22
6,839,993 B1 *	1/2005	Piche	.....	G09F 3/207
				24/3.1
D604,151 S *	11/2009	Kollman	.....	D8/376

D613,921 S *	4/2010	Tsui	.....	D32/52
D634,787 S *	3/2011	Lerche	.....	D20/42
D761,682 S *	7/2016	Lowery	.....	D10/128
D766,731 S *	9/2016	Sekhon	.....	D9/415
D818,044 S *	5/2018	Hemphill	.....	D20/40
D829,533 S *	10/2018	Kanter	.....	D8/354
D833,648 S *	11/2018	Shearer	.....	D25/119
D833,851 S *	11/2018	Kanter	.....	D8/354
D846,370 S *	4/2019	Ni	.....	D8/354
D851,175 S *	6/2019	Warther	.....	D20/22
D854,090 S *	7/2019	Warther	.....	D20/22
10,388,190 B2 *	8/2019	Virmalo	.....	G09F 7/18
2005/0223610 A1 *	10/2005	Vogler	.....	G09F 1/10
				40/658

(Continued)

*Primary Examiner* — Cathron C Brooks

*Assistant Examiner* — Christian P. McLean

(74) *Attorney, Agent, or Firm* — Nancy J. Flint, Attorney At Law, P.A.; Nancy J. Flint, Esq.

(57) **CLAIM**

The ornamental design for a lighted vehicle advertising system, as shown and described.

**DESCRIPTION**

FIG. 1 is a perspective view of a lighted vehicle advertising system, showing the new design; FIG. 2 is an exploded view thereof; FIG. 3 is a front view thereof; FIG. 4 is a rear view thereof; FIG. 5 is a top view thereof; FIG. 6 is a bottom view thereof; FIG. 7 is a left side view thereof; FIG. 8 is a right side view thereof; and, FIG. 9 is a front view of the design of FIG. 3 shown in a non-claimed environment. The broken lines illustrate the environment of the design and form no part of the claim.

**1 Claim, 7 Drawing Sheets**

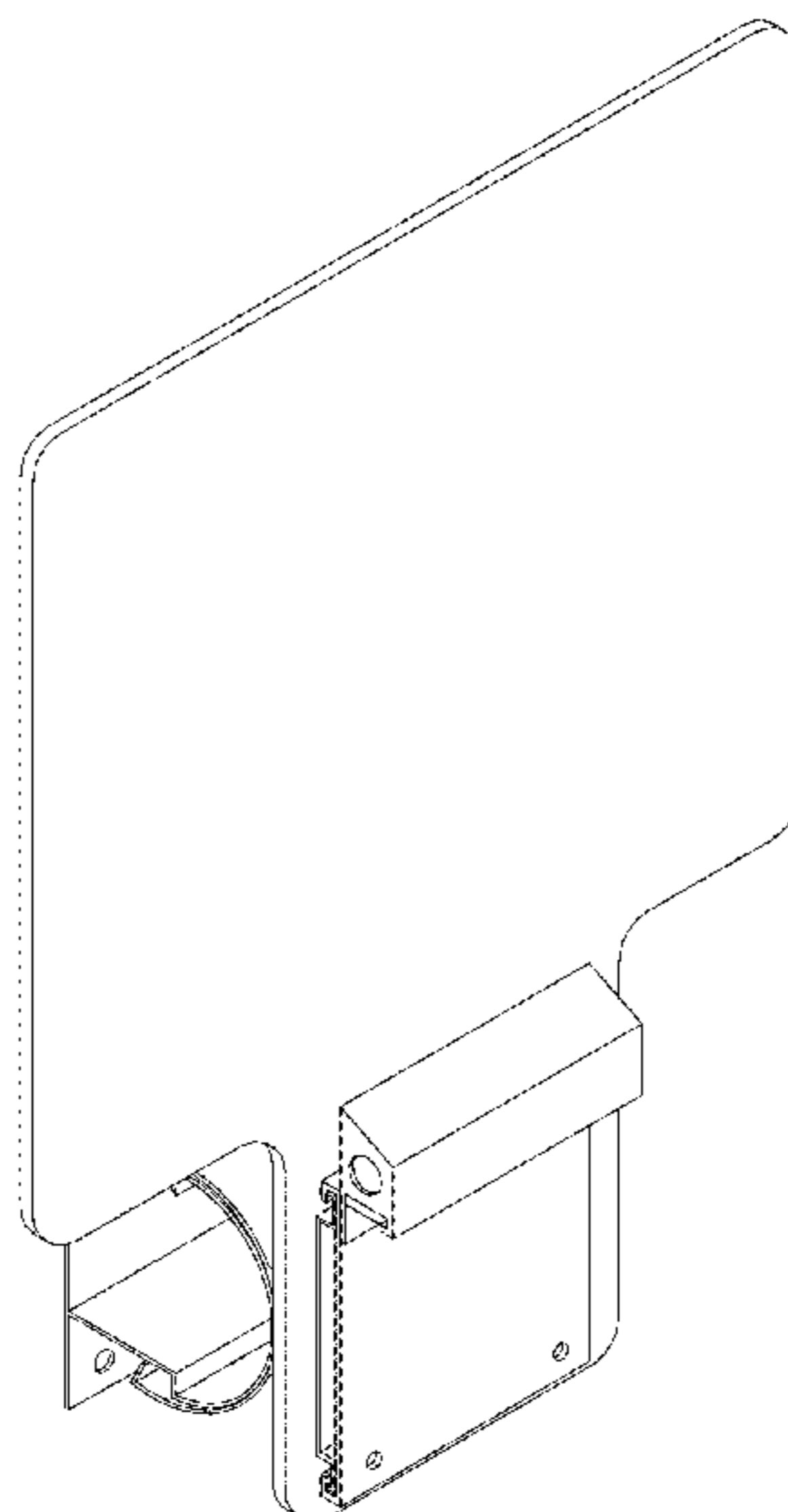

(56)

**References Cited**

U.S. PATENT DOCUMENTS

2010/0205841 A1\* 8/2010 Stancer, III ..... G09F 1/103  
40/607.14  
2019/0221141 A1\* 7/2019 Wilkinson, Jr. .... G09F 7/08  
2019/0248305 A1\* 8/2019 Diaz ..... B60R 13/105  
2019/0283686 A1\* 9/2019 Gussen ..... B60R 11/0229  
2019/0318667 A1\* 10/2019 Freeman ..... G09F 3/208

\* cited by examiner

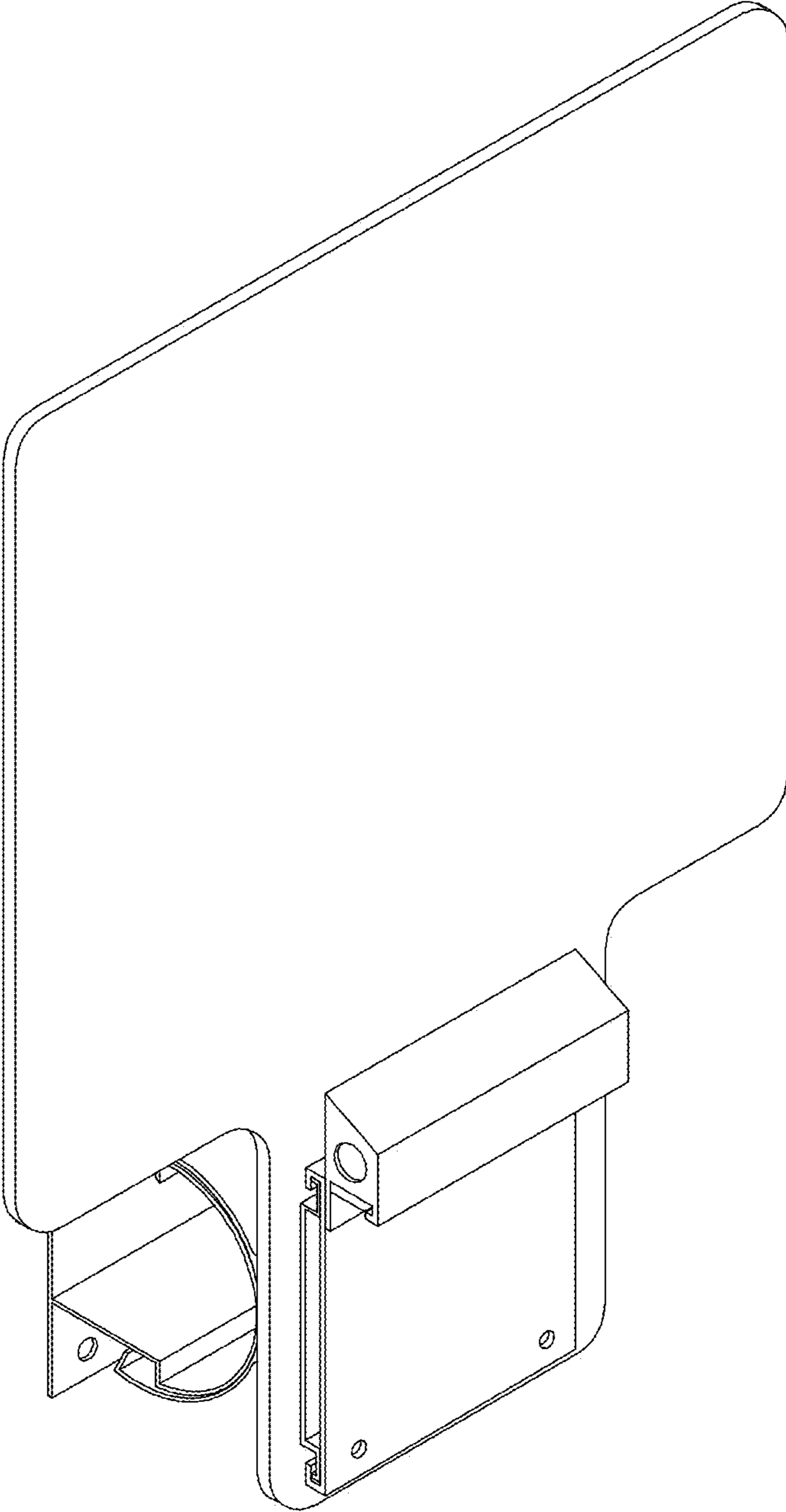
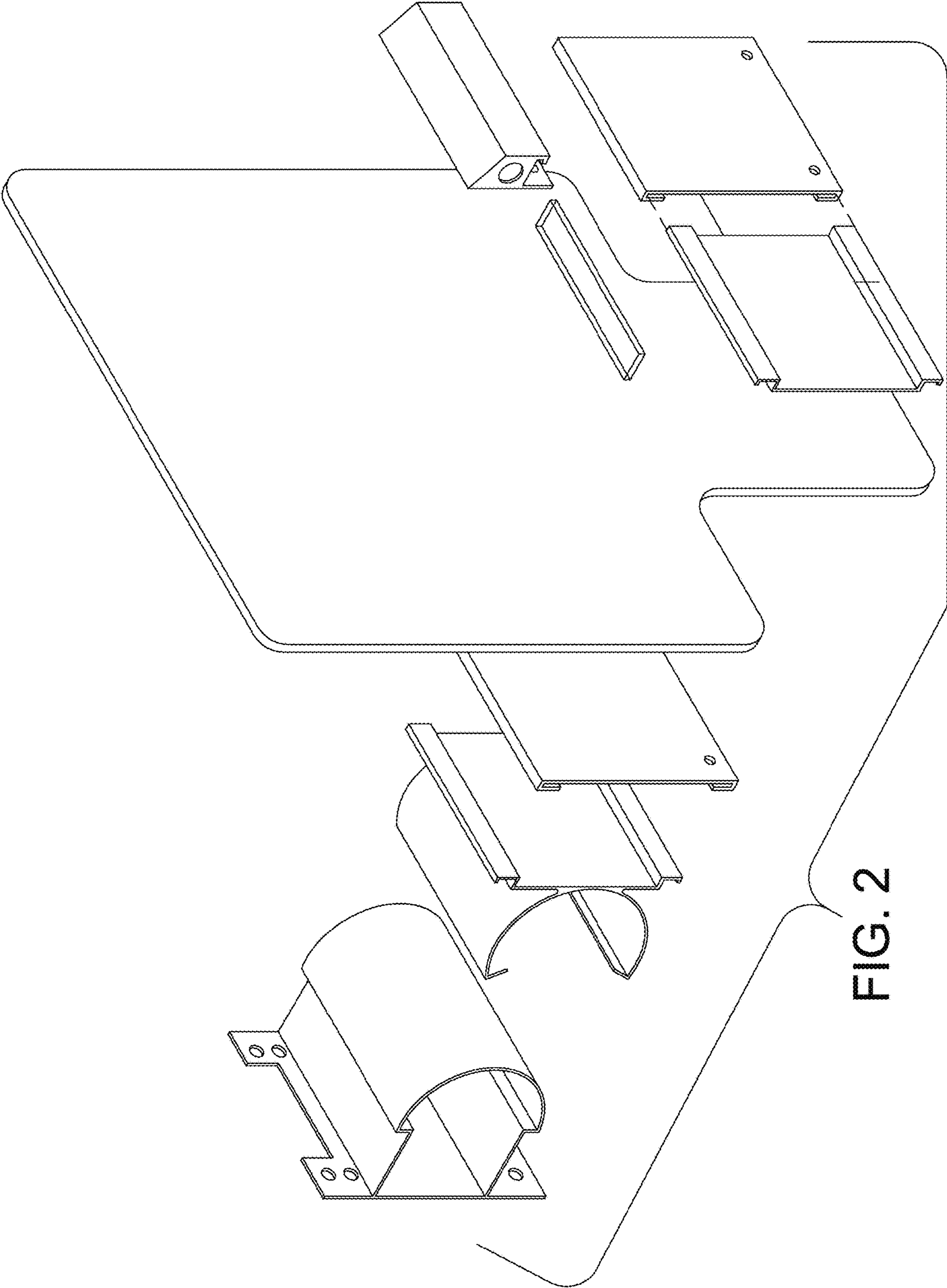

FIG. 1



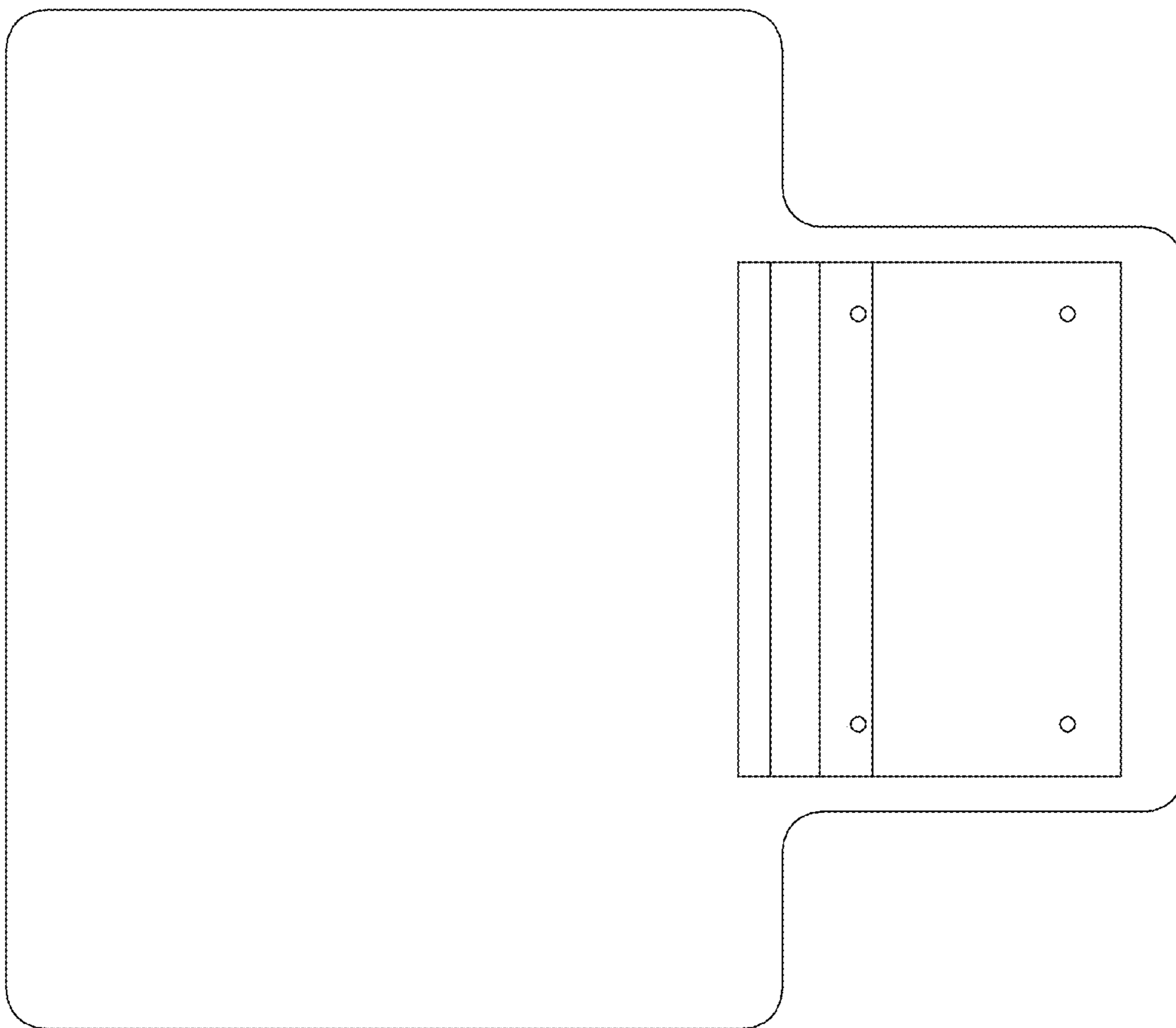

FIG. 3

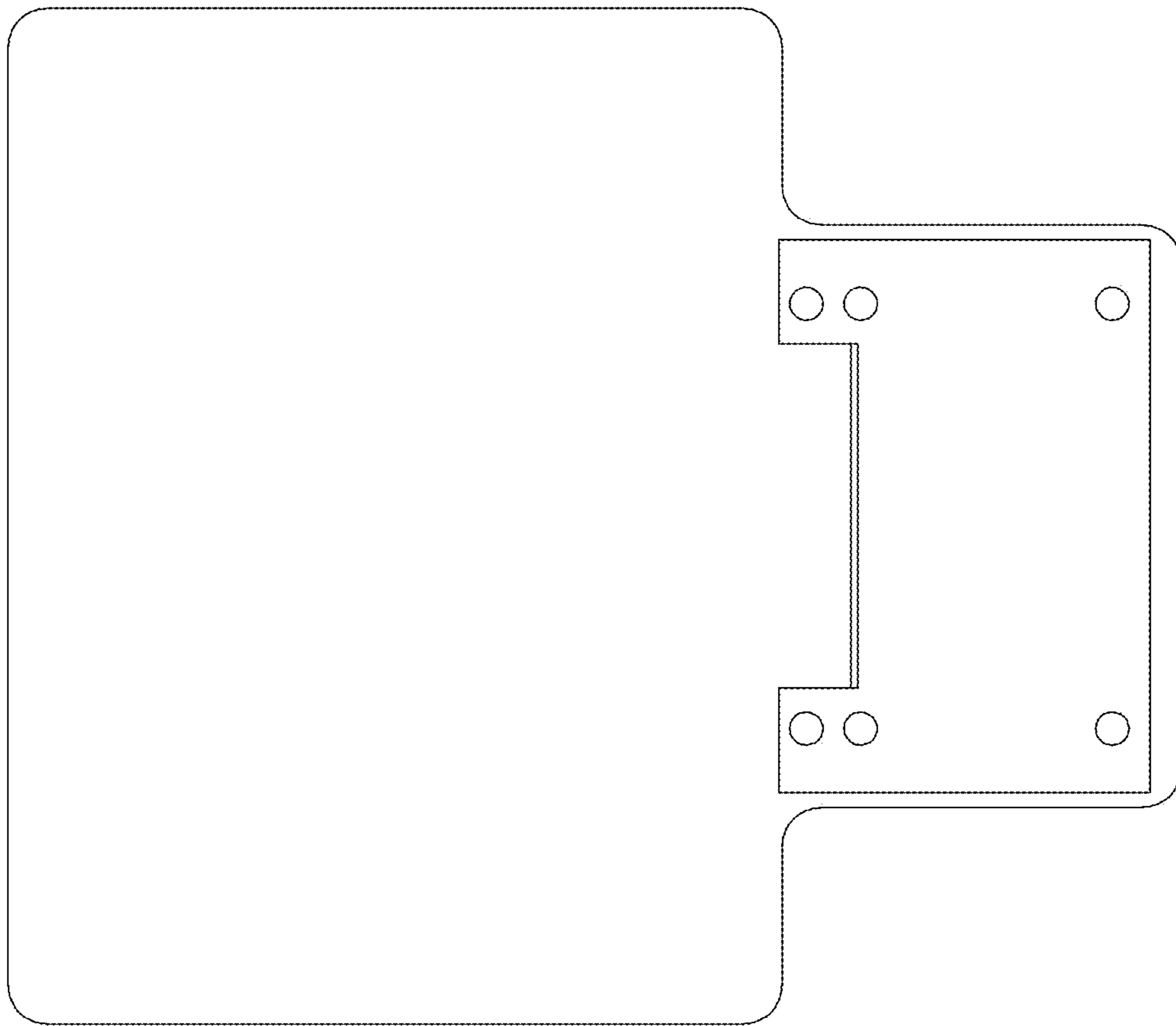

FIG. 4

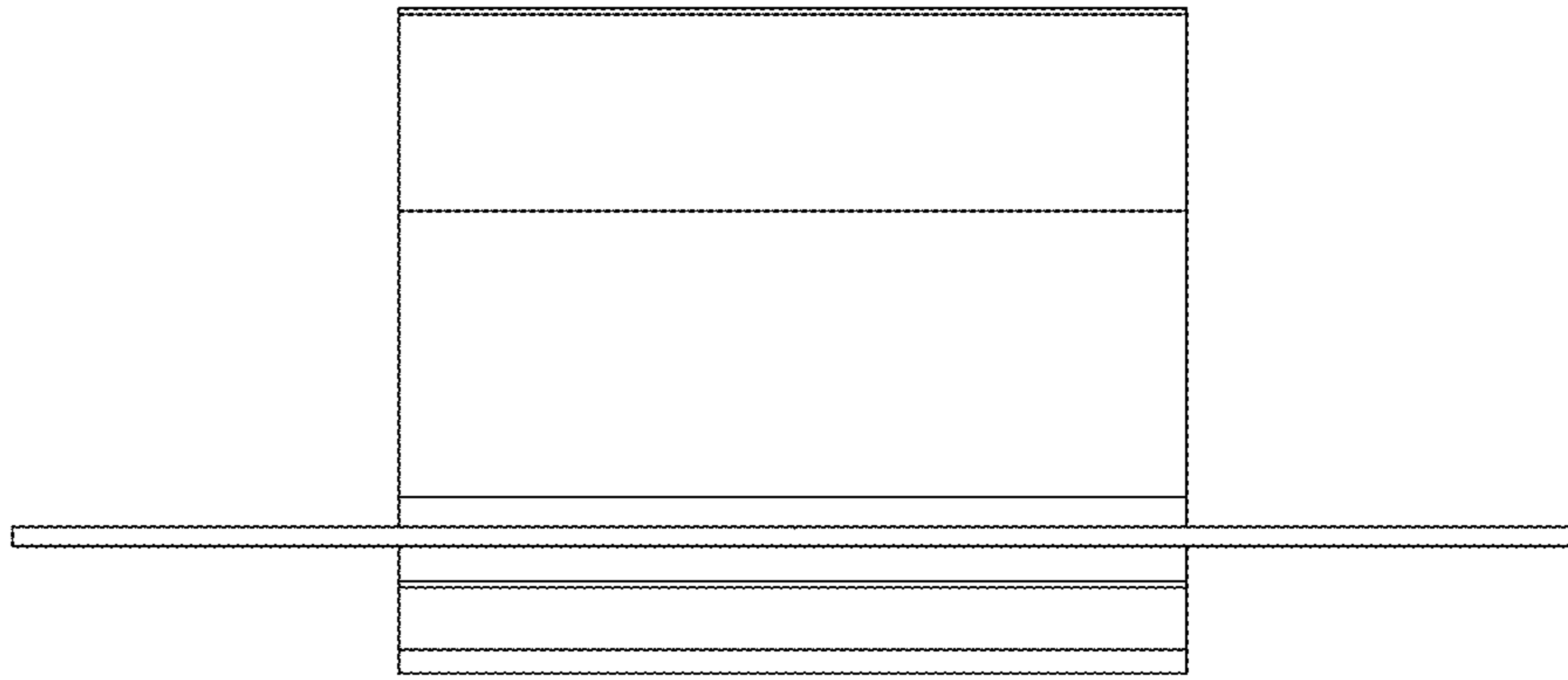

FIG. 5

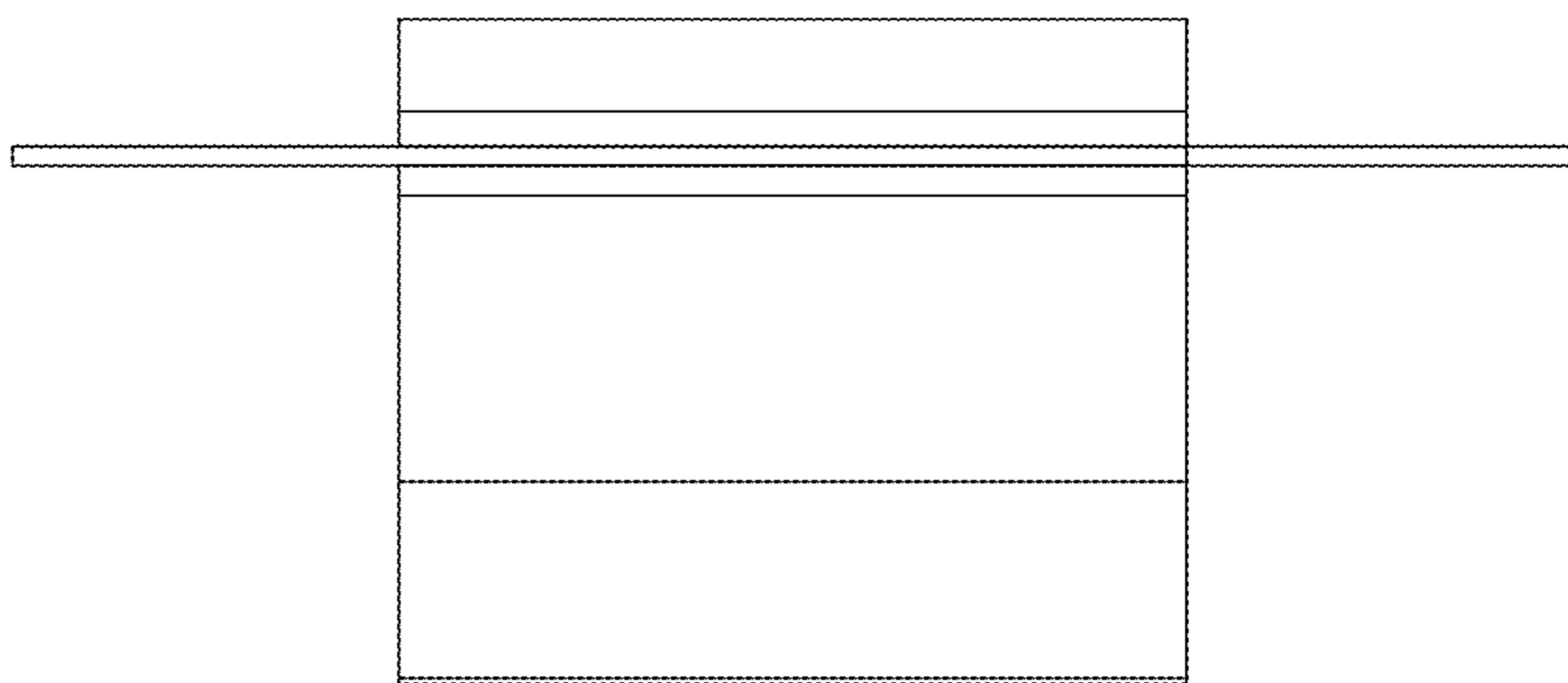

FIG. 6

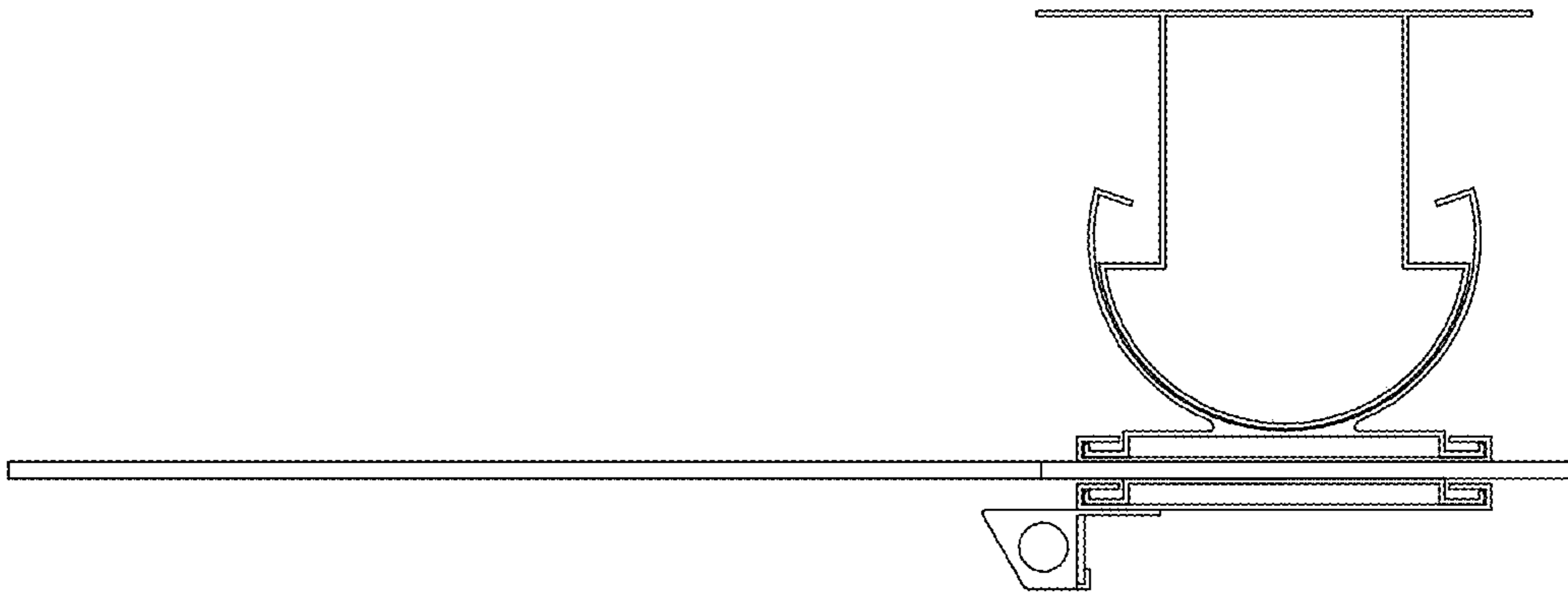

FIG. 7

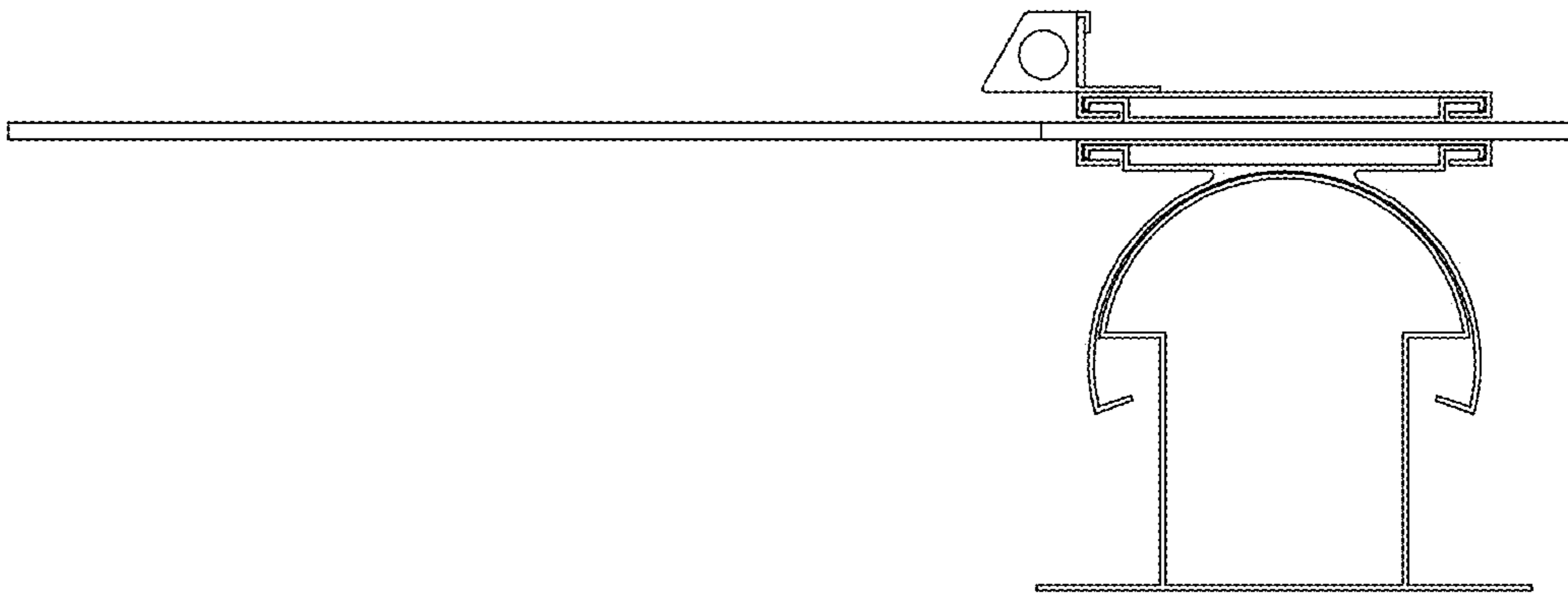

FIG. 8



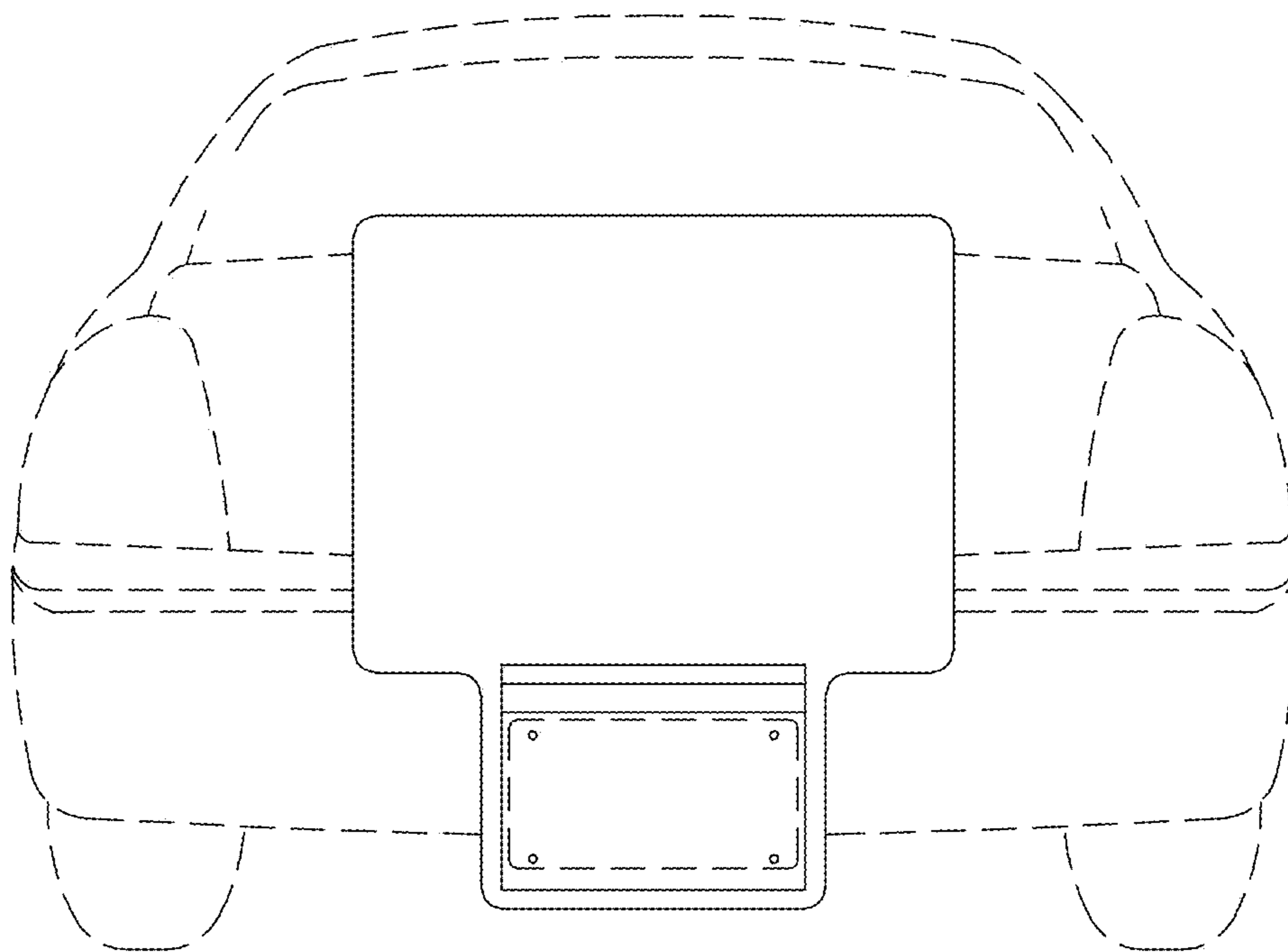

FIG. 9