



US00D879681S

(12) **United States Design Patent** (10) **Patent No.:** **US D879,681 S**
Melville-Brown (45) **Date of Patent:** **** Mar. 31, 2020**

(54) **FRONT BUMPER**

(71) Applicant: **HONDA MOTOR CO., LTD.**, Tokyo (JP)

(72) Inventor: **Guy Thomas Melville-Brown**, Manhattan Beach, CA (US)

(73) Assignee: **HONDA MOTOR CO., LTD.**, Tokyo (JP)

(**) Term: **15 Years**

(21) Appl. No.: **29/654,780**

(22) Filed: **Jun. 27, 2018**

(51) **LOC (12) Cl.** **12-16**

(52) **U.S. Cl.**
USPC **D12/169**

(58) **Field of Classification Search**
USPC D12/169, 86, 90–92; 293/102, 113, 115, 293/117, 120; 296/180.1, 180.2
CPC B60R 19/02; B60R 19/04; B62D 25/08
See application file for complete search history.

(56) **References Cited**

U.S. PATENT DOCUMENTS

D698,290 S *	1/2014	Mori	D12/169
D703,592 S *	4/2014	Kwon	D12/169
D713,304 S *	9/2014	Tsuchida	D12/169
D714,196 S *	9/2014	Mays	D12/169
D715,708 S *	10/2014	Mays	D12/169
D718,678 S *	12/2014	Ishizuka	D12/169
D729,138 S	5/2015	Davidson et al.		
D735,097 S *	7/2015	Nissl	D12/169
D737,741 S *	9/2015	Goepfel	D12/169
D738,800 S *	9/2015	Mueller-Stolz	D12/169
D740,728 S *	10/2015	Gunnarson	D12/169
D752,484 S	3/2016	Davidson et al.		
D759,540 S	6/2016	Davidson et al.		
D760,628 S	7/2016	Davidson et al.		
D761,457 S	7/2016	Davidson et al.		

(Continued)

OTHER PUBLICATIONS

“2018 Honda Pilot—The Modern Midsize Family Suv,” Honda Motor. Co., <https://automobiles.honda.com/pilot>, accessed Jun. 18, 2018.

Primary Examiner — Melody N Brown

(74) *Attorney, Agent, or Firm* — Arent Fox LLP

(57) **CLAIM**

The ornamental design for a front bumper, as shown and described.

DESCRIPTION

FIG. 1 is a right, front perspective view of a front bumper showing my new design;
FIG. 2 is a left, rear perspective view thereof;
FIG. 3 is a left, front perspective view thereof;
FIG. 4 is a right, rear perspective view thereof;
FIG. 5 is a front elevational view thereof;
FIG. 6 is a rear elevational view thereof;
FIG. 7 is a left side elevational view thereof;
FIG. 8 is a right side elevational view thereof;
FIG. 9 is a top plan view thereof;
FIG. 10 is a bottom plan view thereof;
FIG. 11 is a right, front perspective view of a front bumper showing a second embodiment of my new design;
FIG. 12 is a left, rear perspective view of FIG. 11;
FIG. 13 is a left, front perspective view of FIG. 11;
FIG. 14 is a right, rear perspective view of FIG. 11;
FIG. 15 is a front elevational view of FIG. 11;
FIG. 16 is a rear elevational view of FIG. 11;
FIG. 17 is a left side elevational view of FIG. 11;
FIG. 18 is a right side elevational view of FIG. 11;
FIG. 19 is a top plan view of FIG. 11; and,
FIG. 20 is a bottom plan view of FIG. 11.

The broken lines shown in the figures are included for the purpose of illustrating portions of the front bumper and form no part of the claimed design.

1 Claim, 20 Drawing Sheets

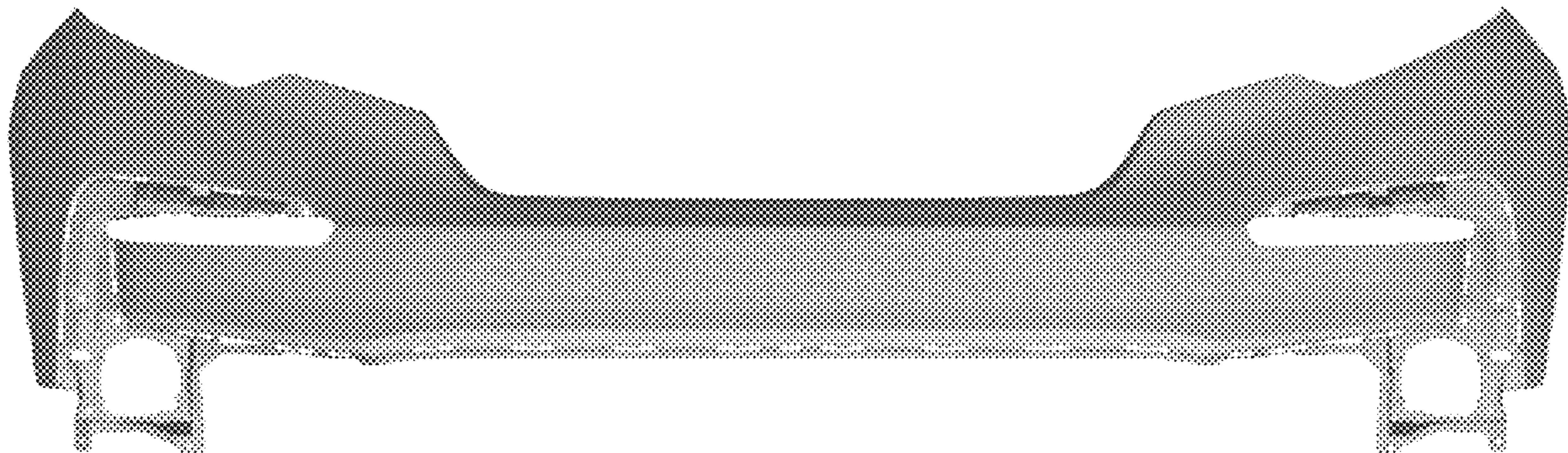

(56)

References Cited

U.S. PATENT DOCUMENTS

D764,083 S	8/2016	Davidson et al.	
D765,567 S *	9/2016	De Bono	D12/169
D767,467 S	9/2016	Davidson et al.	
D772,117 S	11/2016	Davidson et al.	
D774,427 S	12/2016	Davidson et al.	
D774,428 S	12/2016	Davidson et al.	
D801,885 S *	11/2017	Melikian	D12/169
D841,537 S *	2/2019	Morikawa	D12/169
D856,224 S *	8/2019	Nissl	D12/169

* cited by examiner

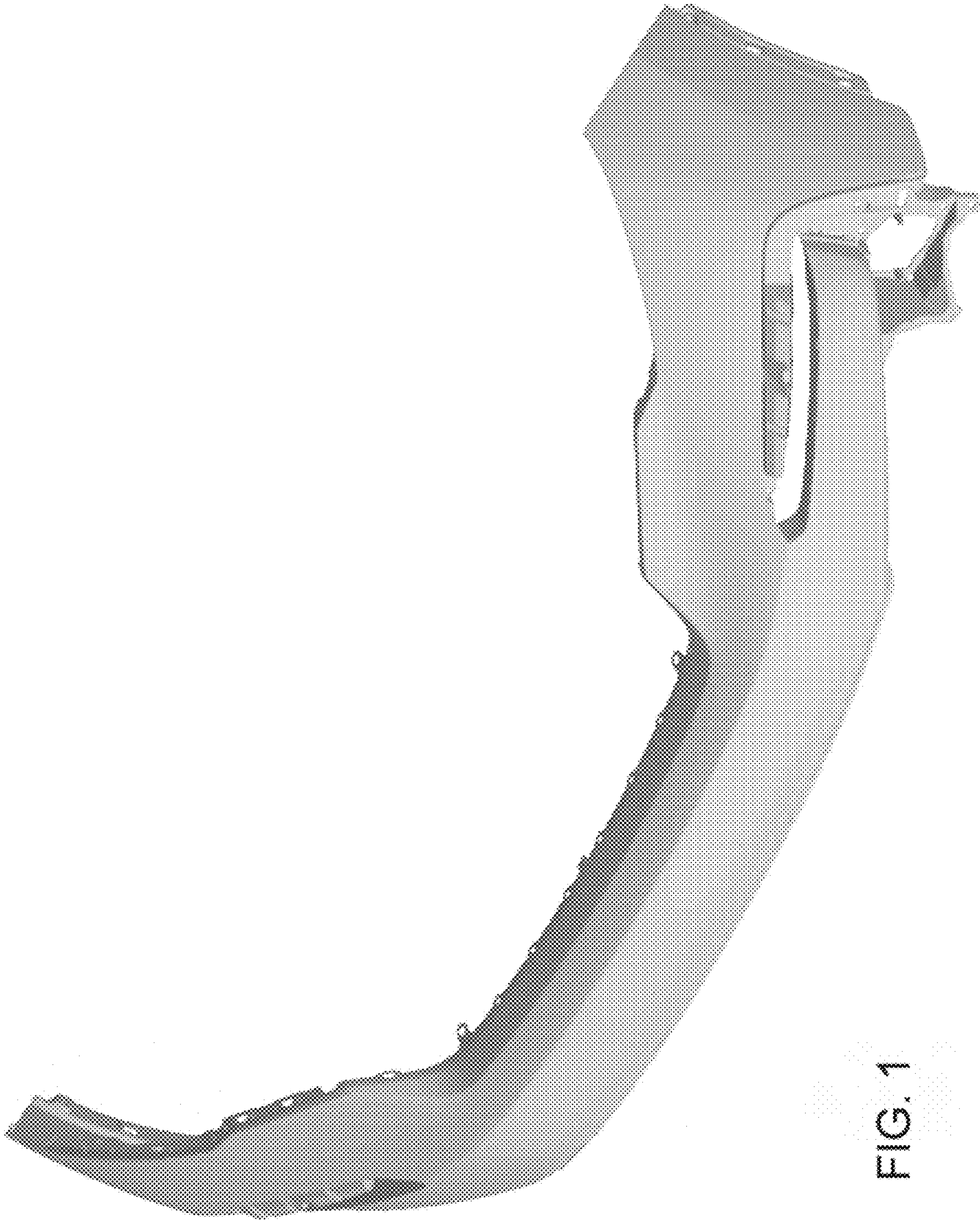

FIG. 1

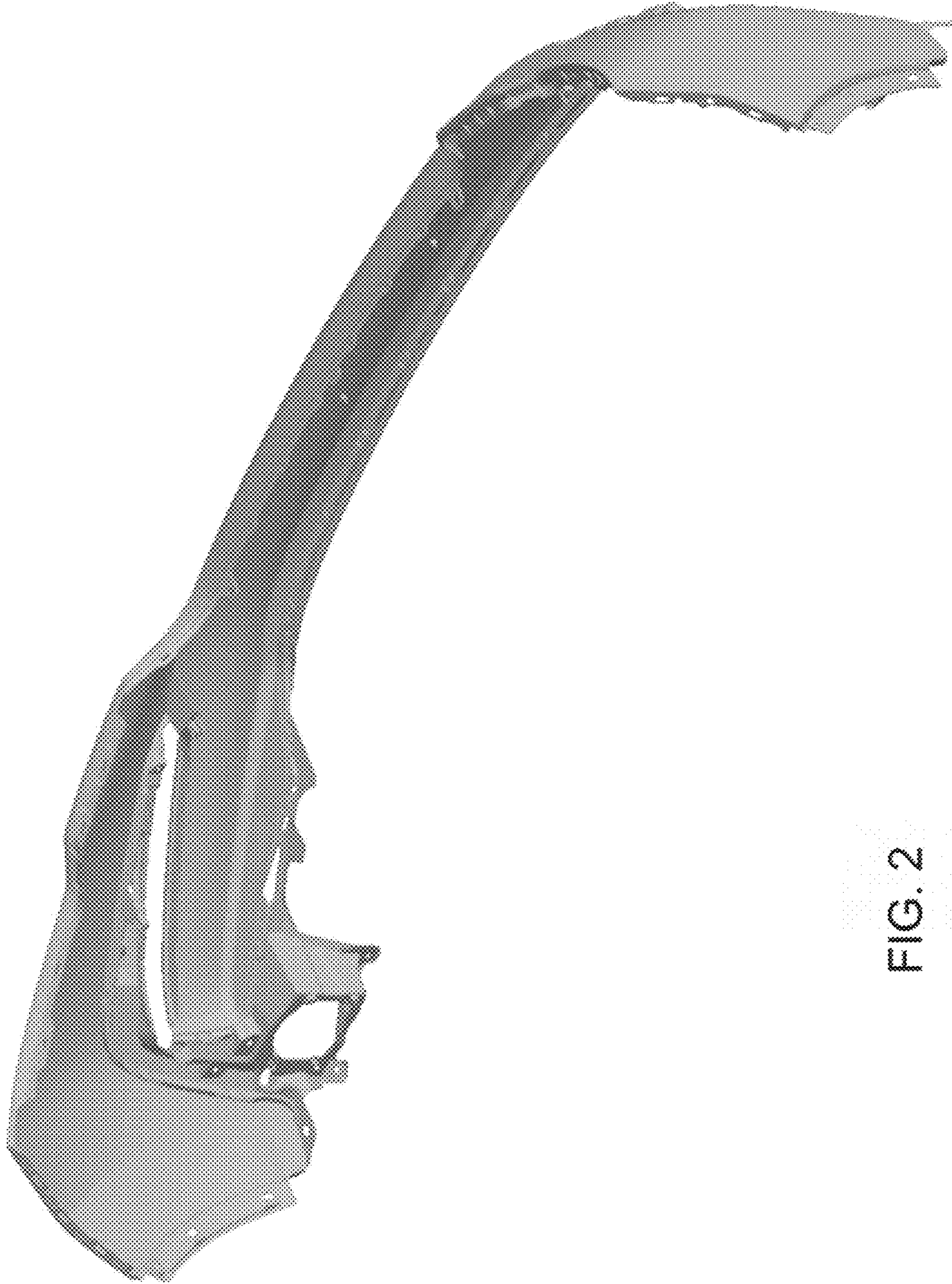

FIG. 2

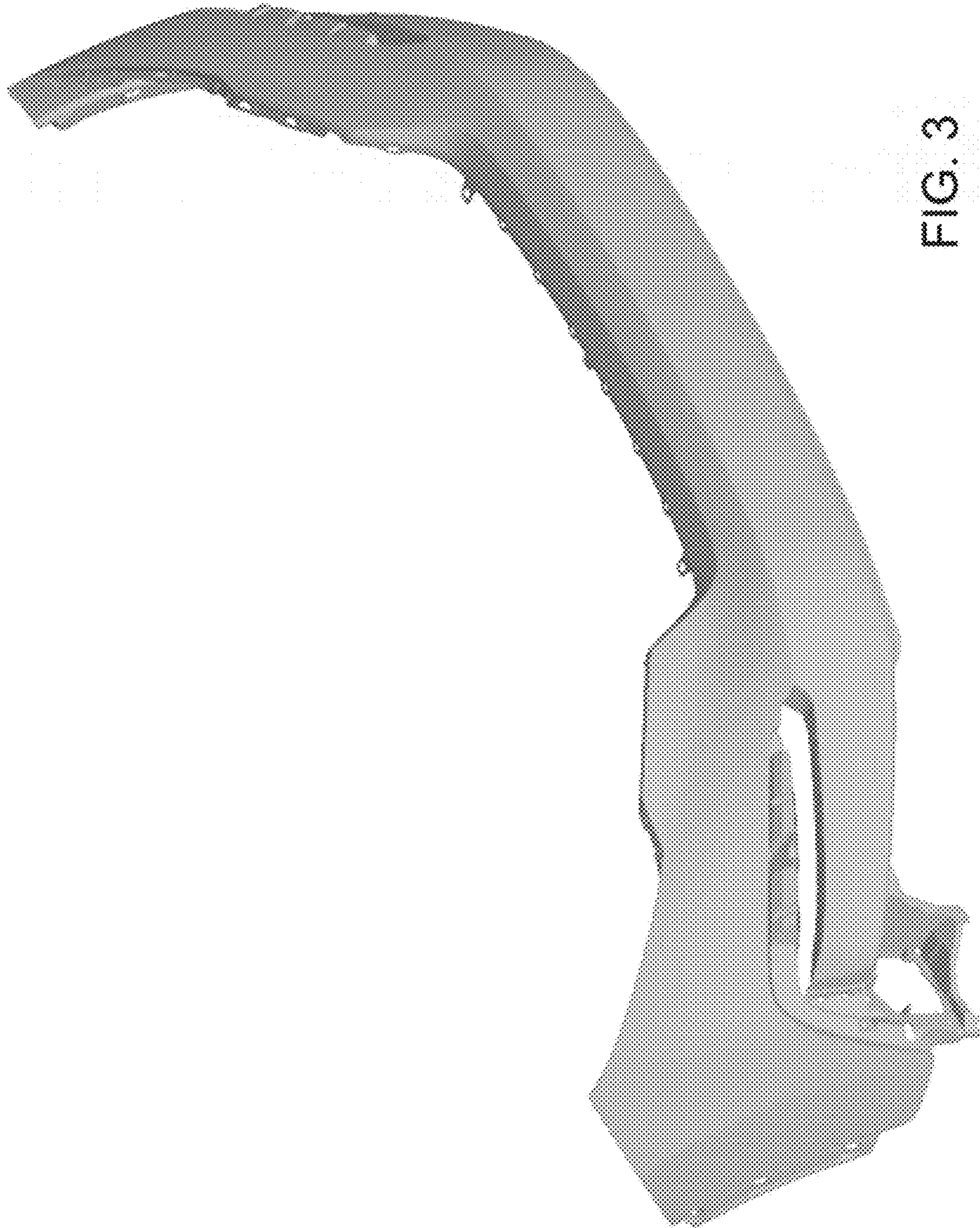

FIG. 3

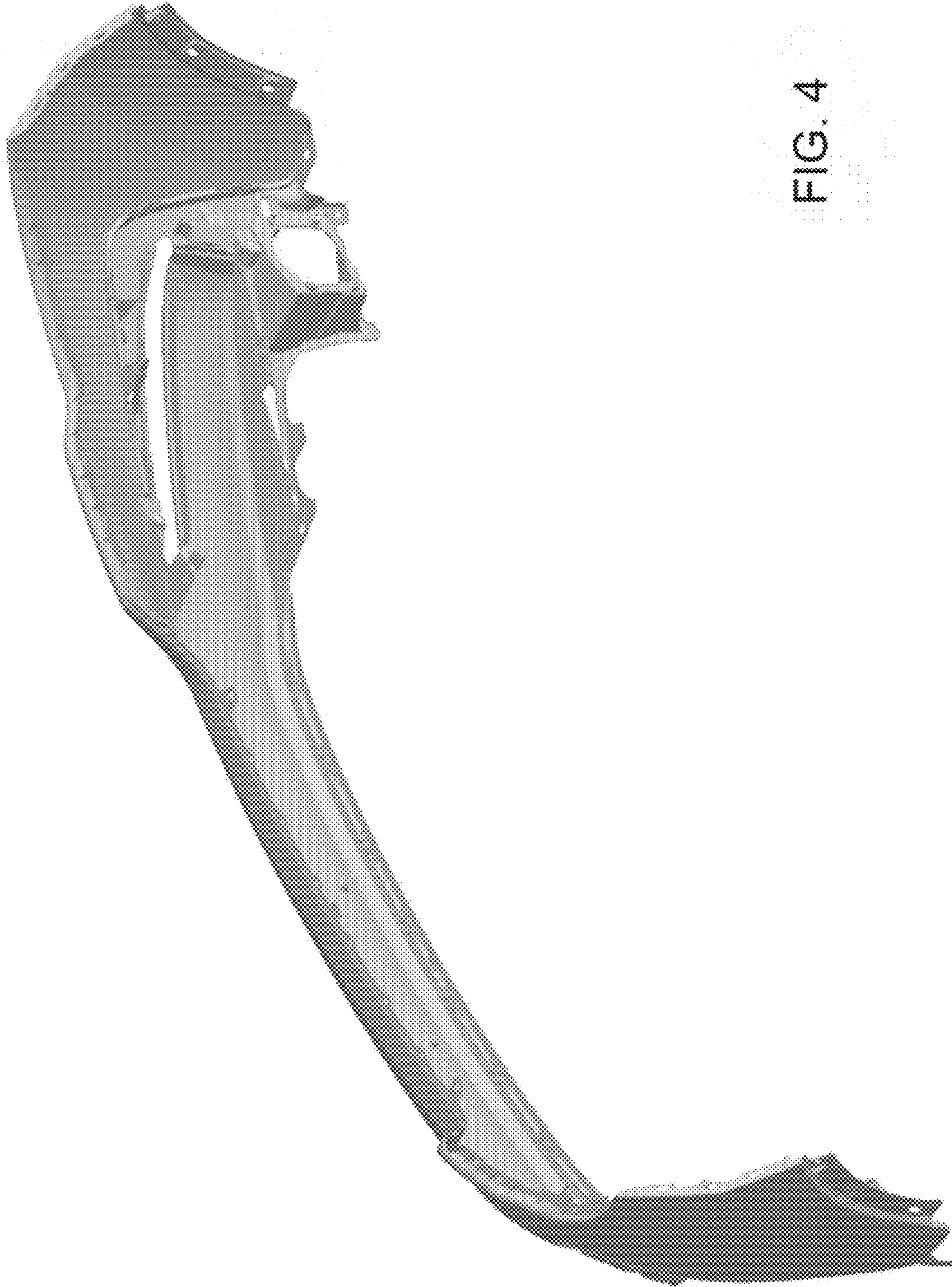

FIG. 4

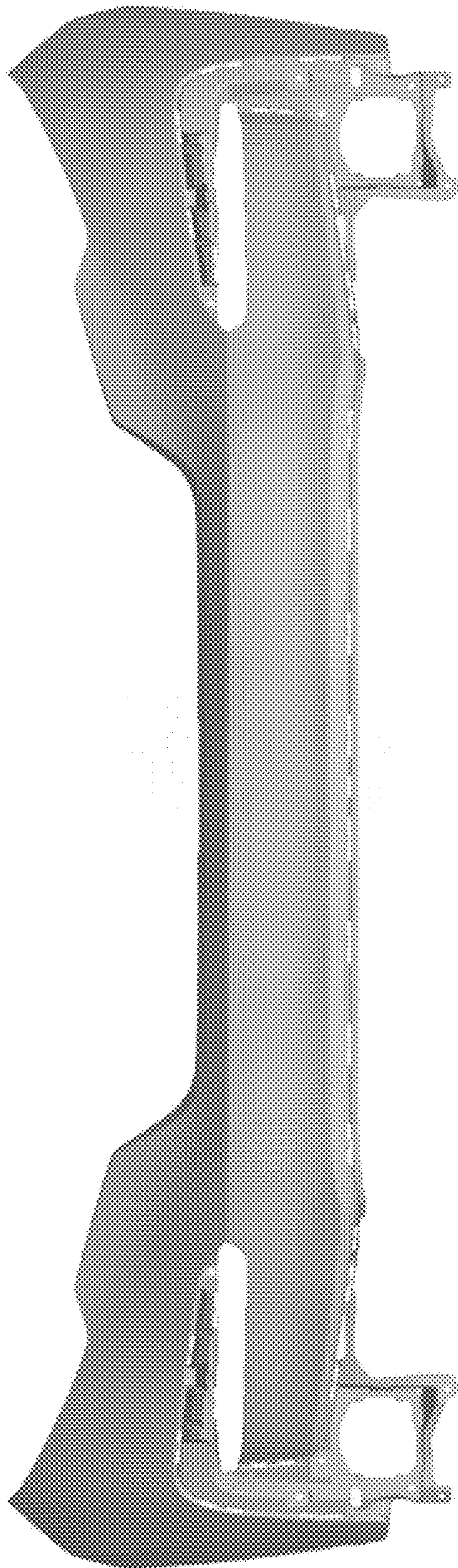

FIG. 5

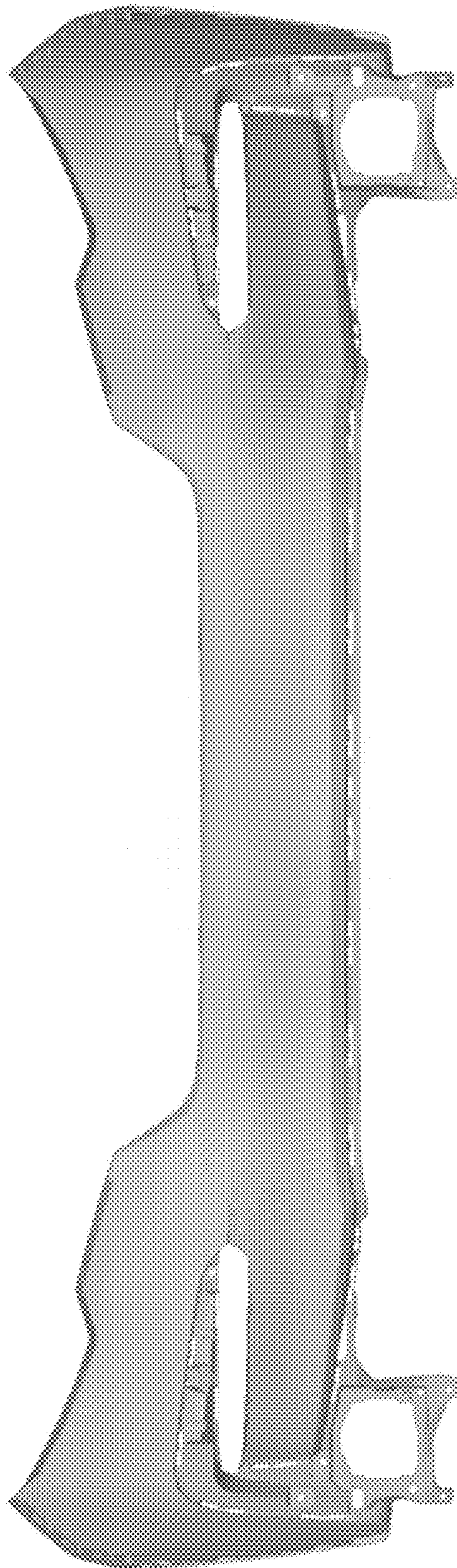

FIG. 6

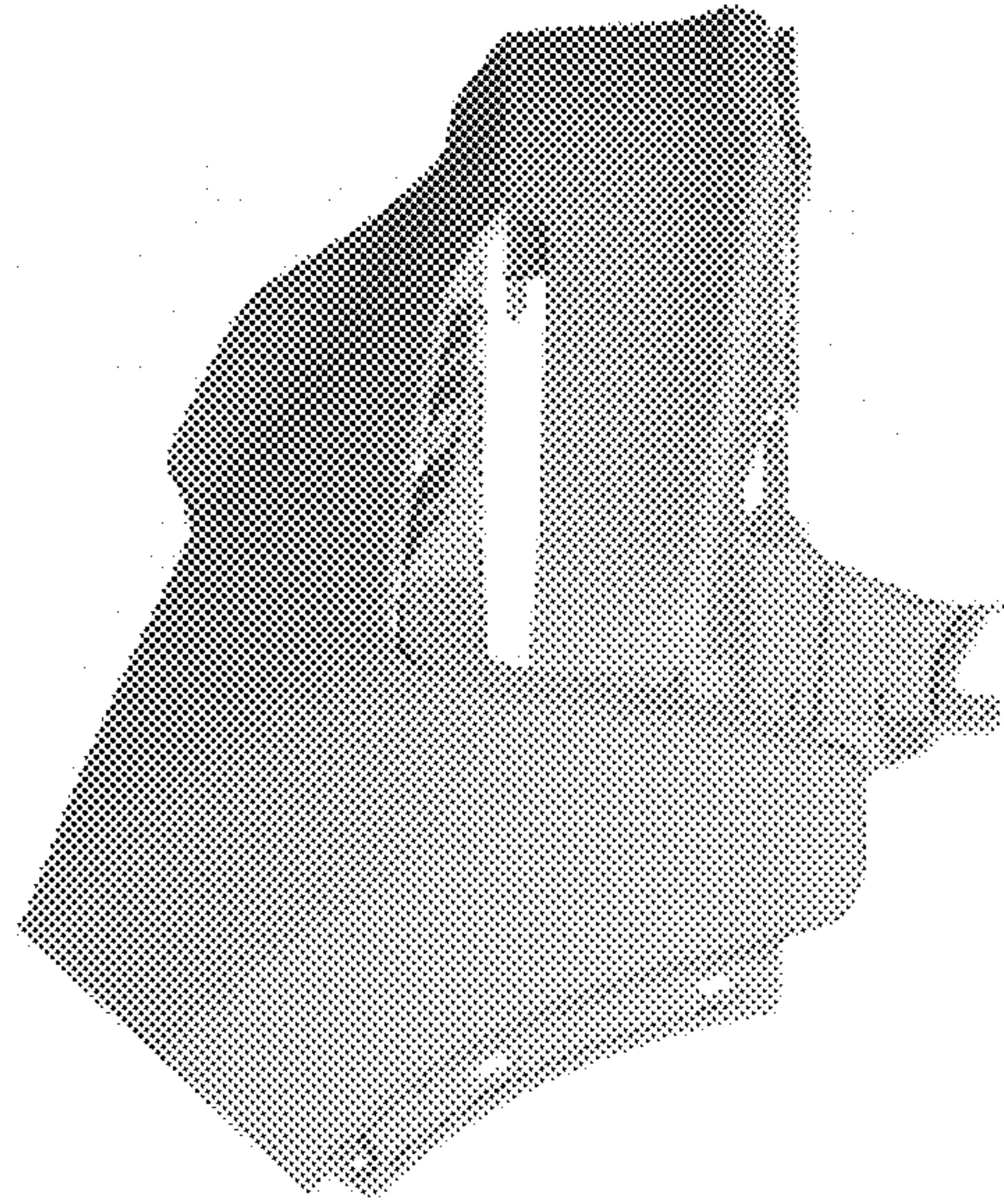

FIG. 7

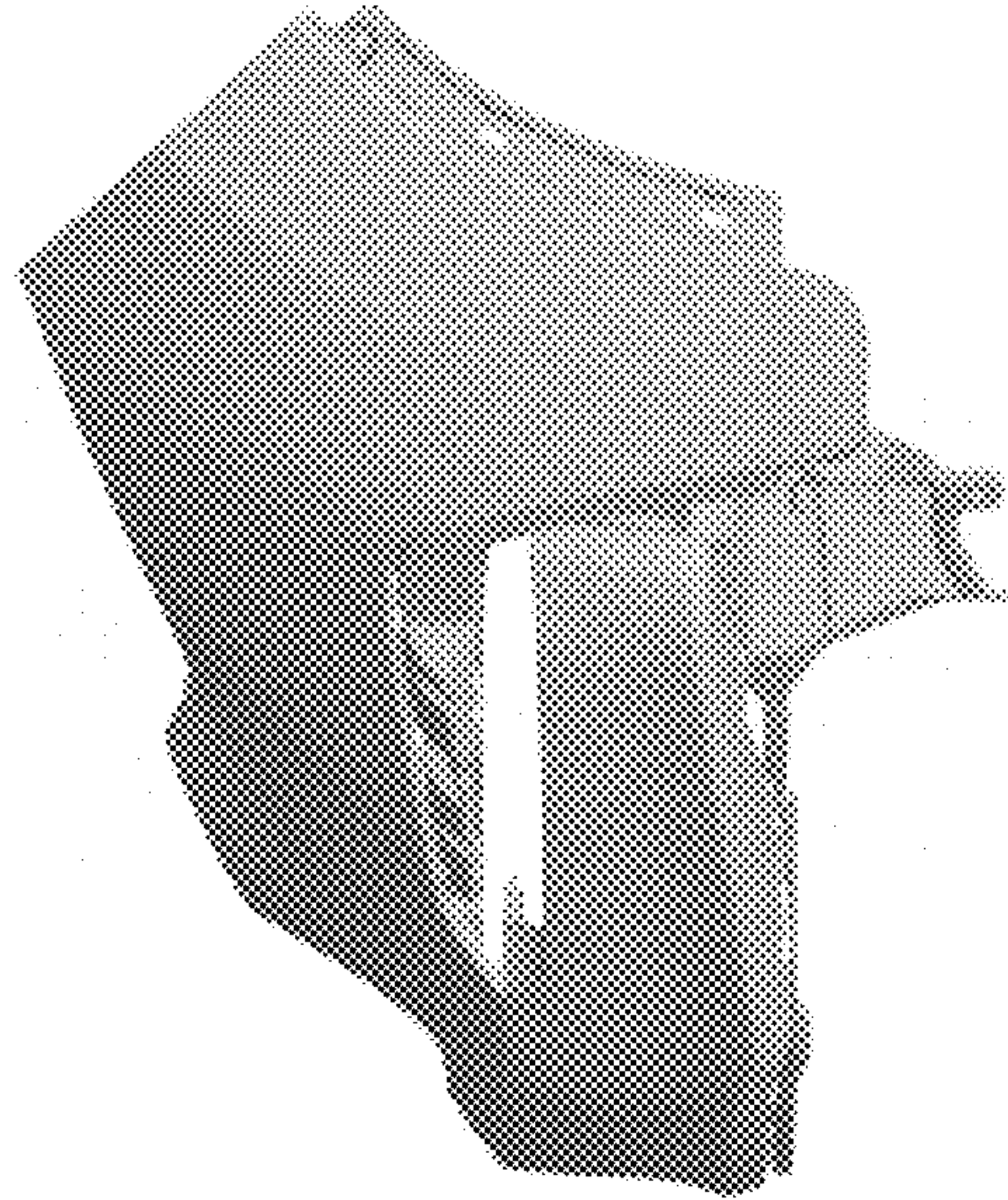

FIG. 8

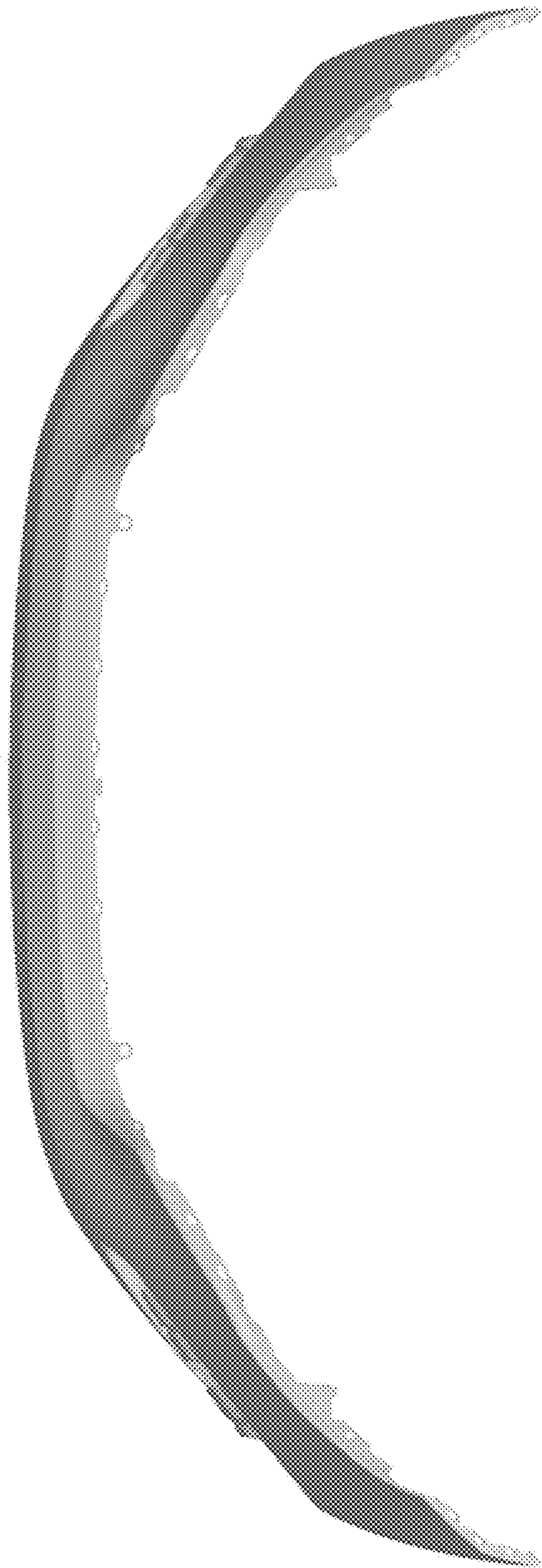

FIG. 9

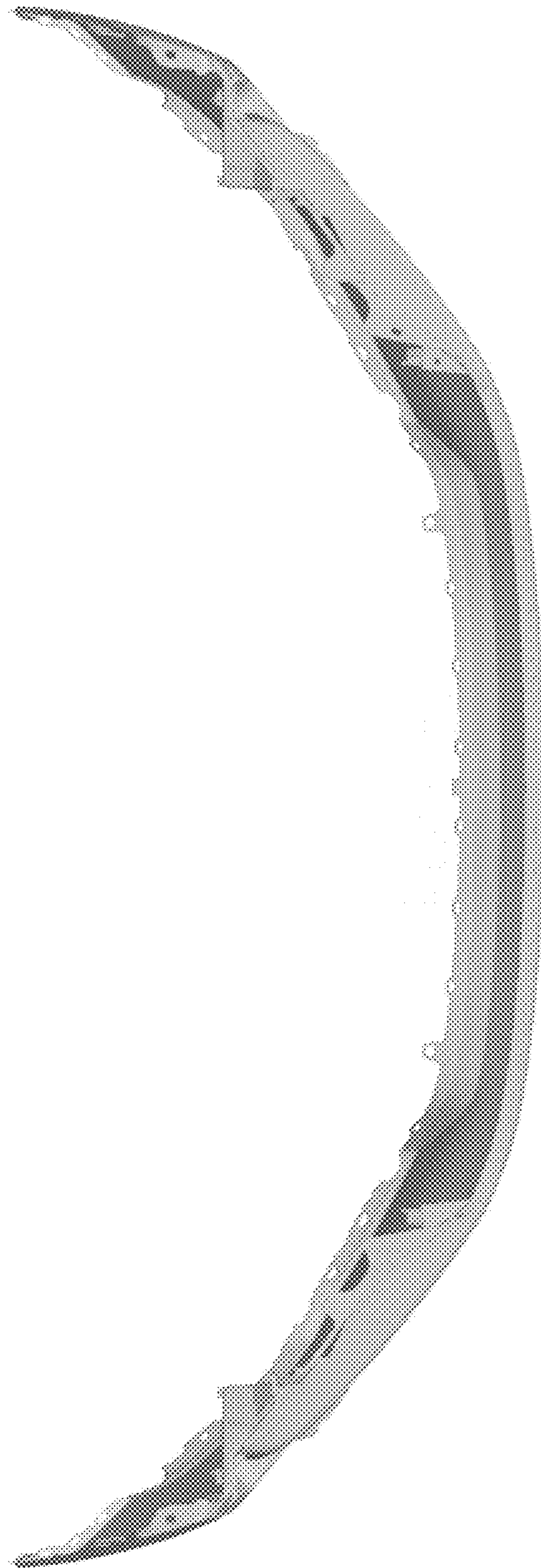

FIG. 10

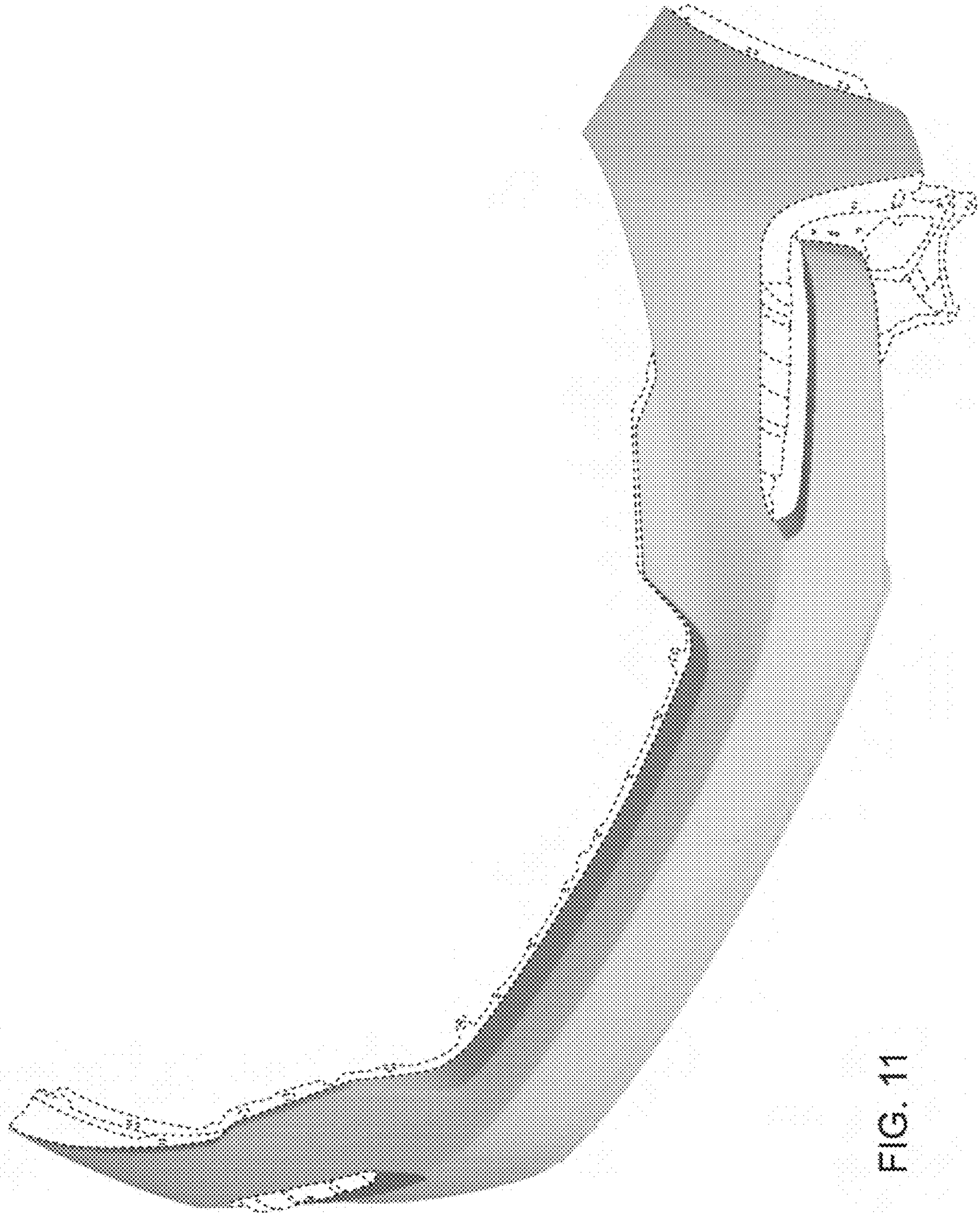

FIG. 11

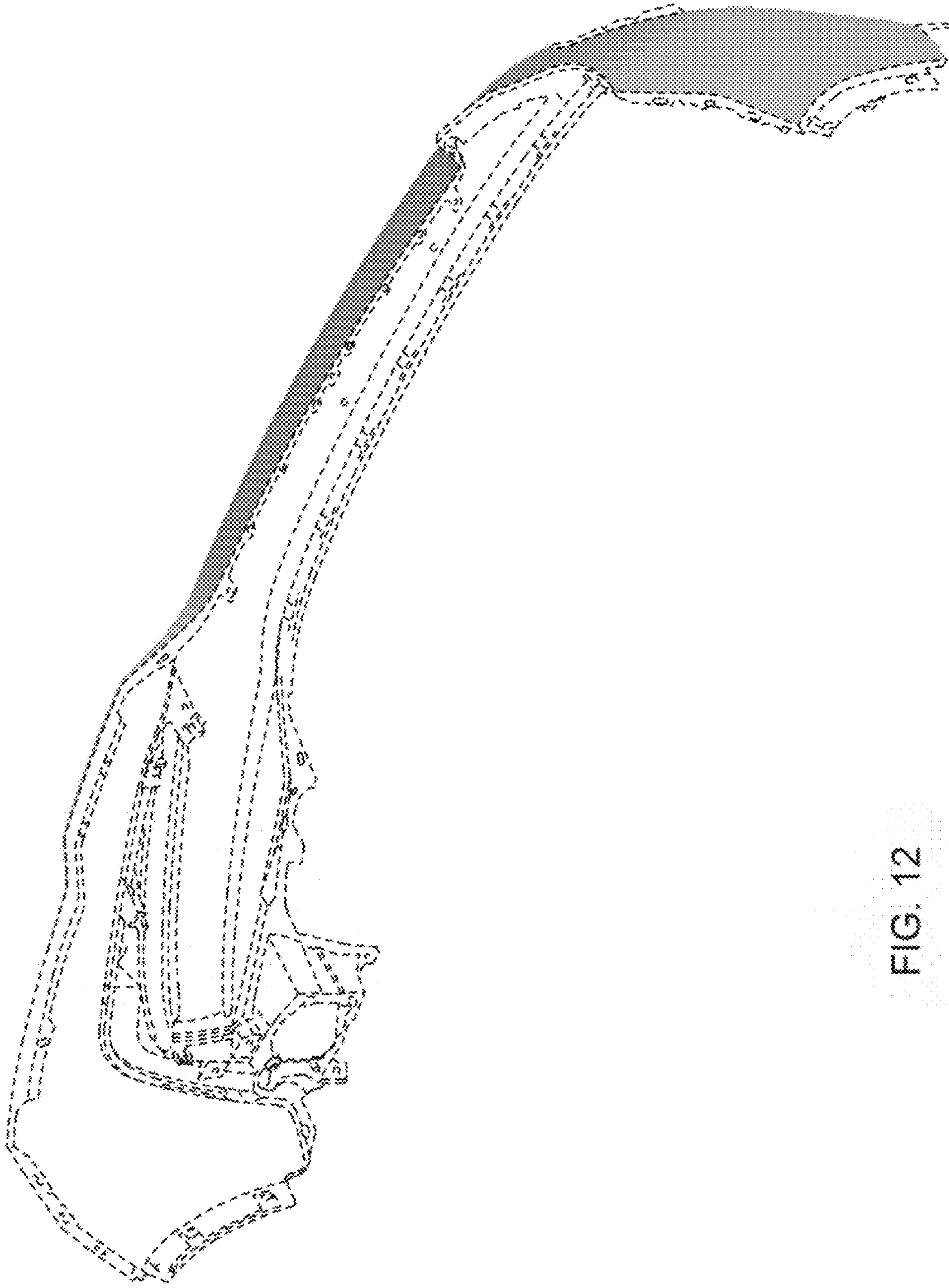

FIG. 12

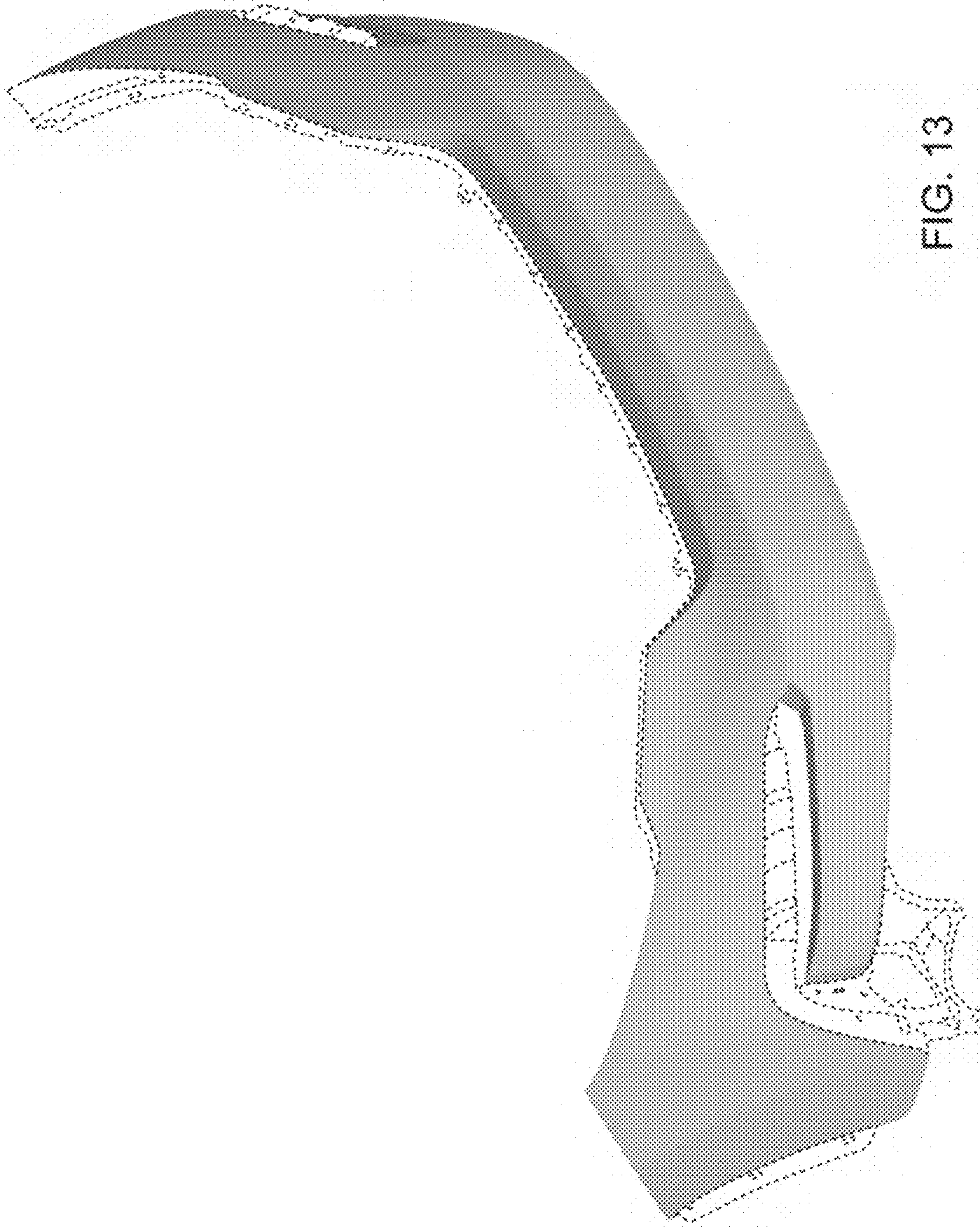

FIG. 13

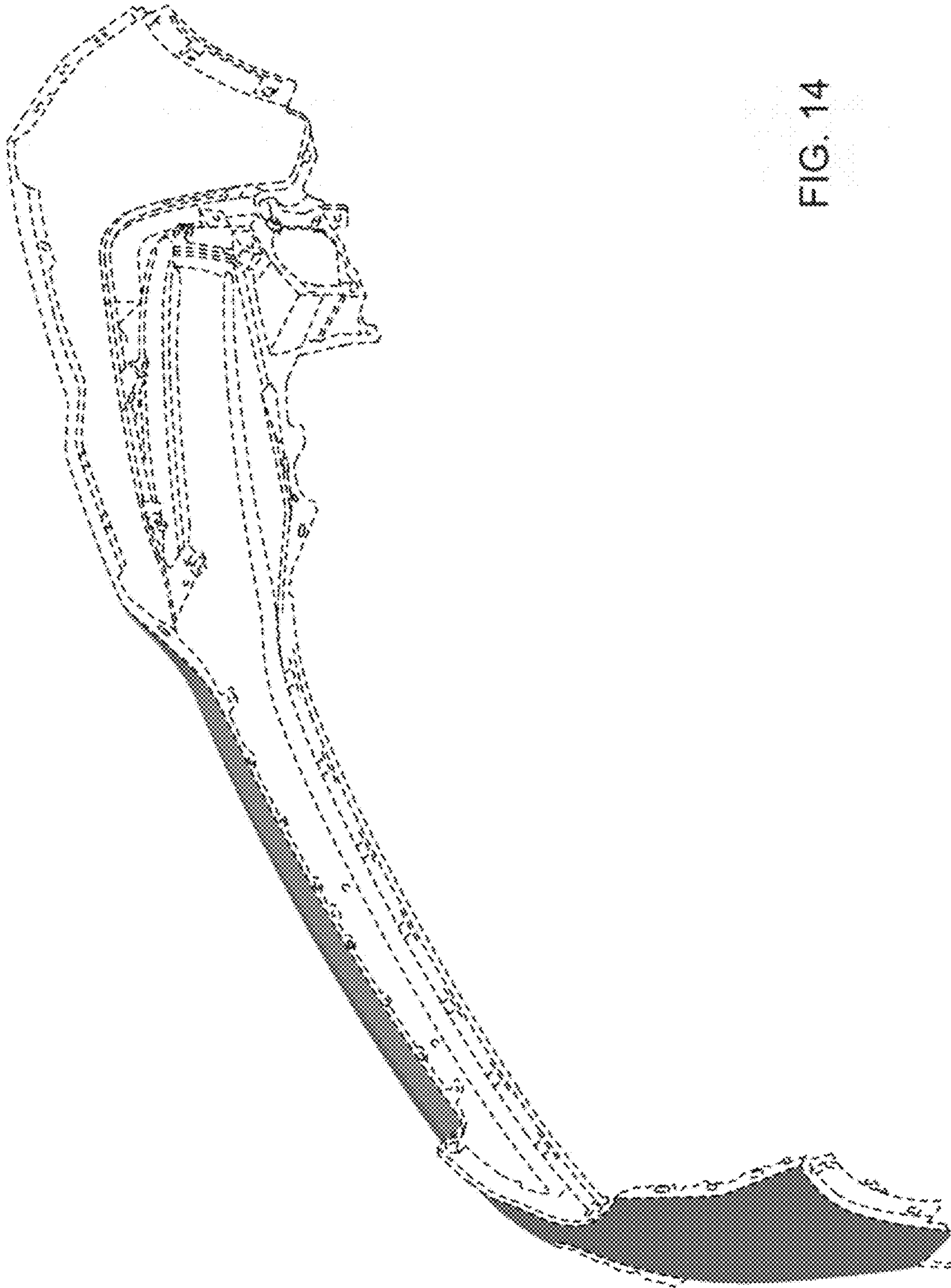

FIG. 14

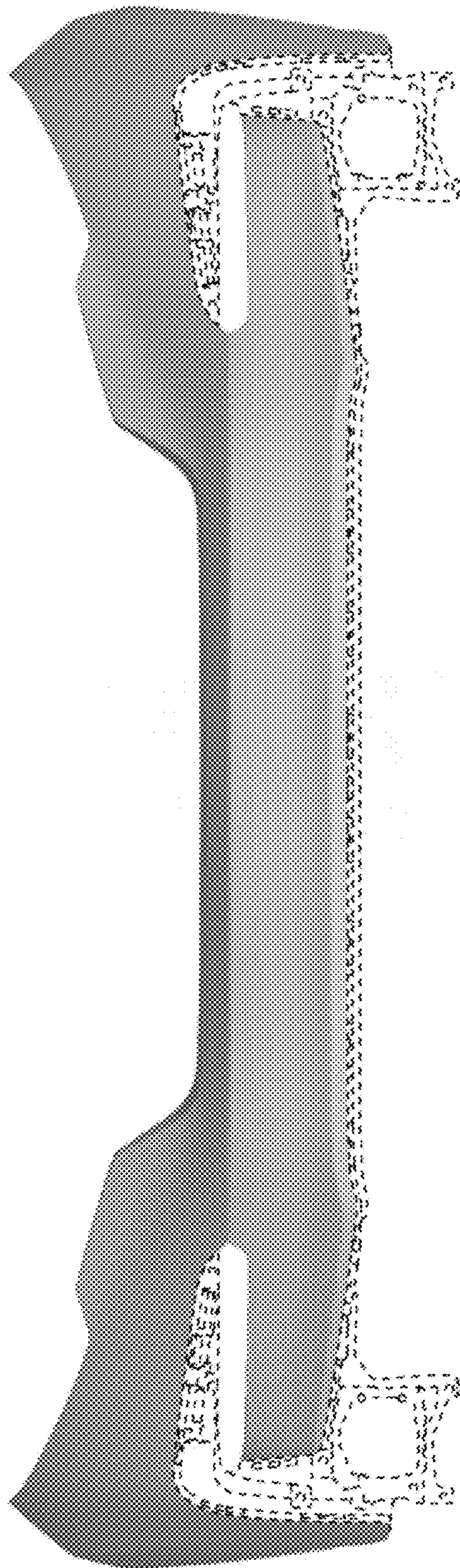

FIG. 15

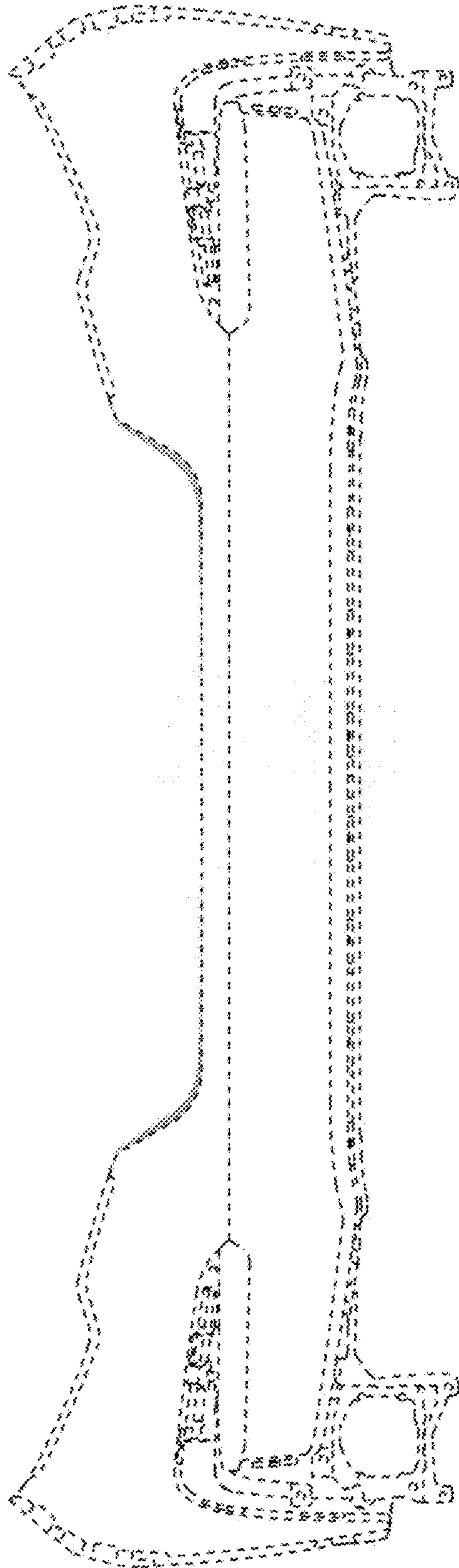

FIG. 16

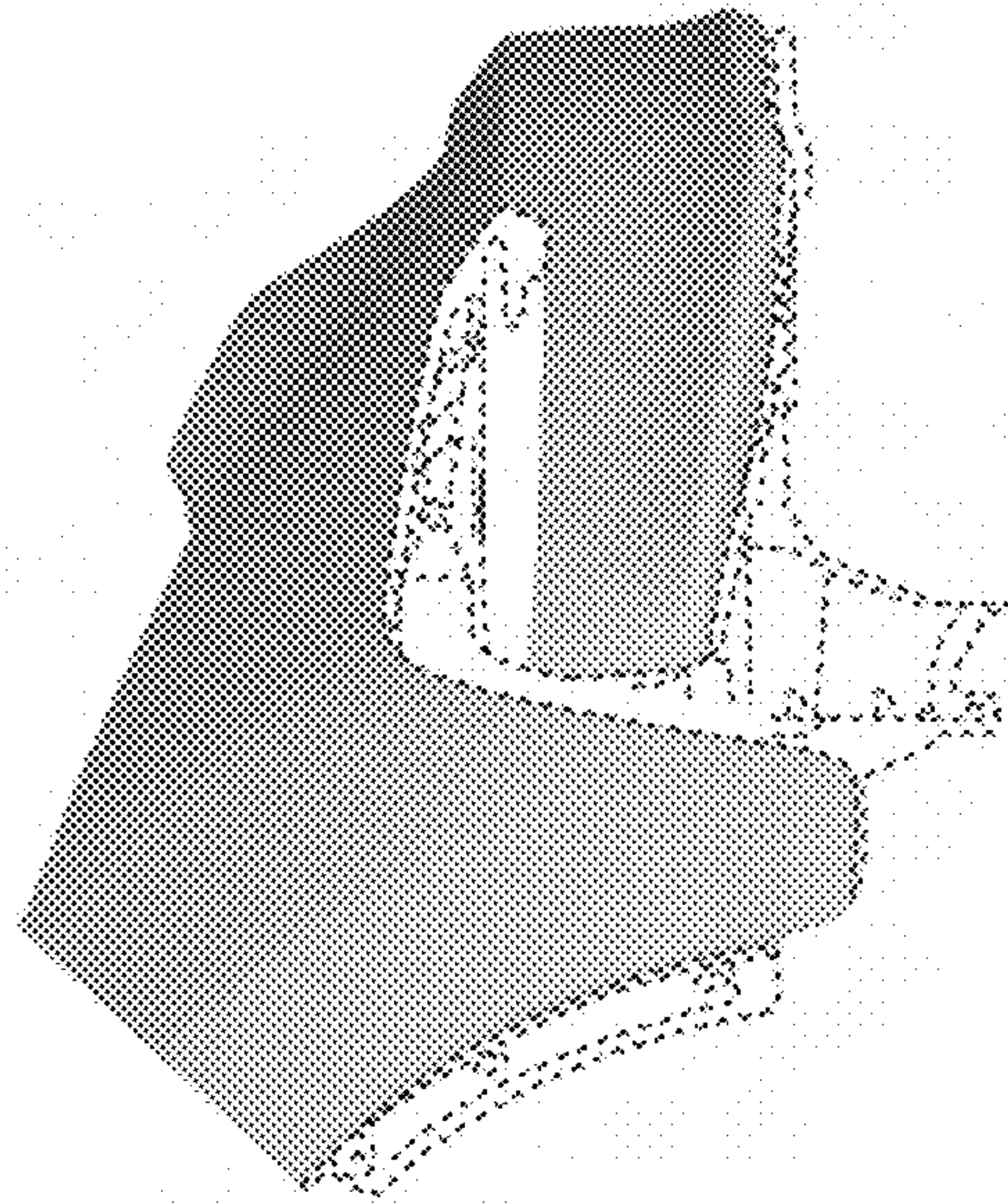

FIG. 17

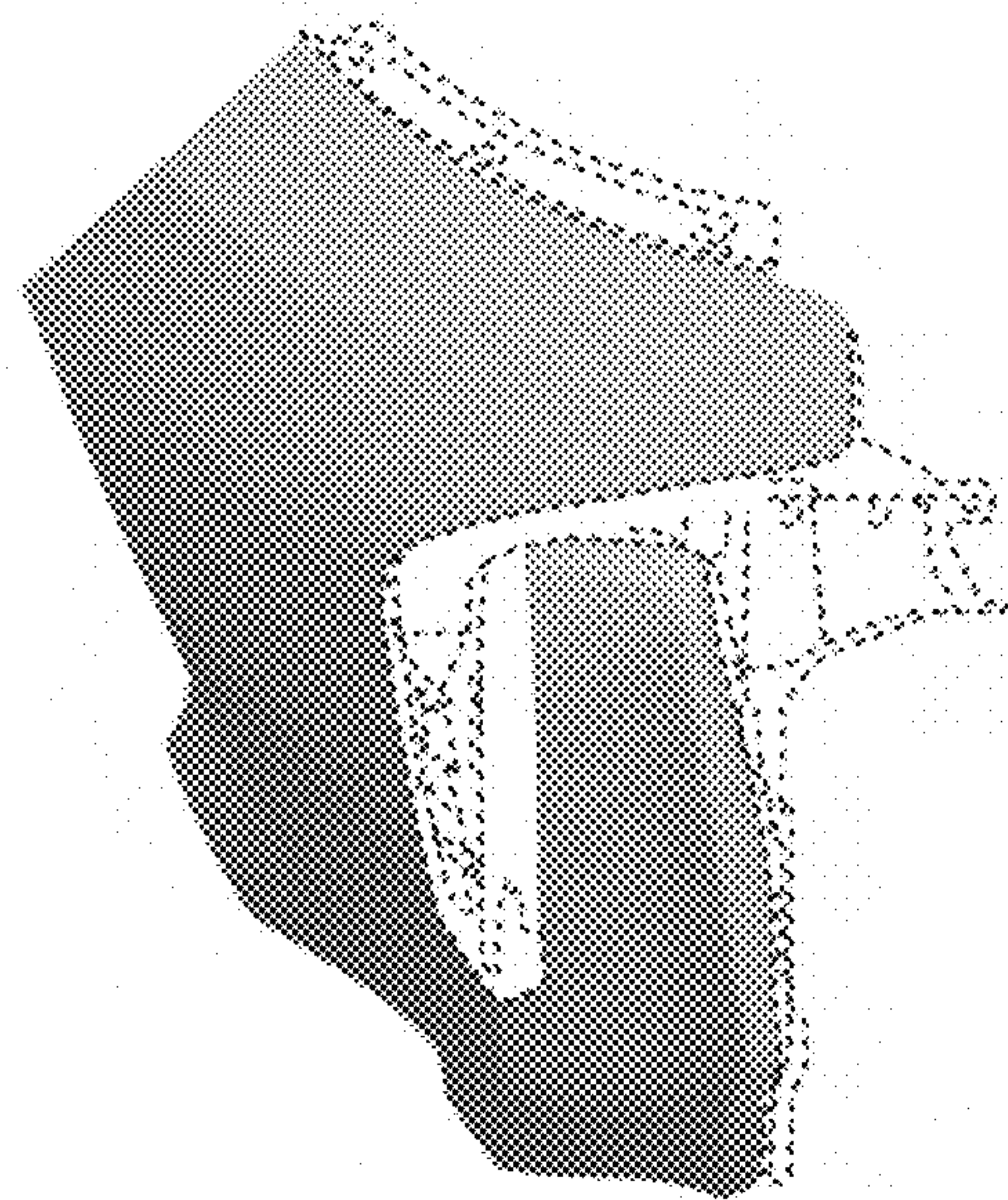

FIG. 18

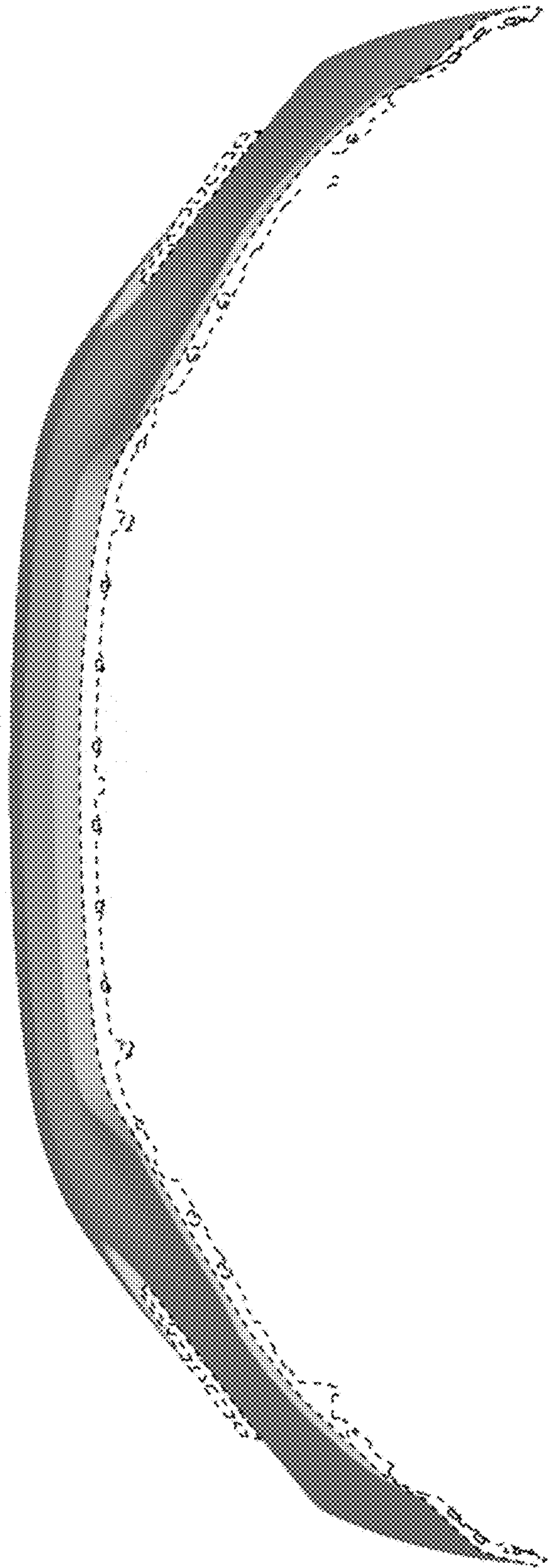

FIG. 19

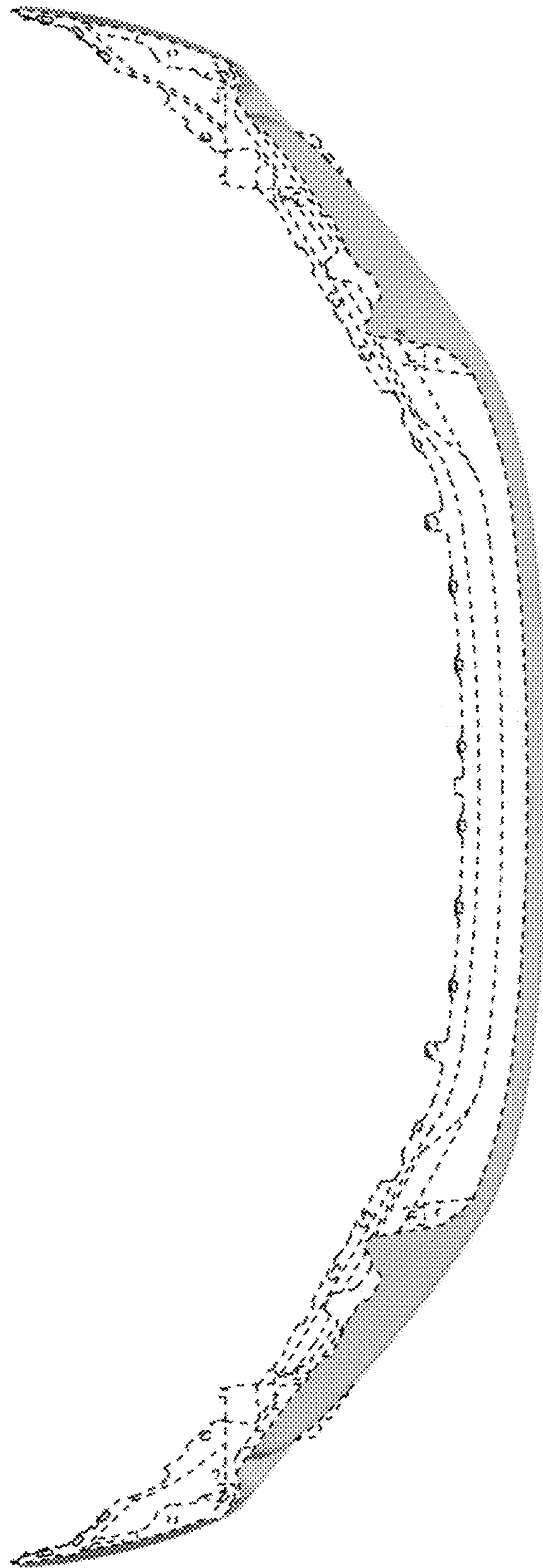

FIG. 20