



US00D879667S

(12) **United States Design Patent**
Galluzzi

(10) **Patent No.:** **US D879,667 S**
(45) **Date of Patent:** **** Mar. 31, 2020**

(54) **MOTORCYCLE**

(71) Applicant: **PIAGGIO & C. S.p.A.**, Pontedera
(Pisa) (IT)

(72) Inventor: **Miguel Galluzzi**, Pontedera (IT)

(73) Assignee: **PIAGGIO & C. S.P.A.**, Pontedera
(Pisa) (IT)

(**) Term: **14 Years**

(21) Appl. No.: **29/524,902**

(22) Filed: **Apr. 24, 2015**

(30) **Foreign Application Priority Data**

Oct. 31, 2014 (EM) 002569285

(51) **LOC (12) Cl.** **12-11**

(52) **U.S. Cl.**
USPC **D12/110**

(58) **Field of Classification Search**
USPC D12/109, 110, 111, 114, 117, 126, 184,
D12/186; D21/432, 458, 538;
180/210-217, 219, 220, 225, 229, 908;
280/103, 124, 152.1-152.3, 288.2, 288.4,
280/304.3, 770, 827, 828, 847, 848;
296/77.1, 78.1, 181.1, 187.01, 187.12,
296/192, 193.01, 193.04, 193.05, 193.09;
446/440

CPC B62D 37/00; B62D 57/00; B62K 9/00;
B62K 11/04; B62K 17/00; B62K 19/48;
B62M 7/12; F02B 61/02; A63H 17/21;
B62J 17/00; B62J 17/04; B62J 29/00

See application file for complete search history.

(56) **References Cited**

U.S. PATENT DOCUMENTS

4,809,800	A *	3/1989	Suzuki	B62K 11/00 180/219
D384,916	S *	10/1997	Rodriguez Ferre	D12/110
D426,174	S *	6/2000	Sofue	D12/110
D444,419	S *	7/2001	Kamata	D12/110
D476,271	S *	6/2003	Abe	D12/110
D529,415	S	10/2006	Shimada et al.	
D538,201	S	3/2007	Kume et al.	
D588,502	S	3/2009	Kume et al.	
D605,982	S *	12/2009	Tanaka	D12/110
D624,853	S *	10/2010	Song	D12/110
D656,867	S *	4/2012	Uemoto	D12/110
D666,531	S *	9/2012	Dunshee	D12/110
D691,069	S *	10/2013	Tsukui	D12/110
D692,355	S *	10/2013	Tsuji	D12/110
D722,538	S *	2/2015	Song	D12/110
D735,616	S *	8/2015	Tako	D12/110

* cited by examiner

Primary Examiner — Darlington Ly

(74) *Attorney, Agent, or Firm* — Cantor Colburn LLP

(57) **CLAIM**

The ornamental design for a motorcycle, as shown and described.

DESCRIPTION

FIG. 1 is a front and left side perspective view of the motorcycle showing my new design;
FIG. 2 is a rear and left side perspective thereof;
FIG. 3 is a front view thereof;
FIG. 4 is a rear view thereof;
FIG. 5 is a left side view thereof;
FIG. 6 is a right side view thereof; and,
FIG. 7 is a top view thereof.
Where portions shown in broken lines form no part of the claimed design.

1 Claim, 7 Drawing Sheets

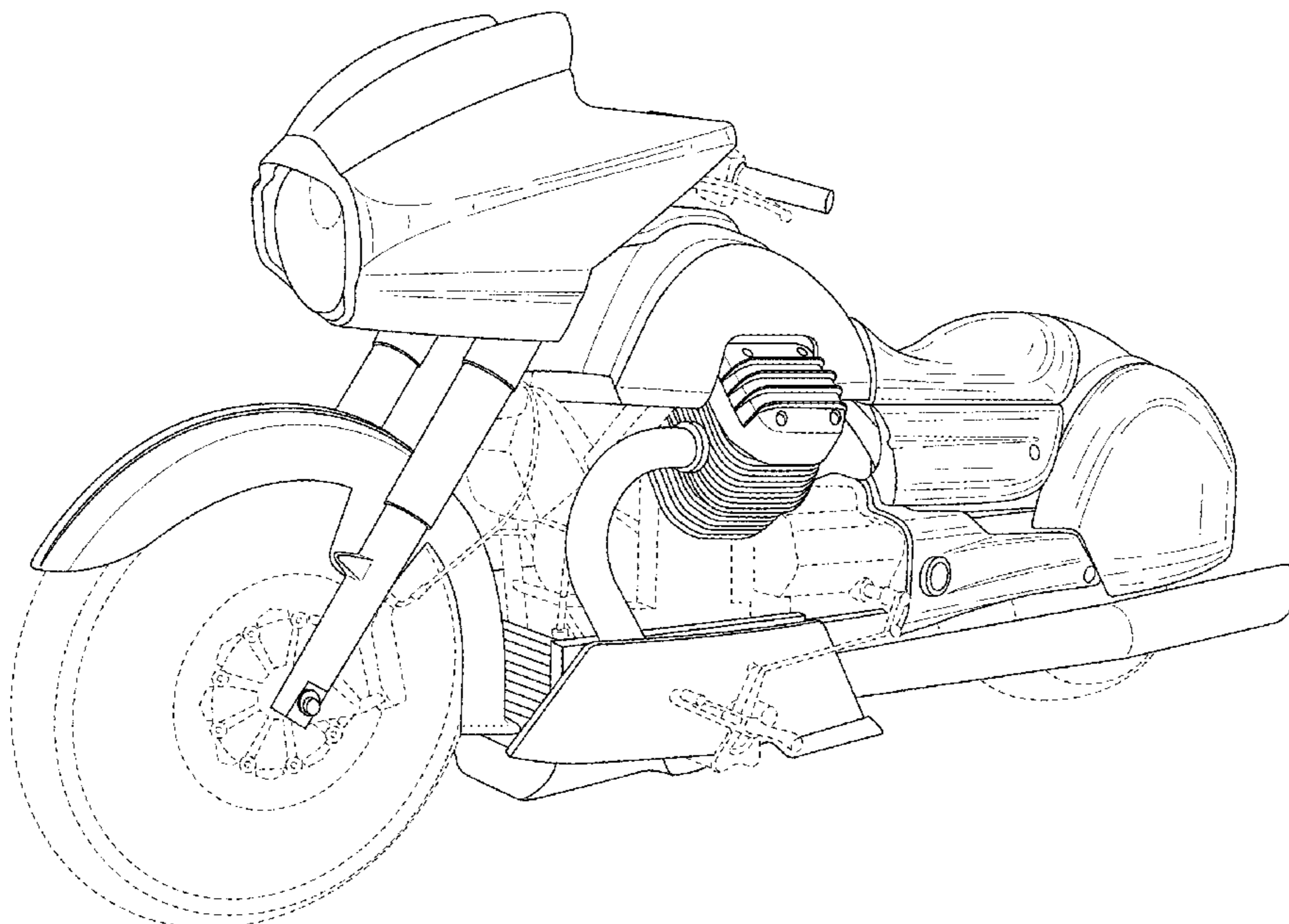

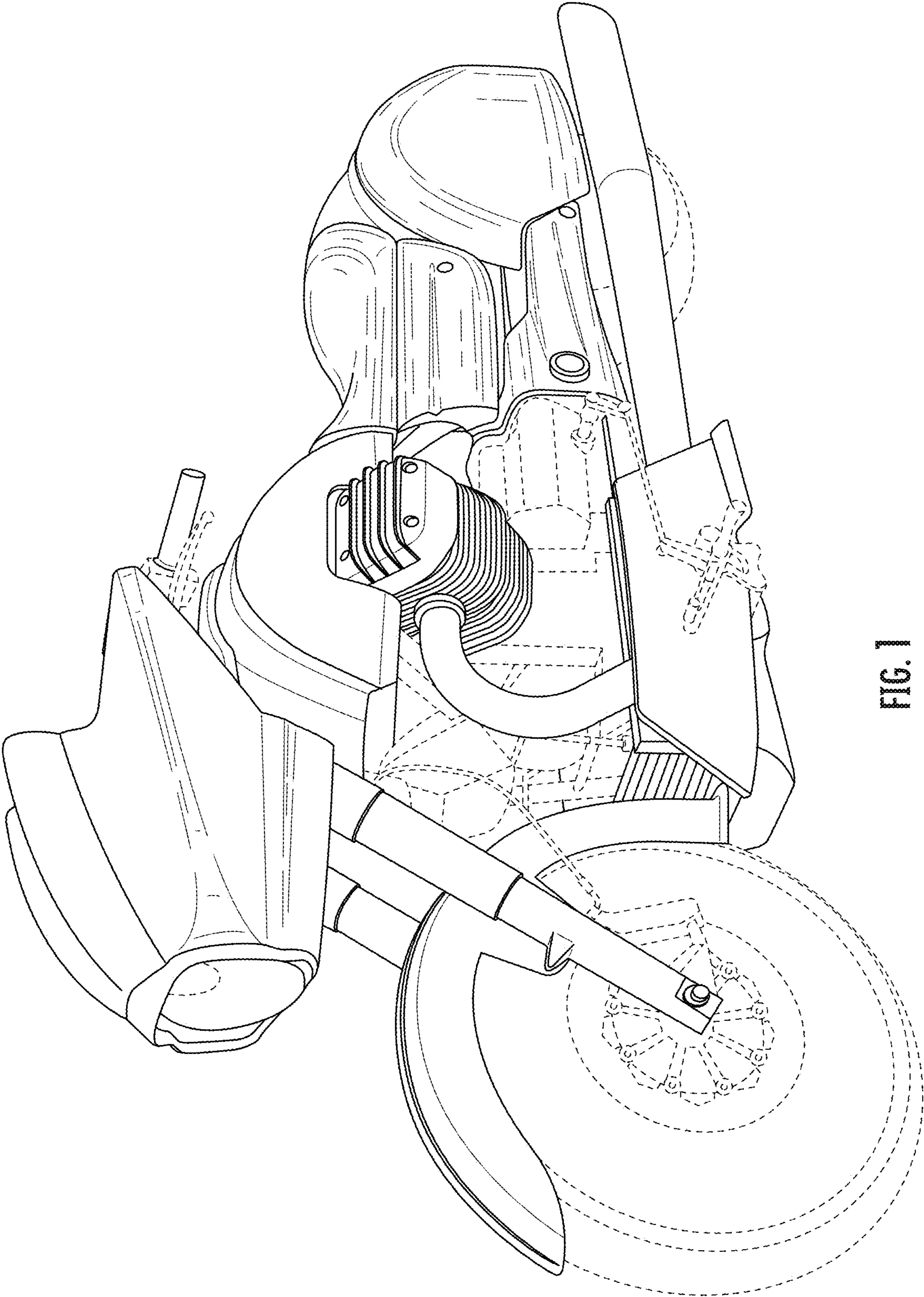

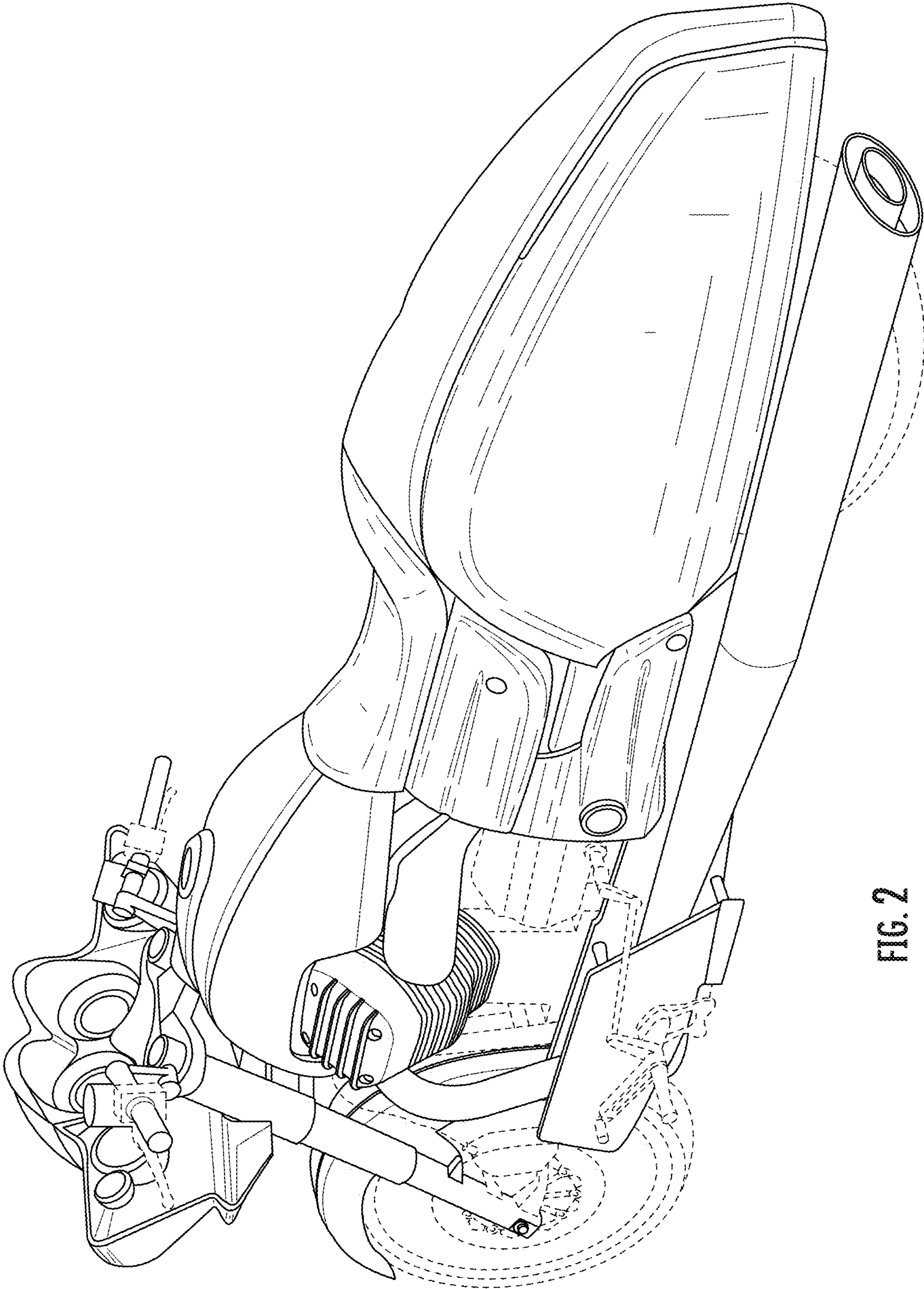

FIG. 2

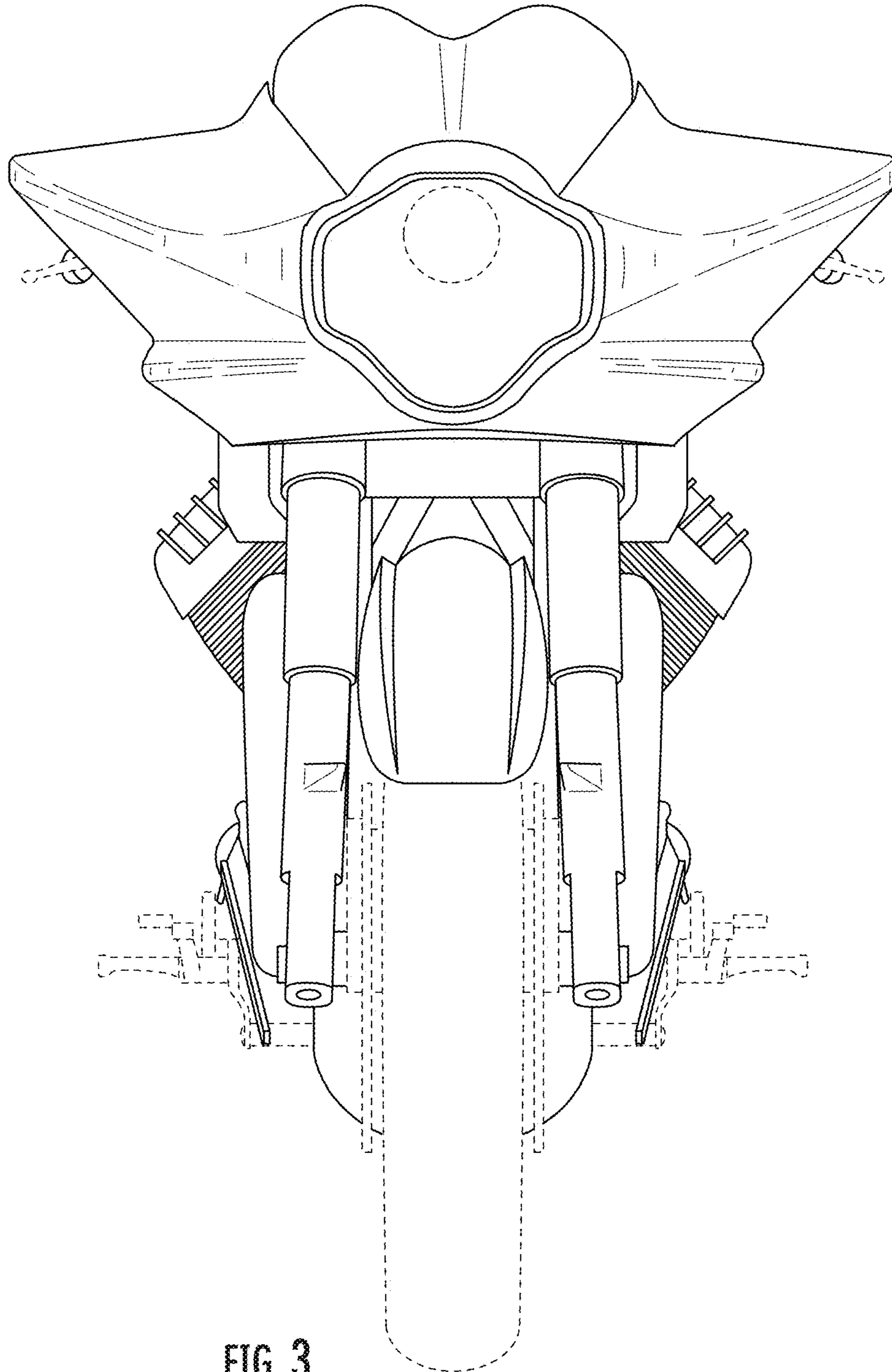

FIG. 3

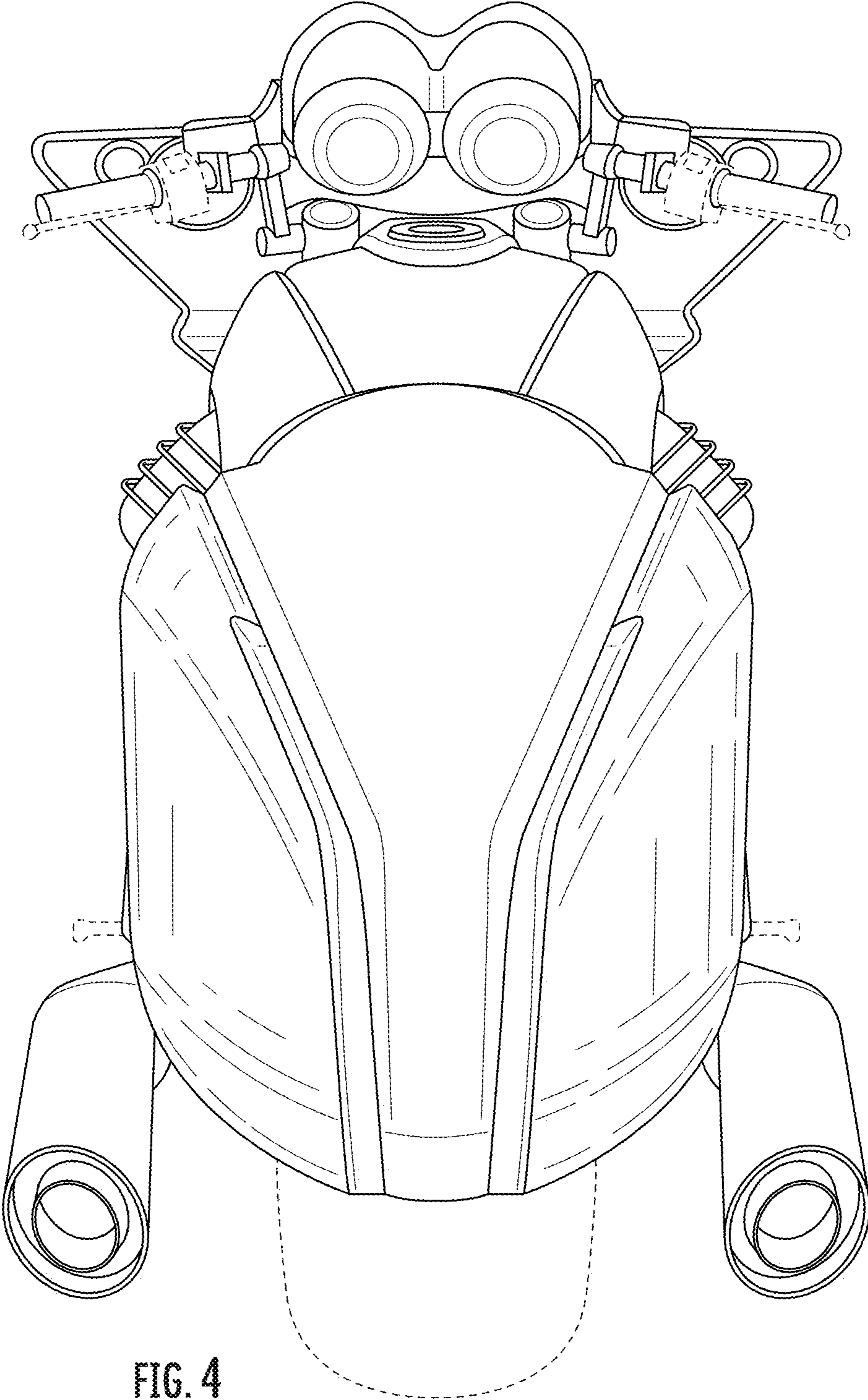

FIG. 4

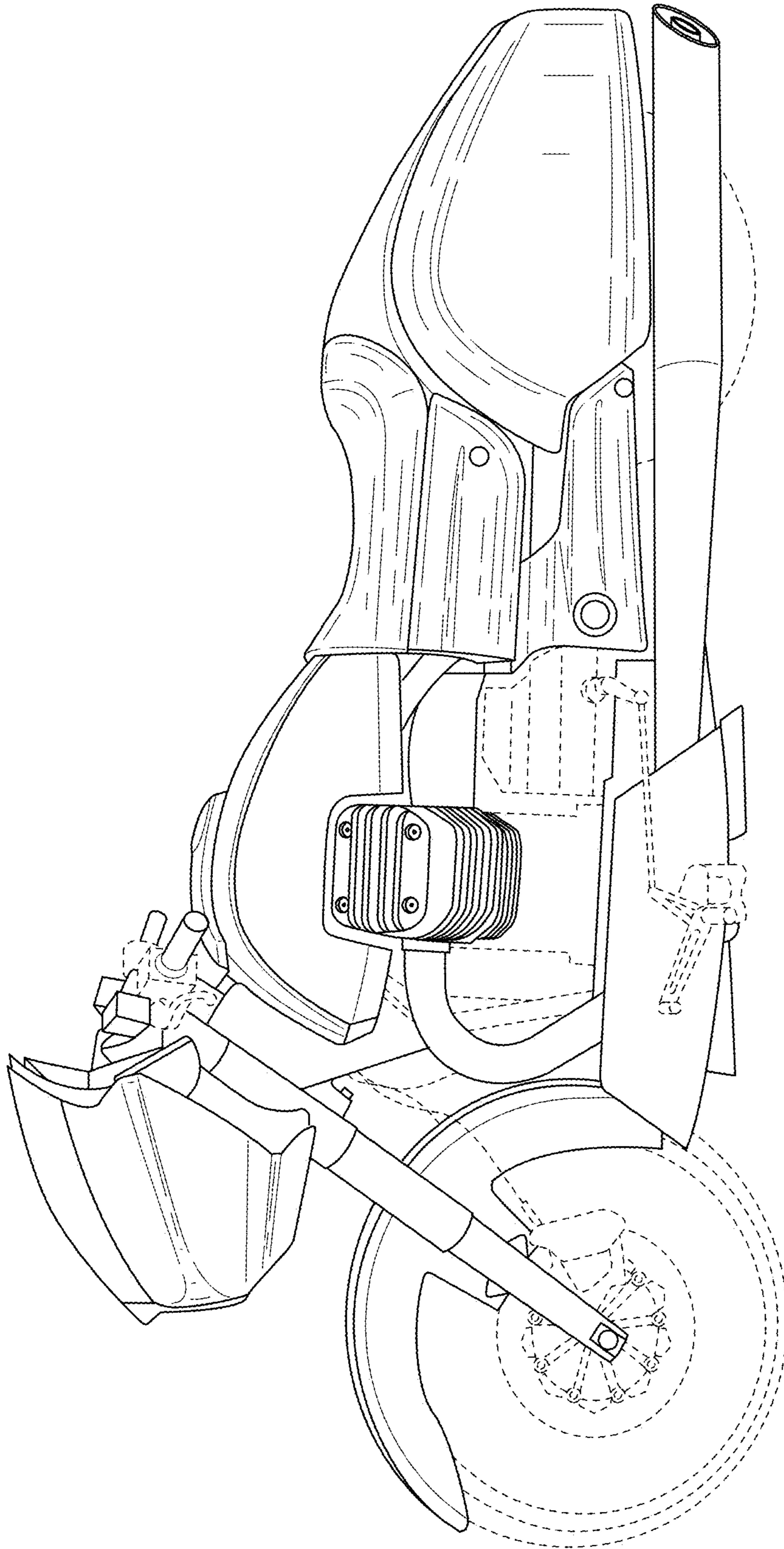

FIG. 5

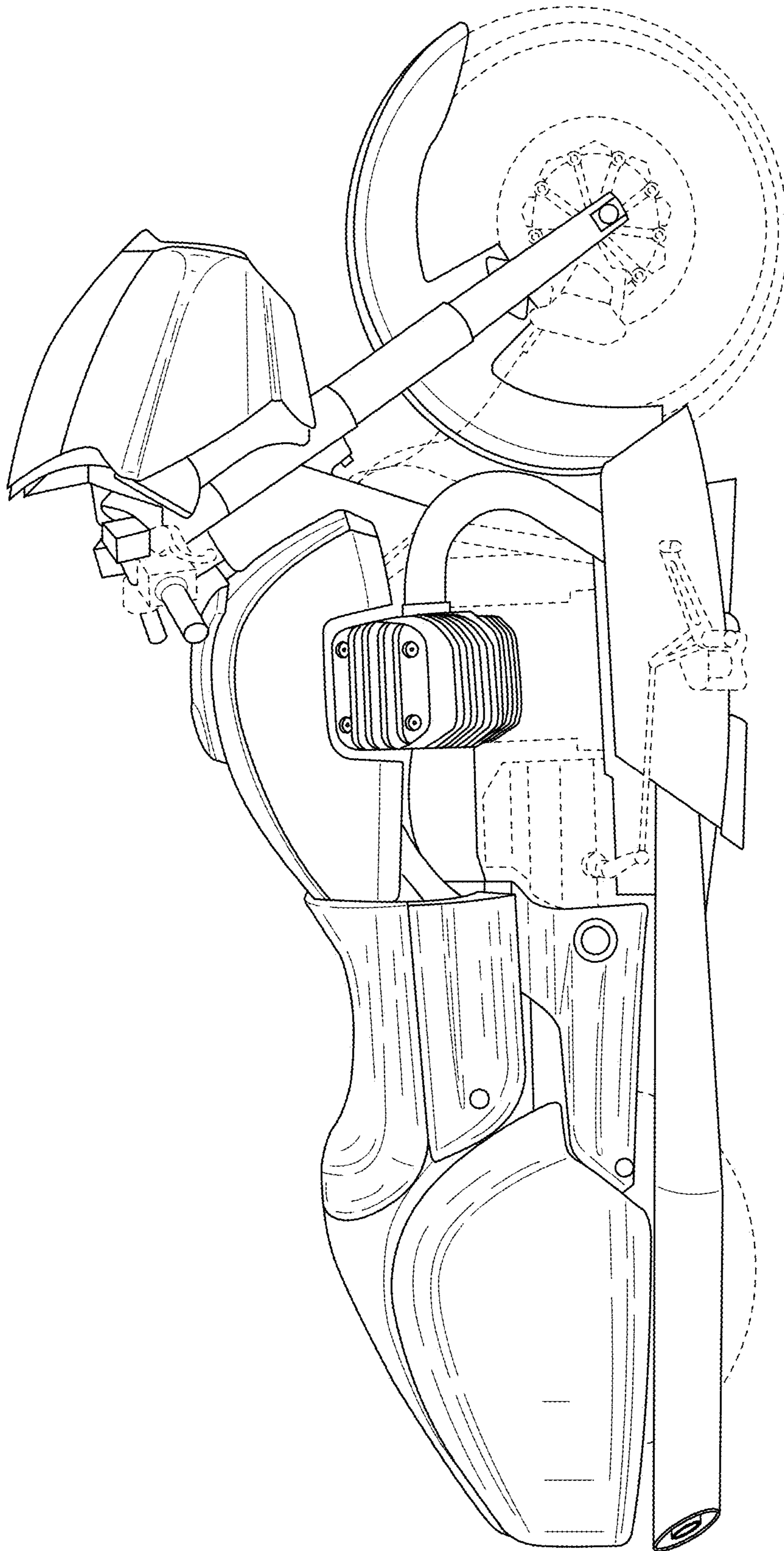

FIG. 6

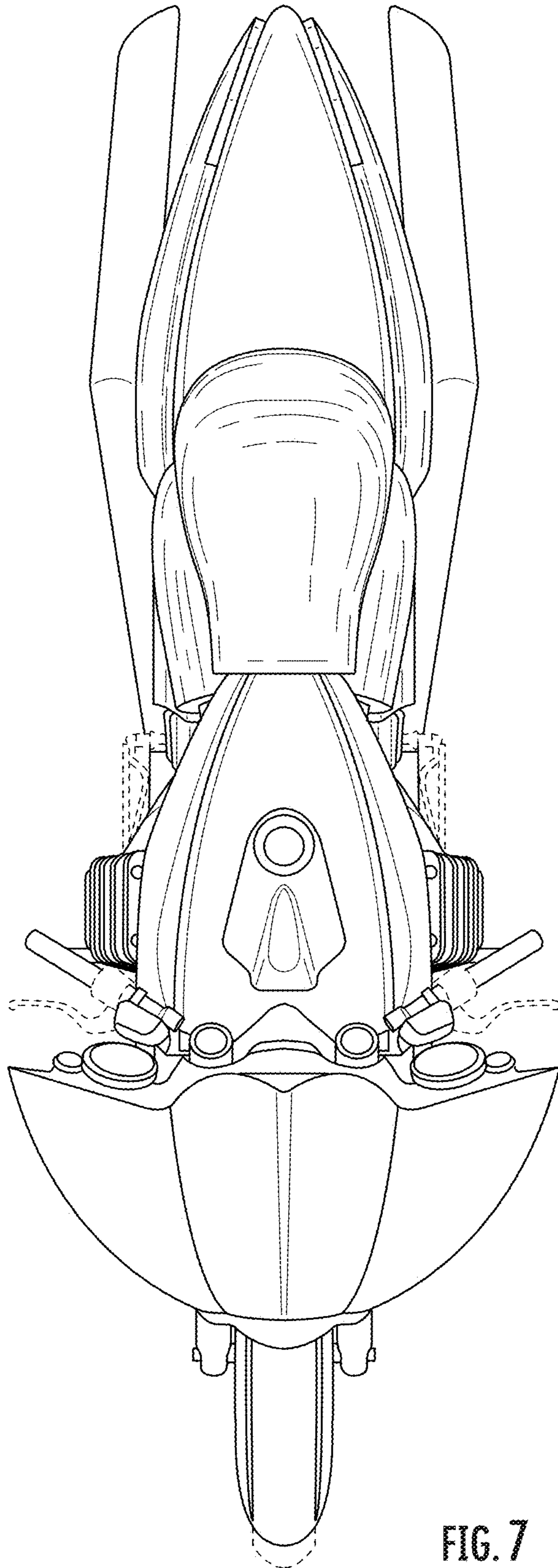

FIG. 7