



US00D879632S

(12) **United States Design Patent** (10) **Patent No.:** **US D879,632 S**  
**Tezuka et al.** (45) **Date of Patent:** **\*\* Mar. 31, 2020**

(54) **CLAMP SENSOR**

(71) Applicant: **HIOKI DENKI KABUSHIKI KAISHA**, Nagano (JP)

(72) Inventors: **Sayuri Tezuka**, Nagano (JP); **Manabu Senda**, Nagano (JP); **Kentaro Nakajima**, Nagano (JP)

(73) Assignee: **HIOKI DENKI KABUSHIKI KAISHA**, Nagano (JP)

(\*\*) Term: **15 Years**

(21) Appl. No.: **29/673,037**

(22) Filed: **Dec. 11, 2018**

(30) **Foreign Application Priority Data**

Jun. 12, 2018 (JP) ..... D2018-012854

(51) **LOC (12) Cl.** ..... **10-04**

(52) **U.S. Cl.**  
USPC ..... **D10/80**

(58) **Field of Classification Search**

USPC ..... D10/79, 80

CPC ..... G01R 1/04; G01R 1/0408; G01R 1/0416; G01R 1/0425; G01R 1/06; G01R 1/067; G01R 15/125; G01R 1/22; G01R 15/12; G01R 15/18; G01R 15/186; G01R 1/07; G01R 1/16772; G01R 1/16788; G01R 1/20; G01R 1/203; G01R 1/206; G01R 1/24; G01R 1/26; G01R 1/28; G01R 1/30; G01R 1/36; G01R 1/38; G01R 1/40; G01R 1/42; G01R 1/44; G01R 15/00; G01R 15/002; G01R 15/005; G01R 15/007; G01R 15/04; G01R 15/06; G01R 15/08; G01R 15/09; G01R 15/14; G01R 15/142; G01R 15/144; G01R 15/146; G01R 15/148; G01R 15/16; G01R 15/165; G01R 15/181; G01R 15/183; G01R 15/185; G01R 15/188; G01R 15/20; G01R 15/202; G01R 15/205; G01R 15/207; G01R 15/22;

G01R 15/24; G01R 15/241; G01R 15/242; G01R 15/243; G01R 15/245; G01R 15/246; G01R 15/247; G01R 15/248; G01R 15/26; G01R 31/04; G01R 31/041; G01R 31/043; G01R 31/045; G01R 29/24; G01R 29/18; G01R 29/12; F16B 2/22; H02G 3/26

See application file for complete search history.

(56) **References Cited**

U.S. PATENT DOCUMENTS

D396,657 S	8/1998	Nagai et al.	
D416,820 S	11/1999	Tanaka et al.	
D560,130 S	1/2008	Nagai et al.	
D636,689 S	4/2011	Laurino et al.	
D640,152 S	6/2011	Laurino et al.	
D665,282 S *	8/2012	Worones	..... D10/80
D678,790 S	3/2013	Worones	

(Continued)

*Primary Examiner* — Antoine Duval Davis

(74) *Attorney, Agent, or Firm* — Greenblum & Bernstein, P.L.C.

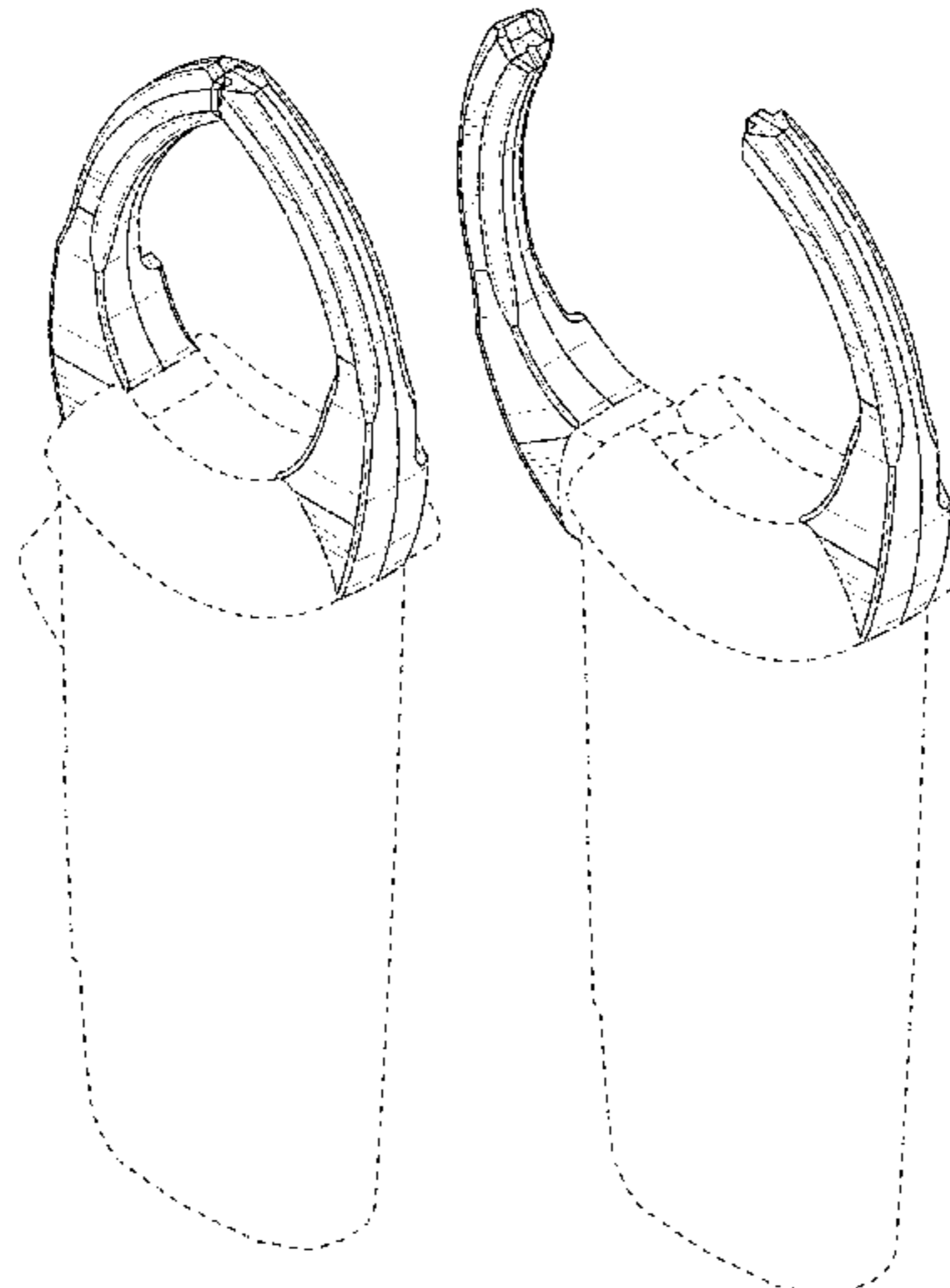
(57) **CLAIM**

We claim the ornamental design for a clamp sensor, as shown and described.

**DESCRIPTION**

FIG. 1 is a front elevational view of a clamp sensor, showing our new design;  
FIG. 2 is a rear elevational view thereof;  
FIG. 3 is a left side elevational view thereof;  
FIG. 4 is a right side elevational view thereof;  
FIG. 5 is a top plan view thereof;  
FIG. 6 is a bottom plan view thereof;  
FIG. 7 is a perspective view thereof, showing the clamp part closed; and,  
FIG. 8 is a perspective view thereof, showing the clamp part open.

**1 Claim, 8 Drawing Sheets**



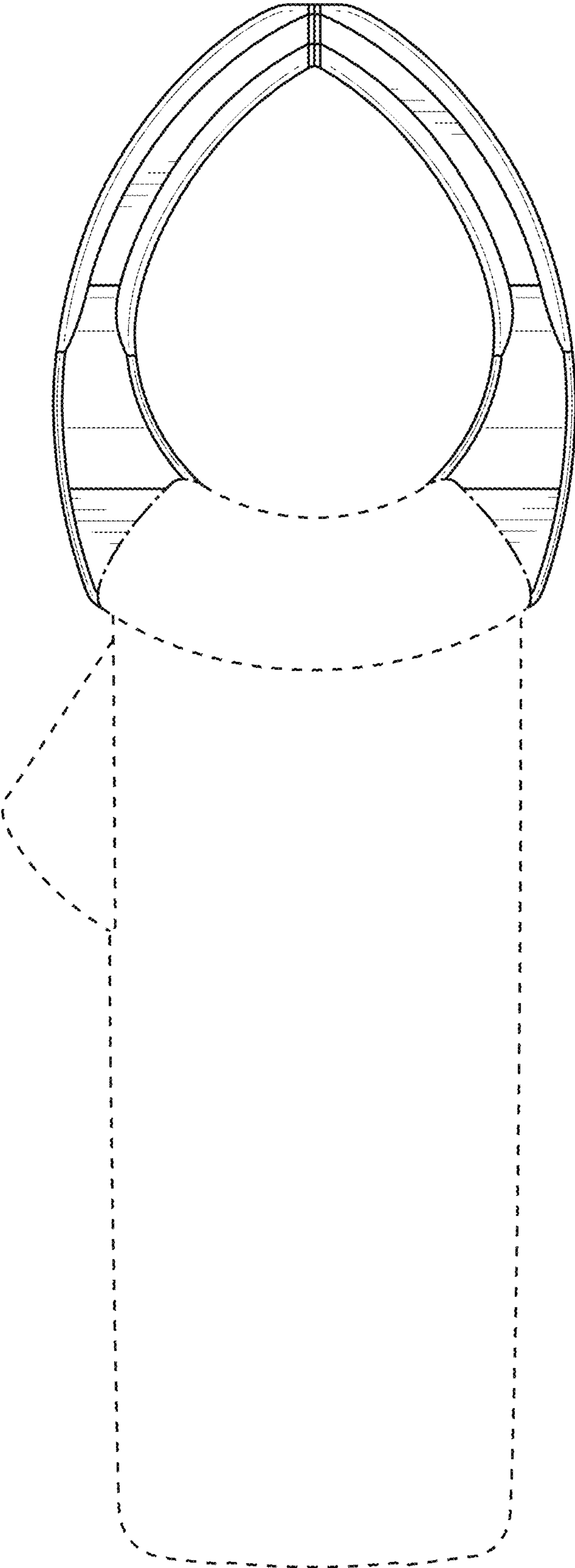
(56)

**References Cited**

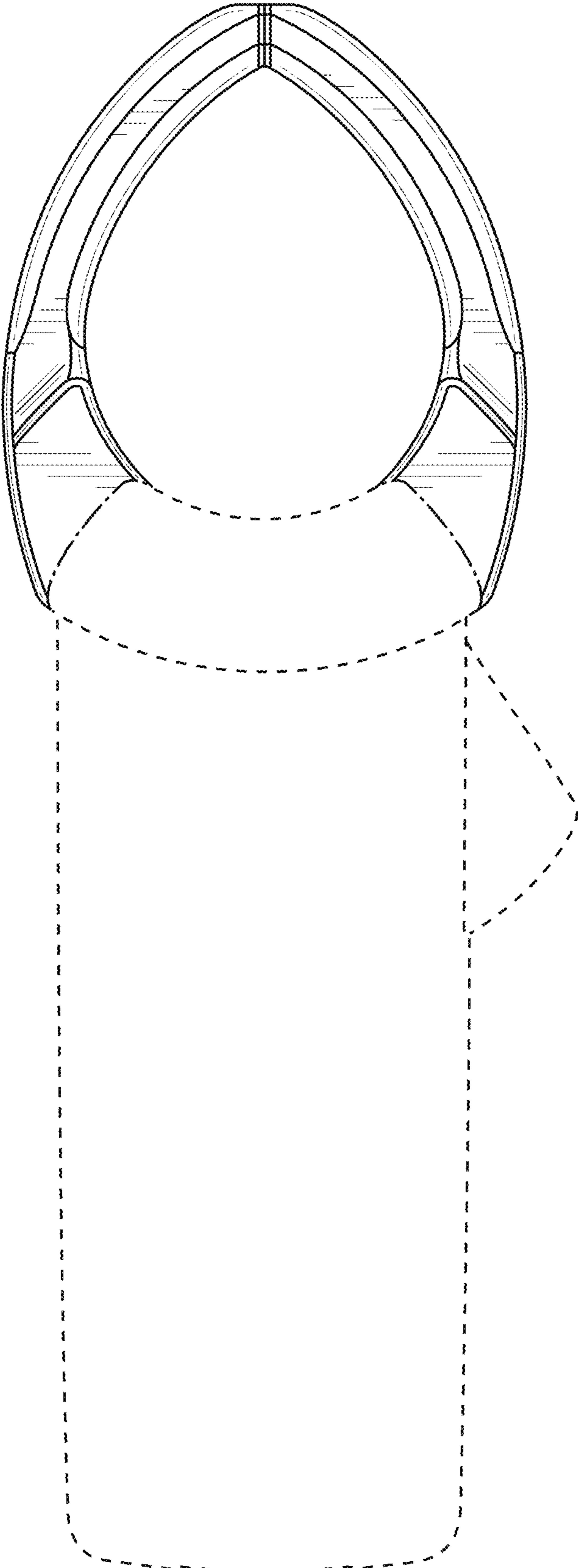
U.S. PATENT DOCUMENTS

D683,640 S	6/2013	Nagai et al.	
D684,074 S	6/2013	Wei	
D739,769 S *	9/2015	Shamir .....	D10/79
D762,502 S	8/2016	Shen	
D789,814 S	6/2017	Kodama et al.	
D802,456 S	11/2017	Huang	
D839,760 S *	2/2019	Hallam .....	D10/80
D842,148 S *	3/2019	Shen .....	D10/80

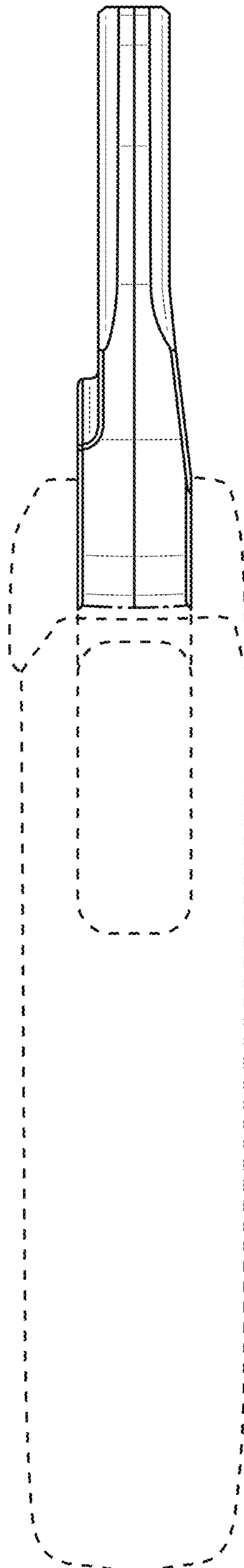
\* cited by examiner



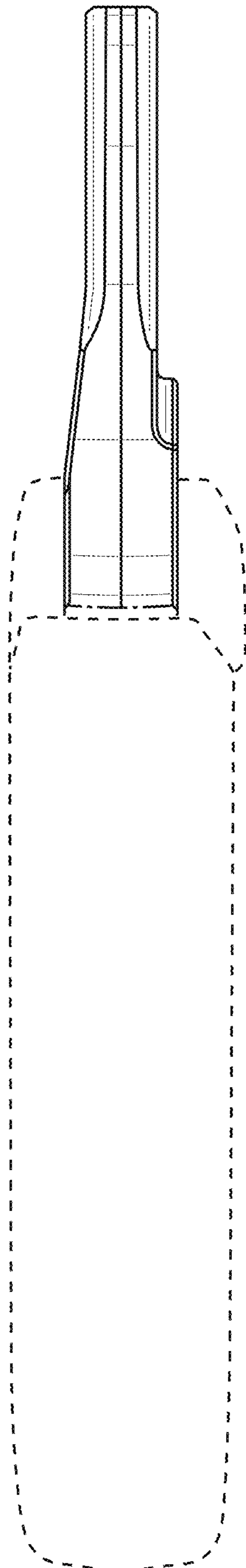
**FIG. 1**



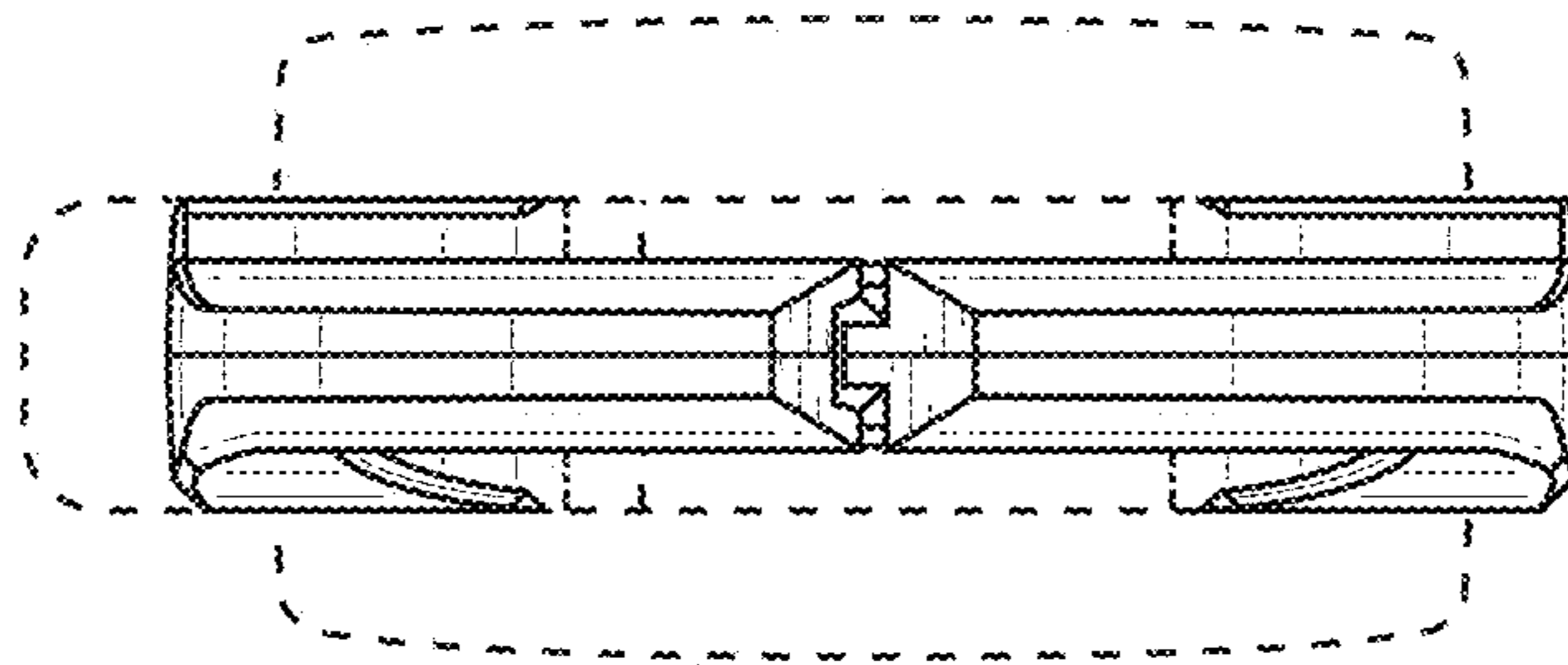
**FIG. 2**



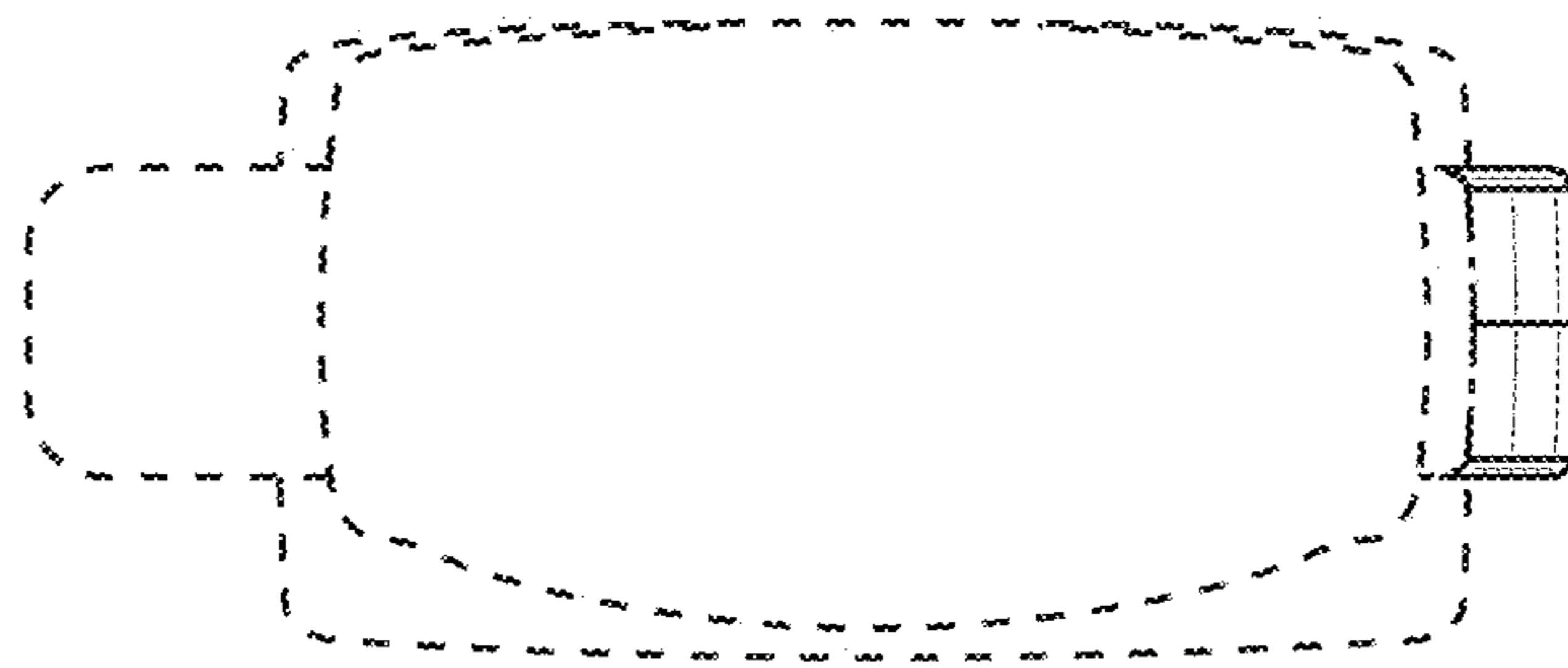
**FIG. 3**



**FIG. 4**

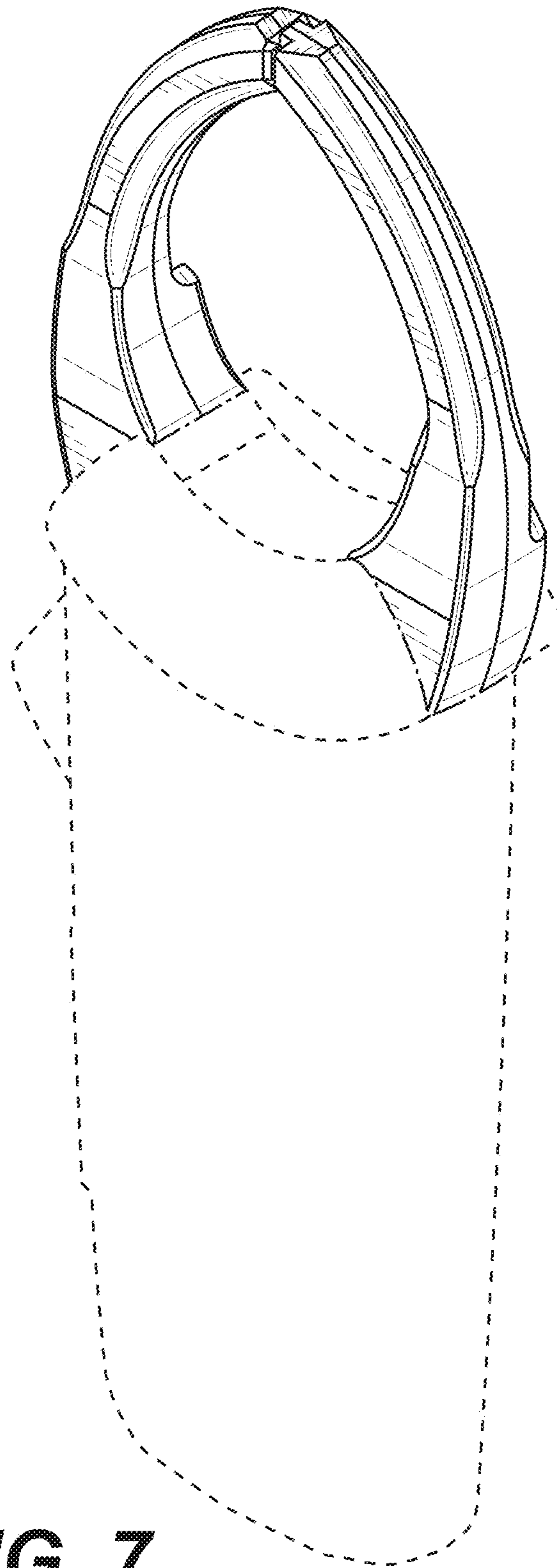


**FIG. 5**

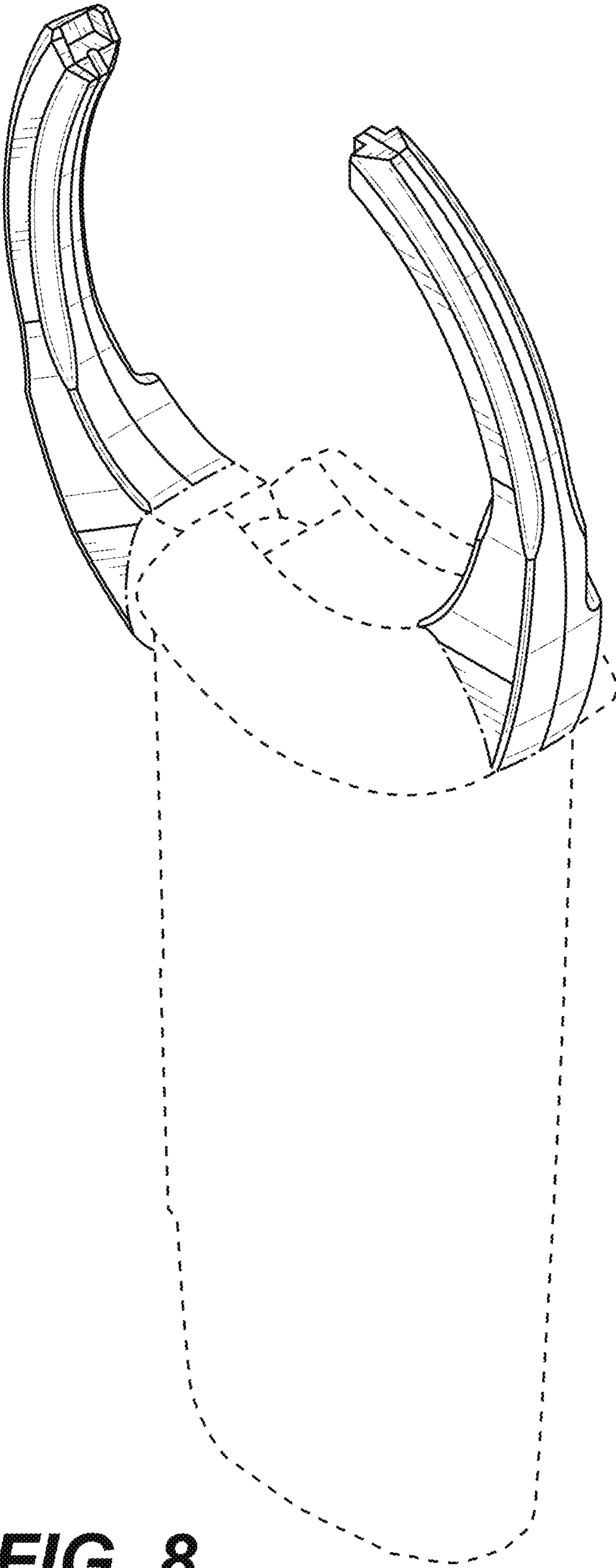


**FIG. 6**





**FIG. 7**



**FIG. 8**