



US00D879248S

(12) **United States Design Patent** (10) **Patent No.:** **US D879,248 S**  
**Shigyou et al.** (45) **Date of Patent:** **\*\* Mar. 24, 2020**

(54) **FLUID CONTROL VALVE UNIT**

(56) **References Cited**

(71) Applicant: **FUJIKIN INCORPORATED**,  
Osaka-shi (JP)  
(72) Inventors: **Kohei Shigyou**, Osaka (JP); **Takashi Hirose**, Osaka (JP); **Kouji Nishino**, Osaka (JP); **Ryousuke Dohi**, Osaka (JP); **Naofumi Yasumoto**, Osaka (JP)

U.S. PATENT DOCUMENTS

D295,180 S 4/1988 Kanno  
4,854,348 A 8/1989 Tochikubo  
5,603,355 A 2/1997 Miyazoe et al.  
D461,733 S \* 8/2002 Iida ..... D10/85  
6,701,959 B1 3/2004 Flynn et al.

(Continued)

(73) Assignee: **FUJIKIN INCORPORATED**,  
Osaka-Shi (JP)

OTHER PUBLICATIONS

Office Action with Form PTO-892 Notice of References Cited issued by the United States Patent and Trademark Office for the parent U.S. Appl. No. 35/501,742, dated Feb. 20, 2018.

(Continued)

(\*\*) Term: **15 Years**

*Primary Examiner* — Mary Ann Calabrese

(21) Appl. No.: **29/633,491**

(74) *Attorney, Agent, or Firm* — Mori & Ward, LLP

(22) Filed: **Jan. 15, 2018**

**Related U.S. Application Data**

(62) Division of application No. 35/501,742, filed on Apr. 20, 2016 (U.S. filing date under 35 U.S.C. 384), and having an international filing date of Apr. 20, 2016, now Pat. No. Des. 820,394.

(57) **CLAIM**

The ornamental design for a fluid control valve unit, as shown and described.

**DESCRIPTION**

(30) **Foreign Application Priority Data**

Oct. 30, 2015 (JP) ..... 2015-024300  
Oct. 30, 2015 (JP) ..... 2015-024301

(51) **LOC (12) Cl.** ..... **23-01**

(52) **U.S. Cl.**  
USPC ..... **D23/233**

(58) **Field of Classification Search**  
USPC ..... D23/233, 235-237; D10/85  
CPC . F16K 1/00; F16K 1/12; F16K 3/0209; F16K 11/00; F16K 11/027; F16K 11/044; F16K 11/07; F16K 11/078; F16K 11/20; F16K 15/00; F16K 15/02; F16K 15/06; F16K 21/00; F16K 21/02; F16K 27/00; E03C 1/08

FIG. 1 shows a front, top and right perspective view of the design;  
FIG. 2 shows a back, bottom and left perspective view of the design;  
FIG. 3 is an enlarged front view of a left side portion of FIG. 1;  
FIG. 4 is an enlarged back view of a right side portion of FIG. 2;  
FIG. 5 is an enlarged cross-section top view taken along line V-V in FIG. 3;  
FIG. 6 is a cross-sectional right view taken along line VI-VI in FIG. 3; and,  
FIG. 7 shows a front view of the design.  
The broken lines show portions of the fluid control valve unit that form no part of the claimed design.

See application file for complete search history.

**1 Claim, 7 Drawing Sheets**

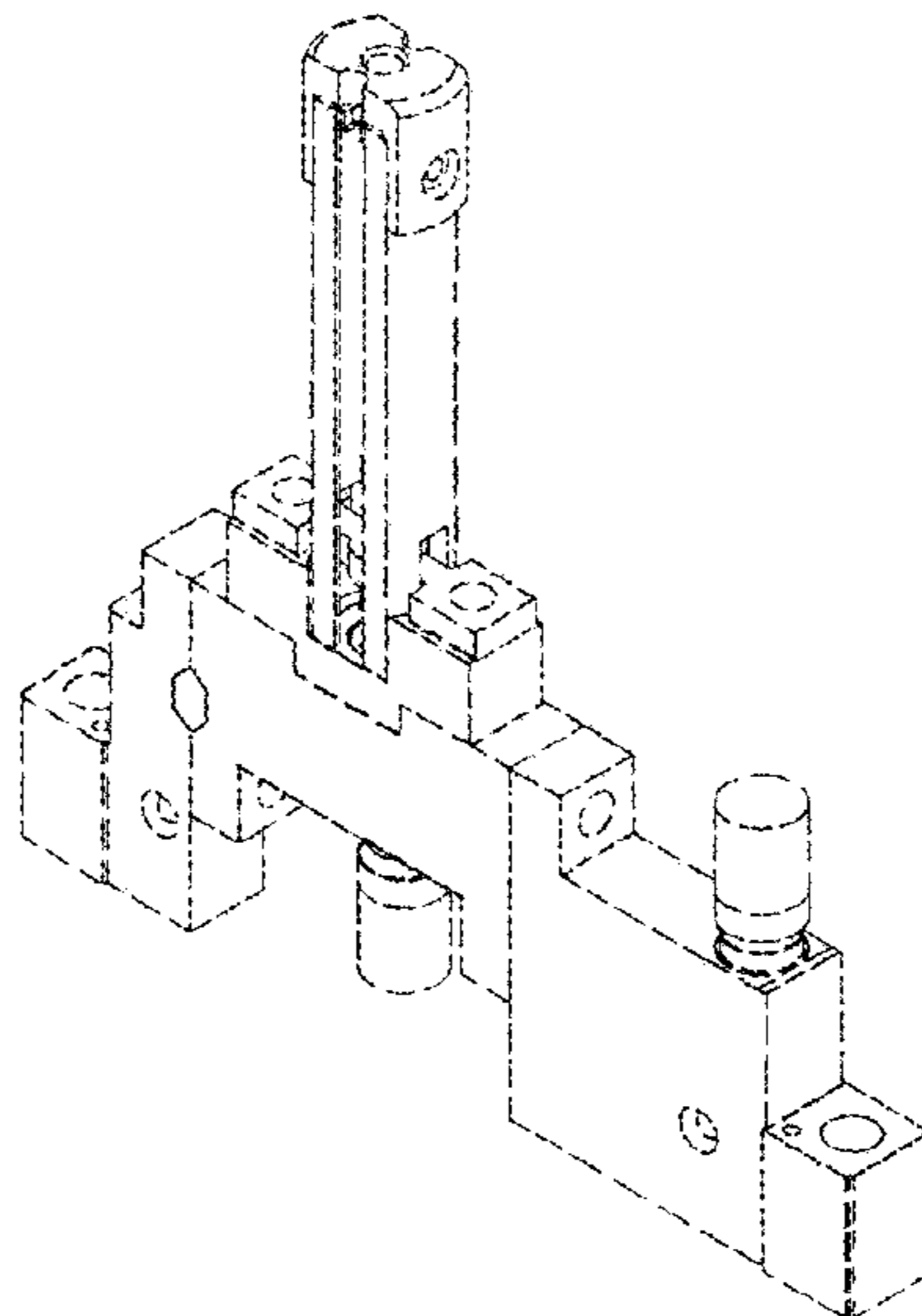

(56)

**References Cited**

U.S. PATENT DOCUMENTS

D606,168 S 12/2009 Miyazoe  
D623,270 S 9/2010 Fukano et al.  
D653,307 S 1/2012 Senba  
D653,308 S 1/2012 Senba  
8,109,449 B2 \* 2/2012 Weis ..... E03C 1/08  
239/428.5  
D665,874 S 8/2012 Senba  
D681,163 S \* 4/2013 Asaba ..... D10/85  
D690,392 S \* 9/2013 Miyazoe ..... D23/233  
8,733,389 B2 5/2014 Hong et al.  
D716,911 S \* 11/2014 Faraon Chaul Huerta .. D23/233  
D720,430 S \* 12/2014 Yoshida ..... E03C 1/08  
D23/233  
D745,114 S \* 12/2015 Alexander ..... D23/235  
9,309,983 B2 4/2016 Yogo et al.  
2004/0040603 A1 3/2004 Shieh  
2016/0362239 A1 12/2016 Johnson

OTHER PUBLICATIONS

Office Action issued by the United States Patent and Trademark Office for the parent U.S. Appl. No. 35/501,742, dated Mar. 13, 2018.

\* cited by examiner

FIG. 1

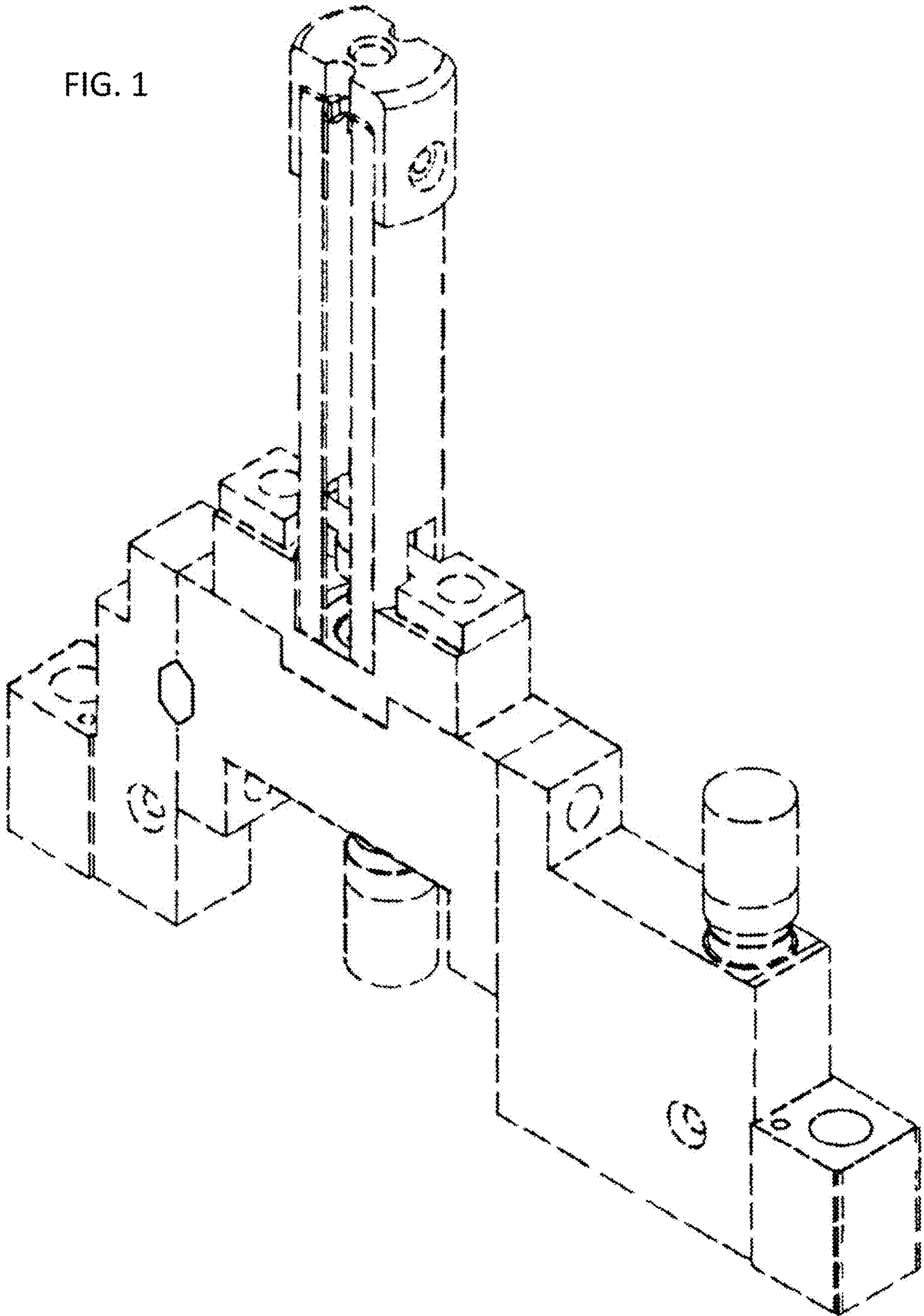

FIG. 2

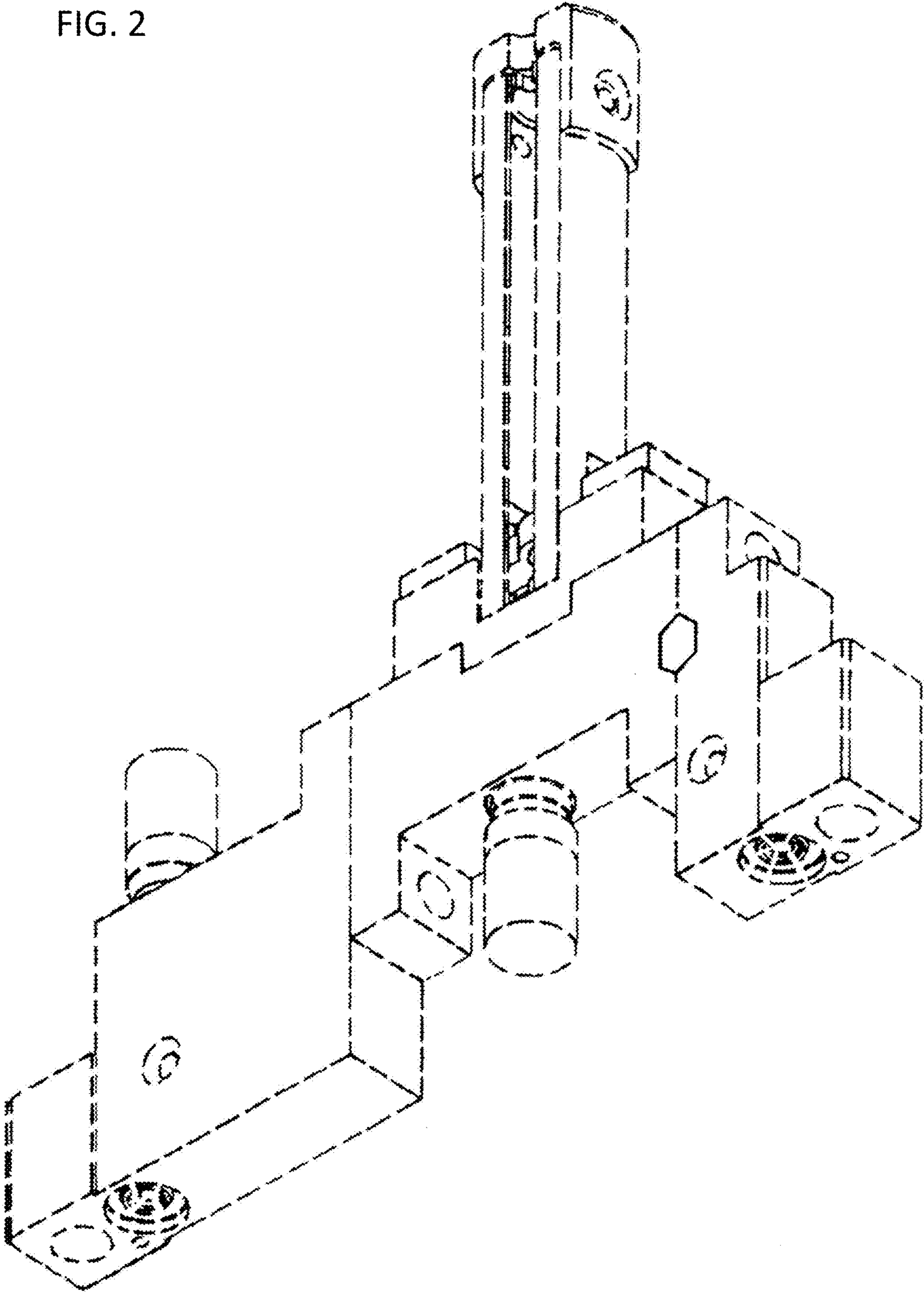





FIG. 4

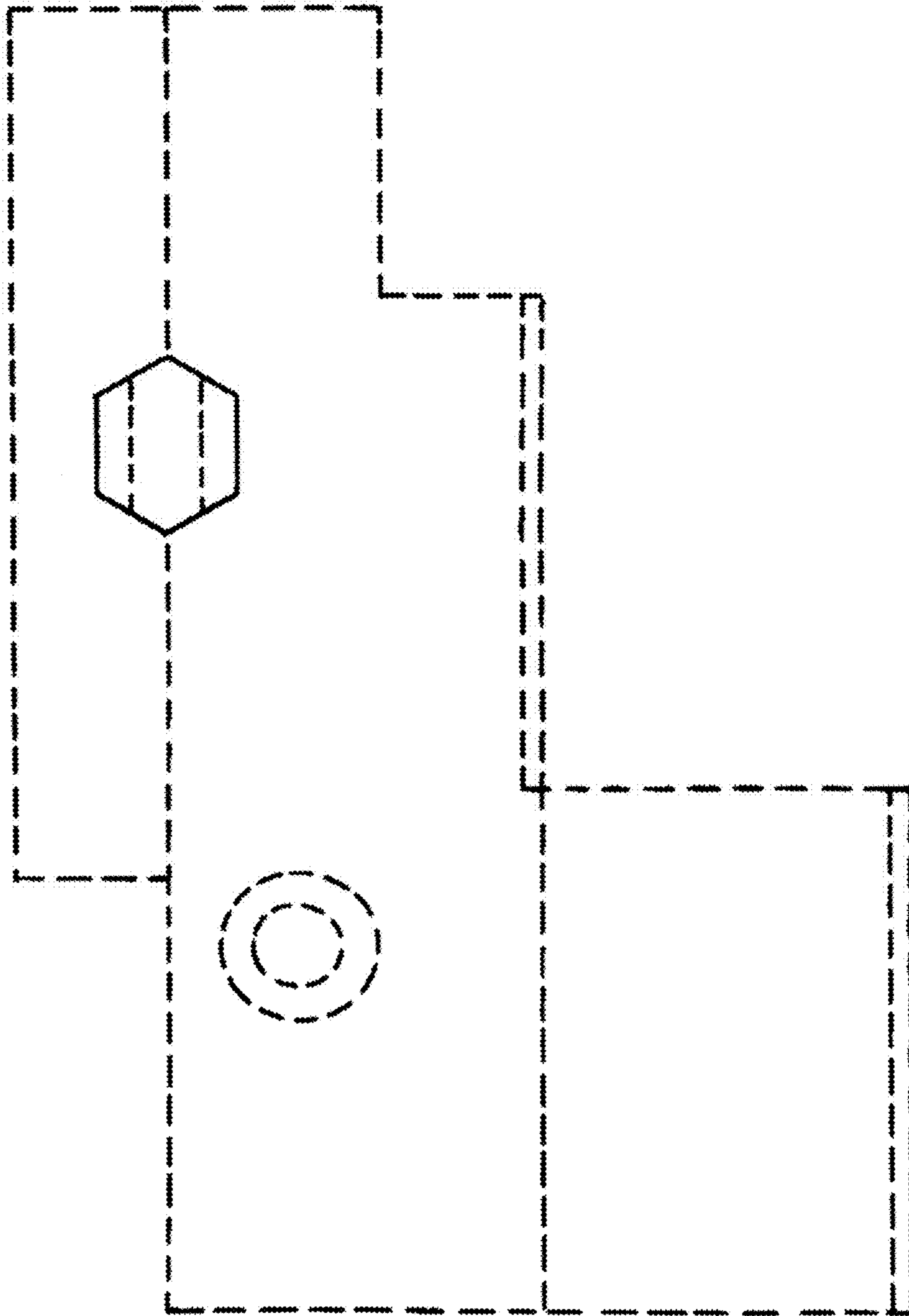

FIG. 5

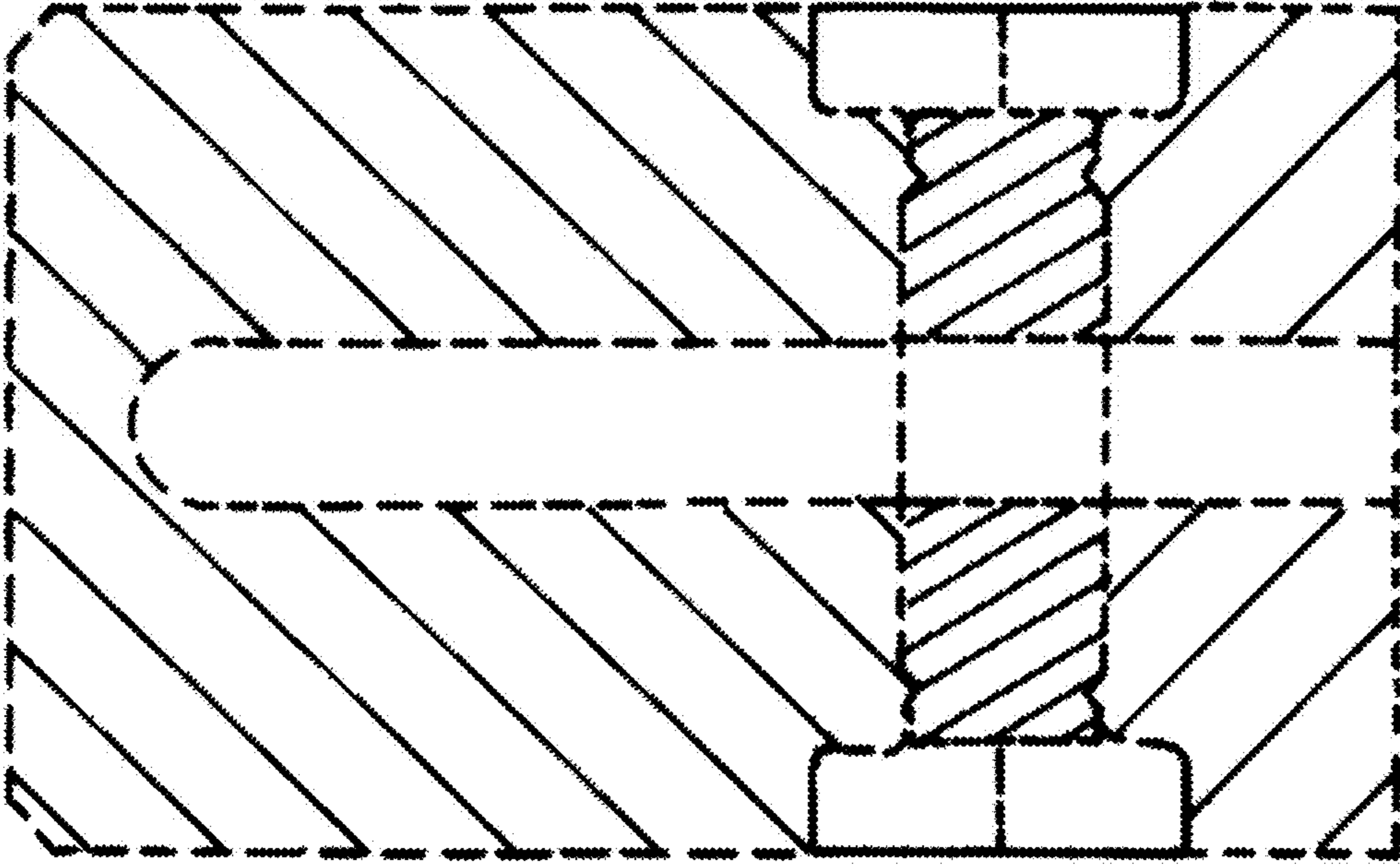

FIG. 6

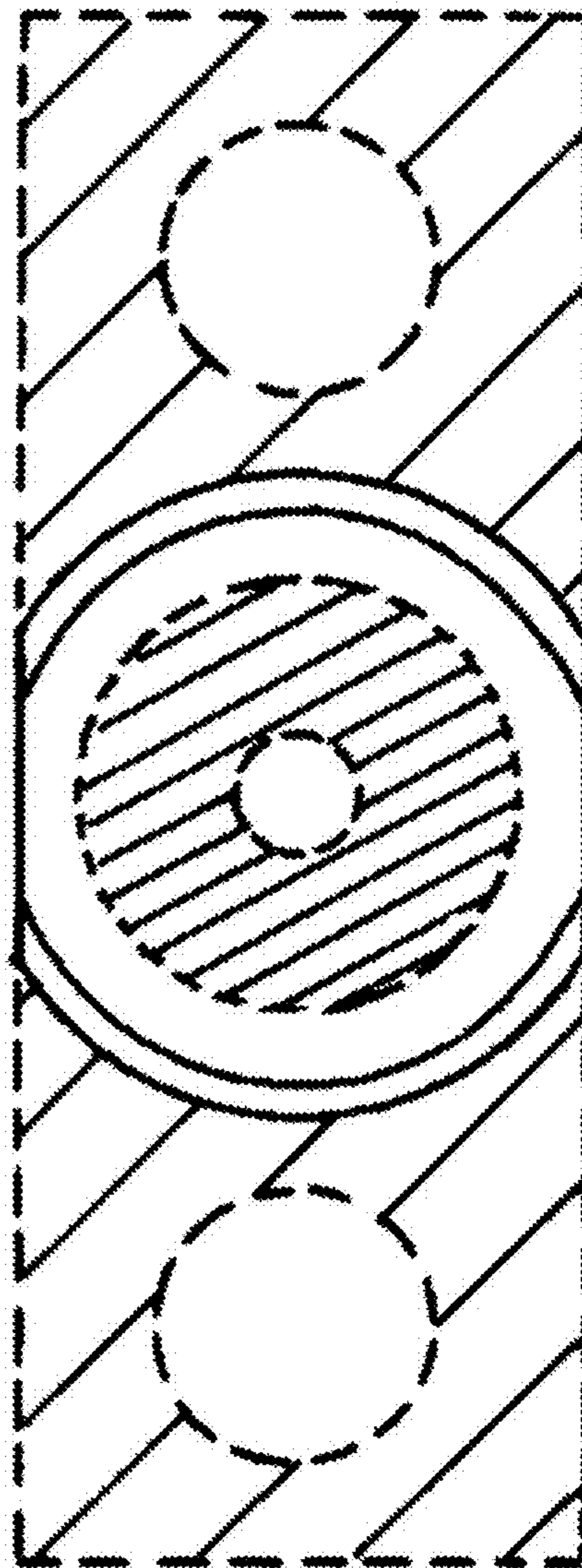



FIG. 7

