



US00D879040S

(12) **United States Design Patent**  
**Moule**

(10) **Patent No.:** **US D879,040 S**  
(45) **Date of Patent:** **\*\* Mar. 24, 2020**

(54) **ELECTRICAL CONNECTION BOX**

FOREIGN PATENT DOCUMENTS

(71) Applicant: **Electro Expo Limited**, Potters Bar,  
Hertfordshire (GB)

GB 2260864 A \* 4/1993 ..... H01R 9/223

(72) Inventor: **Peter John Moule**, Potters Bar (GB)

OTHER PUBLICATIONS

(73) Assignee: **Electro Expo Limited**, Potters Bar  
(GB)

Terminal Box Chochox Chochox by Chochox, dated Apr. 28, 2012,  
[online], [site visited Aug. 16, 2019]. Available from Internet, URL:  
<https://www.amazon.co.uk/TERMINAL-BOX-CHOCBOX/dp/B0118JNYBS> (Year: 2012).\*

(\*\*) Term: **15 Years**

(Continued)

(21) Appl. No.: **29/665,427**

*Primary Examiner* — Angela J Lee

(22) Filed: **Oct. 3, 2018**

*Assistant Examiner* — Shawn T Gingrich

(30) **Foreign Application Priority Data**

(74) *Attorney, Agent, or Firm* — Seed IP Law Group LLP

Apr. 3, 2018 (GB) ..... 6032300  
Apr. 3, 2018 (GB) ..... 6032301

(57) **CLAIM**

(51) **LOC (12) Cl.** ..... **13-03**

The ornamental design for an electrical connection box, as shown and described.

(52) **U.S. Cl.**

USPC ..... **D13/133; D13/152**

(58) **Field of Classification Search**

USPC ..... D13/118-123, 133, 146, 147, 149,  
D13/151-156, 173, 184, 199

CPC ... H01R 4/48; H01R 9/05; H01R 9/22; H01R  
12/00; H01R 13/00; H01R 13/44; H01R  
13/62; H01R 13/66; H02G 3/08; H02G  
3/14; H02G 3/16; H02G 3/18; H05K  
5/00; H05K 5/02; H05K 7/20; B65D  
85/20; G02B 6/44; H04M 1/00

See application file for complete search history.

**DESCRIPTION**

FIG. 1 is a front perspective view of an electrical connection box in an open position showing my new design.

FIG. 2 is a top plan view thereof.

FIG. 3 is a right side elevational view thereof.

FIG. 4 is a front elevational view thereof.

FIG. 5 is a bottom plan view thereof.

FIG. 6 is a front perspective view of the electrical connection box of FIG. 1 in a closed position showing my new design.

FIG. 7 is a rear perspective thereof.

FIG. 8 is a left perspective view thereof.

FIG. 9 is a bottom perspective view thereof.

FIG. 10 is a right perspective view thereof; and,

FIG. 11 is a bottom plan view thereof.

The broken lines in the drawings show portions of the article that form no part of the claimed design.

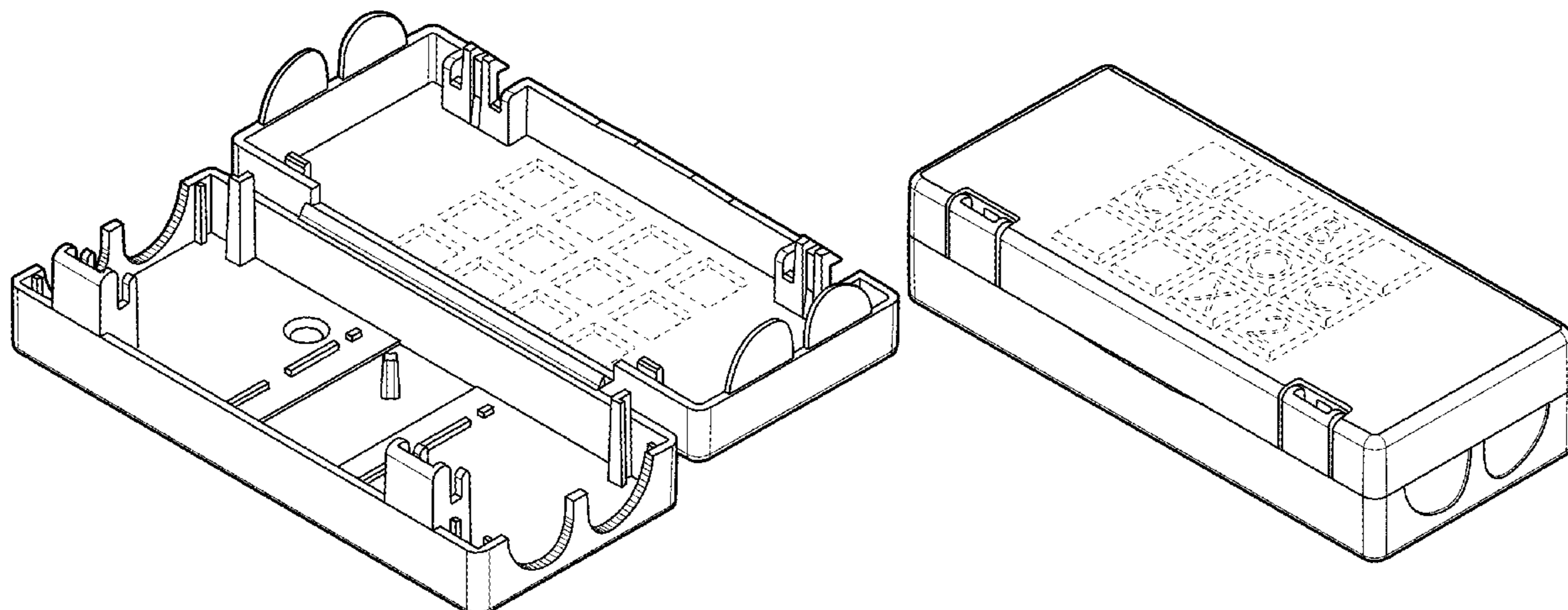
(56) **References Cited**

U.S. PATENT DOCUMENTS

609,356 A \* 8/1898 Krantz ..... H02G 3/14  
220/3.8  
D188,850 S \* 9/1960 Clark ..... D14/256  
D312,244 S \* 11/1990 Collins ..... D13/152  
D333,654 S \* 3/1993 Aris ..... D13/156  
D337,993 S \* 8/1993 Garthwaite ..... D13/156

(Continued)

**1 Claim, 11 Drawing Sheets**



(56)

**References Cited**

U.S. PATENT DOCUMENTS

D410,435 S \* 6/1999 Hambleton ..... D13/156  
 6,028,268 A \* 2/2000 Stark ..... H02B 1/50  
 174/67  
 6,309,234 B1 \* 10/2001 Hattori ..... H01R 31/08  
 430/507  
 6,806,426 B1 \* 10/2004 Gretz ..... H02G 3/14  
 174/481  
 D545,765 S \* 7/2007 Cockburn ..... D13/147  
 7,431,594 B2 \* 10/2008 Castaldo ..... H01R 13/6395  
 174/67  
 D738,413 S \* 9/2015 Randlov ..... D15/143  
 D783,537 S \* 4/2017 Skov ..... D13/147  
 2008/0110661 A1 \* 5/2008 Dinh ..... H01R 13/5213  
 174/53  
 2009/0211778 A1 \* 8/2009 Drane ..... H02G 3/14  
 174/67  
 2010/0078189 A1 \* 4/2010 Leopold ..... H02G 3/088  
 174/50.5

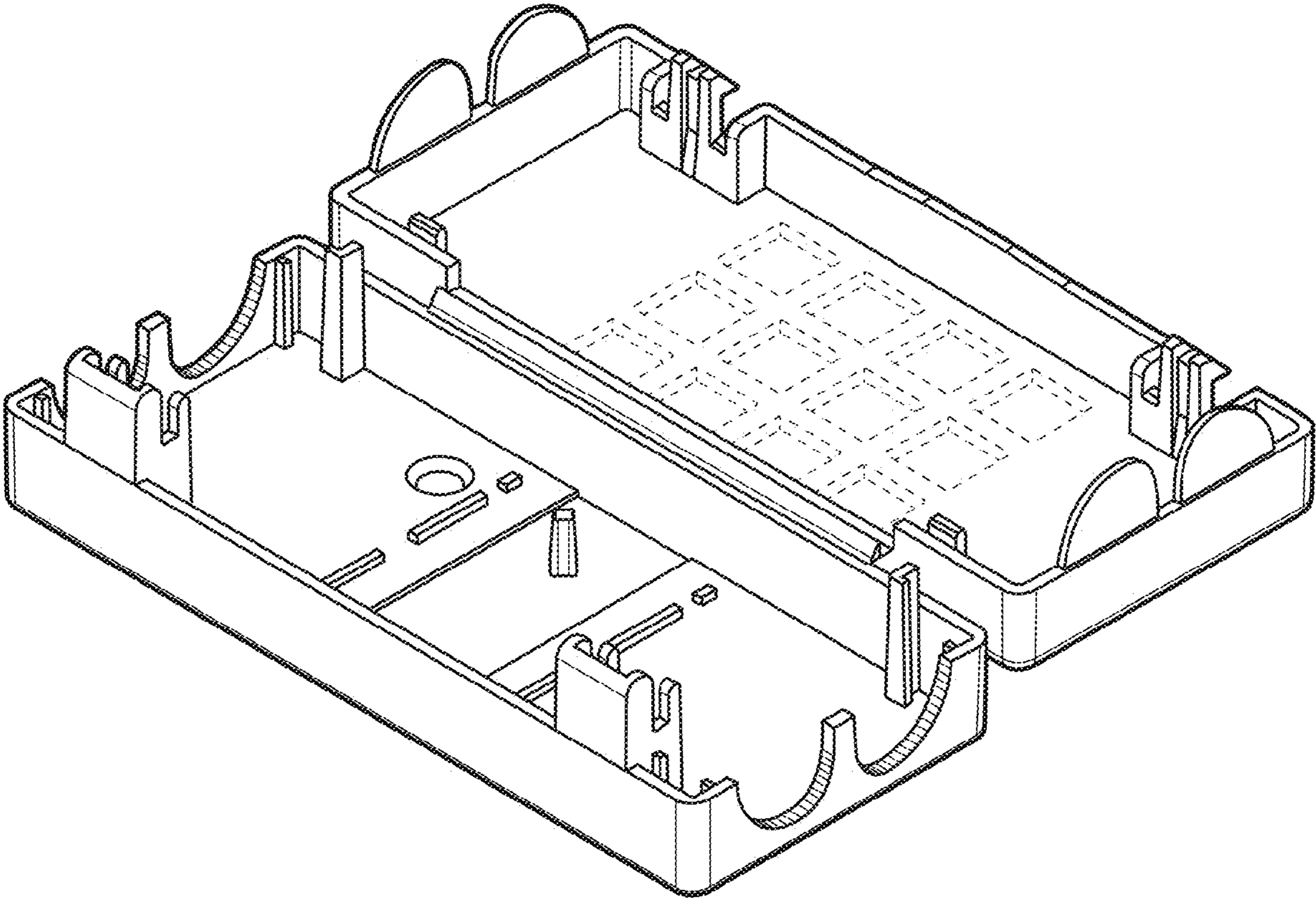
2010/0142899 A1 \* 6/2010 Zhou ..... G02B 6/4466  
 385/88  
 2010/0173511 A1 \* 7/2010 Giefers ..... H01R 4/489  
 439/329  
 2017/0332498 A1 \* 11/2017 Larsson ..... H02G 3/086  
 2019/0067923 A1 \* 2/2019 Kanamori ..... H02G 3/081

OTHER PUBLICATIONS

Chocbox In-Line Connector / Junction Box Clear, dated Jan. 23, 2012, [online], [site visited Aug. 16, 2019]. Available from Internet, URL: <https://www.amazon.co.uk/Chocbox-Line-Connector-Junction-Clear/dp/B0070XCJZE> (Year: 2012).\*

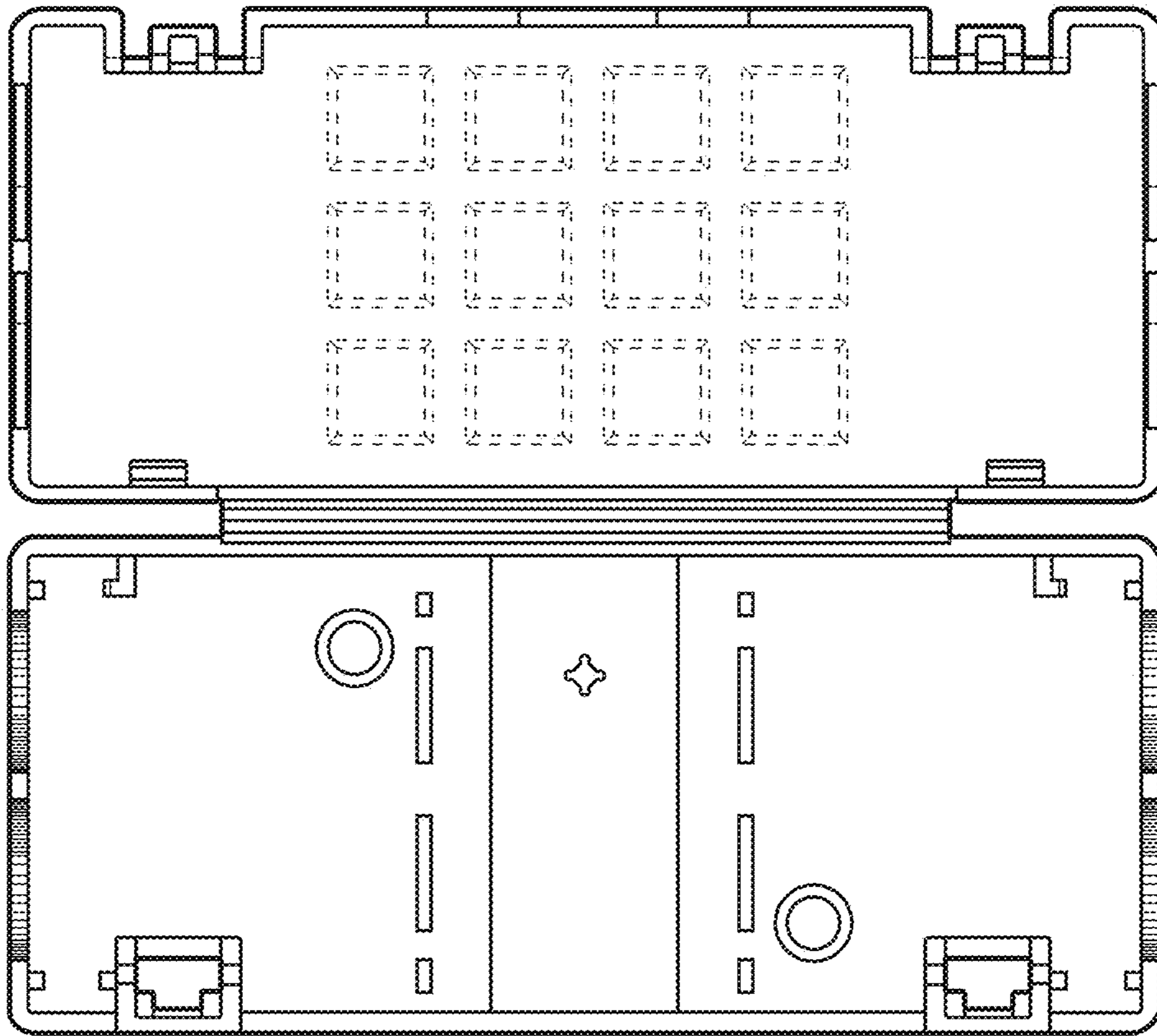
Grandfather's bright spark nets £25m deal on Dragon's Den, dated Dec. 12, 2007, [online], [site visited Aug. 16, 2019]. Available from Internet, URL: <https://www.dailymail.co.uk/news/article-501208/Grandfathers-bright-spark-nets-25m-deal-Dragons-Den.html> (Year: 2007).\*

\* cited by examiner

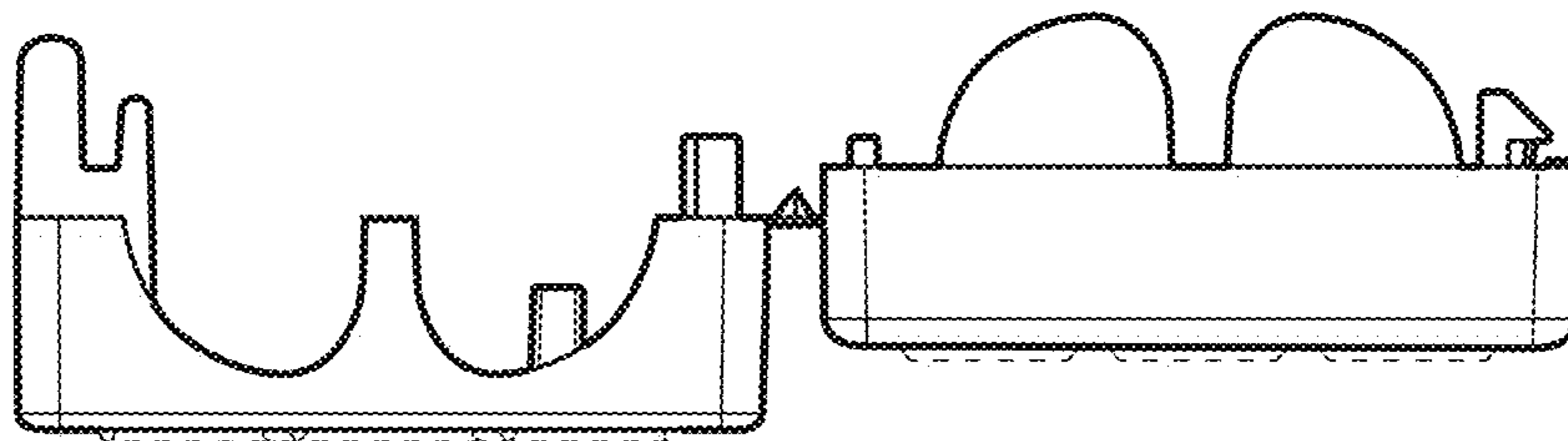


**FIG. 1**

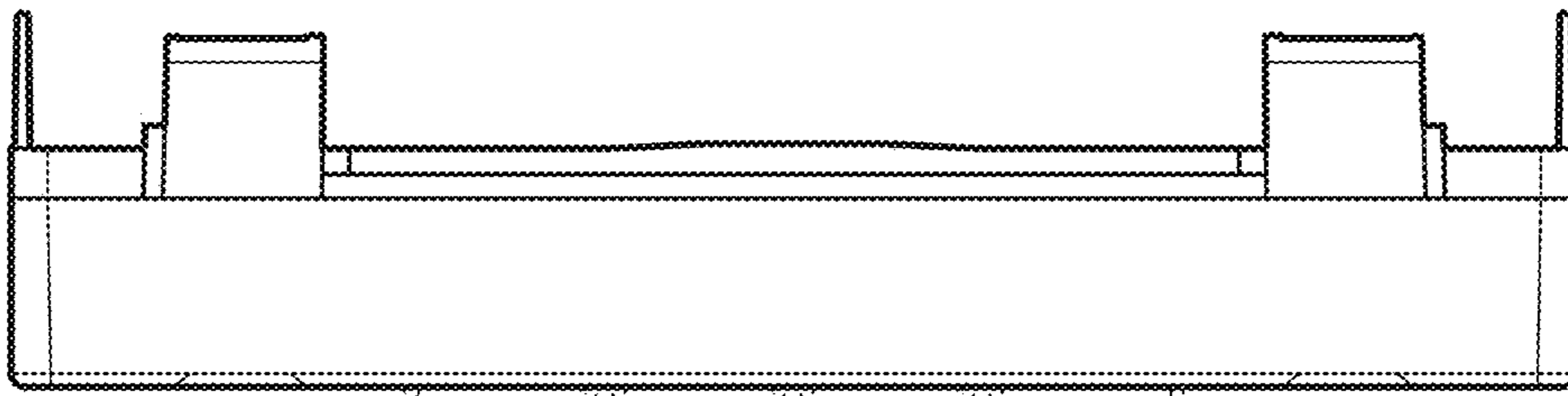




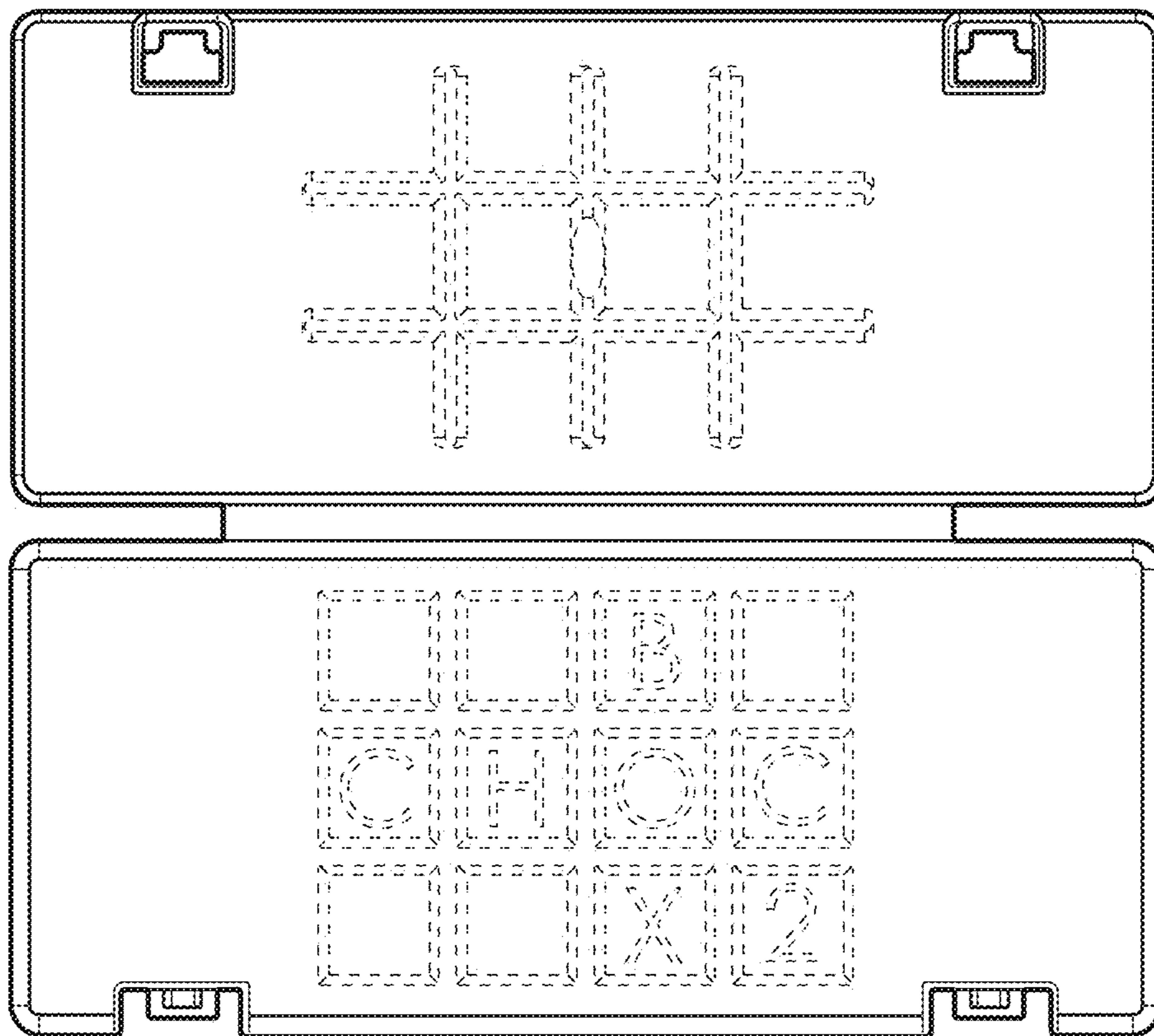
**FIG. 2**



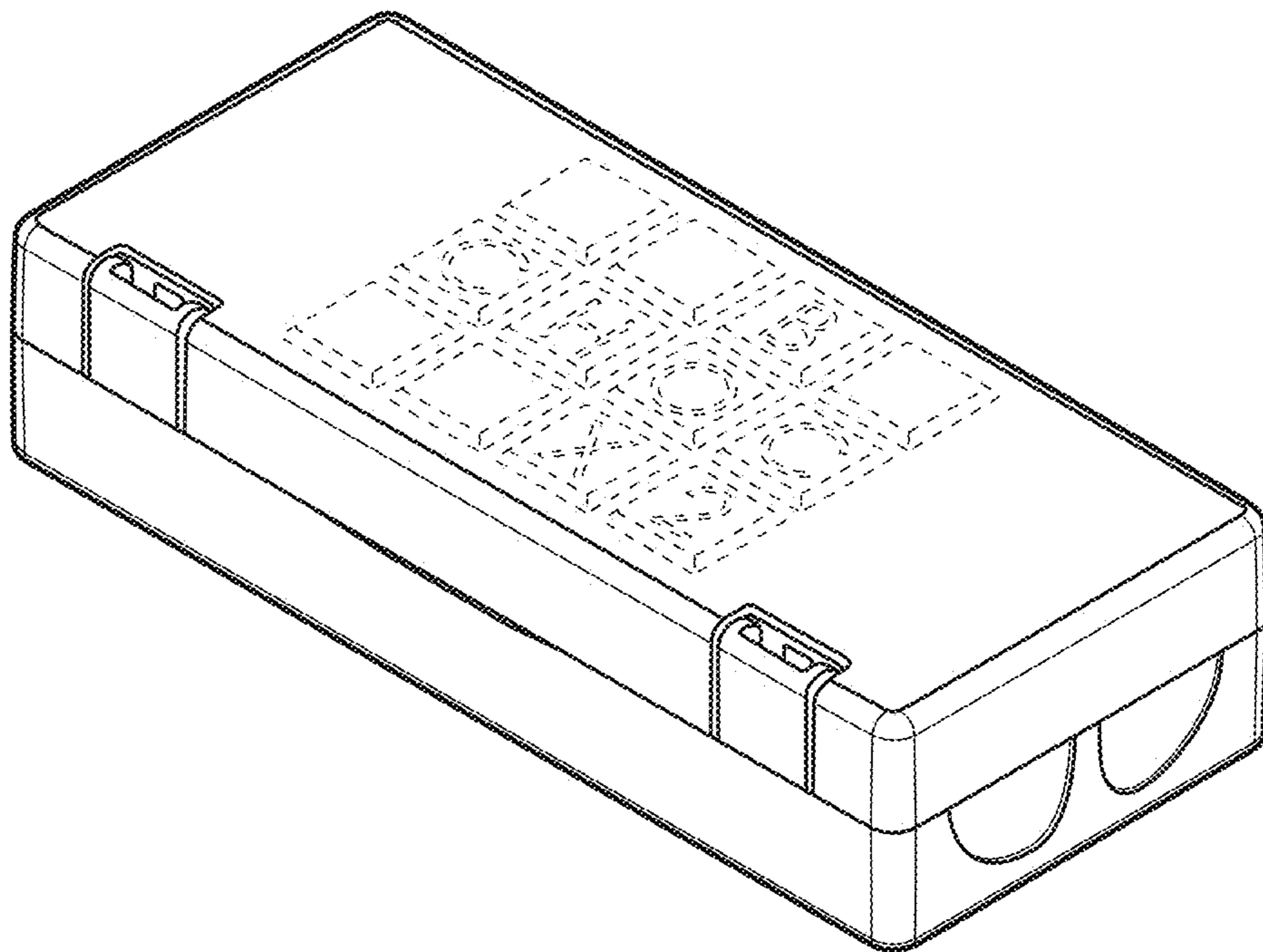
***FIG. 3***



***FIG. 4***

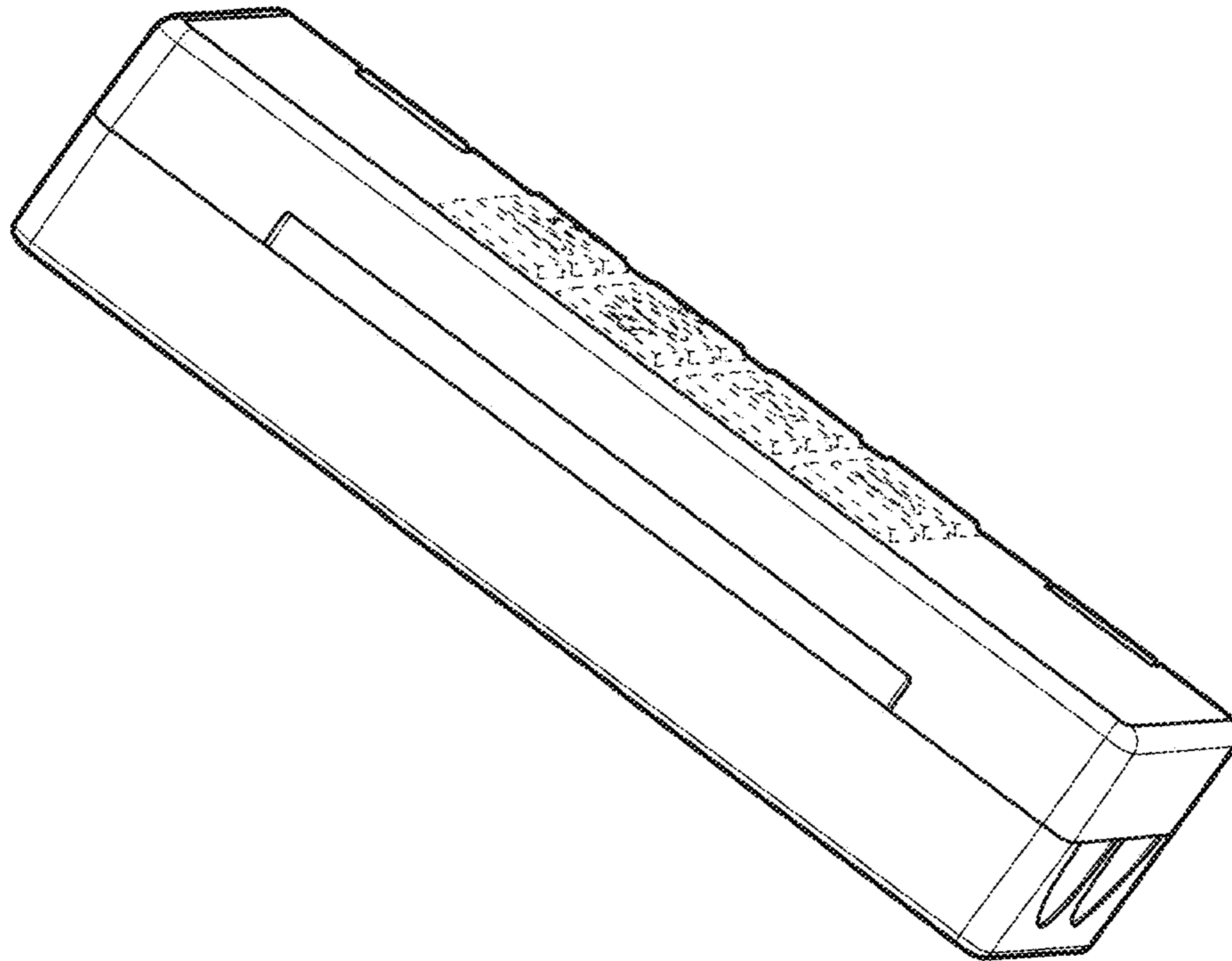


**FIG. 5**

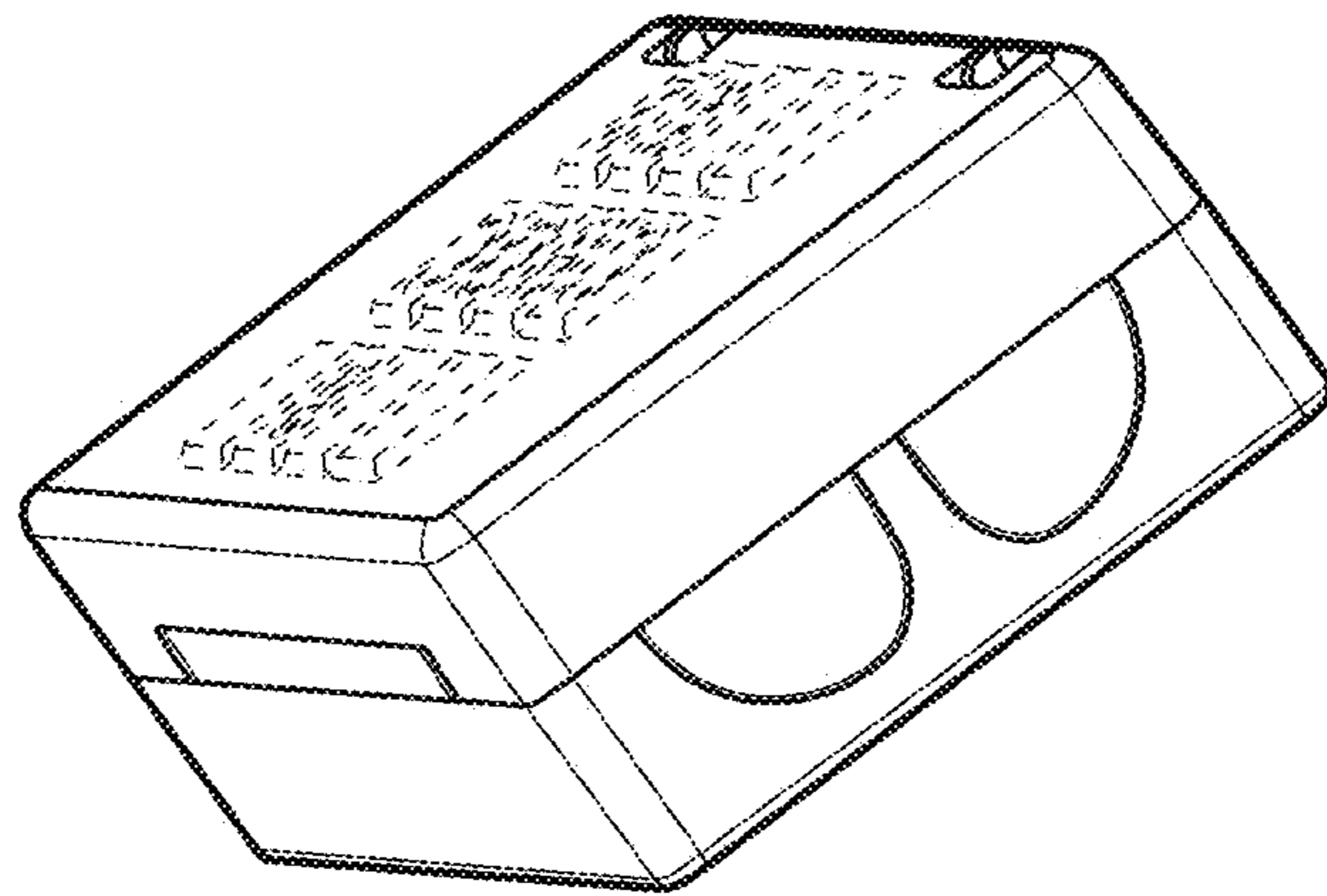


**FIG. 6**

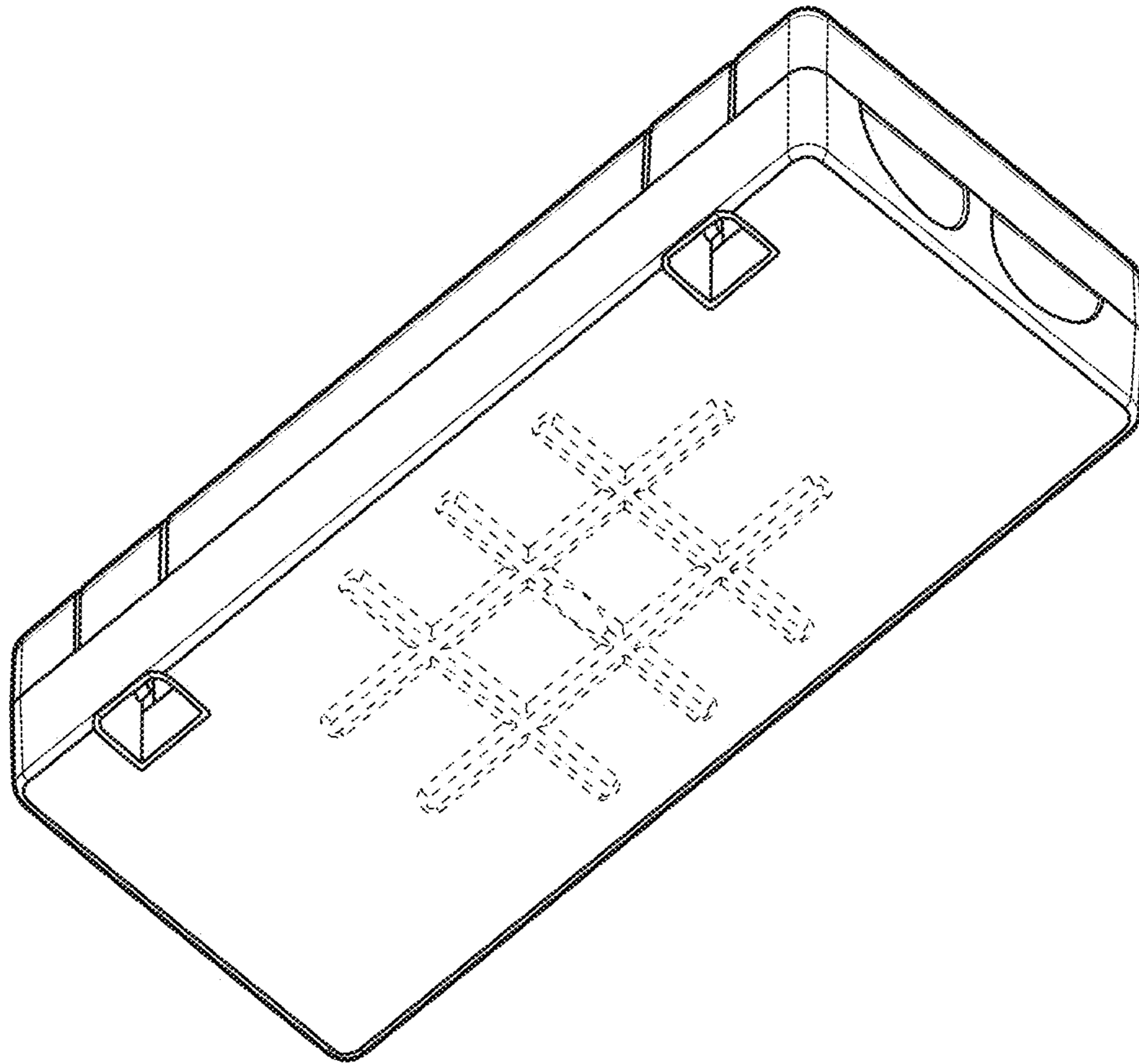




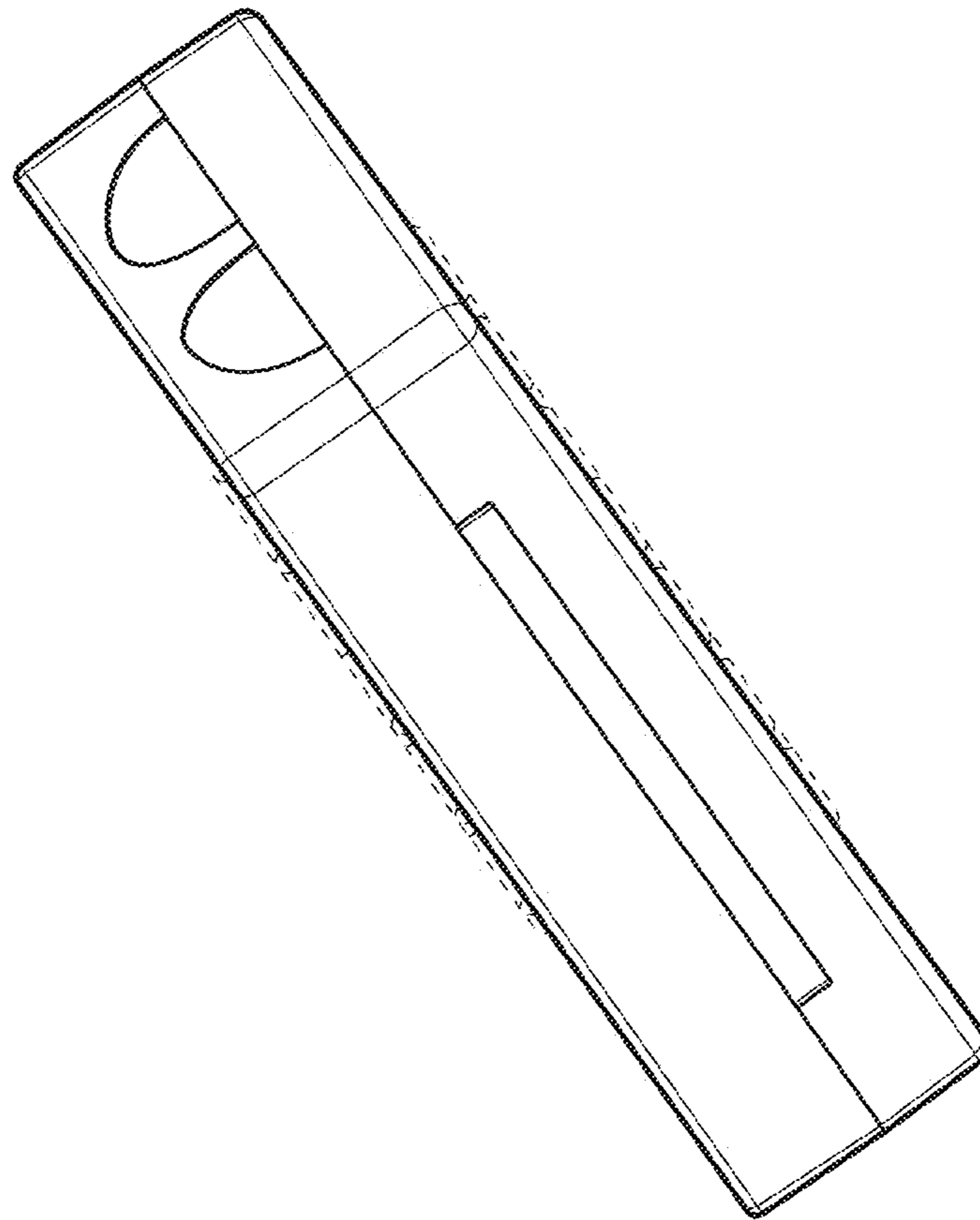
***FIG. 7***



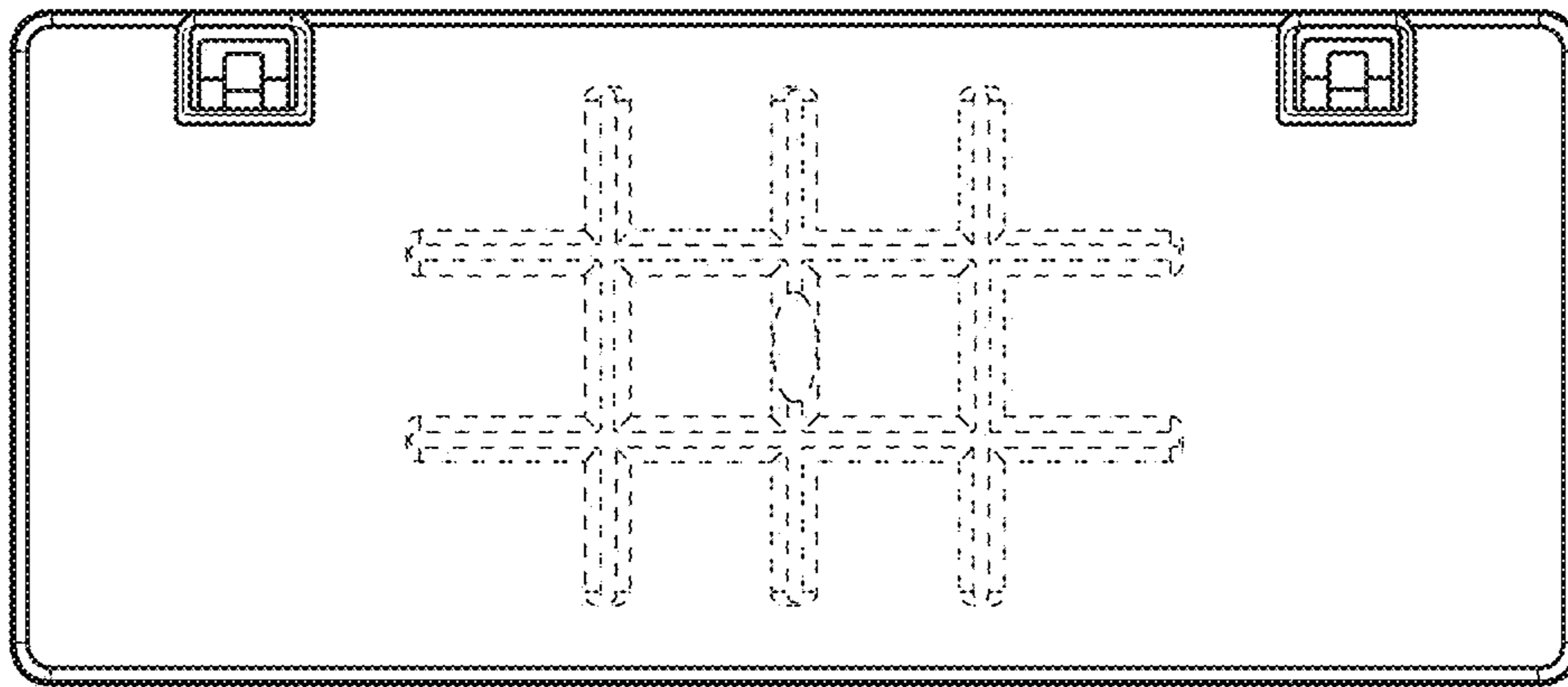
***FIG. 8***



**FIG. 9**



***FIG. 10***



***FIG. 11***