



US00D878977S

(12) **United States Design Patent** (10) **Patent No.:** **US D878,977 S**
Ewing et al. (45) **Date of Patent:** **** Mar. 24, 2020**

(54) **REAR BUMPER FOR A MODEL VEHICLE**

1,836,610 A 12/1931 McMurdo
1,867,708 A 7/1932 Paton
1,982,775 A 12/1934 Williams

(71) Applicant: **Traxxas, LP**, McKinney, TX (US)

(Continued)

(72) Inventors: **Adam Cole Ewing**, McKinney, TX (US); **Jory Sprowl**, McKinney, TN (US); **Kent Poteet**, Lucas, TX (US); **Terry Soward**, Van Alstyne, TX (US)

FOREIGN PATENT DOCUMENTS

TW D147600 S 6/2012
TW D154920 S 7/2013

(Continued)

(73) Assignee: **TRAXXAS LP**, McKinney, TX (US)

(**) Term: **15 Years**

OTHER PUBLICATIONS

(21) Appl. No.: **29/661,443**

TRAXXAS LP; The New Traxxas Summit 16.8 V Electric Extreme Terrain Monster Truck; Traxxas Press Release; Oct. 16, 2008.

(Continued)

(22) Filed: **Aug. 28, 2018**

(51) **LOC (12) Cl.** **12-16**

(52) **U.S. Cl.**

USPC **D12/171**; D12/169

(58) **Field of Classification Search**

USPC D12/86, 90, 91, 92, 163, 164, 169, 171, D12/196, 216

CPC B60R 19/02; B60R 19/18; B60R 19/24; B60R 19/56; B60R 2019/007; B62D 25/0845

See application file for complete search history.

Primary Examiner — Darlington Ly

(74) *Attorney, Agent, or Firm* — Daryl R. Wright; Greg Carr

(57) **CLAIM**

We claim the ornamental design for a rear bumper for a model vehicle, as shown and described.

DESCRIPTION

FIG. 1 is a bottom, rear, and right side perspective view of a front bumper for a model vehicle showing our new design; FIG. 2 is a rear elevation view thereof; FIG. 3 is a front elevation view thereof; FIG. 4 is a right side view thereof; FIG. 5 is a left side view thereof; FIG. 6 is a top plan view thereof; FIG. 7 is a bottom plan view thereof; and, FIG. 8 is a top, front, and right side perspective view thereof. The broken lines in the drawings illustrate portions of the rear bumper for a model vehicle that form no part of the claimed design.

1 Claim, 5 Drawing Sheets

(56) **References Cited**

U.S. PATENT DOCUMENTS

1,355,592 A	10/1920	De Graw
1,414,382 A	5/1922	Stafford
1,427,624 A	8/1922	Newton
1,448,504 A	3/1923	Plante
1,464,321 A	8/1923	Koester et al.
1,468,868 A	9/1923	Reichstetter, Jr. et al.
1,487,352 A	3/1924	Nelson
1,494,867 A	5/1924	Rahe
1,509,394 A	9/1924	Cox
1,534,760 A	4/1925	Blackmore
1,633,603 A	6/1927	Spencer
1,655,978 A	1/1928	Vella
1,729,731 A	10/1929	Vidach

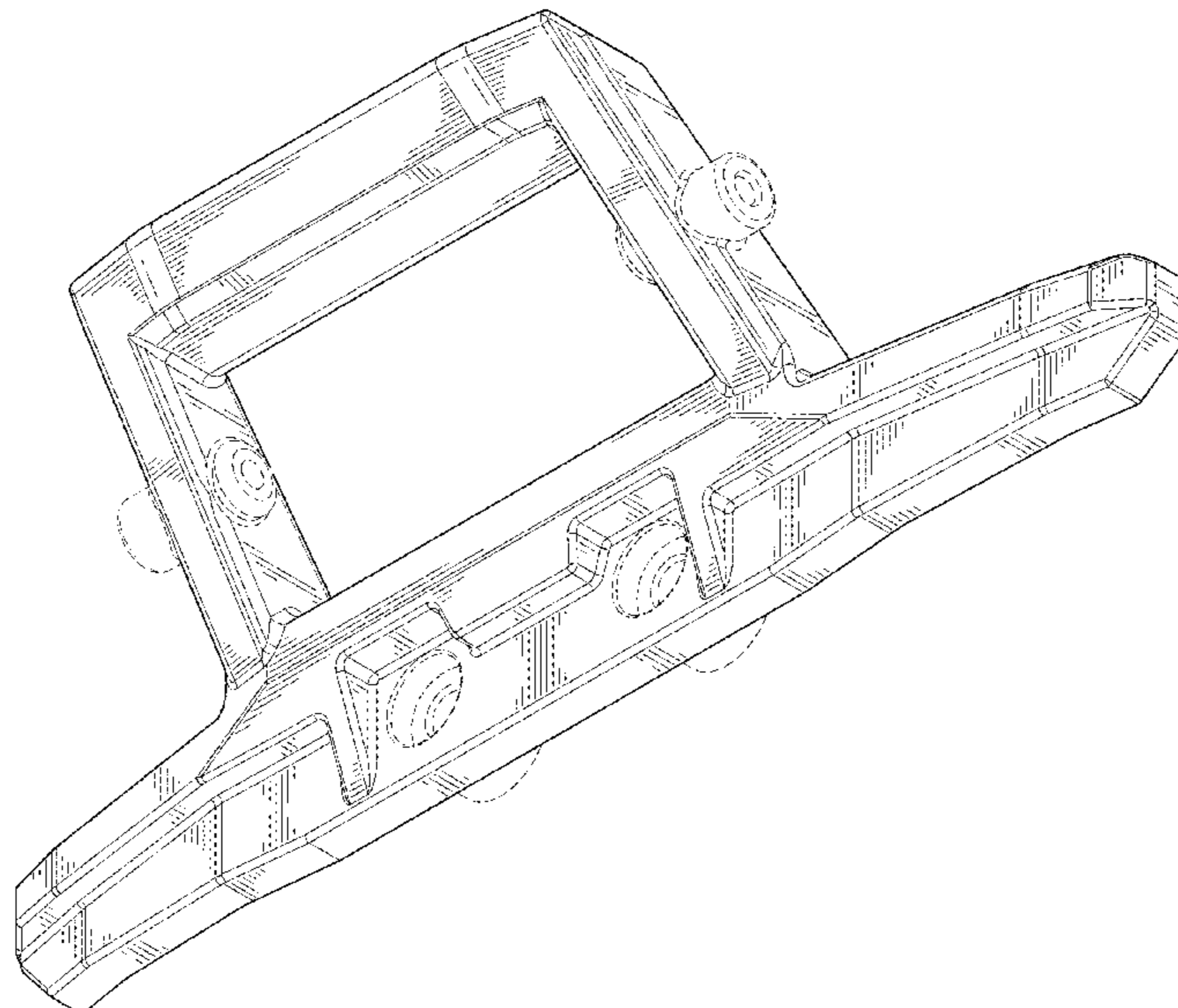

(56)

References Cited

U.S. PATENT DOCUMENTS

2,038,964 A 4/1936 Smith
 2,144,357 A 1/1939 Booharin
 2,146,642 A 2/1939 Muefh
 2,227,560 A 1/1941 Szabo
 2,236,507 A 4/1941 Kreits
 D160,661 S 12/1949 Ross
 2,502,483 A 4/1950 Sauer et al.
 2,604,349 A 7/1952 Martinetz
 3,547,469 A 12/1970 Sancioni
 3,663,048 A 5/1972 Zimmerle
 3,689,054 A 9/1972 Gouirand
 3,756,643 A 9/1973 Weed
 3,774,948 A 11/1973 Gouirand
 3,782,767 A 1/1974 Moore
 3,829,118 A 8/1974 Gouirand
 3,837,695 A 9/1974 Haase et al.
 3,938,840 A 2/1976 Haase et al.
 3,971,583 A 7/1976 Kornhauser
 4,264,094 A 4/1981 White et al.
 D275,776 S 10/1984 Horowitz et al.
 D300,128 S 3/1989 Brennan
 5,181,699 A 1/1993 Chang
 5,326,083 A 7/1994 Wydra et al.
 D360,865 S 8/1995 Hanson
 D375,067 S 10/1996 Bronstein
 D403,023 S 12/1998 Araki
 5,971,451 A 10/1999 Huang
 D420,634 S 2/2000 Nelson
 D420,962 S 2/2000 Chevalier
 D422,953 S 4/2000 Waagenaar
 D425,462 S 5/2000 Ujiie
 D431,506 S 10/2000 Runfola
 D432,469 S 10/2000 Nelson
 6,217,090 B1 4/2001 Berzinji
 D454,098 S 3/2002 McGuinness
 D454,099 S 3/2002 McGuinness
 D454,817 S 3/2002 McGuinness
 D455,684 S 4/2002 McGuinness
 D455,988 S 4/2002 McGuinness
 D462,401 S 9/2002 Wu
 D462,727 S 9/2002 Wu
 D464,087 S 10/2002 Wu
 D476,606 S 7/2003 Hamm et al.
 D485,219 S 1/2004 Hamm et al.
 D487,038 S 2/2004 Chan
 D502,433 S 3/2005 McClanahan
 D506,421 S 6/2005 Newbill
 D521,572 S 5/2006 Yuen
 7,097,222 B2 8/2006 Ran
 D527,696 S 9/2006 Ichikawa et al.
 D532,348 S 11/2006 Kudo et al.
 D533,606 S 12/2006 Kaminski
 D534,593 S 1/2007 Yuen
 D577,083 S 9/2008 Nakayama
 D580,322 S 11/2008 Schroeder et al.
 D590,752 S 4/2009 Williams et al.
 D593,616 S 6/2009 Asai
 D606,913 S 12/2009 Robertson
 7,703,834 B1 * 4/2010 Hardy B60R 9/06
 296/102
 D636,305 S 4/2011 Alvarez et al.
 D642,099 S 7/2011 Nagao et al.
 D683,281 S 5/2013 Harriton
 D691,074 S 10/2013 Dugardin
 D697,842 S 1/2014 Harriton
 D699,640 S 2/2014 Duderstadt
 D704,107 S 5/2014 Peltola et al.
 D713,305 S 9/2014 Sperling et al.
 D716,201 S 10/2014 Ewing et al.
 D722,927 S 2/2015 Schroeder et al.
 D726,605 S 4/2015 Schroeder
 D728,038 S 4/2015 Ewing et al.
 D737,181 S 8/2015 Smith et al.
 D737,724 S 9/2015 Schroeder et al.
 D737,739 S 9/2015 Hanson et al.

D740,730 S 10/2015 Peltola et al.
 D741,233 S 10/2015 Glover et al.
 D744,384 S 12/2015 Harriton
 D744,386 S 12/2015 Harriton
 D744,387 S 12/2015 Harriton
 D749,021 S 2/2016 Boniface et al.
 D749,995 S 2/2016 Azadi et al.
 D751,012 S * 3/2016 Hare D12/169
 D753,034 S 4/2016 Thole et al.
 D760,133 S 6/2016 Bennett et al.
 D761,166 S 7/2016 Hare
 D763,745 S 8/2016 Lee, IV et al.
 D771,537 S 11/2016 Hare
 D775,013 S 12/2016 Bennett et al.
 D775,016 S 12/2016 Reynolds
 D776,582 S 1/2017 Bennett et al.
 D777,618 S 1/2017 Setina
 D777,619 S * 1/2017 Barajas D12/167
 D778,213 S 2/2017 Platto et al.
 D778,784 S 2/2017 Hirooka
 D781,193 S 3/2017 McMath
 D781,757 S 3/2017 Baggett
 D784,869 S 4/2017 Yamamoto
 D785,504 S 5/2017 Higgs
 D786,745 S 5/2017 Zeng
 D792,817 S * 7/2017 McMath D12/169
 D792,818 S 7/2017 McMath
 D793,304 S 8/2017 McMath
 D794,519 S 8/2017 McMath
 D796,399 S 9/2017 Steen
 D800,036 S 10/2017 Bennett et al.
 D800,226 S 10/2017 Zeng
 D801,892 S 11/2017 Drever
 D811,956 S * 3/2018 Zeng D12/169
 D821,275 S * 6/2018 Eck D12/171
 D823,750 S 7/2018 Schulzetenberg et al.
 D826,115 S 8/2018 Chi
 D827,054 S 8/2018 Ewing et al.
 D827,055 S 8/2018 Barajas et al.
 D830,919 S * 10/2018 Zeng D12/167
 D832,161 S * 10/2018 Kobayashi D12/171
 D832,368 S 10/2018 Barajas et al.
 D833,922 S 11/2018 DiCanzio
 D845,847 S * 4/2019 Piscitelli D12/169
 D846,460 S * 4/2019 Goodrich D12/169
 D846,462 S * 4/2019 DiCanzio D12/171
 D847,051 S 4/2019 DiCanzio
 D864,806 S * 10/2019 Wood D12/171
 2009/0212581 A1 8/2009 Drever
 2009/0302623 A1 12/2009 Finney
 2013/0187395 A1 7/2013 Hanson et al.
 2017/0088076 A1 * 3/2017 Fujimoto B60R 19/44
 2017/0247014 A1 8/2017 Farooq et al.
 2017/0349227 A1 12/2017 Spindler et al.

FOREIGN PATENT DOCUMENTS

TW D163365 S 10/2014
 TW D168397 S 6/2015
 TW D169825 S 8/2015

OTHER PUBLICATIONS

Summit E-Revo Crawler SP08503 front bumper; Oct. 16, 2008.
 "How Do I Add a Ball Hitch to my RPM Rear Bumper (T/E-Maxx & Revo Bumpers)?" RPM, Jul. 30, 2005 [online], [retrieved on Sep. 12, 1996]. Retrieved from the internet, URL: <http://www.rpmproducts.com/faq/add-ball-hitch-rpm-rear-bumper-te-maxx-revo-bumpers/>.
 "WARN 87750 Elite Series Front Bumper with Grill Guard Tube" RPM, Jul. 17, 2013 [online], [retrieved on Sep. 12, 2016]. Retrieved from Internet, URL: https://www.amazon.com/gp/product/B00625F4FI/ref=pd_sim_263_5?ie=UTF8&pd_rd_i=B00625F4FI&pd_rd_r=QN6NZ5WV34ZS00Z3BSGH&pd_rd_w=4XjJD&pd_rd_wg=7Z80V&psc=1&refRID=QN6NZ5WV34ZS0.
 "Yeah Racing F/R Bumper w/ HD Shackle & LED's—SCX10, Traxxas." RC Hobbies, Nov. 12, 2014 [online], [retrieved on Sep.

(56)

References Cited

OTHER PUBLICATIONS

12, 2016]. Retrieved from the Internet <URL: http://rchobbies.com.au/store/product_info.php?products_id=80405>.

Taiwan IPO Search Report; Taiwan Design Patent App No. 105301434; dated Aug. 4, 2016.

Associated Electrics; “Catalog and Parts Listing for the Monster GT Truck”; 2003; Associated Electrics, Inc., Costa Mesa, California.

Horizon Hobby; “Team Losi LST Super Truck—Drive Train Assy” exploded view; Horizon Hobby, Inc., Champaign, Illinois.

HPI Racing, “Savage 21 4WD Giant Monster Truck” p. 56 exploded view; Hobby Products International, Foothill Ranch, California.

Tamiya, “Terra Crusher Parts Breakdown—Front End”; Tamiya America, Inc., Aliso Viejo, California.

Tamiya, “Wild Willy 2 Parts Breakdown”; 1999, Tamiya America, Inc., Aliso Viejo, California.

Tamiya, “Wild Willy”; Tamiya America, Inc., Aliso Viejo, California; 1 photograph.

TRAXXAS, “T-MAXX Assemblies—Front Assembly”; TRAXXAS LP, Plano, Texas.

Axial SCX10 II 2000 Jeep Cherokee; <http://www.axialracing.com/products/ax90047>; Aug. 2016.

Axial SCX 10 Deadbolt; <http://www.axialracing.com/products/ax90044>; Aug. 2016.

Traxxas; Bumper support geometry, body mounts, body mount posts; <https://traxxas.com/products/parts/3619>; Oct. 2016.

Sema 2015 Fab Fours; 2 photos.

* cited by examiner

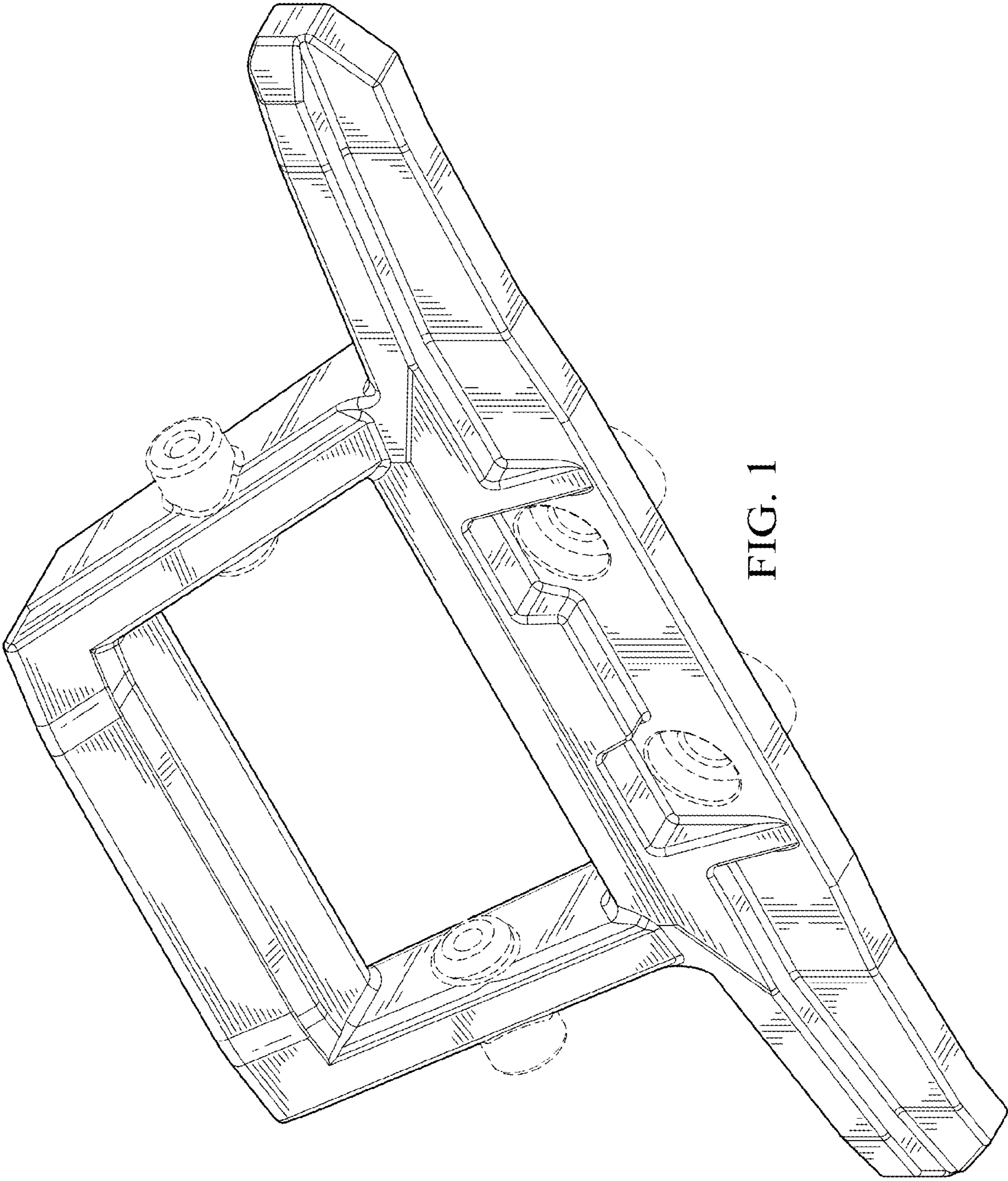
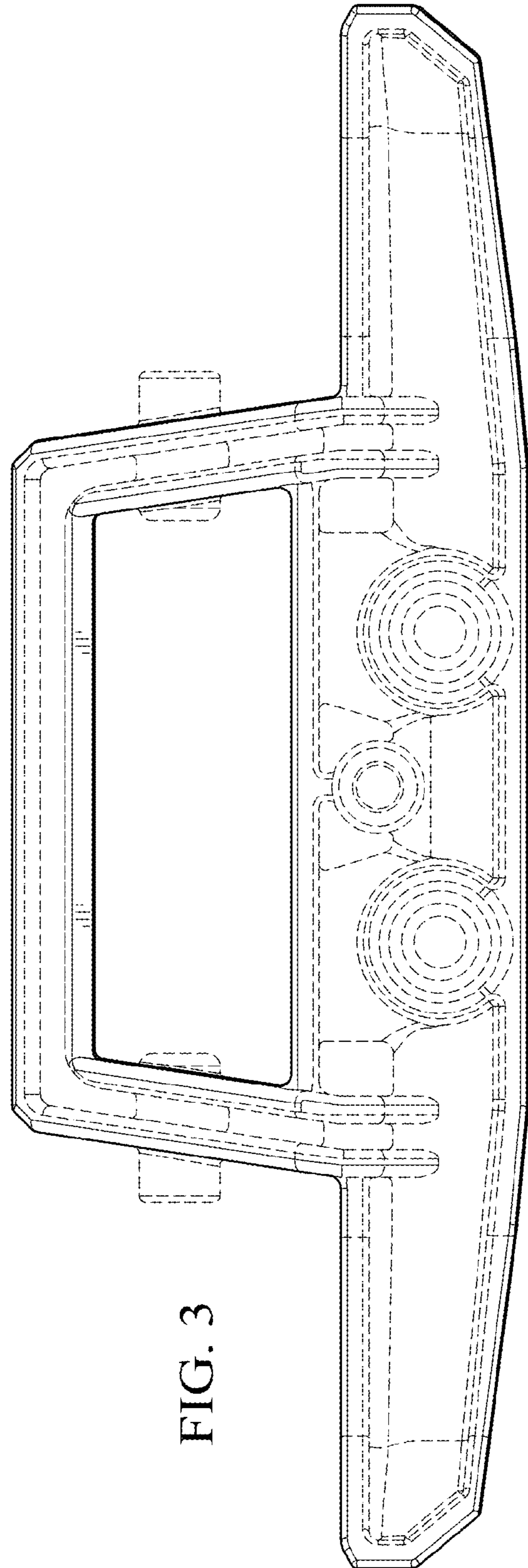
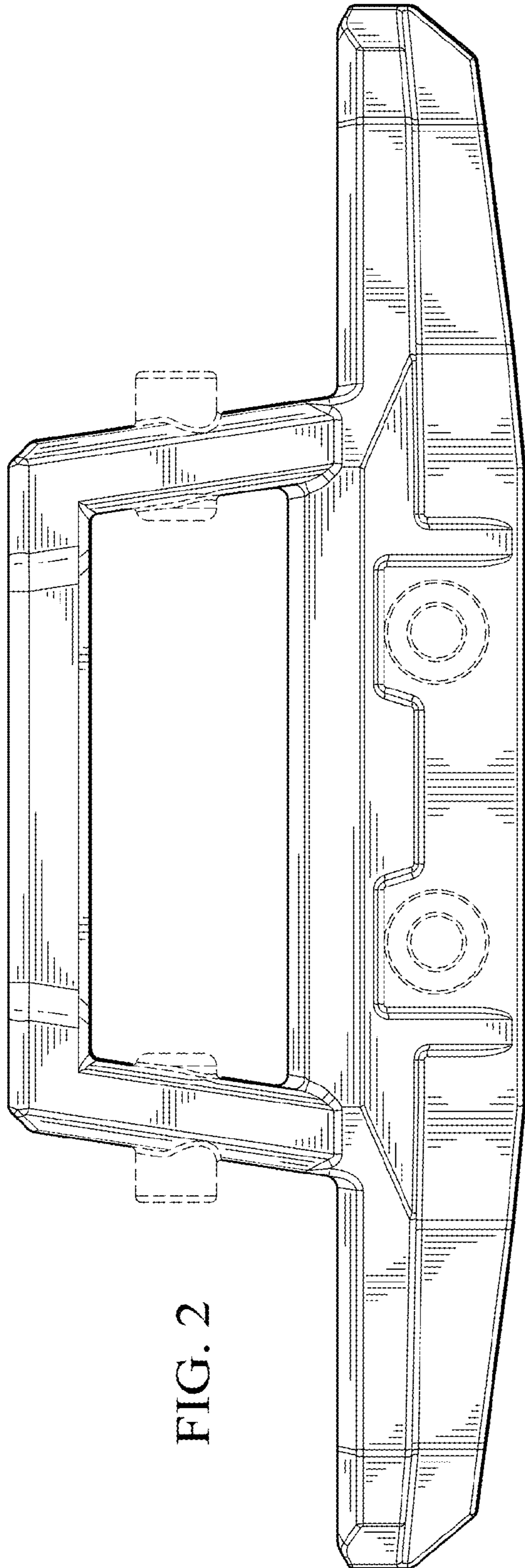

FIG. 1



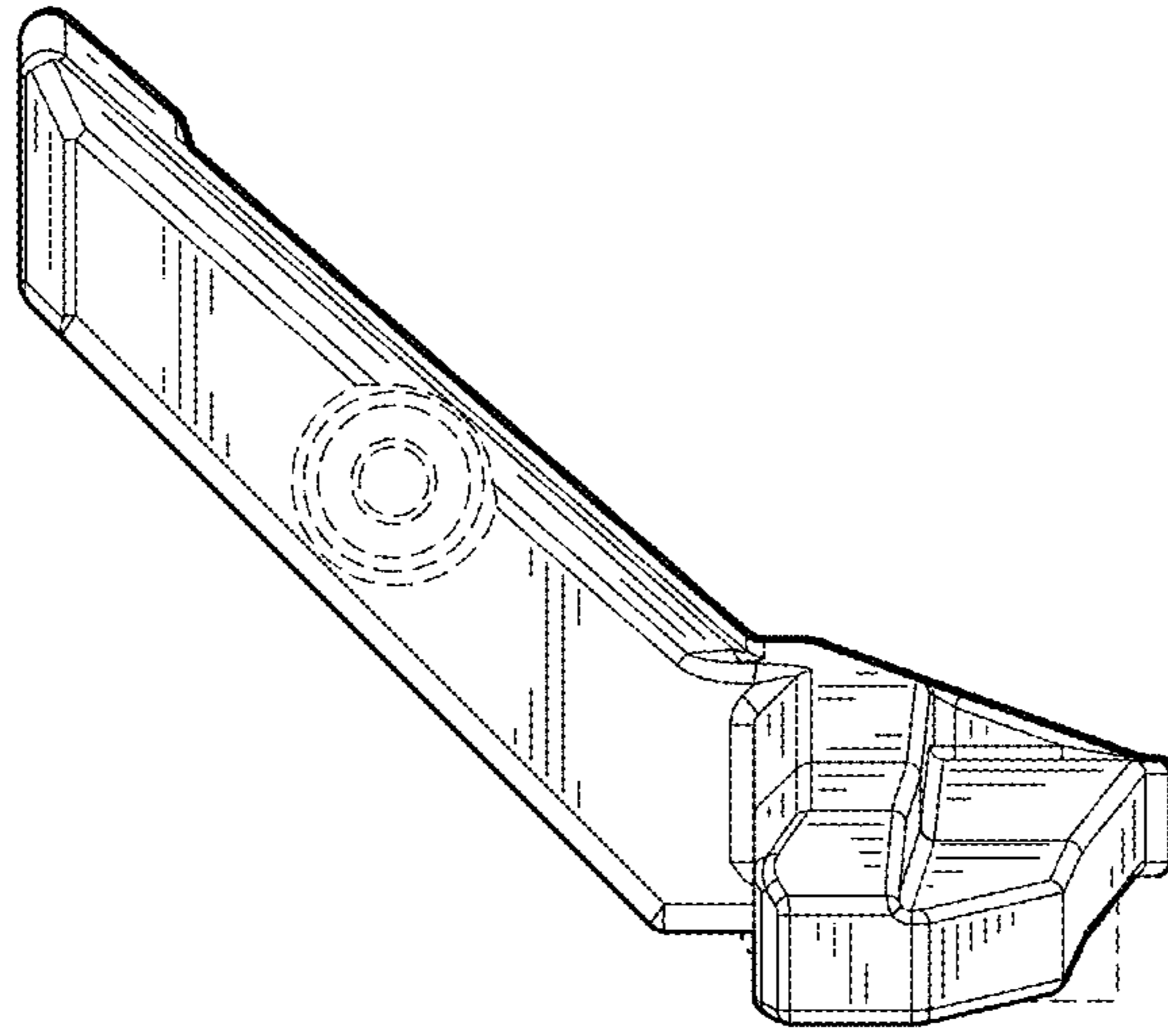

FIG. 5

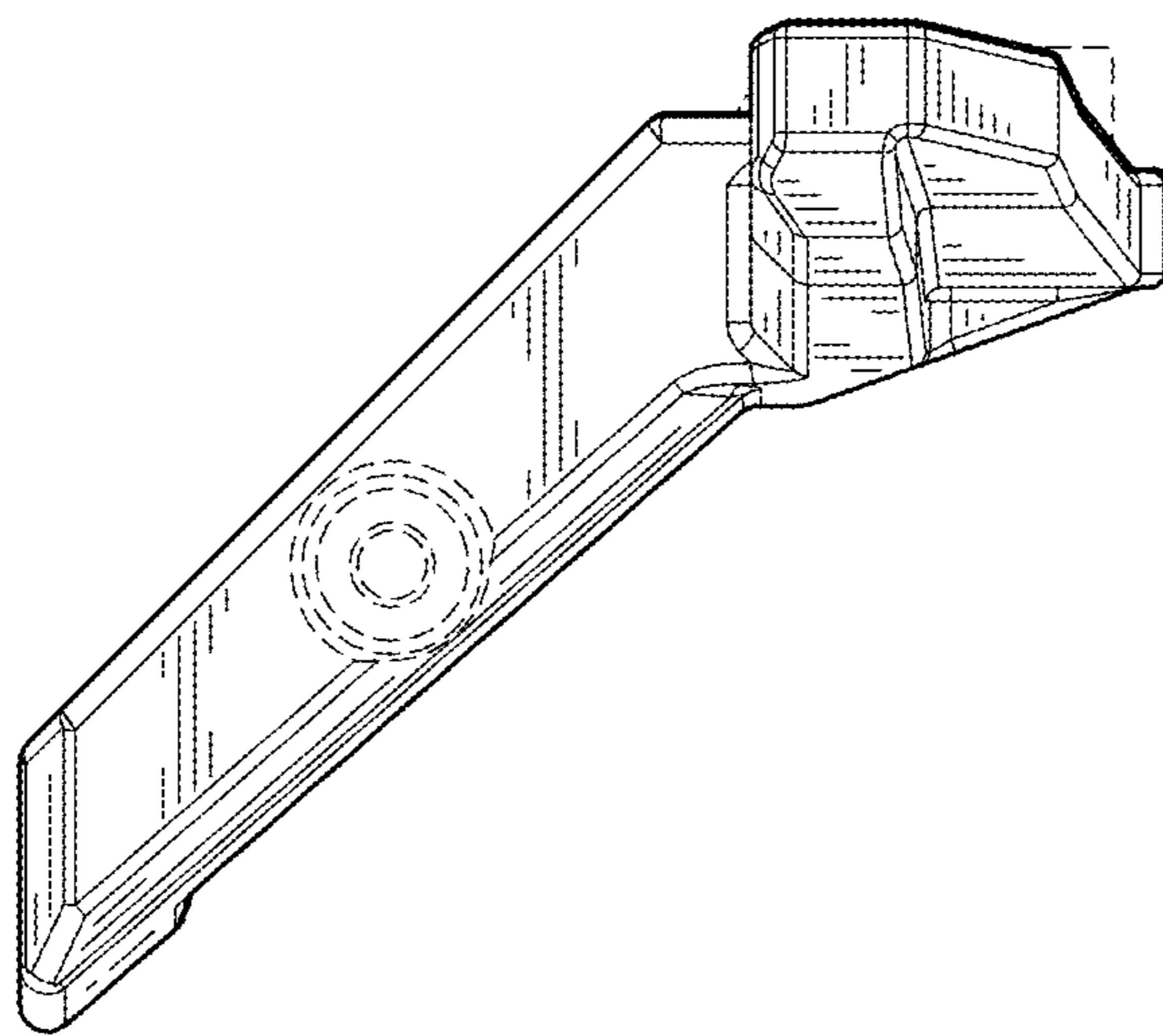

FIG. 4

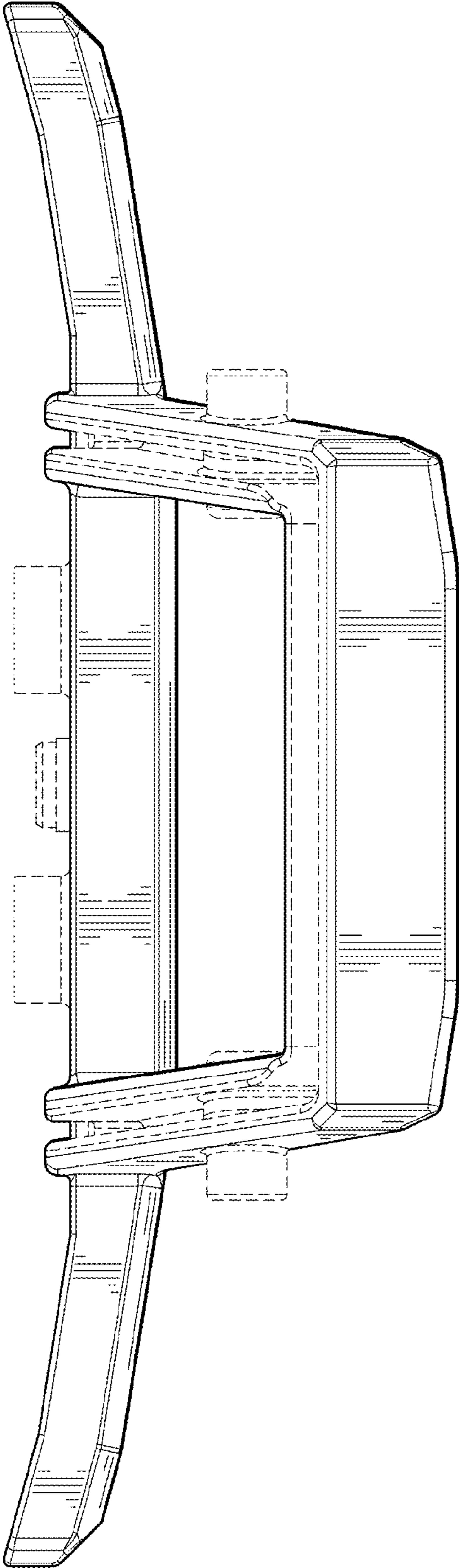

FIG. 6

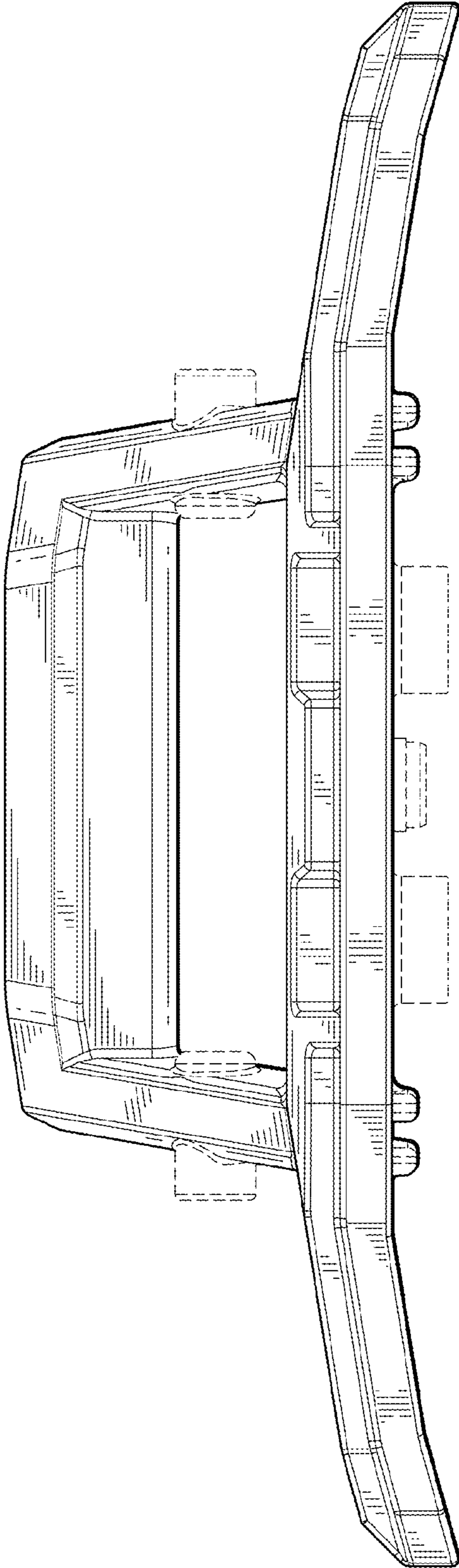

FIG. 7

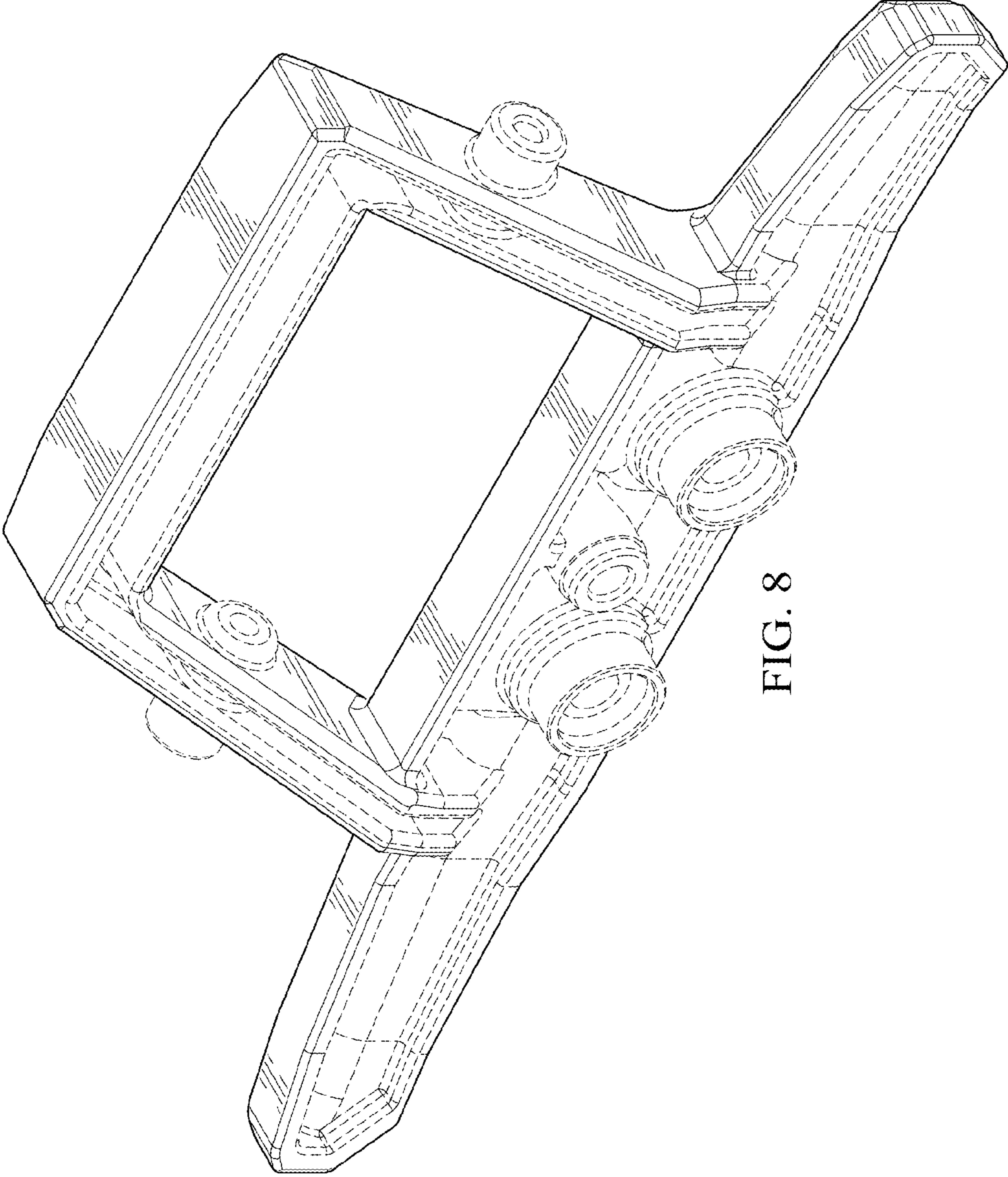

FIG. 8