



US00D878862S

(12) **United States Design Patent** (10) **Patent No.:** **US D878,862 S**
Kettavong et al. (45) **Date of Patent:** **** Mar. 24, 2020**

(54) **BLENDING SYSTEM** 13/0064; B02C 1/08; B02C 2/04; B02C 4/42; B02C 4/142; B02C 4/143; B02C 4/423; B02C 13/1835; B28C 5/10; B28C 5/12; B28C 5/14; B28C 5/16
 (71) Applicant: **Vita-Mix Management Corporation**, Olmsted Township, OH (US)
 (72) Inventors: **Phonesacksith Guy Kettavong**, Kent, OH (US); **Jack Warren Gee, II**, Willoughby, OH (US); **Kolman Juhasz**, Parma, OH (US); **Eugene J. Kozlowski**, Medina, OH (US); **David A. Kanning**, Valley City, OH (US); **Michael Patrick Arnett**, Columbia Station, OH (US); **Richard Joseph Lash**, Avon Lake, OH (US)
 See application file for complete search history.

(56) **References Cited**

U.S. PATENT DOCUMENTS

2,282,866	A	5/1942	Hagen
3,548,280	A	12/1970	Cockroft
3,627,008	A	12/1971	Samuelian
4,335,860	A	6/1982	Grandel et al.
4,471,915	A	9/1984	Levin et al.
4,678,881	A	7/1987	Griffith
4,741,482	A	5/1988	Coggiola et al.
4,885,917	A	12/1989	Spector
4,913,555	A	4/1990	Maeda et al.
4,993,840	A	2/1991	Maeda et al.
5,225,078	A	7/1993	Polasky et al.
5,273,358	A	12/1993	Byrne et al.
5,274,207	A	12/1993	Griffith
5,368,384	A	11/1994	Duncan et al.
5,478,149	A	12/1995	Quigg
5,567,049	A	10/1996	Beaudet et al.
5,852,968	A	12/1998	Sundquist
5,855,431	A	1/1999	Costanzo
6,095,677	A	8/2000	Karkos, Jr. et al.
6,149,035	A	11/2000	Gorski et al.
6,210,033	B1	4/2001	Karkos, Jr. et al.
6,318,247	B1	11/2001	Di Nunzio et al.
6,325,312	B1	12/2001	Karkos, Jr.
6,336,603	B1	1/2002	Karkos, Jr. et al.
6,416,215	B1	7/2002	Terentiev
6,460,368	B1	10/2002	Grande Damaso
6,494,390	B1	12/2002	Khait et al.
6,513,966	B1	2/2003	Gort-Barten et al.
6,540,394	B2	4/2003	Juriga
6,554,466	B1	4/2003	Lee
6,568,843	B1	5/2003	Lai
6,629,492	B1	10/2003	Li
6,637,681	B1	10/2003	Planca et al.
6,712,497	B2	3/2004	Jersey et al.
6,758,593	B1	7/2004	Terentiev
6,793,167	B2	9/2004	Karkos, Jr. et al.
6,899,454	B2	5/2005	Terentiev
6,910,800	B2	6/2005	Wu
D512,265	S	12/2005	McCurrach
D518,994	S	4/2006	Lin
D526,531	S	8/2006	Drees
D528,363	S	9/2006	Ulanski et al.

(73) Assignee: **Vita-Mix Management Corporation**, Olmsted Township, OH (US)
 (**) Term: **15 Years**
 (21) Appl. No.: **29/682,508**
 (22) Filed: **Mar. 6, 2019**

Related U.S. Application Data

(62) Division of application No. 29/630,478, filed on Dec. 21, 2017, now Pat. No. Des. 842,644, which is a division of application No. 29/584,798, filed on Nov. 17, 2016, now Pat. No. Des. 807,118, which is a division of application No. 29/485,013, filed on Mar. 14, 2014, now Pat. No. Des. 771,999.

(51) **LOC (12) Cl.** **31-00**

(52) **U.S. Cl.**
 USPC **D7/412; D7/376; D7/378; D7/386**

(58) **Field of Classification Search**
 USPC D7/372, 376-386, 392.1, 412-413, 602, D7/629, 665-666, 669, 679, 693-694
 CPC .. A21C 1/02; A21C 1/04; A23G 9/045; A23N 1/00; A23N 1/02; A47J 19/027; A47J 36/10; A47J 43/04; A47J 43/25; A47J 43/27; A47J 43/042; A47J 43/044; A47J 43/046; A47J 43/075; A47J 43/0722; A47J 43/0727; B01F 3/00; B01F 3/0807; B01F 3/0853; B01F 13/0059; B01F

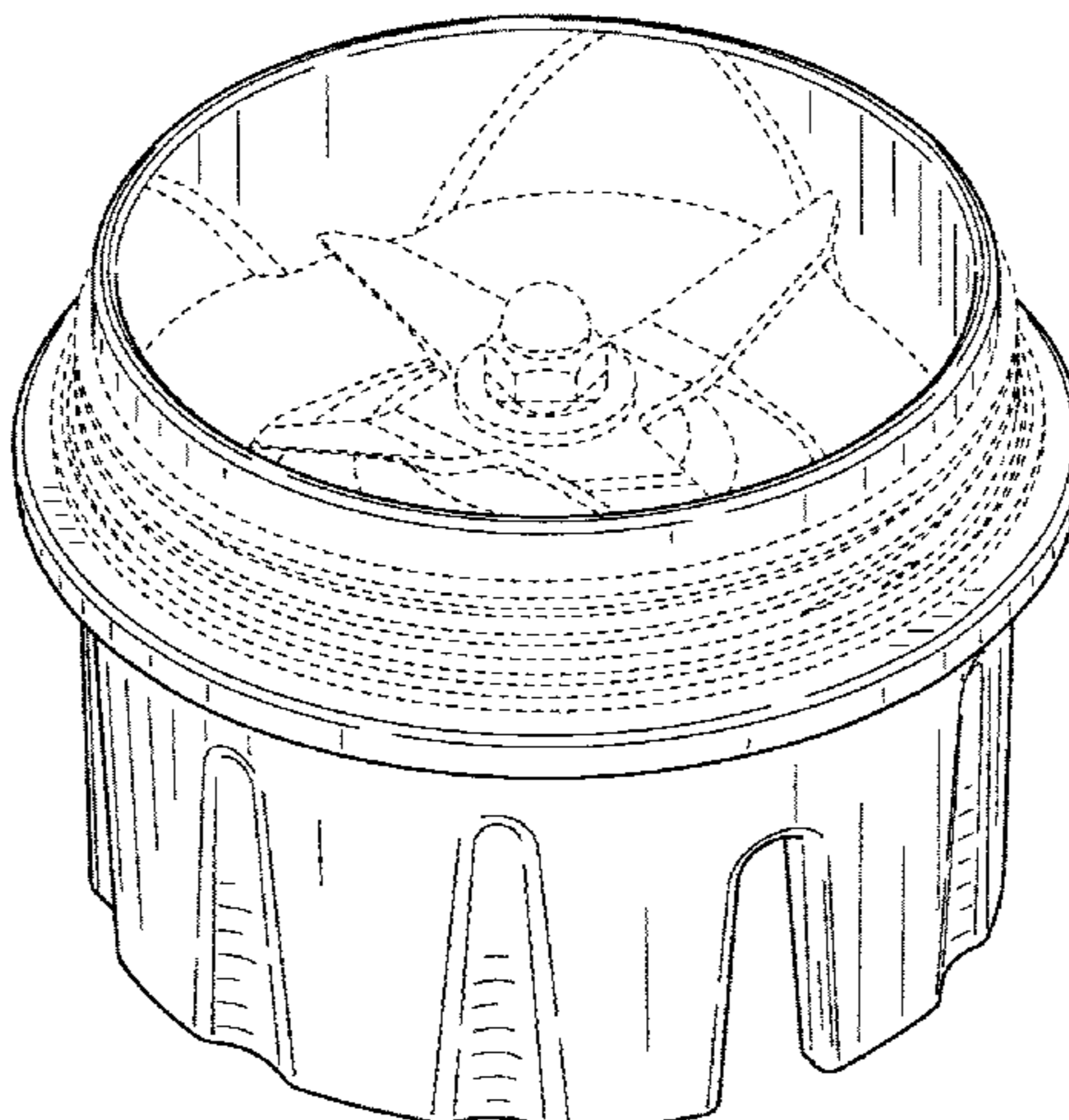

US D878,862 S

D549,043	S	8/2007	Beesley	
7,270,156	B2	9/2007	Beeslet et al.	
7,314,307	B2	1/2008	Cai	
7,318,666	B1	1/2008	Lin	
D568,096	S	5/2008	Sun	
7,407,320	B1	8/2008	Lin	
D577,537	S	9/2008	Lee	
D588,406	S *	3/2009	Ulanski	A47J 36/10 D7/413
7,530,510	B2	5/2009	Newman et al.	
D603,215	S	11/2009	Hollinger	
D605,462	S	12/2009	Picozza	
D617,136	S	6/2010	Bock	
D621,656	S	8/2010	Ulanski et al.	
7,871,196	B2	1/2011	Lin	
7,905,728	B2	3/2011	Piontek	
8,087,818	B2	1/2012	Drees	
8,186,872	B2	5/2012	Bartholomew et al.	
D662,359	S	6/2012	Boozer et al.	
8,220,730	B2	7/2012	Ferraby et al.	
8,230,774	B1	7/2012	Hunte	
8,240,909	B2	8/2012	Athey et al.	
8,282,268	B2	10/2012	Karkos, Jr. et al.	
8,360,480	B2	1/2013	Athey et al.	
8,376,253	B2	2/2013	Oblak et al.	
8,403,555	B2	3/2013	Wu	
8,403,556	B2	3/2013	Wu	
8,480,292	B2	7/2013	Dushine et al.	
8,550,388	B2	10/2013	Donaldson et al.	
D694,573	S	12/2013	Norland	
D694,574	S	12/2013	Norland	
D694,582	S	12/2013	Norland	
D694,583	S	12/2013	Norland	
8,621,990	B2	1/2014	Fang et al.	
8,702,300	B2	4/2014	Audette	
D711,688	S	8/2014	Prats	
8,814,072	B2	8/2014	Gushwa	
D730,683	S	6/2015	Tu	
D733,488	S	7/2015	Tu et al.	
D737,629	S	9/2015	Sands	
D765,462	S	9/2016	Davies	
D767,938	S *	10/2016	Picozza	A23G 9/045 D7/376
D771,999	S	11/2016	Kettavong et al.	
D773,248	S	12/2016	Barquin et al.	
D773,882	S	12/2016	Halton	
D779,872	S *	2/2017	Bergstrom	A47J 19/027 D7/392.1
D780,507	S	3/2017	Barquin et al.	
D783,353	S *	4/2017	Smith	D7/376
D783,355	S	4/2017	Tu	
D788,520	S	6/2017	Blaise	
D789,735	S	6/2017	Palermo et al.	
D795,005	S	8/2017	Coakley et al.	
D797,496	S	9/2017	Gee et al.	
D798,109	S	9/2017	Ulanski et al.	
D804,248	S	12/2017	Tu	
D807,118	S	1/2018	Kettavong et al.	
9,855,535	B2	1/2018	Arnett et al.	
D813,603	S *	3/2018	Tu	D7/413
D839,042	S *	1/2019	Krivos	D7/378
D839,670	S *	2/2019	Youngmann	D7/413
D844,374	S *	4/2019	McConnell	D7/386
D846,337	S *	4/2019	Duan	D7/378
D850,845	S *	6/2019	Pan	D7/378
2002/0071340	A1	6/2002	Juriga	
2005/0047272	A1 *	3/2005	Sands	A47J 19/027 366/199
2005/0174882	A1	8/2005	Krasne et al.	
2005/0258197	A1 *	11/2005	Rukavina	A23G 9/045 222/465.1
2006/0176765	A1	8/2006	Pryor, Jr. et al.	
2006/0261066	A1 *	11/2006	Boozer	A47J 36/10 220/254.7
2006/0286255	A1	12/2006	Ku et al.	
2008/0037360	A1	2/2008	McGill	
2008/0089170	A1	4/2008	Larsen et al.	
2008/0089171	A1	4/2008	Larsen	

2008/0098905	A1	5/2008	Steiner et al.
2008/0198688	A1	8/2008	Peng
2008/0264927	A1	10/2008	Peng
2009/0084274	A1	4/2009	Kovacic et al.
2009/0186139	A1	7/2009	Dragan
2009/0260523	A1	10/2009	Peng
2010/0018982	A1	1/2010	Liu
2010/0044303	A1	2/2010	Perrault et al.
2010/0046323	A1	2/2010	Tien et al.
2011/0186172	A1	8/2011	Herbert
2011/0232506	A1	9/2011	Cai
2011/0241503	A1	10/2011	Simon
2012/0206995	A1	8/2012	Wu
2012/0294109	A1	11/2012	Boozer
2013/0028044	A1	1/2013	Karkos, Jr. et al.
2013/0043337	A1	2/2013	Rukavina et al.
2013/0319034	A1	12/2013	Kounlavong et al.
2013/0344204	A1	12/2013	Goodson
2014/0212566	A1	7/2014	Herbert et al.
2014/0247686	A1	9/2014	Arnett et al.

FOREIGN PATENT DOCUMENTS

CN	101904700	12/2010
EP	0041082	5/1980
EP	1647217	4/2006
EP	1688046	8/2006
JP	1152984	8/2001
JP	1194564	3/2003
JP	1265915	7/2005
JP	1305797	6/2006
JP	1372467	11/2008
JP	1372920	11/2008
JP	1372466	12/2008
JP	1373902	4/2009
JP	1494697	9/2013
WO	2011/113083	9/2011
WO	2014/008926	1/2014
WO	2014/009339	1/2014
WO	2014/121838	8/2014
WO	2014/122254	8/2014
WO	2014/122257	8/2014
WO	2014/122260	8/2014

OTHER PUBLICATIONS

Young, Lee W., International Search Report, PCT/US2014/29446, dated Aug. 5, 2014, International Search Authority / US.

* cited by examiner

Primary Examiner — Ricky Pham
(74) *Attorney, Agent, or Firm* — McDonald Hopkins LLC

(57) CLAIM

The ornamental design of a blending system, as shown and described.

DESCRIPTION

FIG. 1 is a perspective view of a portion of a blending system showing our new design;
FIG. 2 is a front view thereof;
FIG. 3 is a rear view thereof;
FIG. 4 is a first side view thereof;
FIG. 5 is a second side view thereof;
FIG. 6 is a top view thereof; and,
FIG. 7 is a bottom view thereof.
The broken lines in the figures are included for the purpose of illustrating portions of a blending system and form no part of the claimed design.

1 Claim, 4 Drawing Sheets

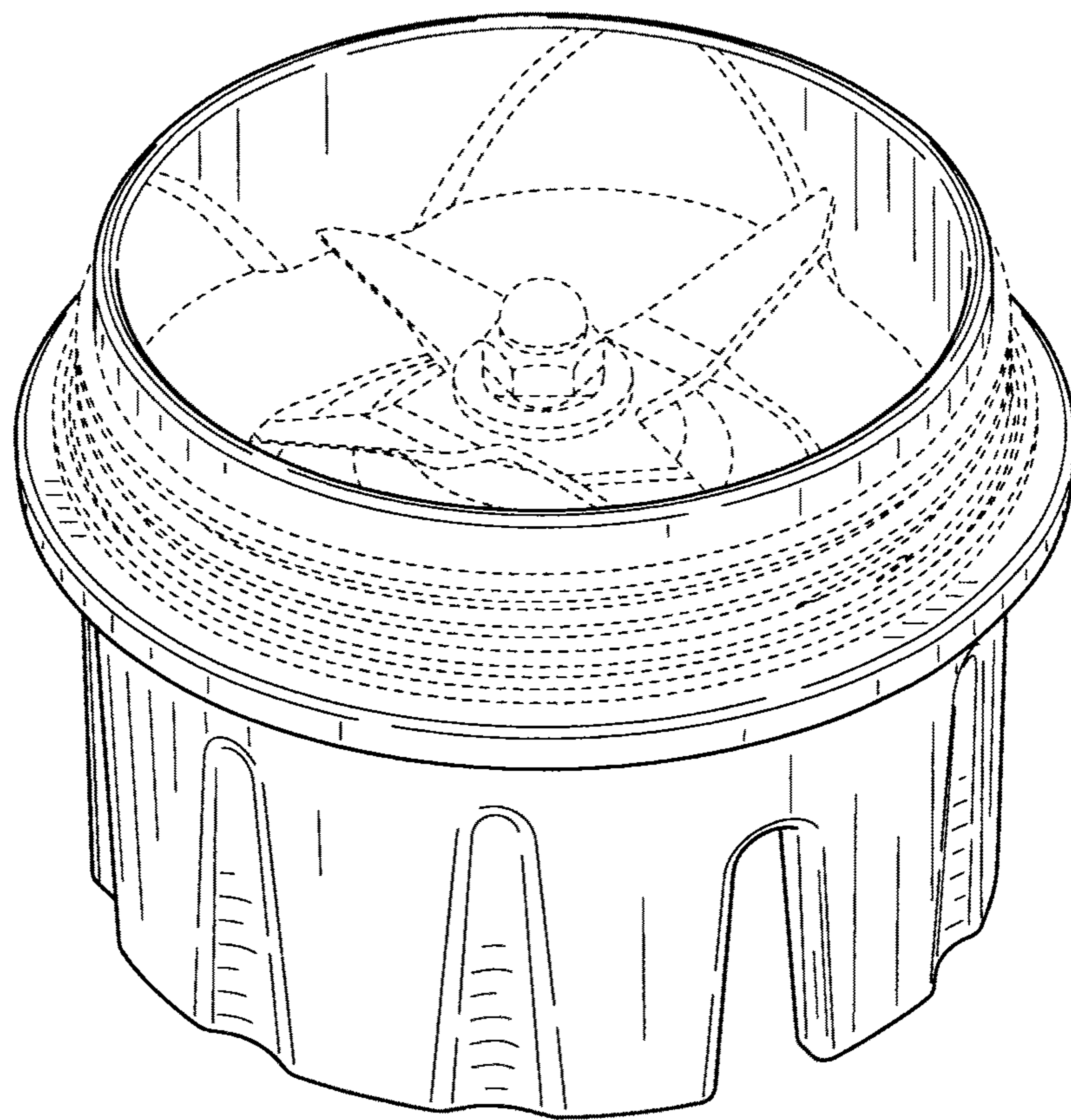

FIG. 1

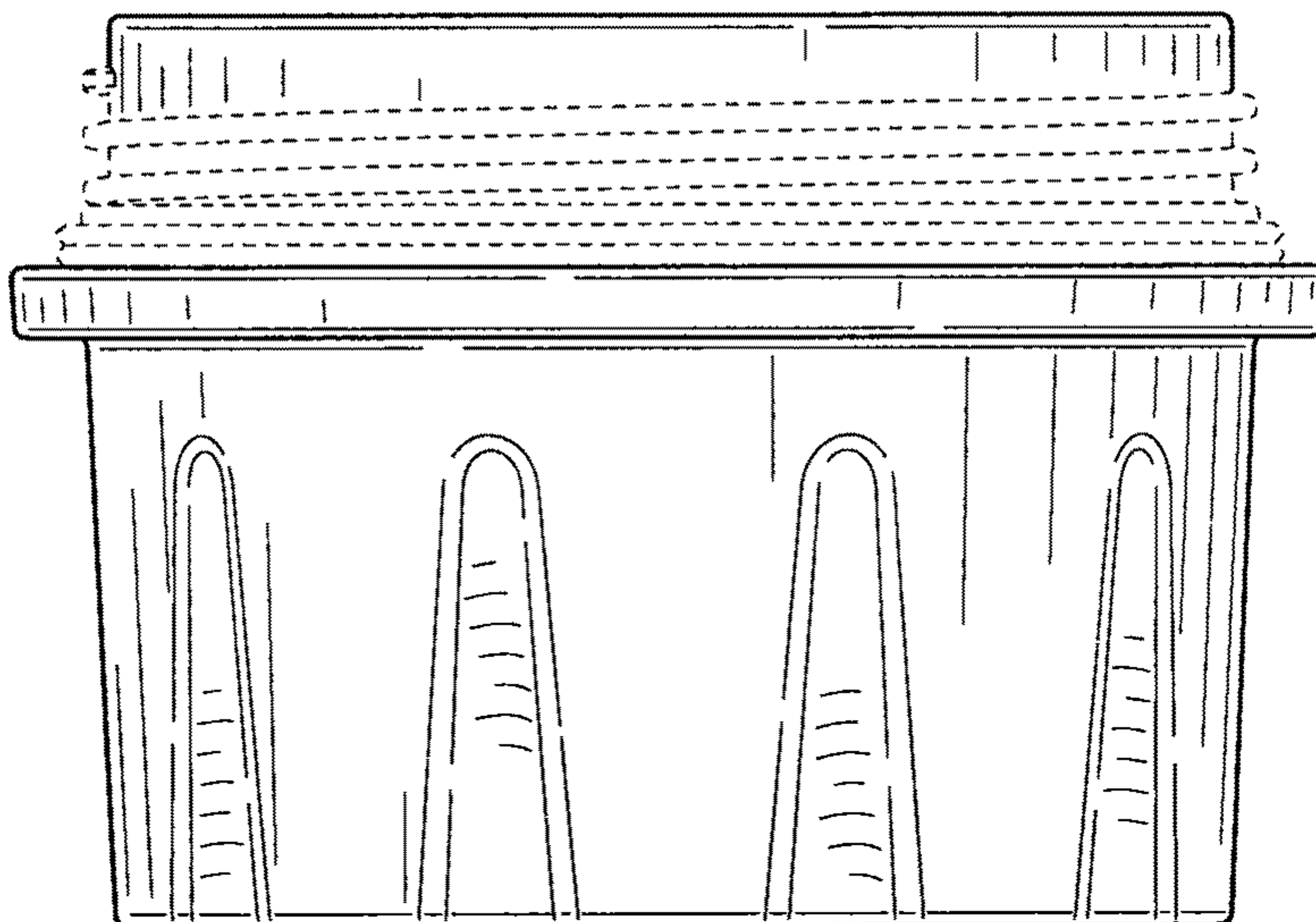

FIG. 2

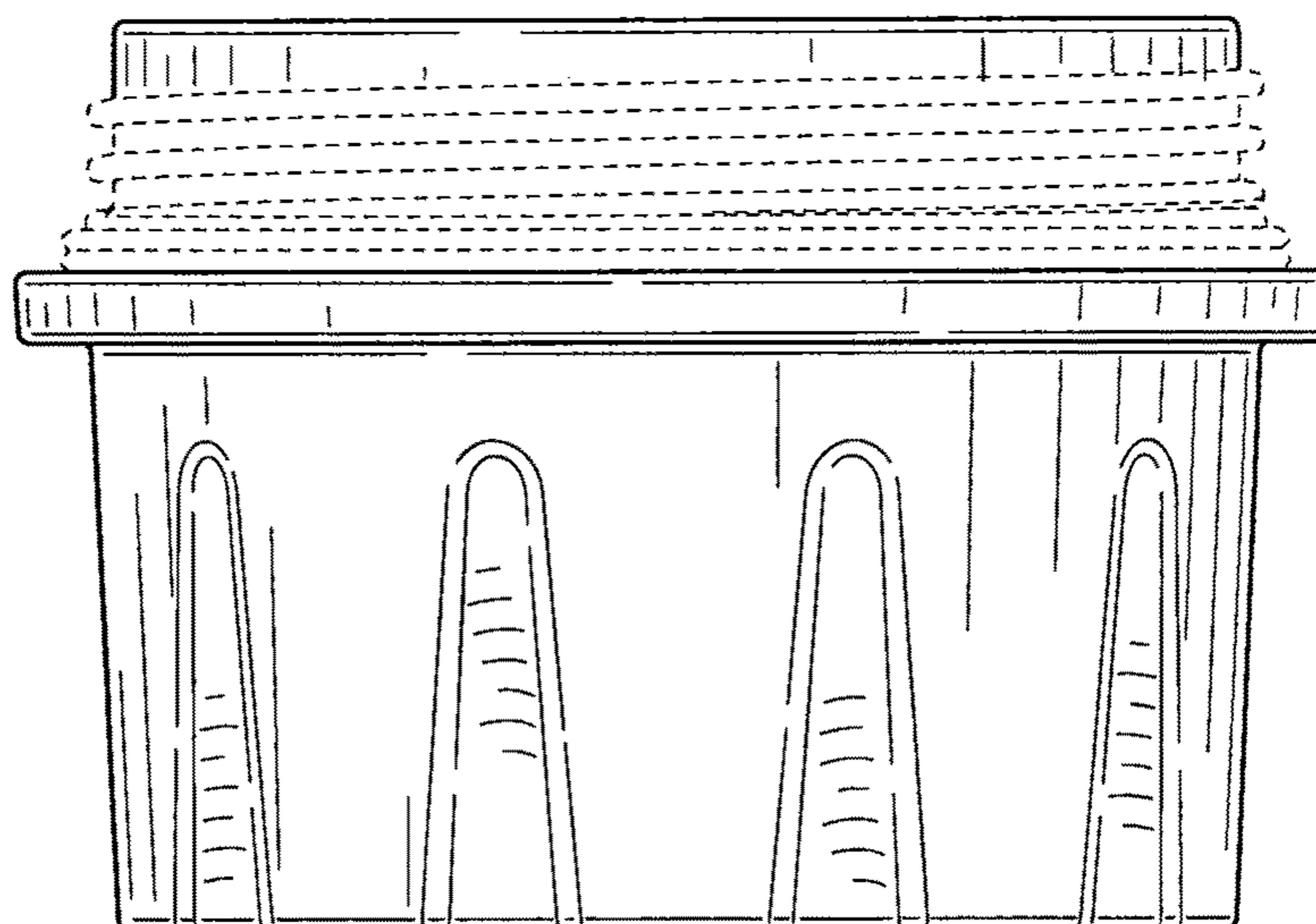

FIG. 3

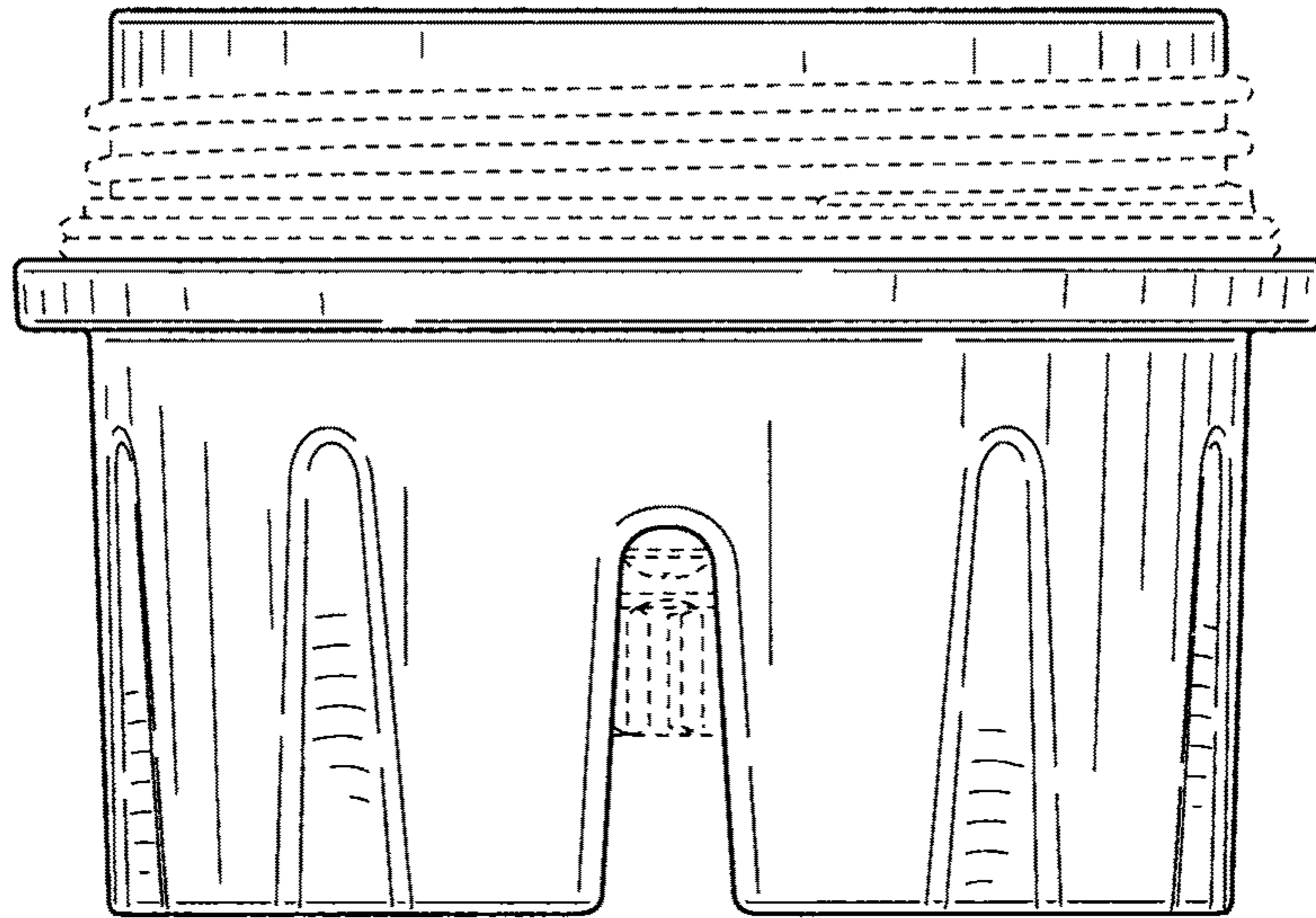

FIG. 4

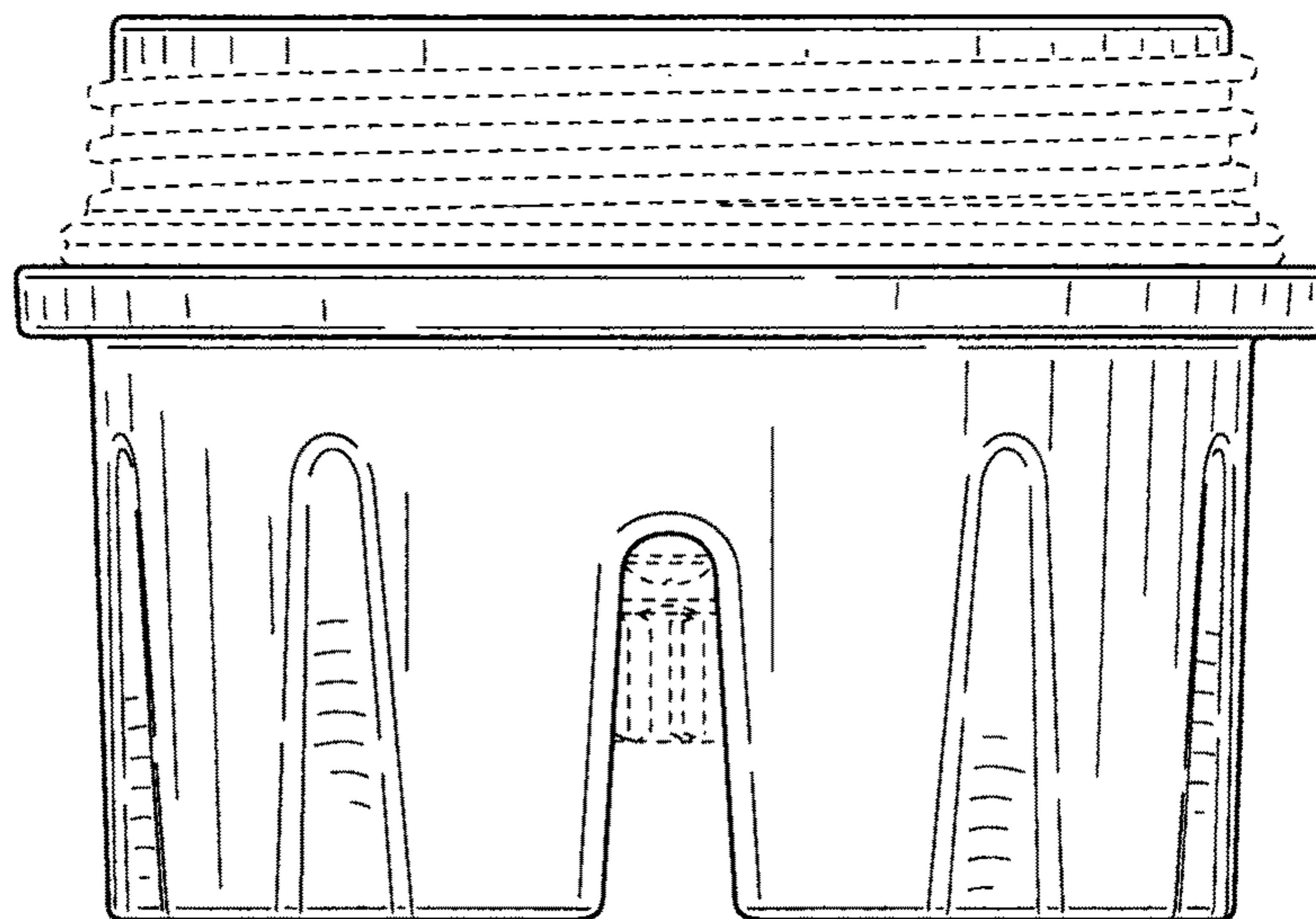

FIG. 5

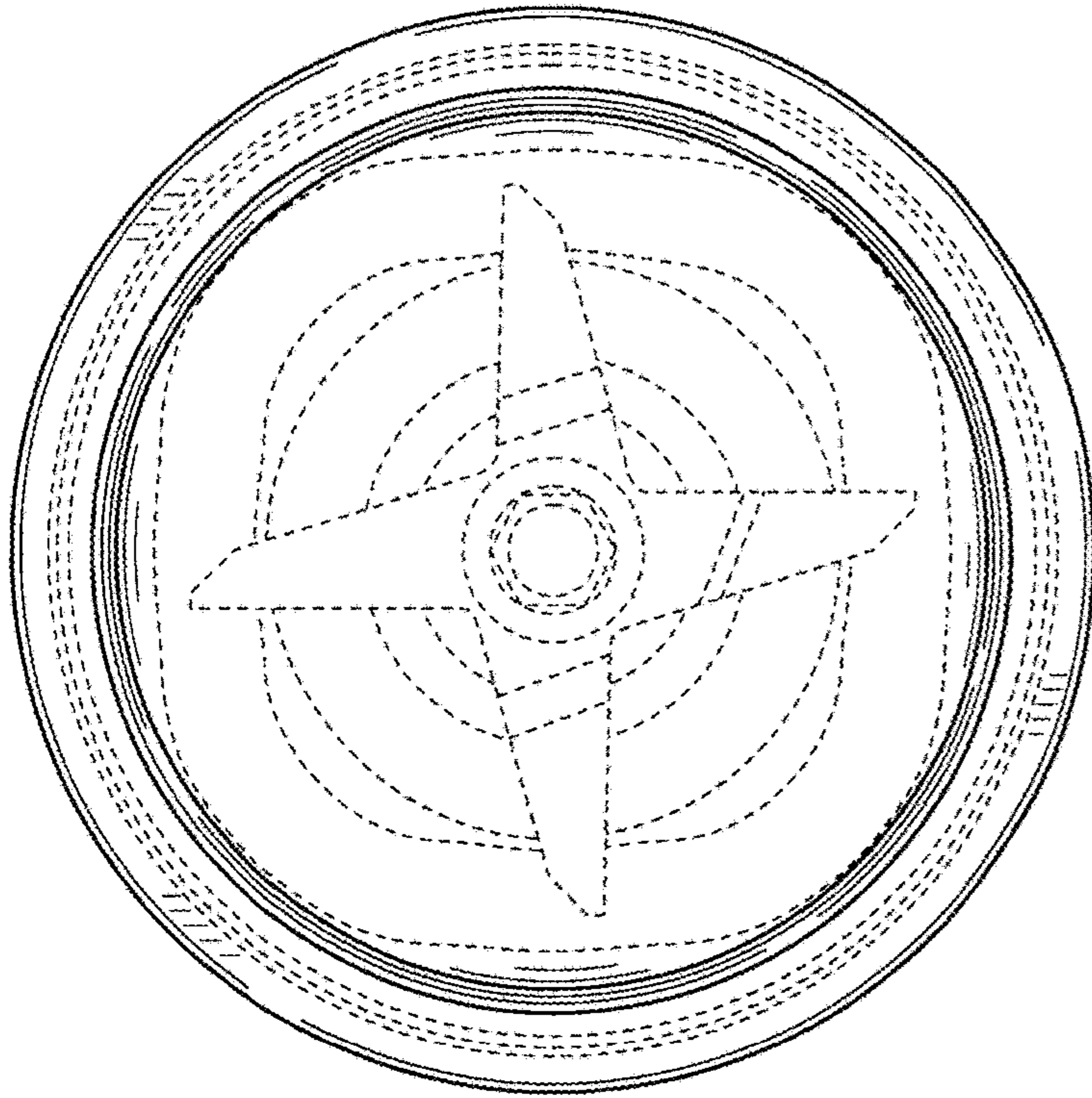

FIG. 6

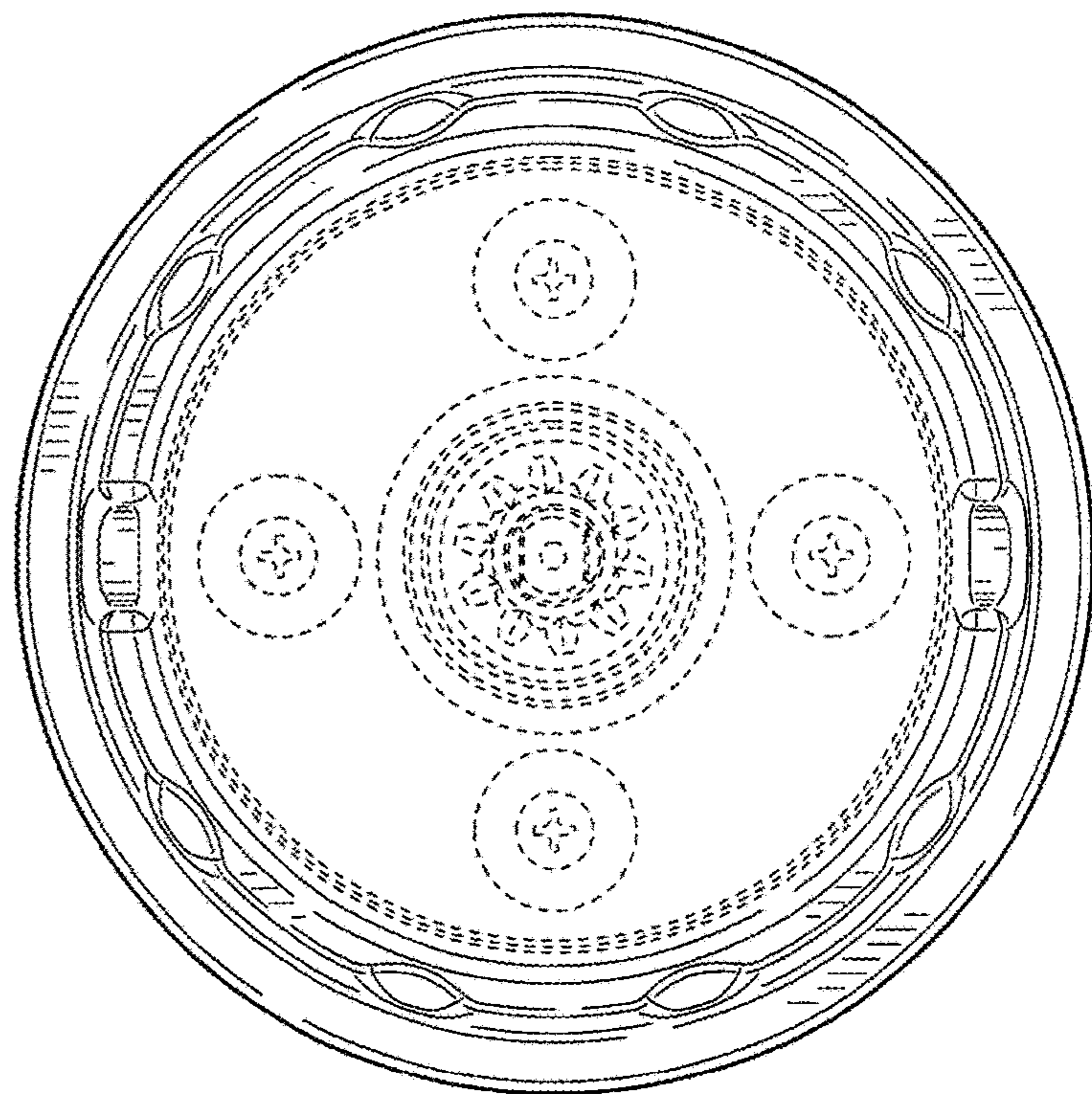

FIG. 7