



US00D878631S

(12) **United States Design Patent**
Cott et al.

(10) **Patent No.:** **US D878,631 S**
(45) **Date of Patent:** **** *Mar. 17, 2020**

(54) **BRIDGE PORTION**

- (71) Applicants: **thyssenkrupp AG**, Essen (DE);
ThyssenKrupp Steel Europe AG,
Duisburg (DE)
- (72) Inventors: **Andreas Cott**, Düsseldorf (DE); **Ingo Rogner**, Ingolstadt (DE); **Lothar Pathberg**, Moers (DE); **Marcus Rauhut**, Muelheim (DE); **Erik Hilfrich**, Düsseldorf (DE); **Michael Brügg Brock**, Rosendahl (DE); **Ralf Stegmeyer**, Medebach (DE); **Stephan Drewes**, Mönchengladbach (DE); **Thomas Flaskamp**, Duisburg (DE)

- (73) Assignees: **thyssenkrupp AG** (DE);
ThyssenKrupp Steel Europe AG (DE)

(*) Notice: This patent is subject to a terminal disclaimer.

(**) Term: **15 Years**

(21) Appl. No.: **29/608,233**

(22) Filed: **Jun. 20, 2017**

(30) **Foreign Application Priority Data**

Dec. 20, 2016 (EM) 003529247

(51) **LOC (12) Cl.** **25-03**

(52) **U.S. Cl.**
USPC **D25/1; D25/62**

(58) **Field of Classification Search**
USPC D25/1, 3, 35, 38.1, 43, 44, 62, 63;
D21/814, 818-822, 826, 506; D34/32;
14/4, 12

(Continued)

(56) **References Cited**

U.S. PATENT DOCUMENTS

- 14,313 A * 2/1856 Guiou E01D 15/133
14/13
- D180,058 S * 4/1957 Bleil D21/506

(Continued)

FOREIGN PATENT DOCUMENTS

- AT 00059194-0001 7/2006
- CN 303845233 * 12/2015

(Continued)

OTHER PUBLICATIONS

Ponte della Musica, Nov. 1, 2011, Archdaily, <https://www.archdaily.com/179789/ponte-della-musica-buro-happold> (Year: 2011).*

(Continued)

Primary Examiner — Brett Miller

(74) *Attorney, Agent, or Firm* — Polsinelli PC

(57) **CLAIM**

The ornamental design for a bridge portion, as shown and described.

DESCRIPTION

FIG. 1 is a perspective view of the bridge portion;
 FIG. 2 is a top view of the bridge portion;
 FIG. 3 is an end view of the bridge portion;
 FIG. 4 is a side view of the bridge portion;
 FIG. 5 is a bottom view of the bridge portion;
 FIG. 6 is a perspective view of a second embodiment of the bridge portion;
 FIG. 7 is a top view of the second embodiment of the bridge portion;
 FIG. 8 is an end view of the second embodiment of the bridge portion;
 FIG. 9 is a side view of the second embodiment of the bridge portion; and,
 FIG. 10 is a bottom view of the second embodiment of the bridge portion.

1 Claim, 10 Drawing Sheets

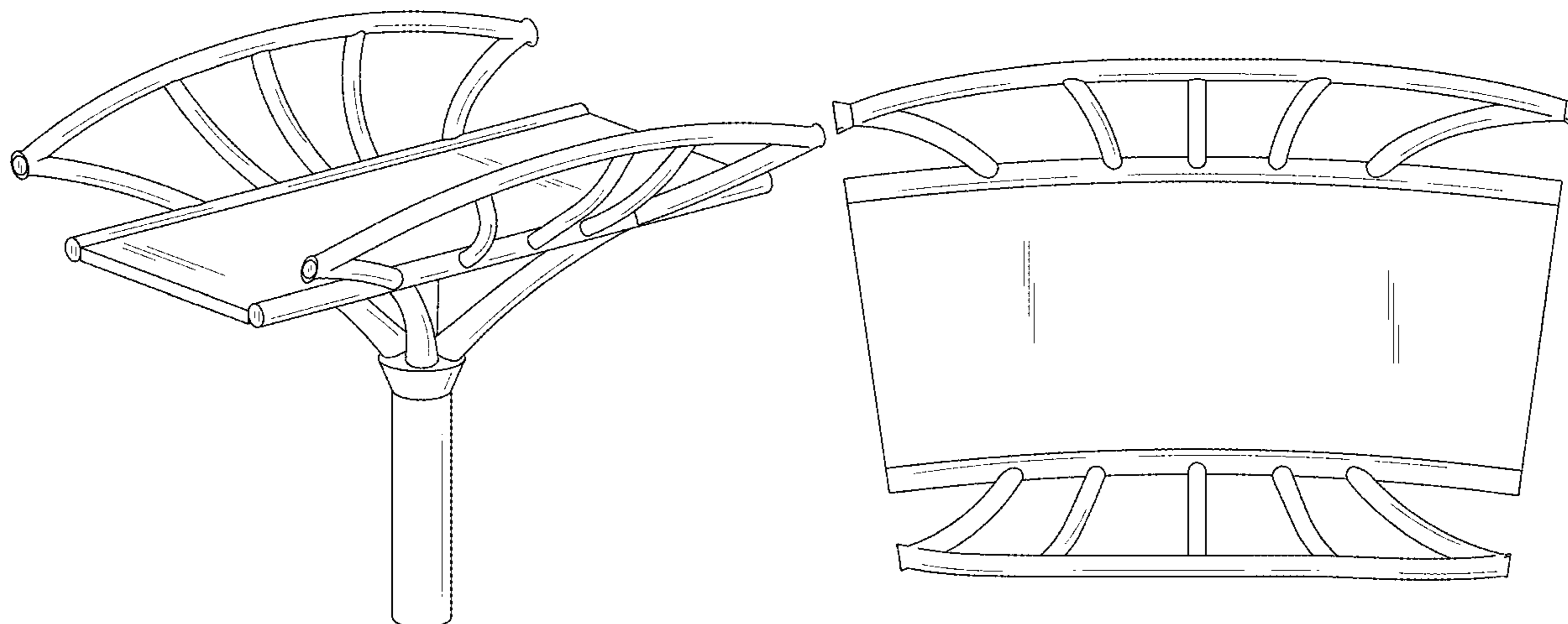

(58) **Field of Classification Search**
 CPC E01D 1/00; E01D 6/00; E01D 6/02; E01D
 12/00; E01D 15/133; E01D 19/10; E01D
 19/103; E04H 1/002; E04H 2011/005;
 E04H 2011/007
 See application file for complete search history.

(56) **References Cited**

U.S. PATENT DOCUMENTS

D524,897 S * 7/2006 VanDeusen D21/820
 7,607,186 B1 * 10/2009 Mitchell E04F 11/002
 14/69.5
 D609,363 S * 2/2010 Segall D25/1
 2004/0151541 A1 * 8/2004 Occhiolini E01D 6/00
 404/6
 2006/0272110 A1 * 12/2006 de la Chevrotiere E01D 6/00
 14/2.4
 2007/0163058 A1 * 7/2007 Homsj E01D 19/103
 14/77.1
 2011/0197378 A1 * 8/2011 De La Chevrotiere ... E01D 6/00
 14/69.5
 2013/0055511 A1 * 3/2013 McGivern E04F 11/002
 14/69.5
 2014/0345069 A1 * 11/2014 Tirimanna E01D 15/133
 14/73.1
 2017/0191232 A1 * 7/2017 Wise E01D 15/133
 2018/0100311 A1 * 4/2018 Bergmeyer E01D 1/00

FOREIGN PATENT DOCUMENTS

CN 303901082 * 7/2016
 DE 49502897-0001 9/1995
 DE 49610618-0001 6/1997
 DE 49610618-0002 6/1997
 DE 49610618-0003 6/1997
 DE 49803425-0001 2/1999
 DE 40706017-0001 2/2008
 DE 40706017-0002 2/2008
 DE 402013002781-0001 12/2013
 DE 402013002781-0002 12/2013
 DE 402015200681-0001 5/2016
 DE 402015200681-0002 5/2016
 DE 402015200681-0003 5/2016
 DE 402016000673-0001 5/2016
 DE 402016000673-0002 5/2016
 EM 00401708-0001 11/2005

EM	00643556-0001	2/2007
EM	01581513-0001	8/2009
EM	01598459-0001	8/2009
EM	01598459-0002	8/2009
EM	01598459-0003	8/2009
EM	01818618-0001	2/2011
EM	01854985-0001	5/2011
EM	01280408-0001	7/2011
EM	01082614-0007	8/2011
EM	01082614-0008	8/2011
EM	01965237-0003	1/2012
EM	02088377-0001	8/2012
EM	02492256-0001	7/2014
EM	02492256-0002	8/2014
EM	02627687-0001	2/2015
EM	02650929-0001	3/2015
EM	02914127-0001	12/2015
EM	01447262-0001	5/2016
EM	03300367-0001	8/2016
EM	02465625-0001	12/2016
EM	02465625-0002	12/2016
GB	03012853-0001	8/2003
GB	03023701-0001	2/2006
GB	04001070-0001	6/2007
GB	04005185-0001	1/2008
GB	04039251-0001	4/2015
IR	00018372-0001	2/1991
IR	00025445-0001	5/1993
IR	00028394-0001	3/1994
IR	00077872-0001	3/2012
IR	00077872-0002	3/2012
IR	00077872-0003	3/2012
KR	300729161.0001	* 7/2013

OTHER PUBLICATIONS

U.S. Appl. No. 29/608,222; Bridge Portion; filed Jun. 20, 2017; (40 pages).
 U.S. Appl. No. 29/608,252; Bridge Portion; filed Jun. 20, 2017; (37 pages).
 U.S. Appl. No. 29/608,201; Bridge Portion; filed Jun. 20, 2017; (37 pages).
 U.S. Appl. No. 29/608,186; Bridge Portion; filed Jun. 20, 2017; (38 pages).
 U.S. Appl. No. 29/608,202; Bridge Portion; filed Jun. 20, 2017; (38 pages).

* cited by examiner

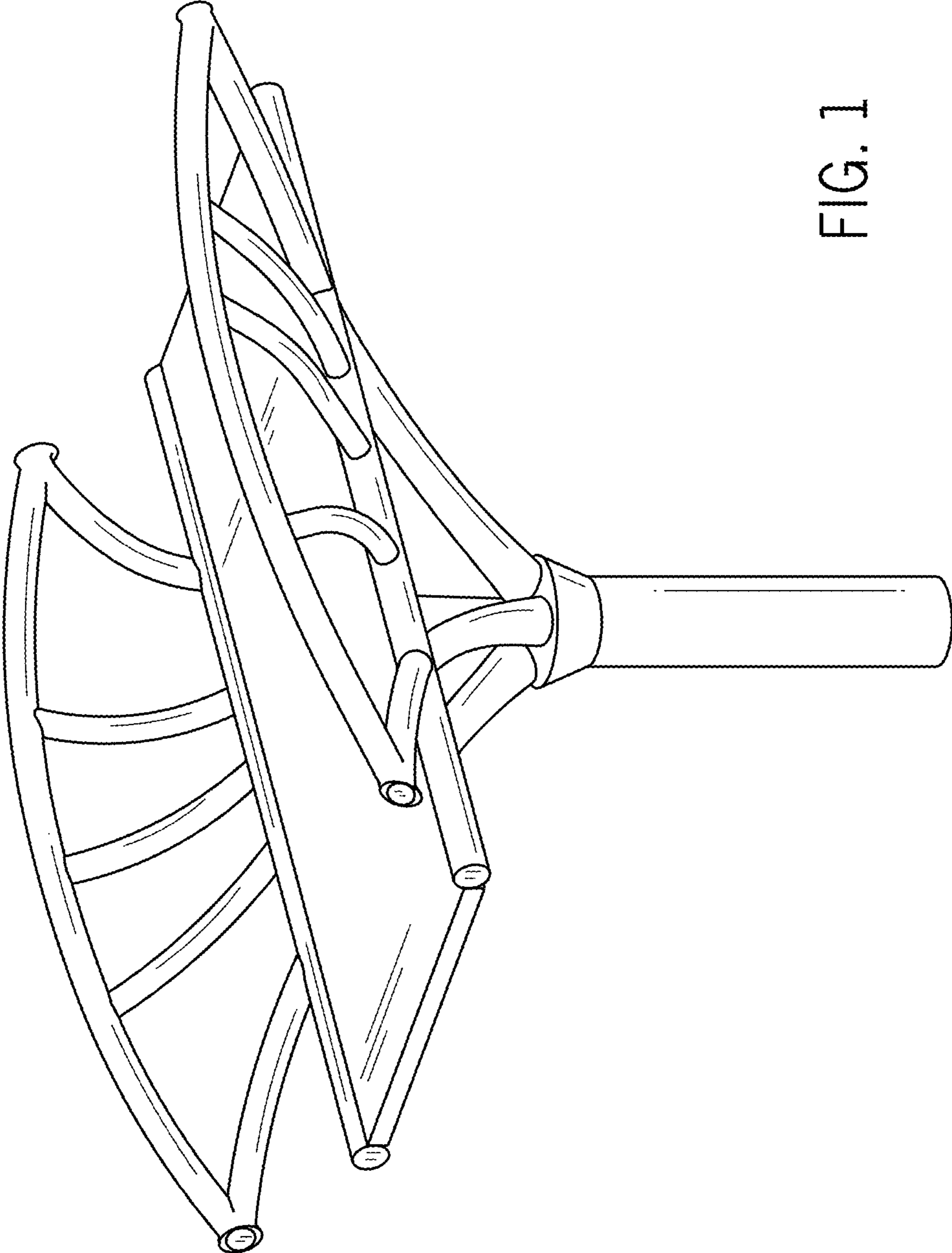

FIG. 1

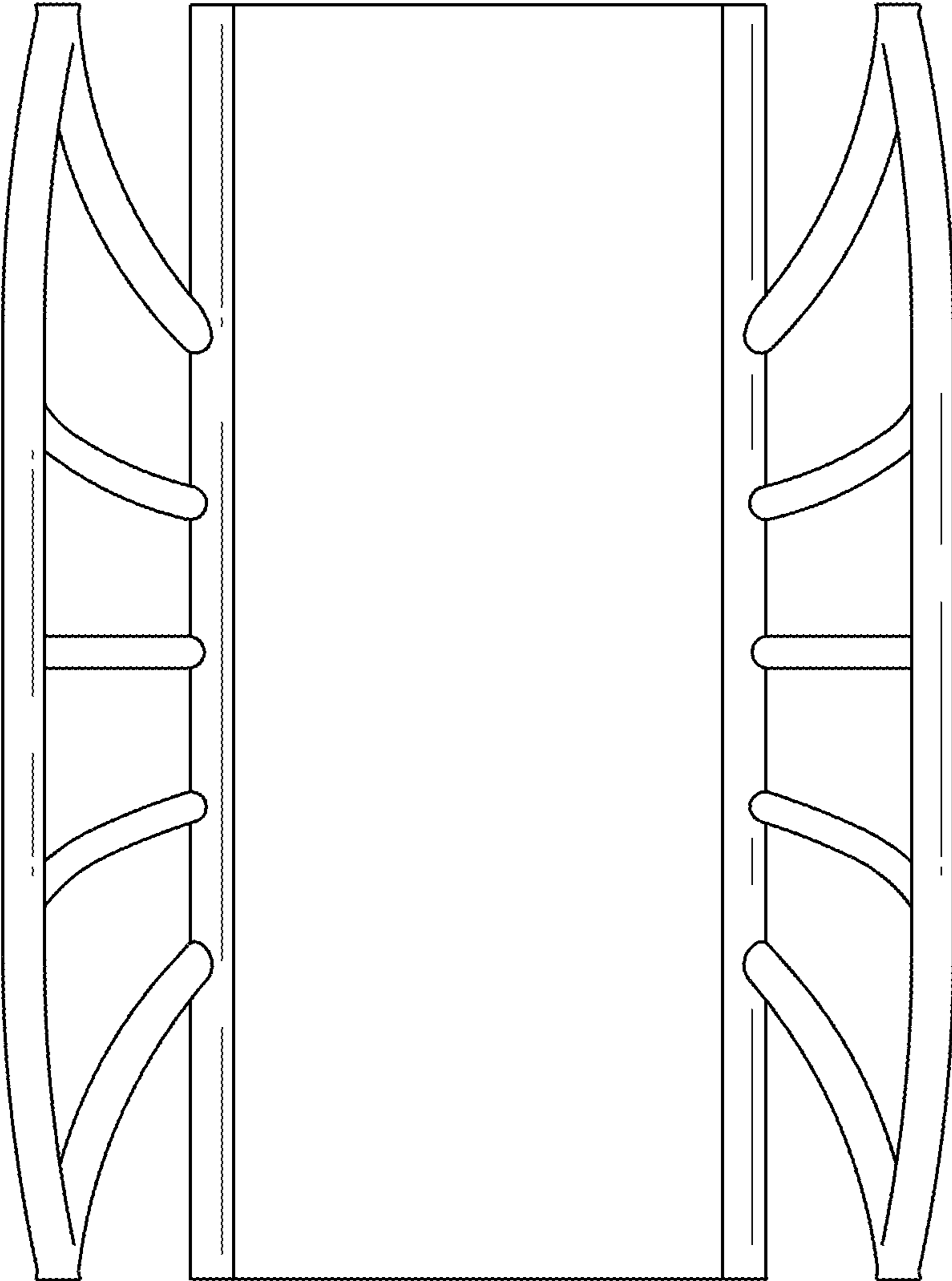

FIG. 2

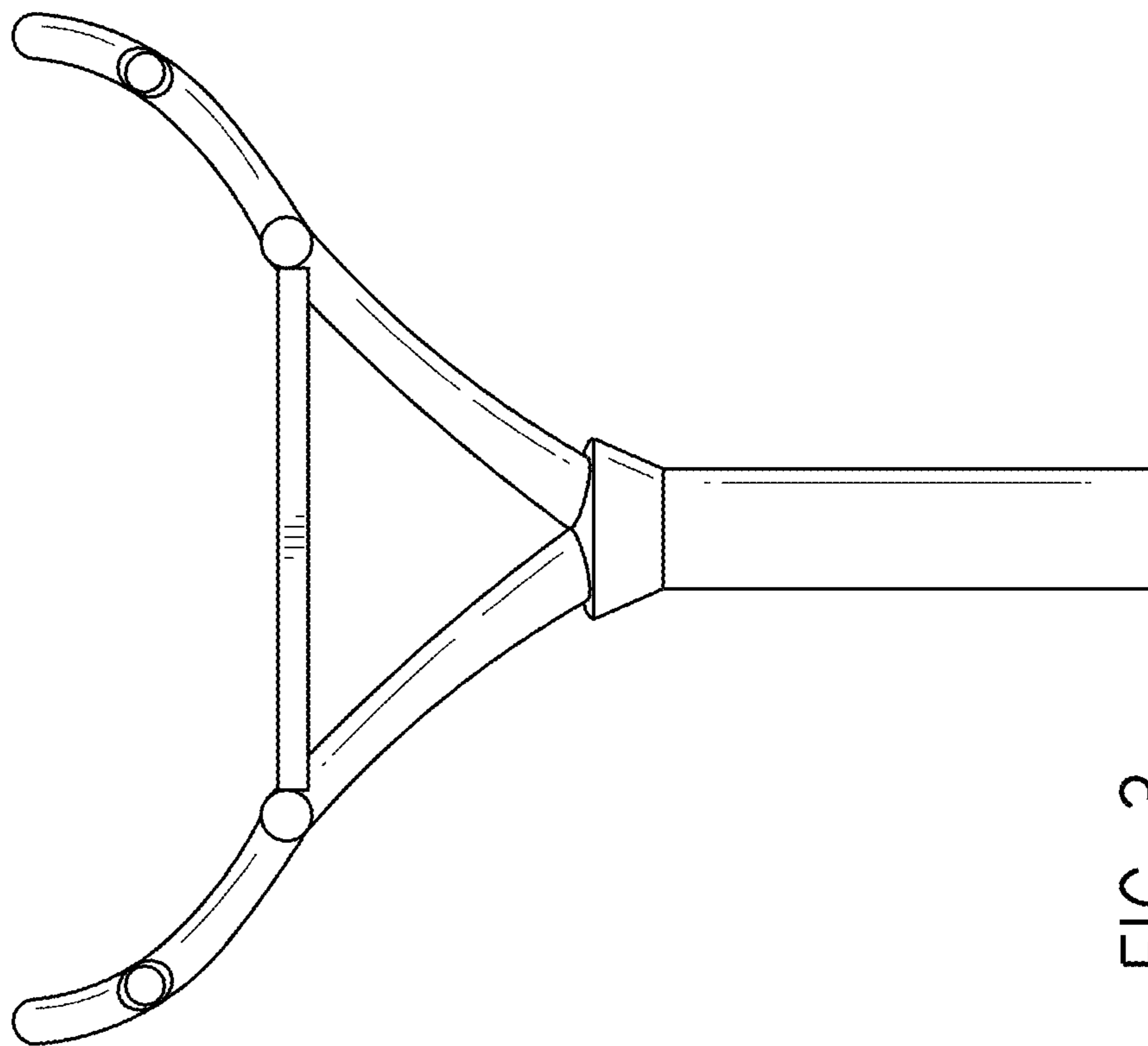

FIG. 3

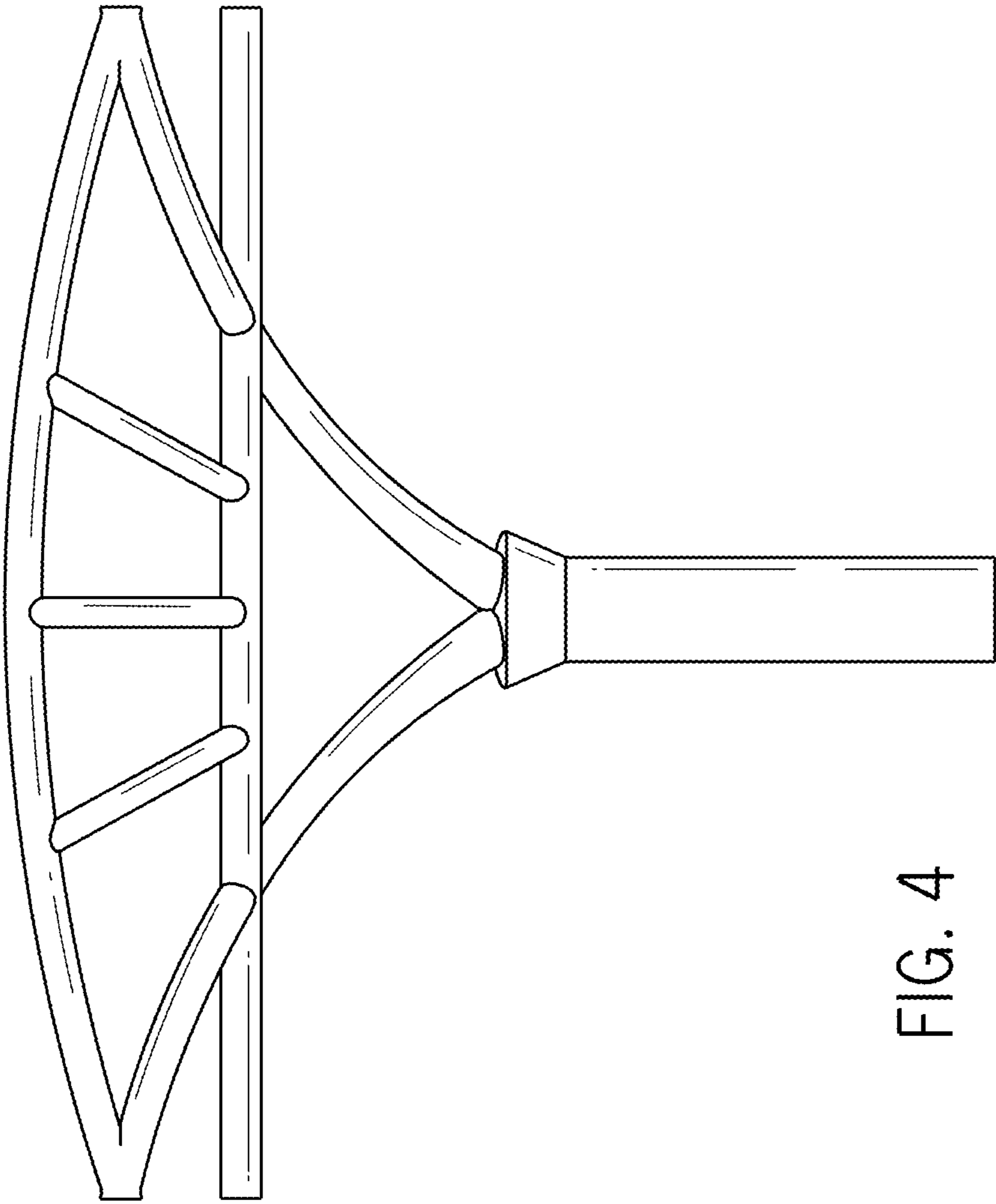

FIG. 4

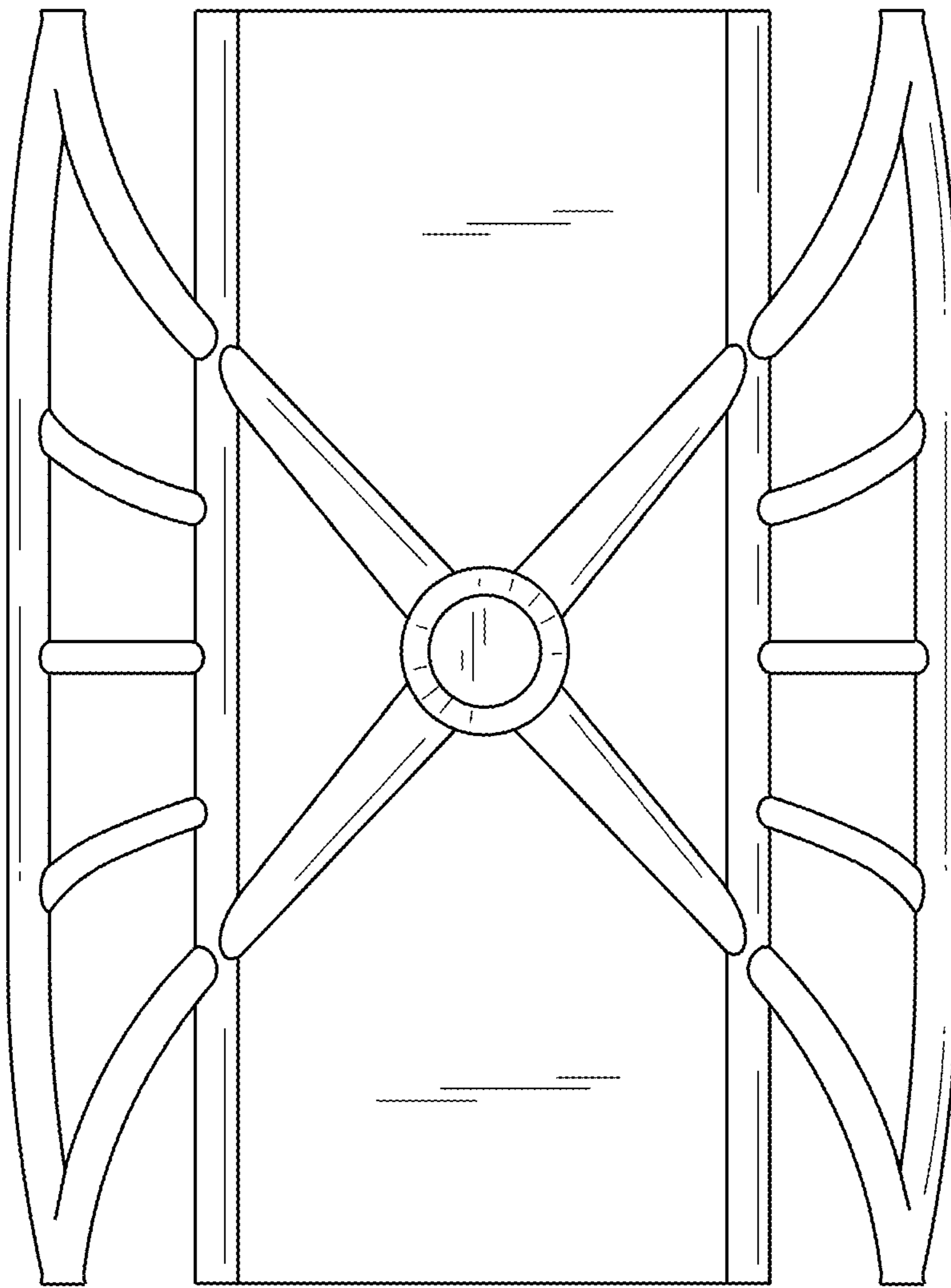

FIG. 5

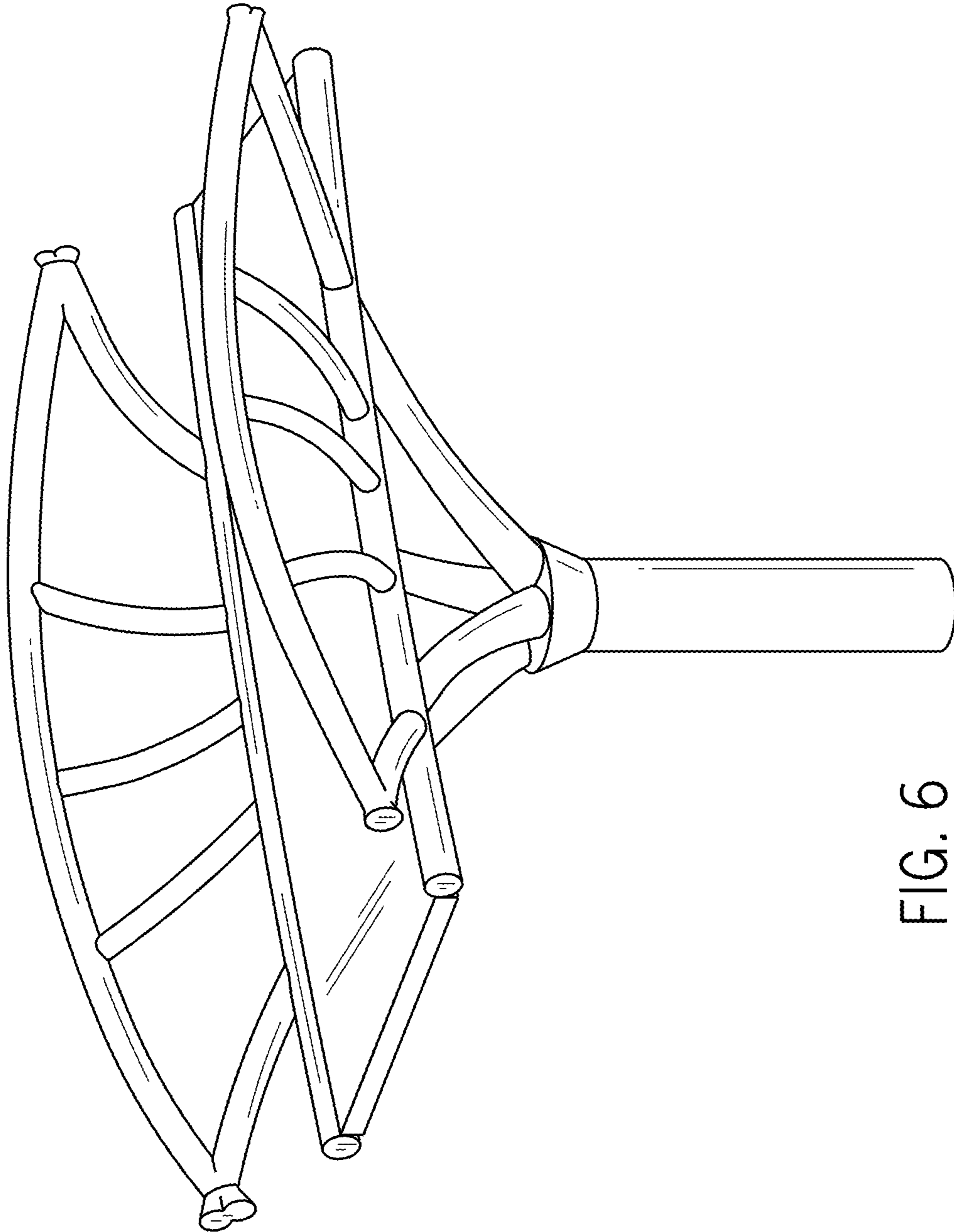

FIG. 6

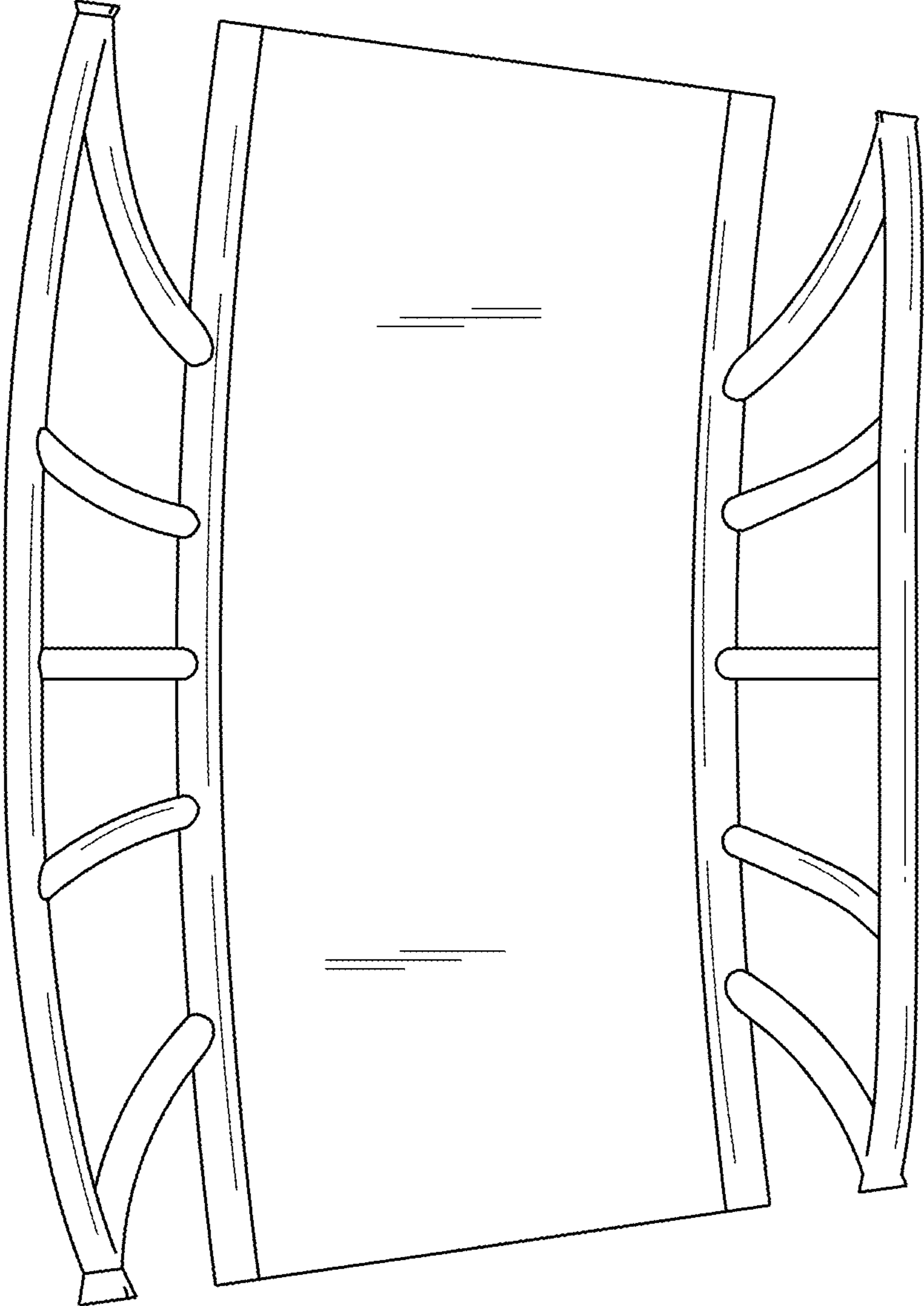

FIG. 7

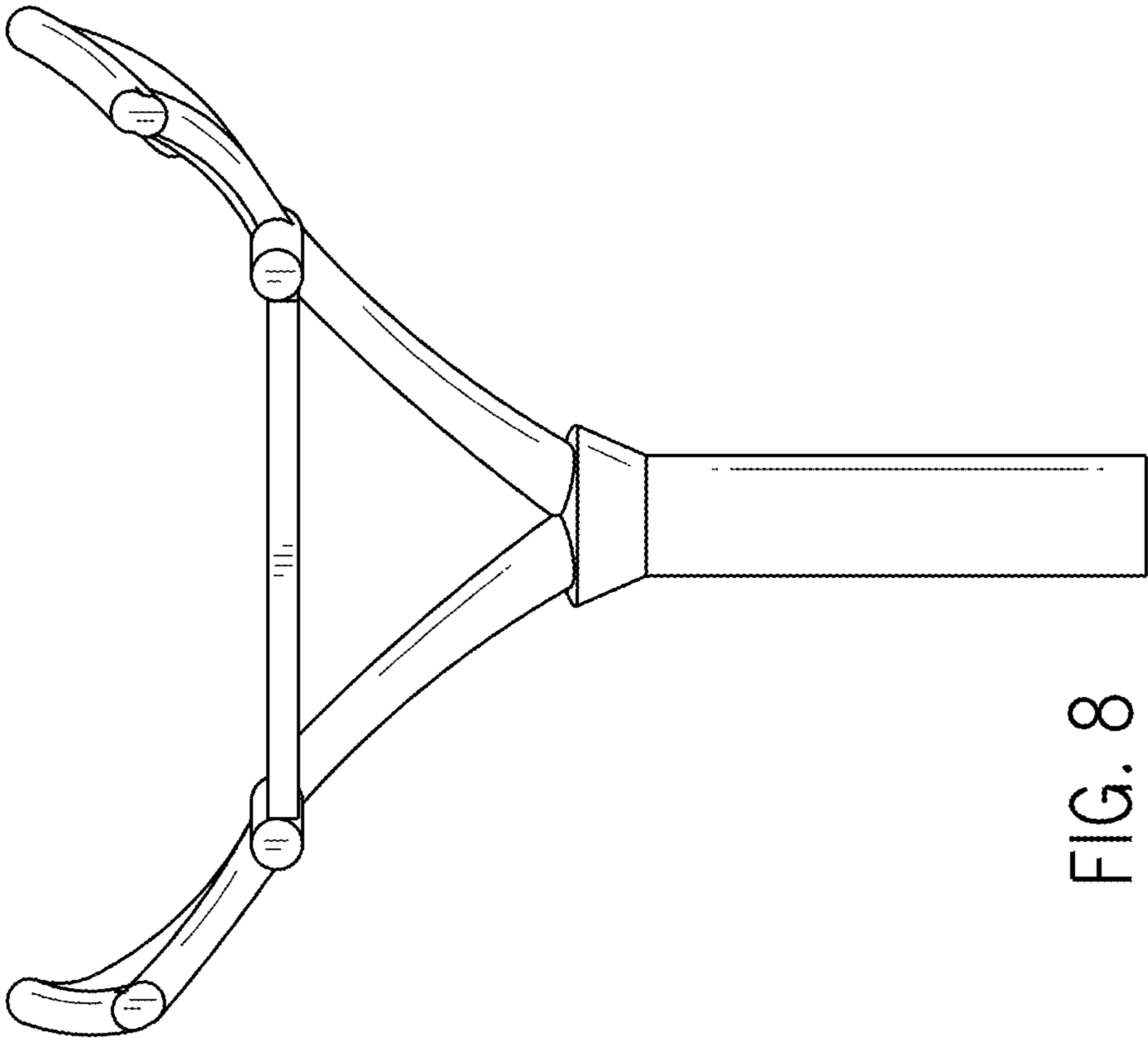

FIG. 8

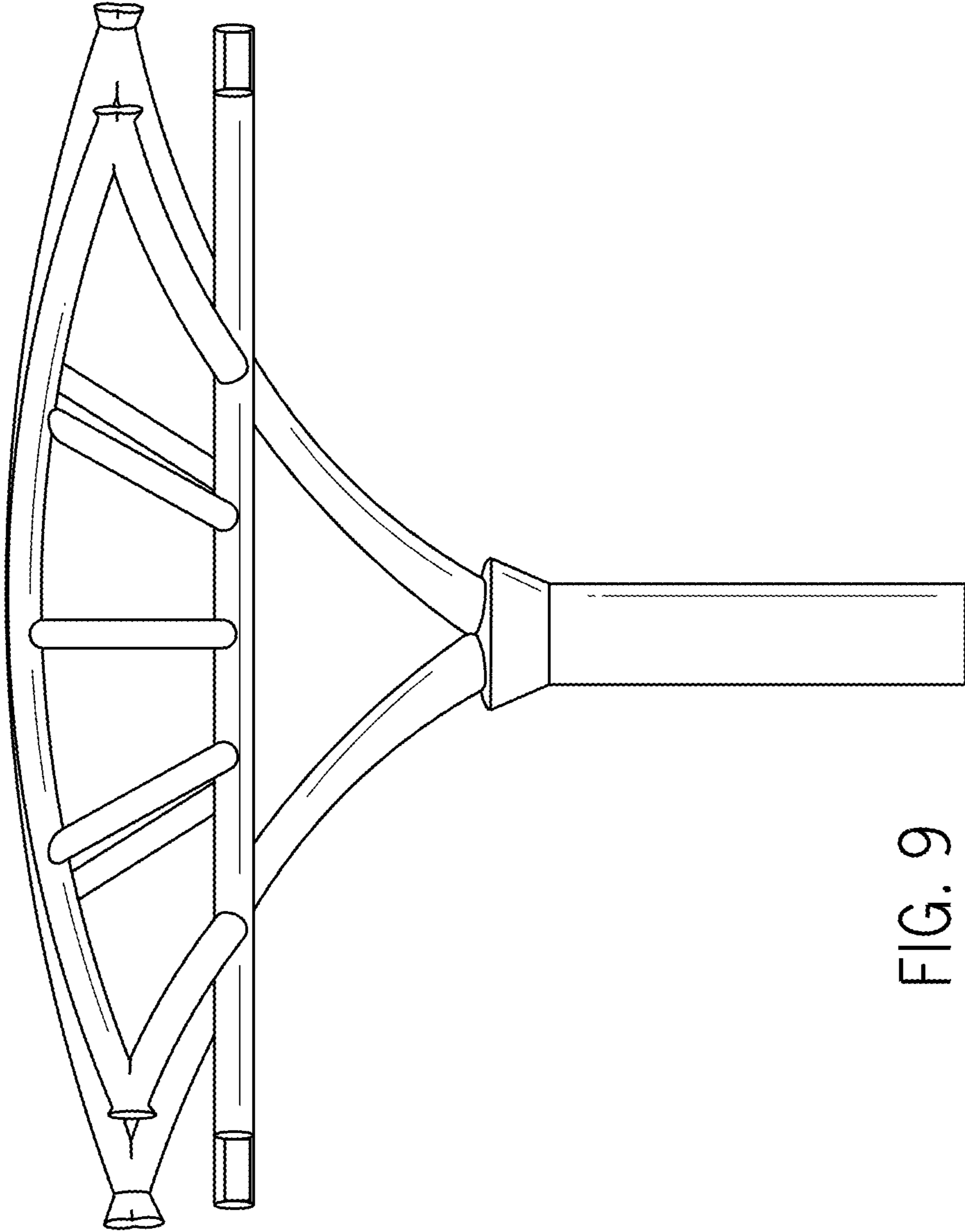

FIG. 9

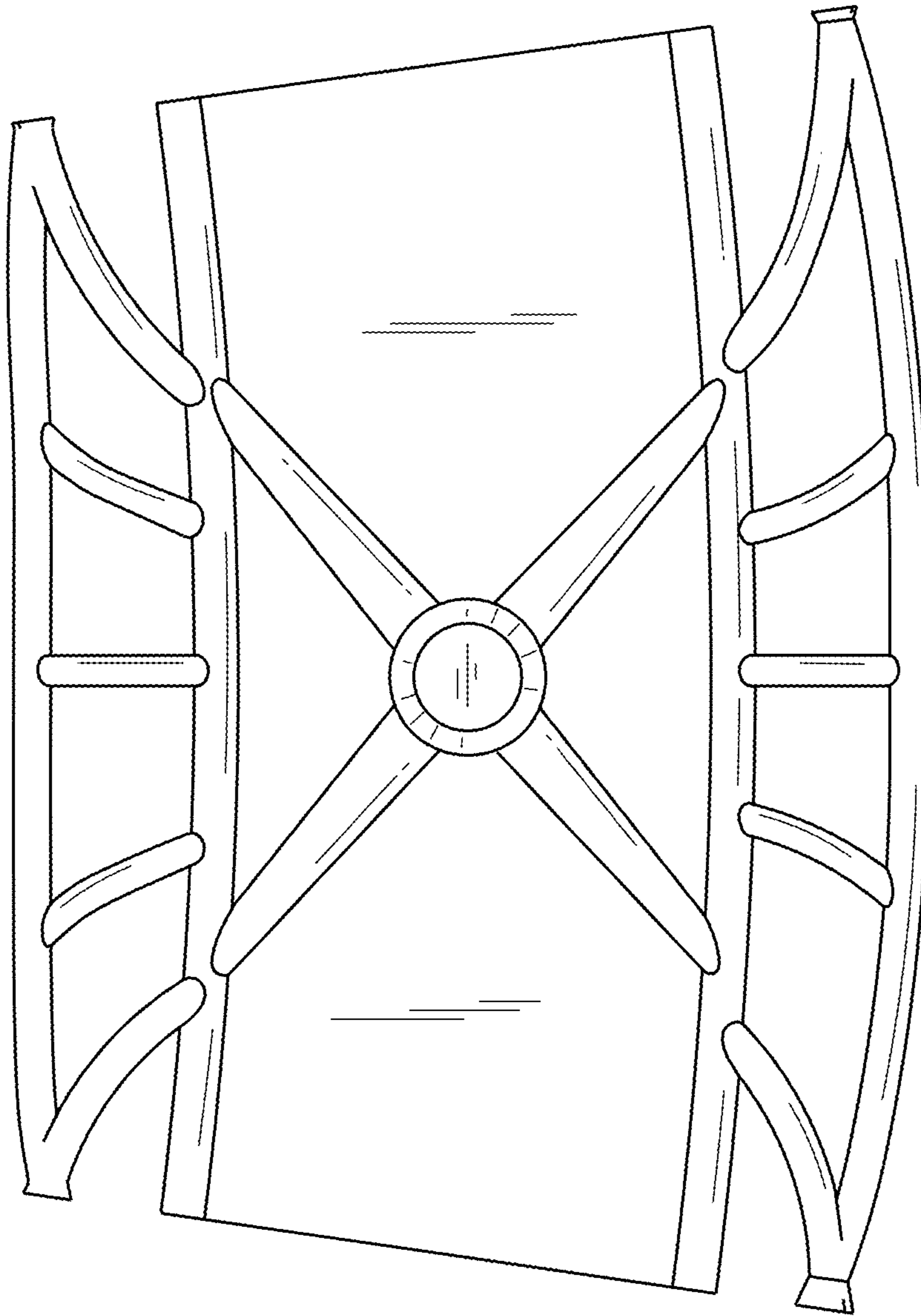

FIG. 10