



US00D878585S

(12) **United States Design Patent**
Garcia

(10) **Patent No.:** **US D878,585 S**
(45) **Date of Patent:** **** Mar. 17, 2020**

(54) **END EFFECTOR COUPLER STEM**

(71) Applicant: **Zimmer Biomet CMF and Thoracic, LLC**, Jacksonville, FL (US)

(72) Inventor: **Saddy Garcia**, St. Augustine, FL (US)

(73) Assignee: **Zimmer Biomet CMF and Thoracic, LLC**, Jacksonville, FL (US)

(**) Term: **15 Years**

(21) Appl. No.: **29/640,121**

(22) Filed: **Mar. 12, 2018**

(51) **LOC (12) Cl.** **24-02**

(52) **U.S. Cl.**
USPC **D24/145; D24/158**

(58) **Field of Classification Search**
USPC D24/145, 158, 184–186, 232, 127–128;
600/228–229; 248/176.1, 205.1
CPC A61B 90/50; A61B 2017/291; A61B
17/2909

See application file for complete search history.

(56) **References Cited**

U.S. PATENT DOCUMENTS

2,752,116 A	6/1956	Minnis	
3,910,538 A	10/1975	Baitella	
4,143,652 A *	3/1979	Meier	A61B 17/02 600/229
4,402,481 A	9/1983	Sasaki	
D382,639 S *	8/1997	Musgrave	D24/108
5,779,209 A	7/1998	Rello	
6,210,325 B1 *	4/2001	Bartie	A61B 17/02 600/229

(Continued)

FOREIGN PATENT DOCUMENTS

CN	107614817 A	1/2018
DE	102015104810 A1	9/2016

(Continued)

OTHER PUBLICATIONS

“European Application Serial No. 16773696.6, Extended European Search Report dated Nov. 19, 2018”, 8 pgs.

(Continued)

Primary Examiner — Wan Laymon

(74) *Attorney, Agent, or Firm* — Schwegman Lundberg & Woessner, P.A.

(57) **CLAIM**

The ornamental designs for an end effector coupler stem, as shown and described.

DESCRIPTION

FIG. 1 is perspective view of an end effector coupler stem, showing an embodiment of my new design; FIG. 2 is a right-side planar view thereof; FIG. 3 is a left-side planar view thereof; FIG. 4 is a front planar view thereof; FIG. 5 is a back planar view thereof; FIG. 6 is a top planar view thereof; and FIG. 7 is a bottom planar view thereof. FIG. 8 is a top-left-perspective view of an end effector coupler stem, showing an embodiment of my new design; FIG. 9 is a right-side planar view thereof; FIG. 10 is a left-side planar view thereof; FIG. 11 is a front planar view thereof; FIG. 12 is a back planar view thereof; FIG. 13 is a top planar view thereof; and, FIG. 14 is a bottom planar view thereof. Subject matter shown in broken lines is environmental and forms no part of the particular embodiment of the design. However, Applicants reserve the right to claim any combination or subset of subject matter, whether shown in broken lines or solid lines, in this application or in one or more divisional applications thereof.

1 Claim, 8 Drawing Sheets

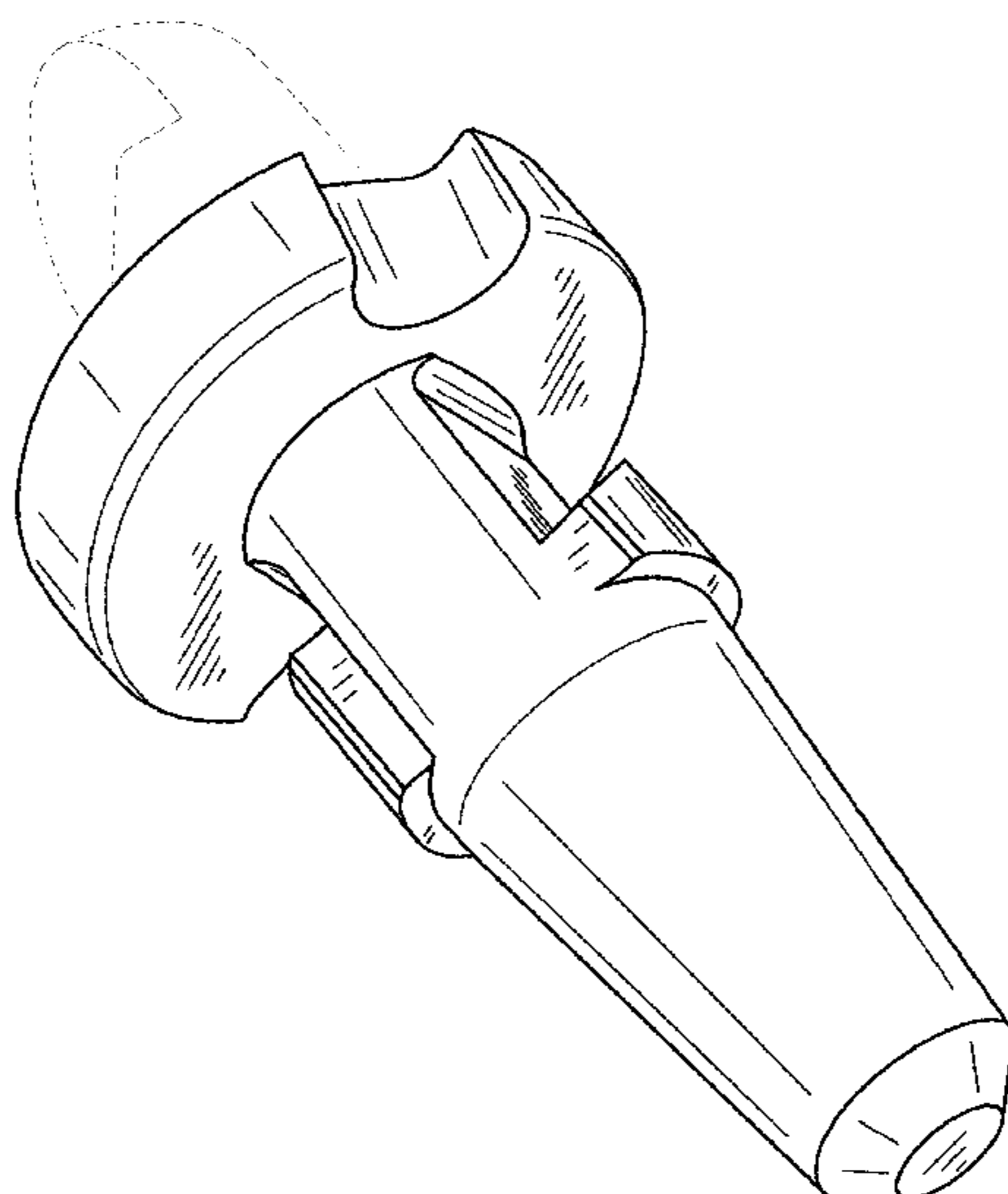

(56)

References Cited

U.S. PATENT DOCUMENTS

6,340,345	B1 *	1/2002	Lees	A61B 17/0206 600/229
6,467,362	B2	10/2002	Erikson		
6,575,653	B1	6/2003	Kräuter		
6,663,563	B1 *	12/2003	Sharratt	A61B 17/02 600/228
6,860,877	B1	3/2005	Sanchez et al.		
D602,128	S *	10/2009	Williams	D23/262
7,611,378	B1	11/2009	Brekosky et al.		
8,382,048	B2 *	2/2013	Nesper	A61B 90/50 248/160
9,592,096	B2	3/2017	Maillet et al.		
9,937,012	B2 *	4/2018	Hares	A61B 34/30
2002/0017857	A1	2/2002	Hashimoto et al.		
2002/0074472	A1	6/2002	Gaida et al.		
2002/0177857	A1	11/2002	Otsuka et al.		
2002/0188293	A1	12/2002	Manzo		
2004/0172012	A1	9/2004	Otsuka et al.		
2010/0020002	A1	1/2010	Van Woudenberg et al.		
2010/0200002	A1	8/2010	Orban, III et al.		
2011/0290855	A1	12/2011	Moore et al.		
2011/0315843	A1	12/2011	Hung		
2012/0182134	A1	7/2012	Doyle		
2012/0265240	A1	10/2012	Ganske et al.		
2013/0023735	A1 *	1/2013	Brown	A61B 90/50 600/229
2013/0187022	A1	7/2013	Duportal et al.		
2014/0379038	A1	12/2014	Dogramadzi et al.		
2015/0100066	A1	4/2015	Kostrzewski et al.		
2016/0081753	A1	3/2016	Kostrzewski		
2016/0151120	A1	6/2016	Kostrzewski et al.		
2016/0270780	A1	9/2016	Hall et al.		
2017/0340210	A1	11/2017	Chuang		
2017/0340389	A1	11/2017	Otto et al.		
2017/0360521	A1	12/2017	Johnson		
2018/0116758	A1	5/2018	Schlosser et al.		
2019/0167356	A1	6/2019	Britton et al.		
2019/0274665	A1 *	9/2019	Garcia	A61B 90/50
2019/0274777	A1 *	9/2019	Garcia	A61B 90/50
2019/0274778	A1	9/2019	Billard et al.		
2019/0274780	A1	9/2019	Nowatschin et al.		

FOREIGN PATENT DOCUMENTS

EP	2777539	A2	9/2014
EP	2143372		12/2014
JP	S63280911	A	11/1988
JP	63280911	A	11/1998
JP	2018509273		4/2018
WO	9639944	A1	12/1996
WO	2016160272	A1	10/2016
WO	2017017443		2/2017
WO	2017151887	A1	9/2017
WO	2019177567		9/2019
WO	2019177569		9/2019
WO	2019177570		9/2019

OTHER PUBLICATIONS

“Anatomical Shoulder Fracture System”, Zimmer Surgical Technique, 97-4223-003-00 Rev. 1, (2005), 24 pgs.
 “Comprehensive Segmental Revision System, Proximal Humeral Reconstruction, Distal Humeral Reconstruction, Total Humeral Reconstruction”, Zimmer Biomet Surgical Technique, 0097.1-US-en-REV0416, (2016), 68 pgs.
 “Anatomical Shoulder Glenoid”, Zimmer Surgical Technique, (2014), 12 pgs.
 “International Application Serial No. PCT US2018 022006, Invitation to Pay Additional Fees dated Dec. 12, 2018”, 16 pgs.
 “U.S. Appl. No. 15/560,894, Restriction Requirement dated Dec. 31, 2018”, 7 pgs.
 “International Application Serial No. PCT/US2018/021988, International Search Report dated Dec. 20, 2018”, 4 pgs.

“International Application Serial No. PCT/US2018/021988, Written Opinion dated Dec. 20, 2018”, 6 pgs.
 “International Application Serial No. PCT/US2018/022004, Invitation to Pay Additional Fees dated Dec. 19, 2018”, 15 pgs.
 “International Application Serial No. PCT US2018 022004, International Search Report dated Feb. 14, 2019”, 8 pgs.
 “International Application Serial No. PCT US2018 022004, Written Opinion dated Feb. 14, 2019”, 14 pgs.
 “International Application Serial No. PCT US2018 022006, International Search Report dated Feb. 8, 2019”, 8 pgs.
 “International Application Serial No. PCT US2018 022006, Written Opinion dated Feb. 8, 2019”, 15 pgs.
 “European Application Serial No. 16773696.6, Response dated Jun. 4, 2018 to Office Action dated Nov. 22, 2018”.
 “U.S. Appl. No. 15/560,894, Response dated Mar. 21, 2019 to Restriction Requirement dated Dec. 31, 2018”, 9 pgs.
 “European Application Serial No. 182108114, Extended European Search Report dated Apr. 12, 2019”, 7 pgs.
 “U.S. Appl. No. 15/560,894, Non Final Office Action dated May 16, 2019”, 9 pgs.
 “European Application Serial No. 16773696.6, Response dated Jun. 17, 2019 to Extended European Search Report dated Nov. 19, 2018”, 18 pgs.
 “Chinese Application Serial No. 201680027778.9, Office Action dated Jul. 12, 2019”, w English Translation, 20 pgs.
 “U.S. Appl. No. 15/560,894, Response dated Aug. 16, 2019 to Non Final Office Action dated May 16, 2019”, 11 pgs.
 “Canadian Application Serial No. 3,002,354, Office Action dated Jul. 4, 2019”, 4 pgs.
 “Unitrac Retraction and holding system for open and minimally invasive surgery”, Aesculap Surgical Technologies—Surgical Instruments, (2010), 12 pgs.
 “3840 Series Holder”, Fisso—Rail-mounted instrument holding arm / articulated, [Online]. [Accessed Oct. 16, 2017]. Retrieved from the Internet: <URL: <http://www.medicalexpo.com/prod/fisso/product-67723-681104.html>>, 3 pgs.
 “3D-Arm™”, Elekta—Minimally invasive surgery instrument holding arm, [Online]. [Accessed Oct. 16, 2017]. Retrieved from the Internet: <URL: <http://www.medicalexpo.com/prod/elekta/product-70692-509376.html>>, 8 pgs.
 “ALLY Uterine Positioning System”, Cooper Surgical, [Online]. [Accessed Oct. 16, 2017]. Retrieved from the Internet: <URL: <https://www.coopersurgical.com/Products/Detail/ALLY-Uterine-Positioning-System>>, 2 pgs.
 “U.S. Appl. No. 15/560,894, Preliminary Amendment dated Sep. 22, 2017”, 7 pgs.
 “U.S. Appl. No. 15/560,894, Supplemental Preliminary Amendment dated Sep. 29, 2017”, 7 pgs.
 “ASSISTO Arm System”, Geomed GMBH, [Online]. [Accessed Oct. 16, 2017]. Retrieved from the Internet: <URL: <http://www.geomed.de/index.php?id=65&L=1>>, 1 pg.
 “Atlas™ Flex Arm System”, Axxess Surgical, [Online]. [Accessed Oct. 16, 2017]. Retrieved from the Internet: <URL: <http://www.axcesssurgical.com/axcess-surgical-innovations-products/atlas-flex-arm-system/>>, 5 pgs.
 “Atlas™ Rigid Arm System”, Axxess Surgical, [Online]. [Accessed Oct. 16, 2017]. Retrieved from the Internet: <URL: <http://www.axcesssurgical.com/axcess-surgical-innovations-products/atlas-rigid-arm-system/>>, 6 pgs.
 “Bookler® StrongArm™ Holder”, Mediflex, [Online]. [Accessed Nov. 2, 2017]. Retrieved from the Internet: <URL: <http://www.mediflex.com/product/bookler-strongarm-holder-and-positioner-set-12-30cm-post/>>, (2015), 4 pgs.
 “EndoArm”, Olympus, [Online]. [Accessed Nov. 2, 2017]. Retrieved from the Internet: <URL: <https://www.olympus.co.jp/jp/news/2003b/nr030925endoj.html>>, (Sep. 25, 2003), 4 pgs.
 “EndoCrane”, Karl Storz—LEROY Retractors for Laparoscopic Colorectal Surgery, [Online]. [Accessed Oct. 16, 2017]. Retrieved from the Internet: <URL: https://www.karlstorz.com/cps/rde/xbcr/karlstorz_assets/ASSETS/2193800.pdf>, 16 pgs.
 “Genzyme Remote Surgical Retractor Arm Hands Free Pneumatic System”, Renix International/Alibaba.com Copyright 1999-2017, [Online]. [Accessed Nov. 2, 2017]. Retrieved from the Internet:

(56)

References Cited

OTHER PUBLICATIONS

<URL: http://renix.trustpass.alibaba.com/product/50001078652-219532304/Genzyme_Remote_Surgical_Retractor_Arm_Hands_Free_Pneumatic_System.html>, 2 pgs.

“Helping Hand”, Fraunhofer IPA—The helping hand in the operation room Research News, [Online]. [Accessed Oct. 16, 2017]. Retrieved from the Internet: <URL: <https://www.fraunhofer.de/en/press/research-news/2015/november/helping-hand-in-the-operation-room.html>>, (Nov. 2015), 2 pgs.

“International Application Serial No. PCT/US2016/021076, International Preliminary Report on Patentability dated Oct. 12, 2017”, 11 pgs.

“International Application Serial No. PCT/US2016/021076, International Search Report dated Aug. 11, 2016”, 4 pgs.

“International Application Serial No. PCT/US2016/021076, Invitation to Pay Add'l Fees and Partial Search Report dated May 25, 2016”, 2 pgs.

“International Application Serial No. PCT/US2016/021076, Written Opinion dated Aug. 11, 2016”, 8 pgs.

“IronIntern”, Automated Medical, [Online]. [Accessed Oct. 16, 2017]. Retrieved from the Internet: <URL: <http://ironintern.com/iron-intern%E2%84%A2>>, 1 pg.

“Jarit Endoscope Holder”, Integra, [Online]. [Accessed Oct. 16, 2017]. Retrieved from: <URL: <https://www.integralife.com/endoscope-instrument-holder-set/product/surgical-instruments-hospitals-surgery-centers-tissue-banks-jarit-laparoscopic-endoscopes-endoscope-instrument-holder-set>>, 18 pgs.

“M-Trac”, Aesculap / B Braun, [Online]. [Accessed Oct. 16, 2017]. Retrieved from the Internet: <URL: <https://www.bbraun.com/en/products/b/m-trac.html>>, 2 pgs.

“Martin’s Arm”, Hayden Medical (& others), [Online]. [Accessed Oct. 16, 2017]. Retrieved from the Internet: <URL: <http://haydenmedical.com/surgical-retractors-martins-arm-retractors/>>, 2 pgs.

“Mechanical Arm—Mod. 8470”, Ansabere Surgical, [Online]. [Accessed Oct. 16, 2017]. Retrieved from the Internet: <URL: <http://www.ansaberesurgical.com/en/productos/brazos-mecanicos/brazo-mecanico-mod-8470/>>, 5 pgs.

“Phantom ML”, TeDan Surgical Innovations, [Online]. [Accessed Nov. 14, 2017]. Retrieved from the Internet: <URL: <http://www.tedansurgical.com/spine/articulating-arms/>>, 2 pgs.

“Point Setter”, Mitaka Kohki Co., Ltd. Operating / User’s Manual Model: PSMS2, (Feb. 14, 2010), 28 pgs.

“PositionOR”, Surgical Concept Designs, [Online]. [Accessed Nov. 14, 2017]. Retrieved from the Internet: <URL: <http://surgical-concepts.com/products/PositionOR/>>, 1 pg.

“Positioning Arm”, Civco—Laparostat™ Kit, [Online]. [Accessed Oct. 16, 2017]. Retrieved from the Internet: <URL: <http://www.civco.com/mmi/resources/ifu/043687.pdf>>, 16 pgs.

“SaphLITE | RadLITE”, Teleflex Medical, [Online]. [Accessed Nov. 14, 2017]. Retrieved from the Internet: <URL: https://www.teleflex.com/en/usa/prod_saphlite-radlite.php>, 1 pg.

“Saphlite/Saphlift”, Genzyme Surgical Products (Jan. 7, 1999), [Online]. [Accessed Oct. 16, 2017]. Retrieved from the Internet: <URL: https://www.accessdata.fda.gov/cdrh_docs/pdf/K990062.pdf>, 5 pgs.

“Speed-Tract”, Integra—Table Mounted Speed—Tract Retractor System, [Online]. [Accessed Oct. 16, 2017]. Retrieved from the

Internet: <URL: <http://occ.integralife.com/products%2Fpdfs%2Fintegra%20table%20mounted%20speed-tract%20retractor%20system%20brochure.pdf>>, 6 pgs.

“Spider2 Limb Positioner”, Smith & Nephew, [Online]. [Accessed Nov. 14, 2017]. Retrieved from the Internet: <URL: <http://www.smith-nephew.com/new-zealand/advanced-surgical-devices/key-products/sports-medicine/spider2-limb-positioner-for-shoulder-hip-knee-/>>, 2 pgs.

“Spine Endoscope & Endoscope Holder”, Maxer, [Online]. [Accessed Nov. 2, 2017]. Retrieved from the Internet: <URL: http://www.maxerendoscopy.com/index.php?option=com_content&view=article&id=190:spine-endoscope-endoscope-holder&catid=81:spine-endoscopy&Itemid=858>, (2013).

“SurgiAssist Camera Holder”, SurgiToolsMIS, [Online]. [Accessed Nov. 14, 2017]. Retrieved from the Internet: <URL: <https://www.surgitools.com/surgiassist-camera-holder.html>>, 4 pgs.

“Synaptive BrightMatter Drive Robotic Surgical Video Arm System”, Synaptive, [Online]. [Accessed Nov. 14, 2017]. Retrieved from the Internet: <URL: <https://www.medgadget.com/2016/05/synaptive-brightmatter-drive-robotic-surgical-videoarm-system.html>>, 3 pgs.

“TEE Transducer Holder”, Civco, [Online]. [Accessed Oct. 16, 2017]. Retrieved from the Internet: <URL: http://www.civco.com/mmi/resources/product-support/TEE-Holder-Brochure_2008P-2339-Rev-2_low-res-819rv5.pdf>, 8 pgs.

“The Freehand System”, Freehand—V1.2, [Online]. [Accessed Oct. 16, 2017]. Retrieved from the Internet: <URL: <http://freehandsurgeon.com/Products/Detail?id=2>>, 3 pgs.

“TiREX® Retractor System”, Orion Surgical, [Online]. [Accessed Nov. 2, 2017]. Retrieved from the Internet: <URL: <http://www.orion-surgical.com/english/tirex-retractor-system/components-of-the-tirex.html>>, (2017), 2 pgs.

“TRIMANO 3D Support Arm”, Maquet, [Online]. [Accessed Oct. 16, 2017]. Retrieved from the Internet: <URL: <https://www.maquet.com/int/products/trimano-3d-support-arm/>>, 3 pgs.

“UniARM Surgical Support System”, Mitaka Kohki Co., Ltd. Operating / User Manual Version 1.1, [Online]. [Accessed Nov. 2, 2017]. Retrieved from the Internet: <URL: <http://mitakausa.com/uniarml/>>, (Mar. 20, 2009), 19 pgs.

“Unitrac® Pneumatic Holding Arm”, Aesculap / B Braun, [Online]. [Accessed Oct. 16, 2017]. Retrieved from the Internet: <URL: <https://www.bbraun.com/en/products/b/unitrac-pneumaticholdingarm.html>>, 3 pgs.

“Vertek Articulating Arm”, Medtronic—Copyright 2013, [Online]. [Accessed Nov. 2, 2017]. Retrieved from the Internet: <URL: <http://global.medtronic.com/xg-en/healthcare-professionals/products/neurological/surgical-navigation-imaging/neurosurgery-imaging-surgical-navigation/surgical-procedures.html>>, 2 pgs.

“VIKY”, Endocontrol Medical, [Online]. [Accessed 2014]. Retrieved from the Internet: <URL: <http://www.endocontrol-medical.com/en/viky-en/>>, 5 pgs.

“Wingman Scope Holder”, Stryker, [Online]. [Accessed Nov. 14, 2017]. Retrieved from the Internet: <URL: <http://www.stryker.com/cn/products/OREquipmentTelemedicine/EndoscopicSurgeryEquipment/Laparoscopy/Accessories/ScopeHolder/index.htm#>>, 3 pgs.

“U.S. Appl. No. 15/918,531, Non Final Office Action dated Sep. 26, 2019”, 12 pages.

“U.S. Appl. No. 15/919,161, Non Final Office Action dated Sep. 26, 2019”, 18 pages.

* cited by examiner

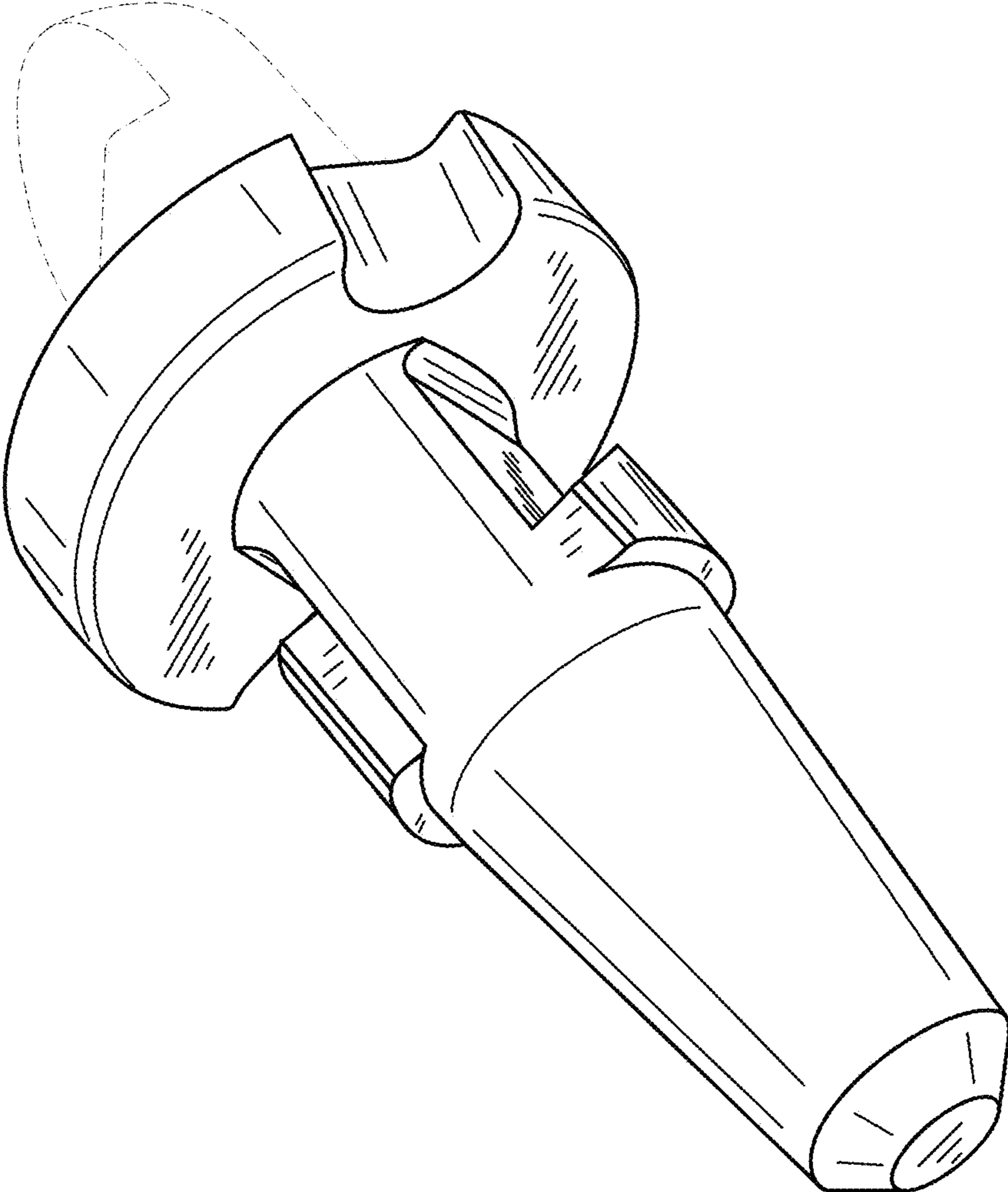

FIG. 1

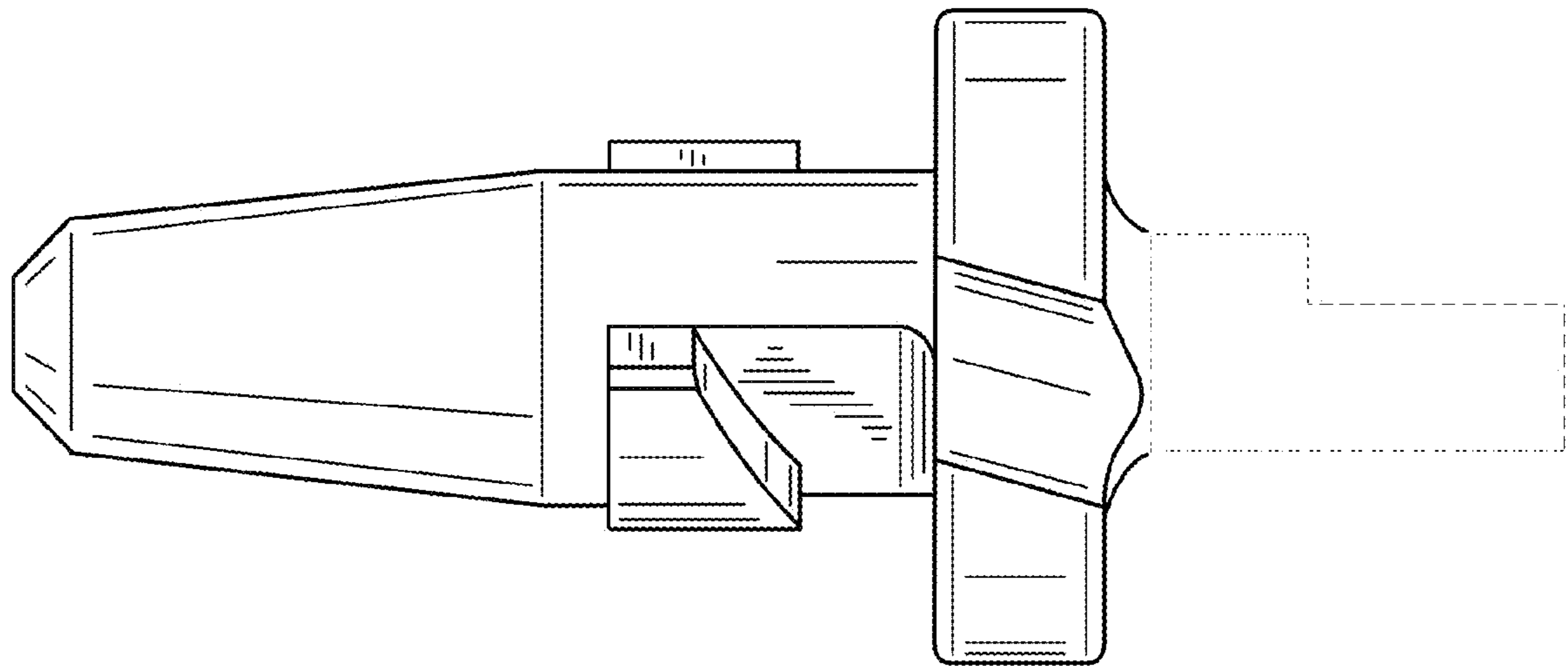

FIG. 2

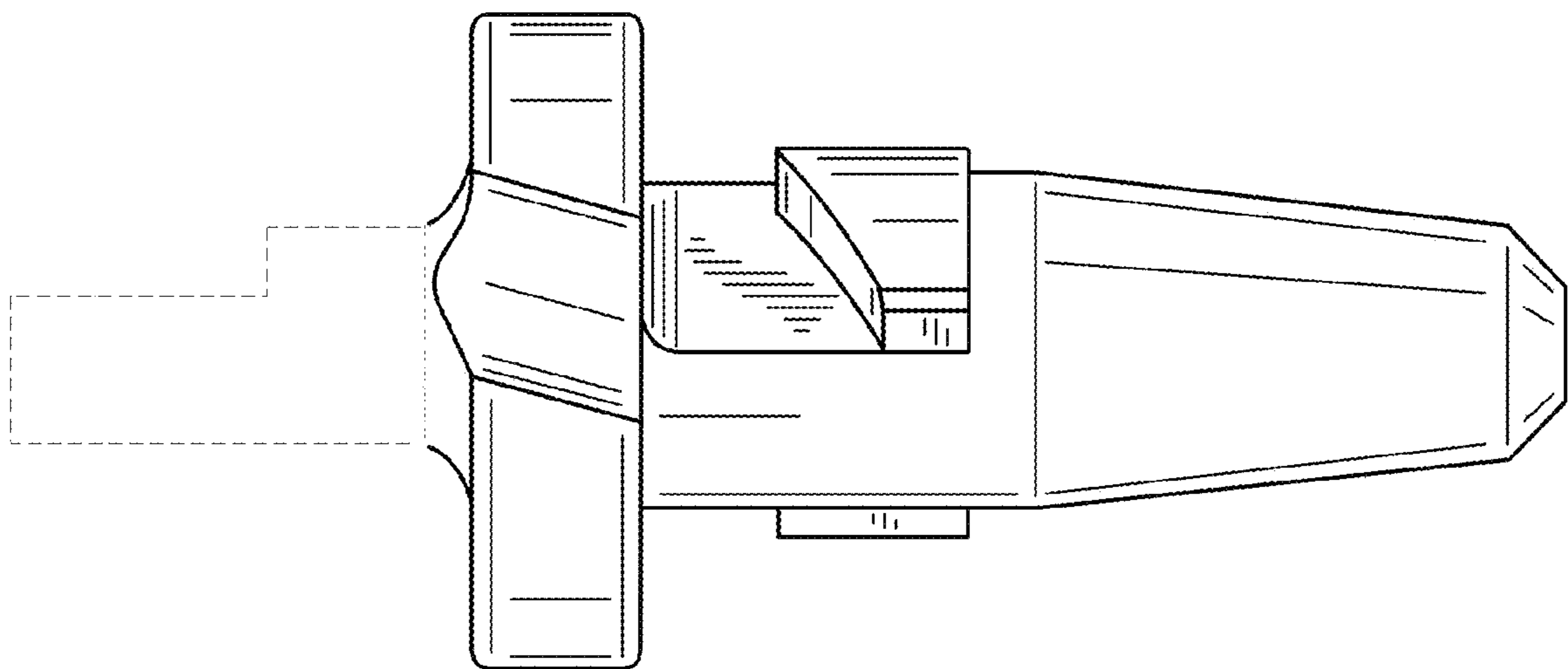

FIG. 3

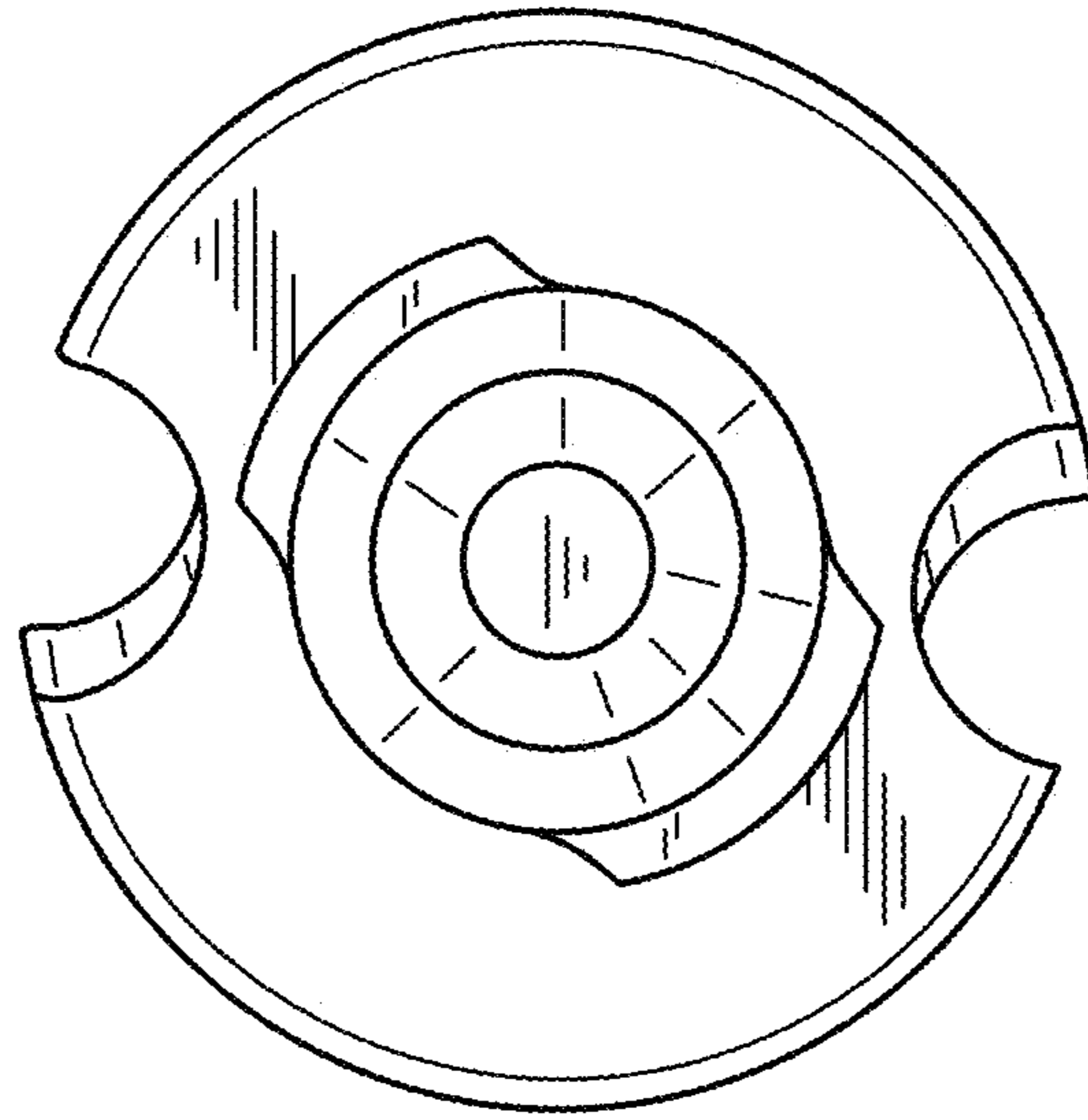

FIG. 4

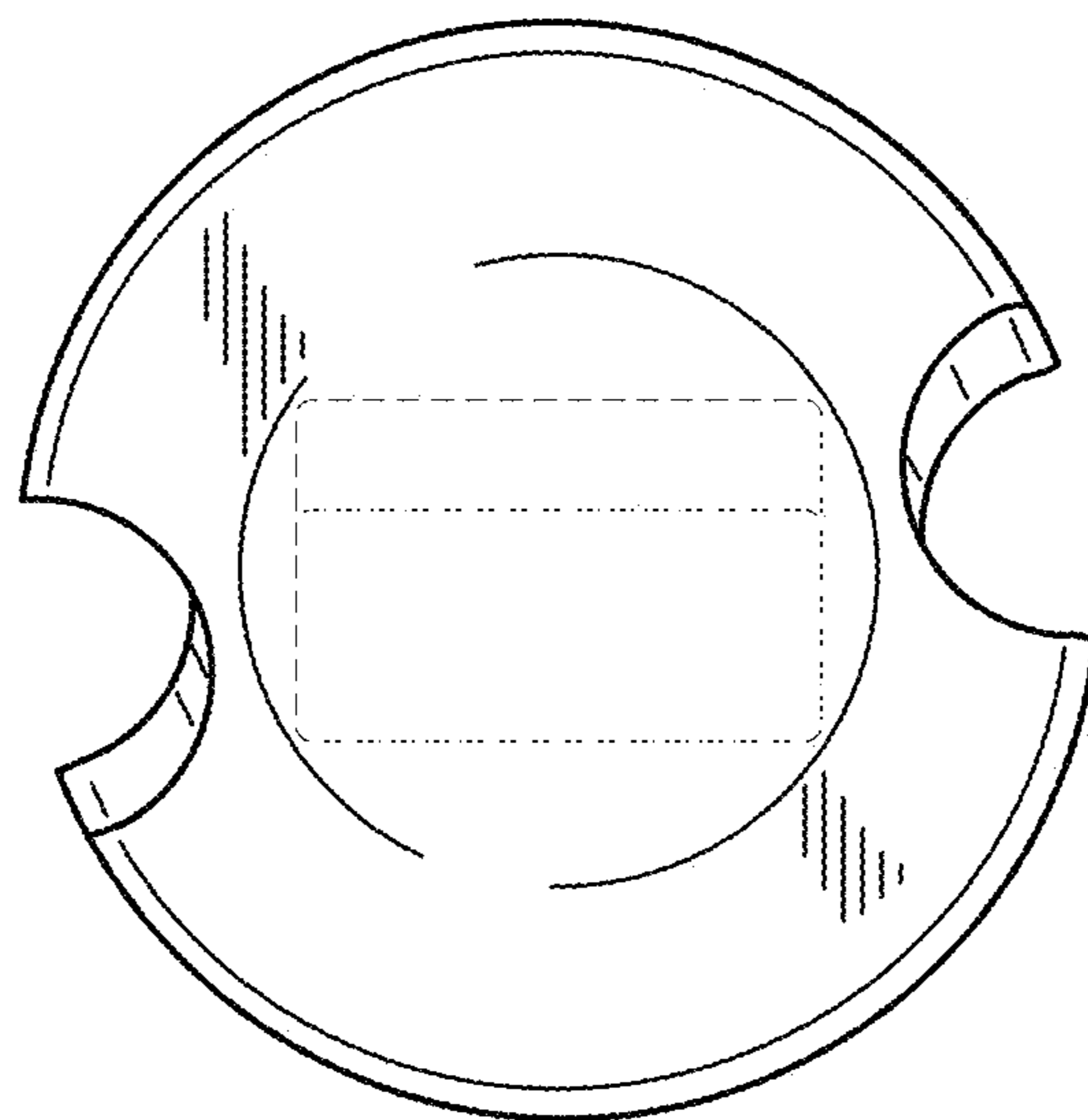

FIG. 5

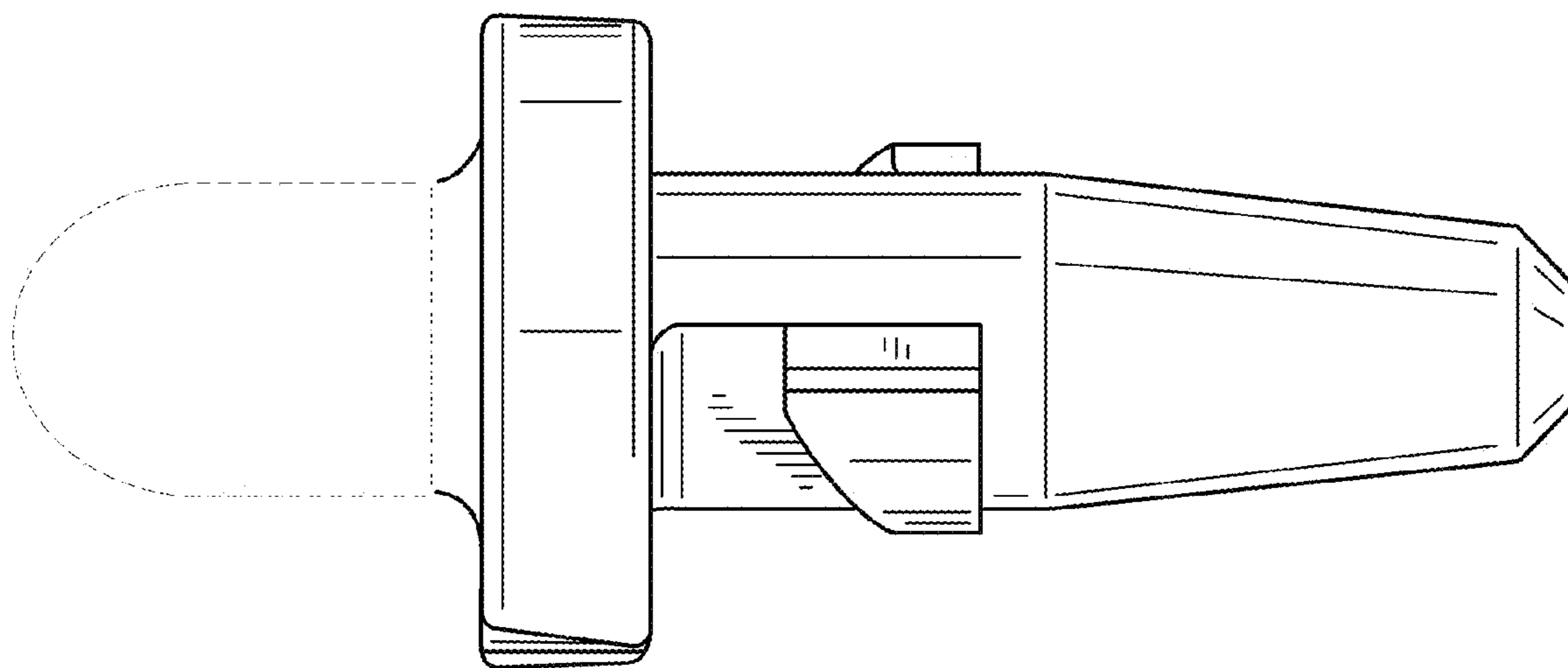

FIG. 6

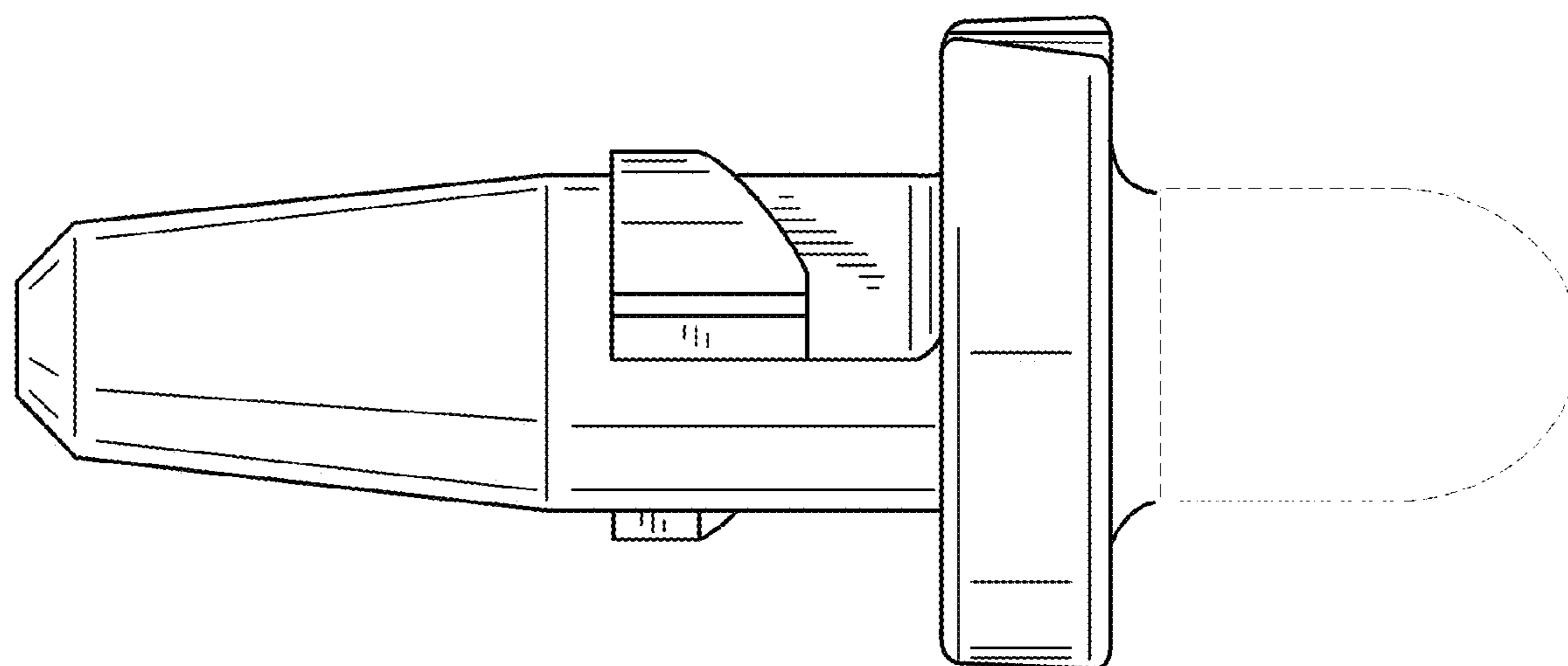

FIG. 7

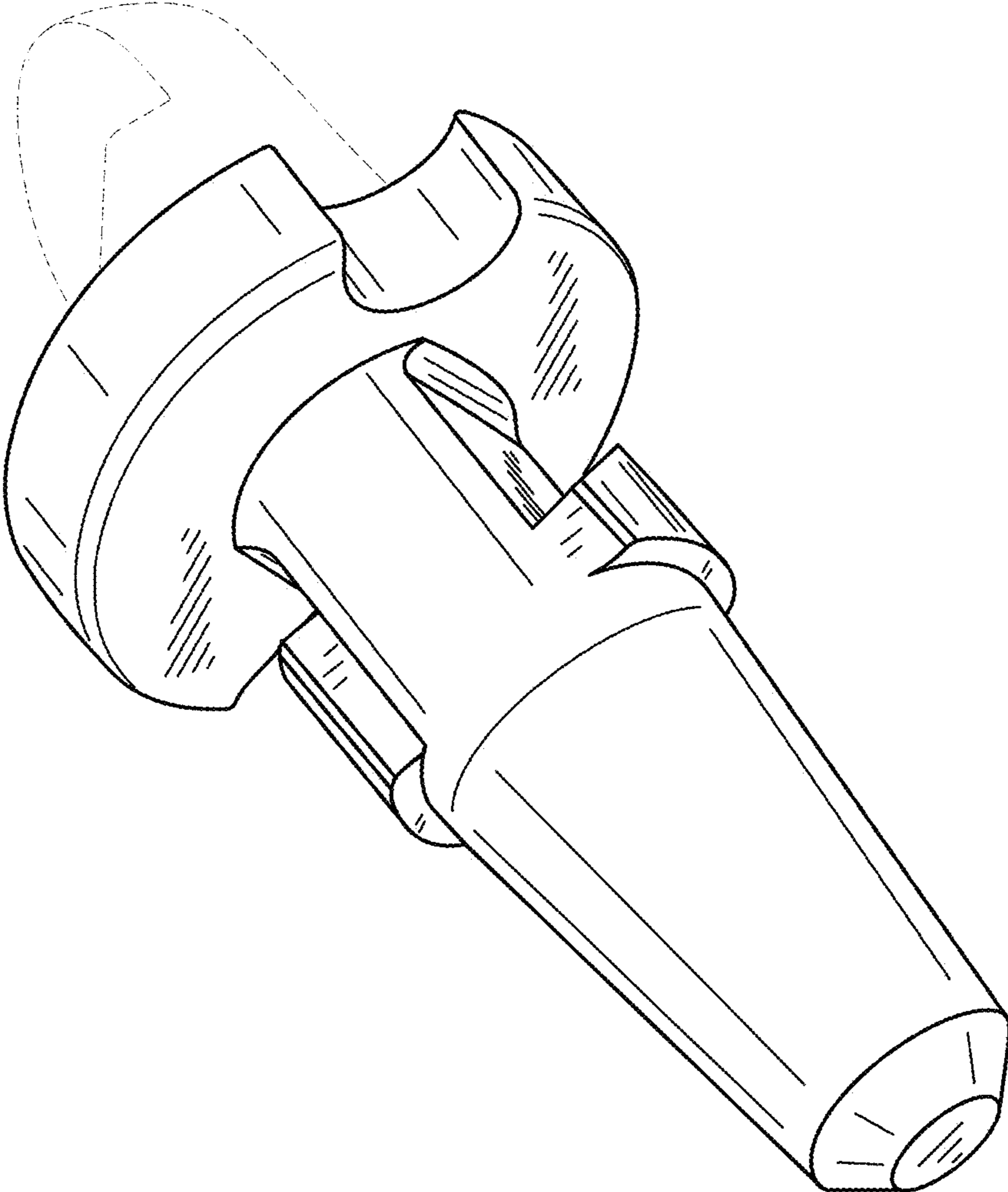

FIG. 8

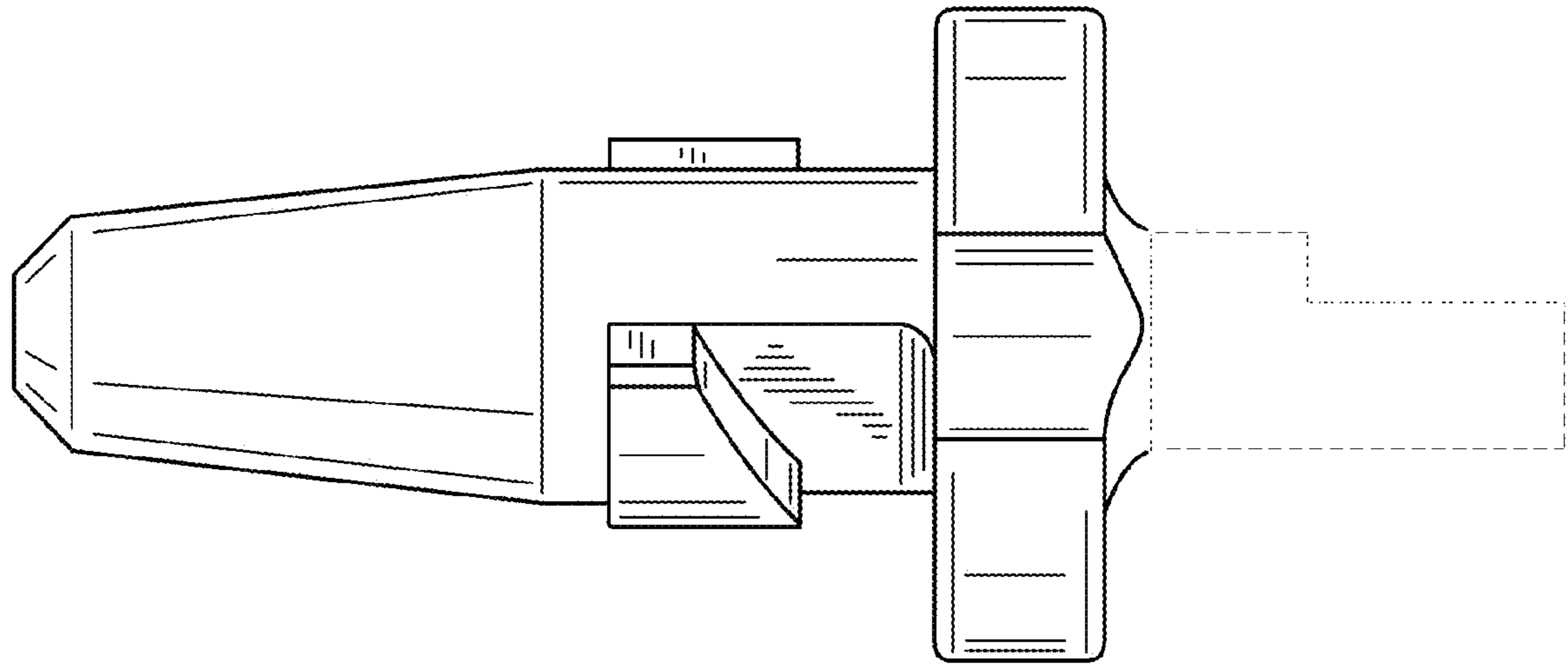

FIG. 9

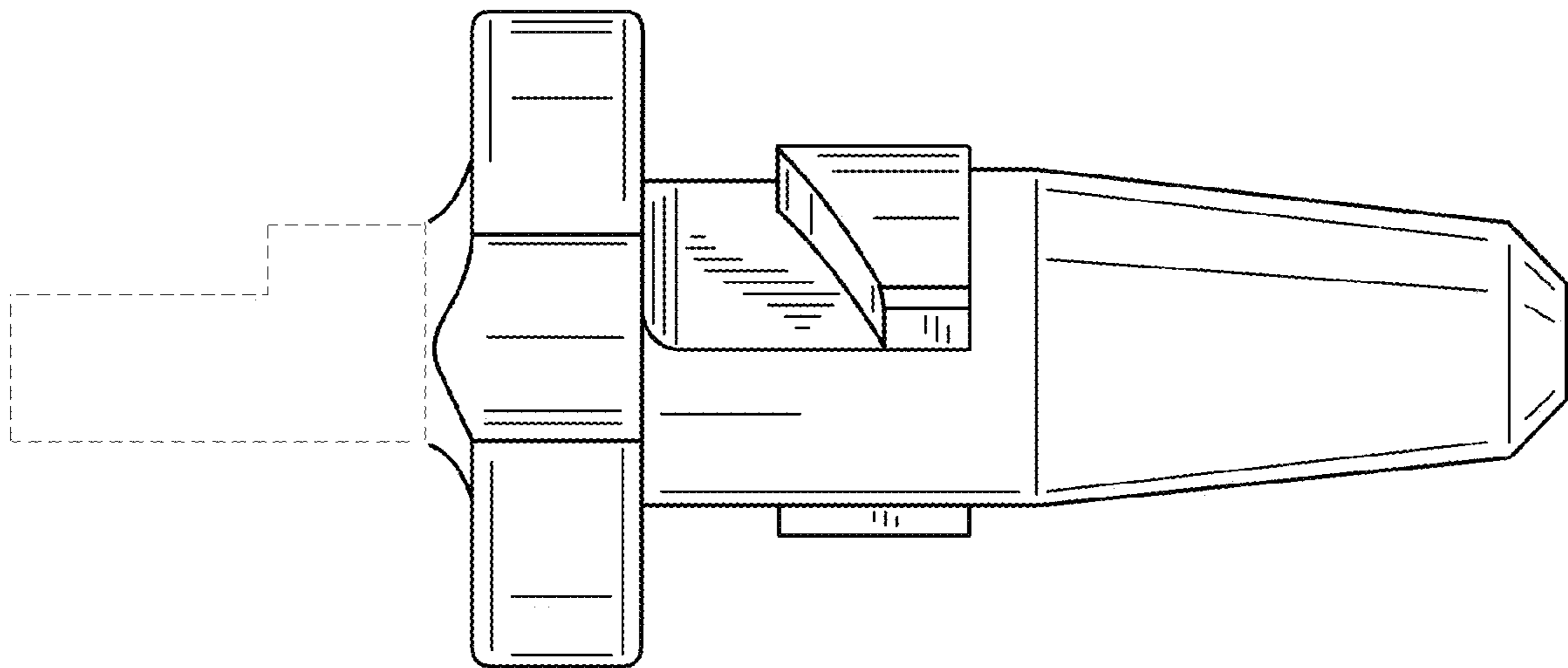

FIG. 10

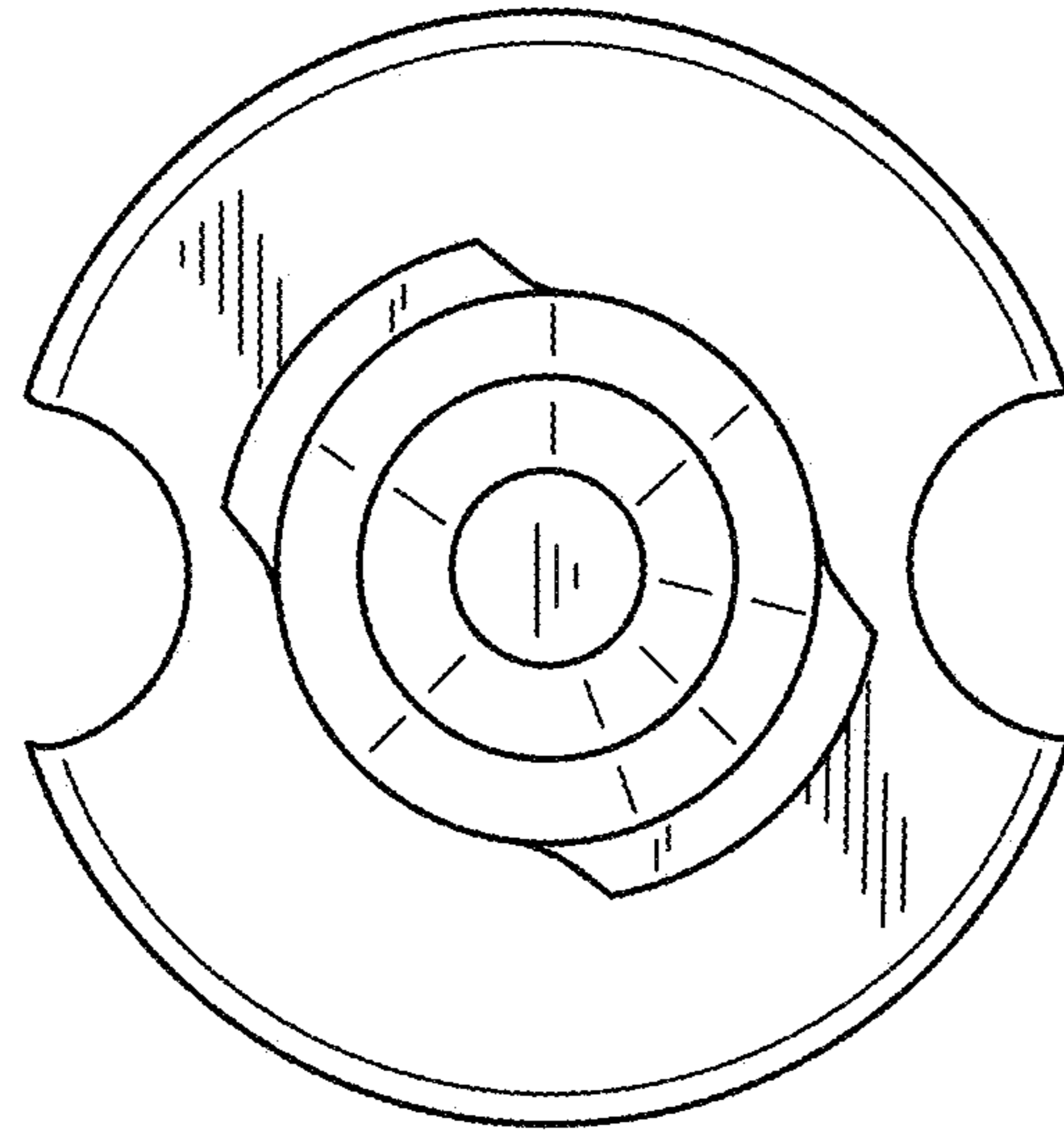

FIG. 11

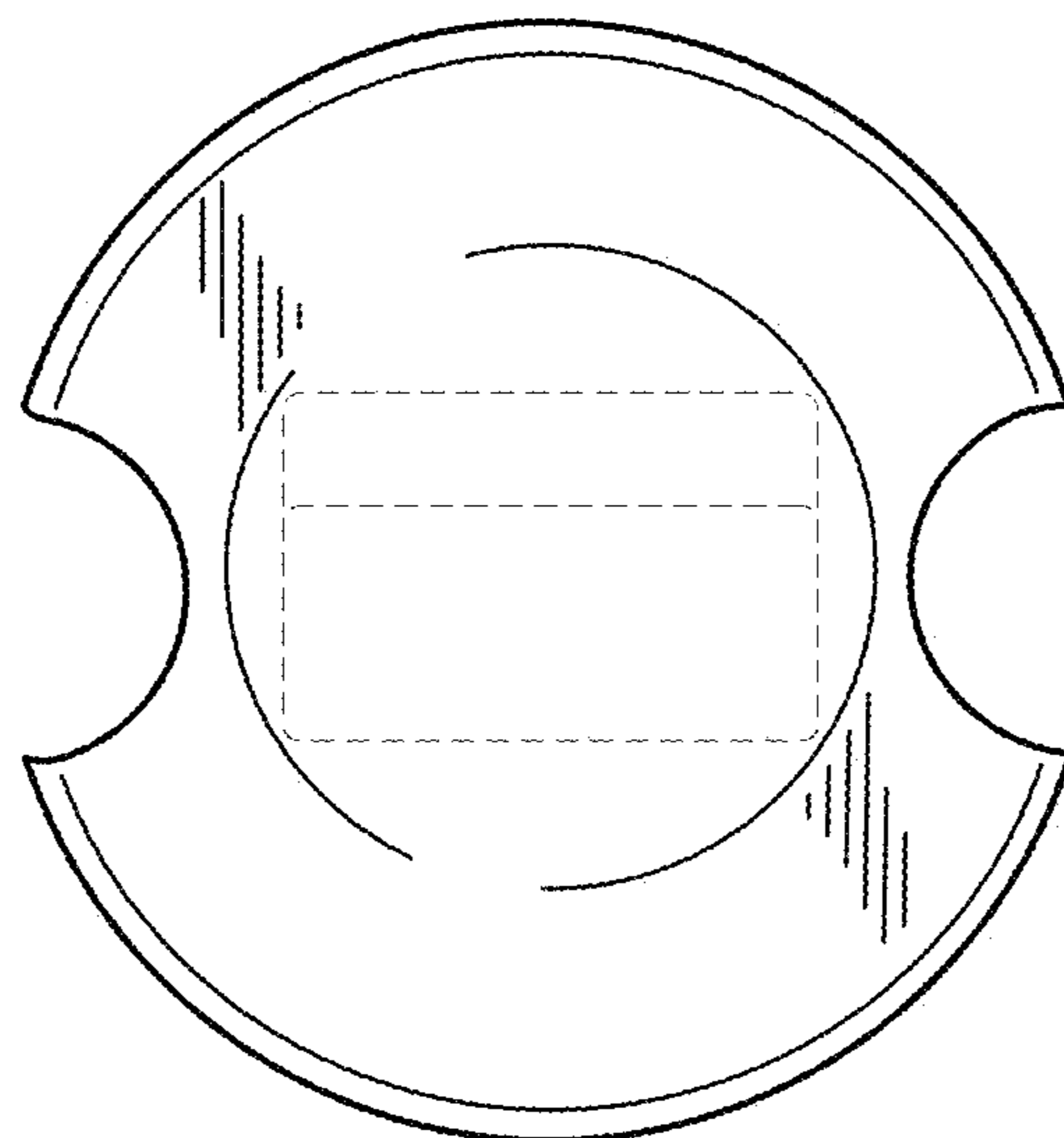

FIG. 12

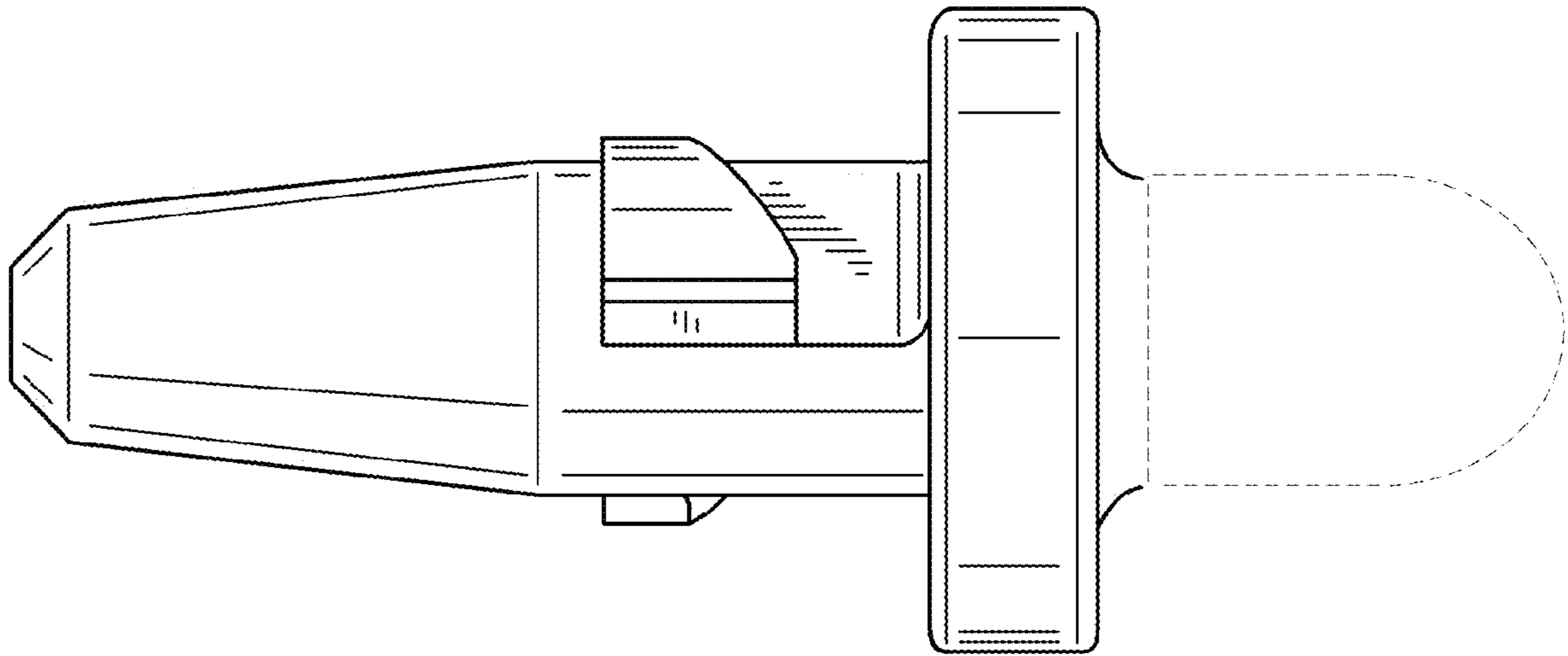

FIG. 13

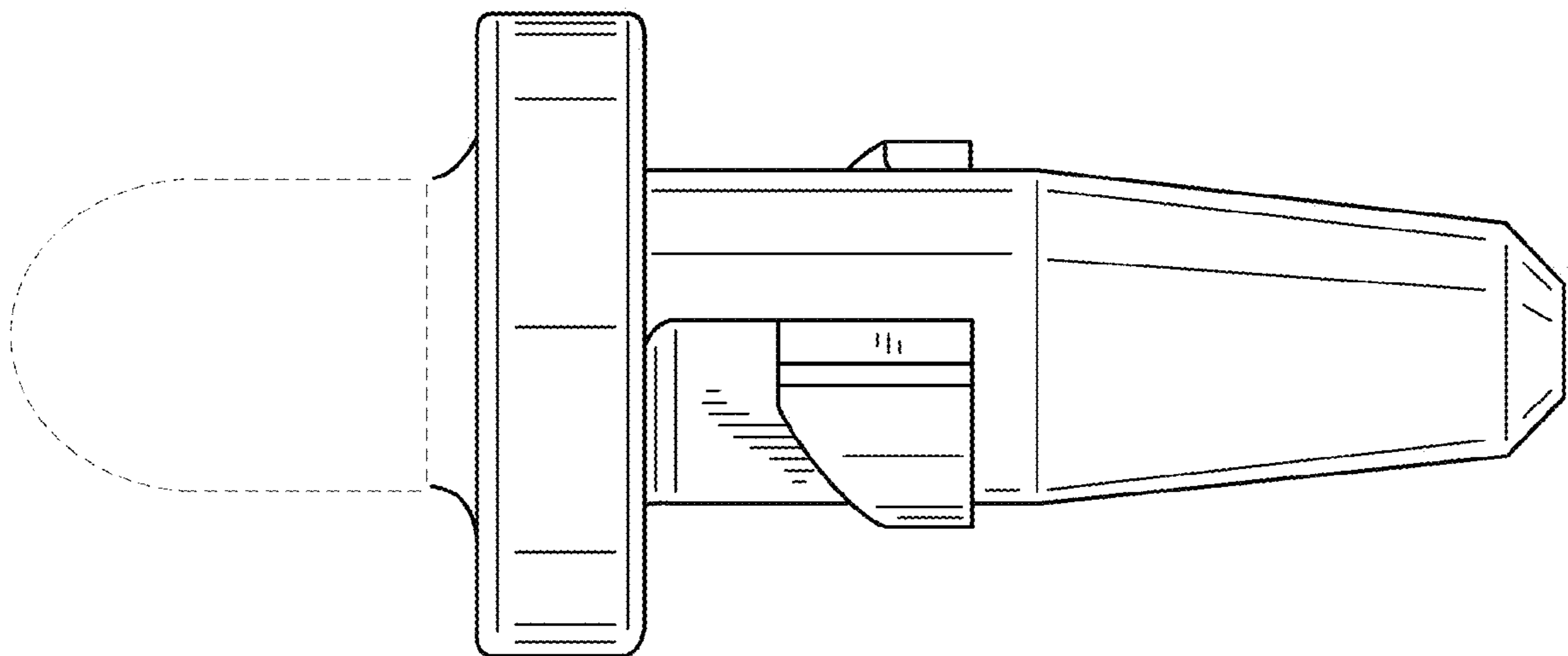

FIG. 14