

US00D878252S

(12) **United States Design Patent**  
**Carlini**

(10) **Patent No.:** **US D878,252 S**  
(45) **Date of Patent:** **\*\* Mar. 17, 2020**

- (54) **CONSTANT VELOCITY JOINT**
- (71) Applicant: **Aircraft Gear Corporation**, Loves Park, IL (US)
- (72) Inventor: **Sean M. Carlini**, Rockford, IL (US)
- (73) Assignee: **Aircraft Gear Corporation**, Loves Park, IL (US)
- (\*\*) Term: **15 Years**
- (21) Appl. No.: **29/657,034**
- (22) Filed: **Jul. 18, 2018**

**Related U.S. Application Data**

- (62) Division of application No. 29/571,078, filed on Jul. 14, 2016, now Pat. No. Des. 823,735.
- (51) **LOC (12) Cl.** ..... **12-16**
- (52) **U.S. Cl.**  
USPC ..... **D12/160**
- (58) **Field of Classification Search**  
USPC ..... D12/159-160  
CPC ..... F16C 3/02; F16D 3/30  
See application file for complete search history.

**References Cited**

**U.S. PATENT DOCUMENTS**

4,813,704 A *	3/1989	Smith	.....	B6G 3/265 280/124.109
5,794,341 A	8/1998	Carlini		
5,802,705 A	9/1998	Carlini		
5,833,026 A	11/1998	Zetterstrom et al.		
D411,668 S	6/1999	Settelmayer, Jr. et al.		
D445,120 S	7/2001	Parsons		
D462,256 S	9/2002	Jaynes		
6,752,403 B2	6/2004	Allen et al.		
6,755,429 B1	6/2004	Buchwitz		
D498,568 S	11/2004	Colman et al.		
D504,061 S	4/2005	Fisher et al.		

(Continued)

*Primary Examiner* — Michael A. Pratt  
(74) *Attorney, Agent, or Firm* — John V. Daniluck;  
Bingham Greenebaum Doll LLP

(57) **CLAIM**

The ornamental design for a constant velocity joint, as shown and described.

**DESCRIPTION**

FIG. 1 is a front, left, top perspective view looking rearward of a constant velocity joint according to one embodiment of the present invention;  
 FIG. 2 is a right, rear, top perspective view looking forward thereof;  
 FIG. 3 is a left side elevational view thereof, the right side elevational, top plan view and bottom plan view being identical;  
 FIG. 4 is a front elevational end view thereof;  
 FIG. 5 is a rear elevational end view thereof;  
 FIG. 6 is a perspective view of a portion thereof shown installed in a vehicle.  
 FIG. 7 is a front, left, top perspective view looking rearward of a constant velocity joint according to another embodiment of the present invention, and with a cross hatch pattern shown on a portion of the device indicating that portion of the device to be colored orange;  
 FIG. 8 is a right, rear, top perspective view looking forward thereof;  
 FIG. 9 is a left side elevational view thereof, the right side elevational, top plan view and bottom plan view being identical;  
 FIG. 10 is a front elevational end view thereof;  
 FIG. 11 is a rear elevational end view thereof; and,  
 FIG. 12 is a perspective view of a portion thereof shown installed in a vehicle.  
 The broken line showing of the constant velocity joint is included for the purpose of illustrating environment and forms no part of the claimed design.

**1 Claim, 6 Drawing Sheets**

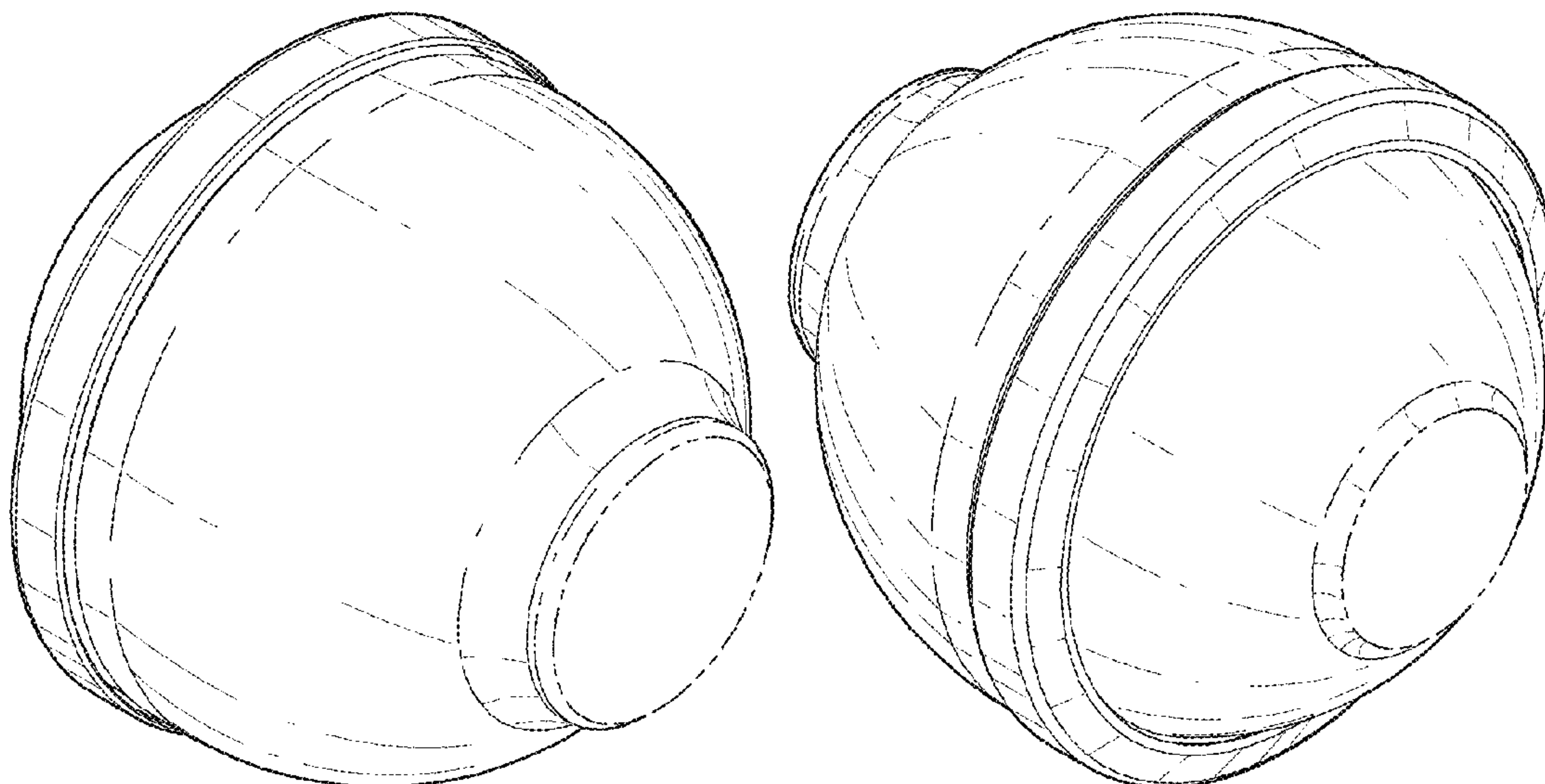

(56)

**References Cited**

U.S. PATENT DOCUMENTS

7,025,684	B2 *	4/2006	Frana .....	F16D 3/224 464/145
7,143,861	B2	12/2006	Chu	
D607,912	S	1/2010	Medici	
7,819,411	B2	10/2010	Eshelman et al.	
D664,032	S	7/2012	Su	
8,465,035	B2	6/2013	Gander	
8,517,140	B2	8/2013	West et al.	
D698,637	S	2/2014	Su	
9,221,496	B2	12/2015	Barr et al.	
9,267,596	B2	2/2016	Trost	
9,556,915	B2	1/2017	Hirukawa et al.	
9,581,206	B2	2/2017	Yamazaki et al.	
9,746,036	B2	8/2017	Tosaji et al.	
D823,735	S *	7/2018	Carlini .....	D12/160
2005/0124421	A1 *	6/2005	Park .....	F16D 3/223 464/143
2009/0173033	A1 *	7/2009	Baxter, Jr. ....	A63J 1/00 52/646
2017/0328418	A1 *	11/2017	Carlini .....	F16D 3/848

\* cited by examiner

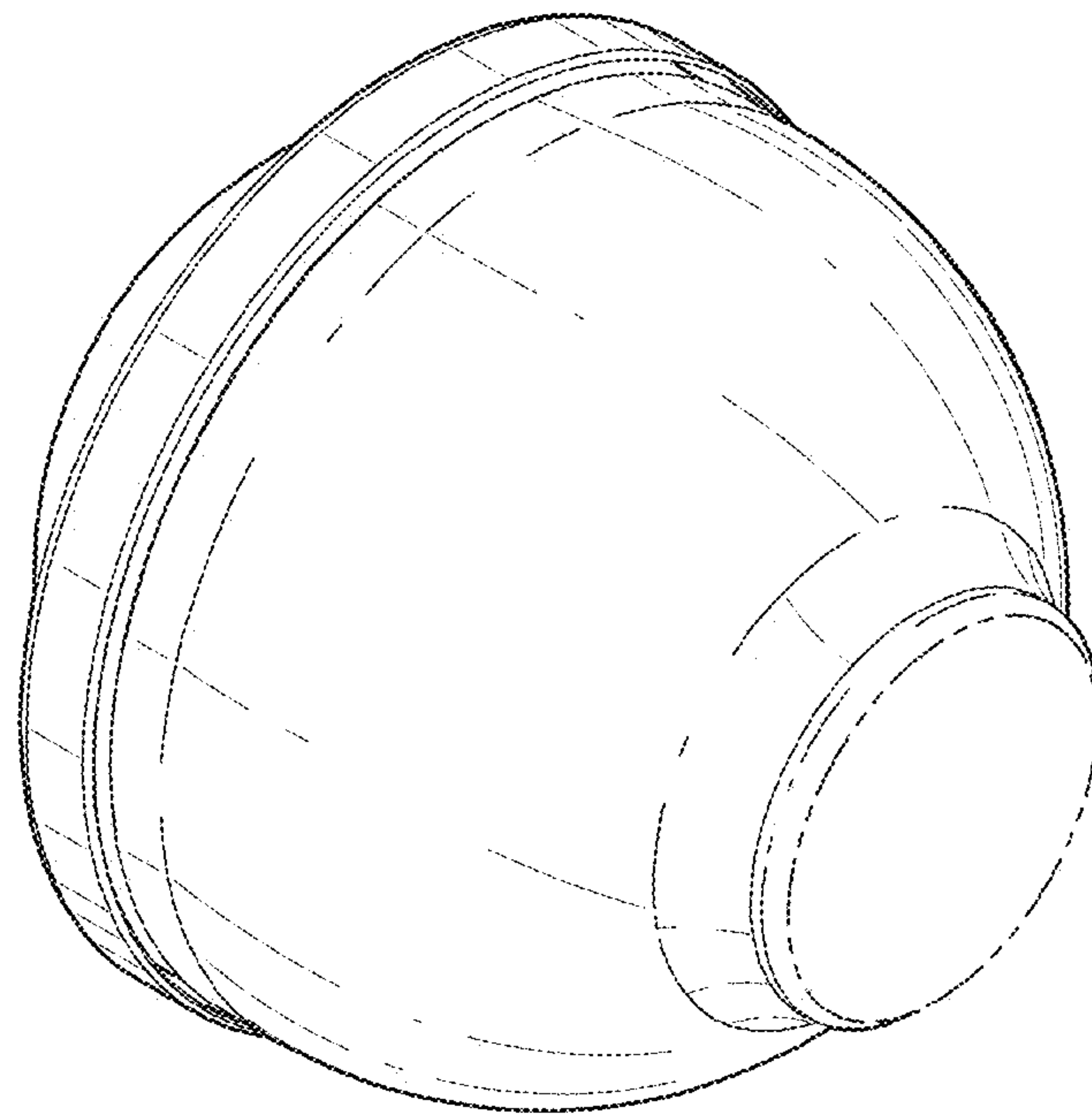

FIG. 1

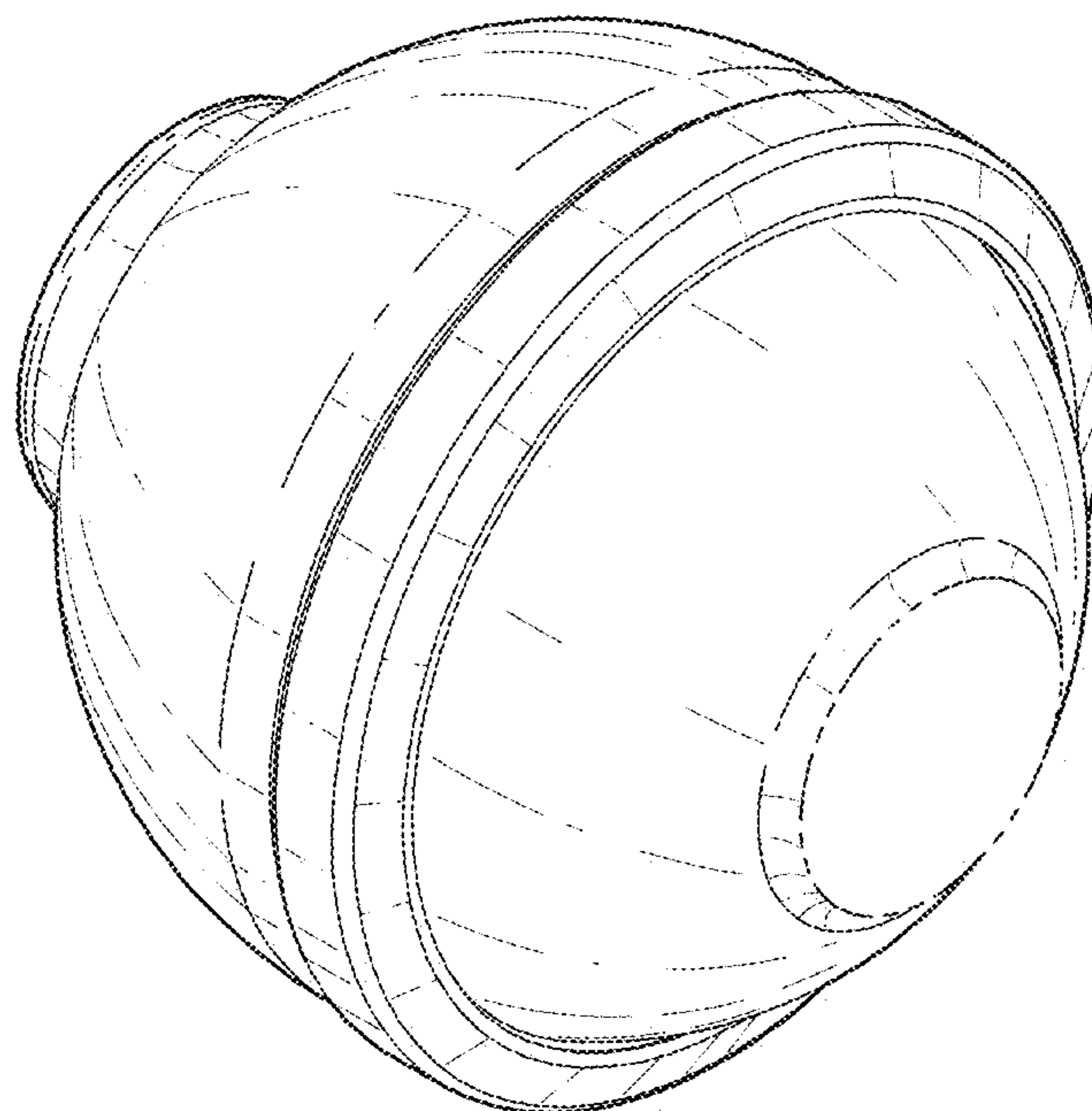

FIG. 2



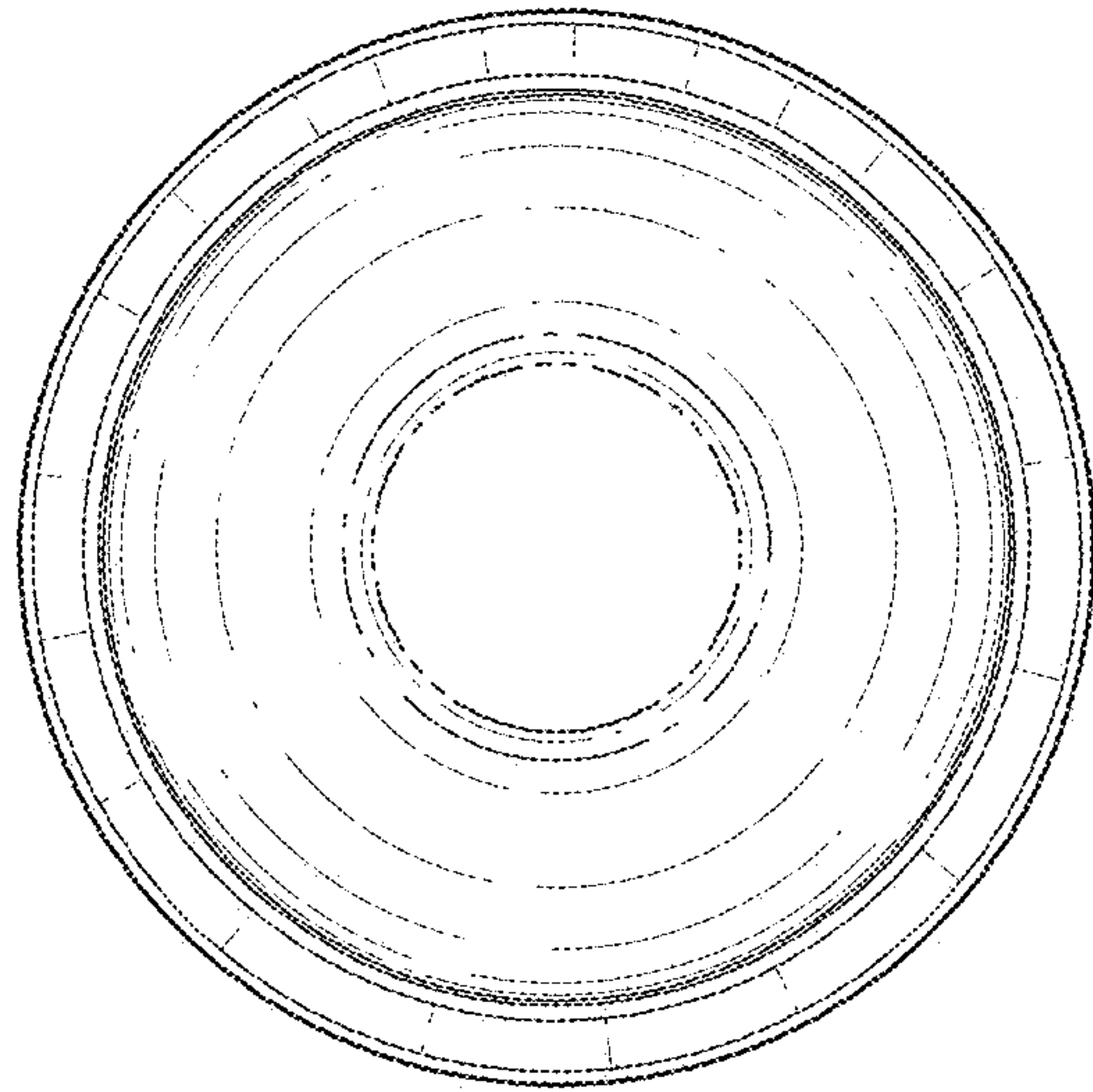

FIG. 3

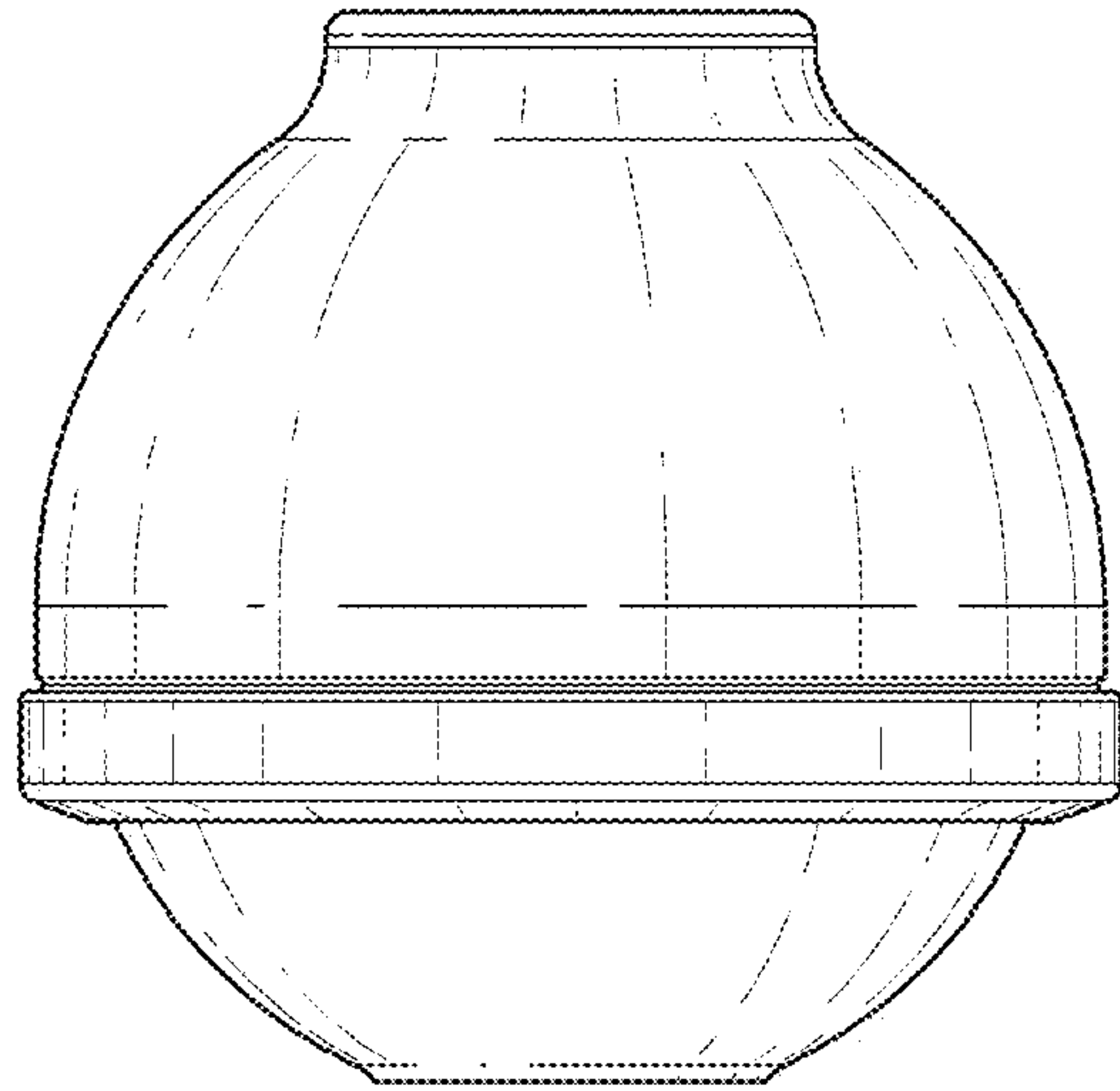

FIG. 4

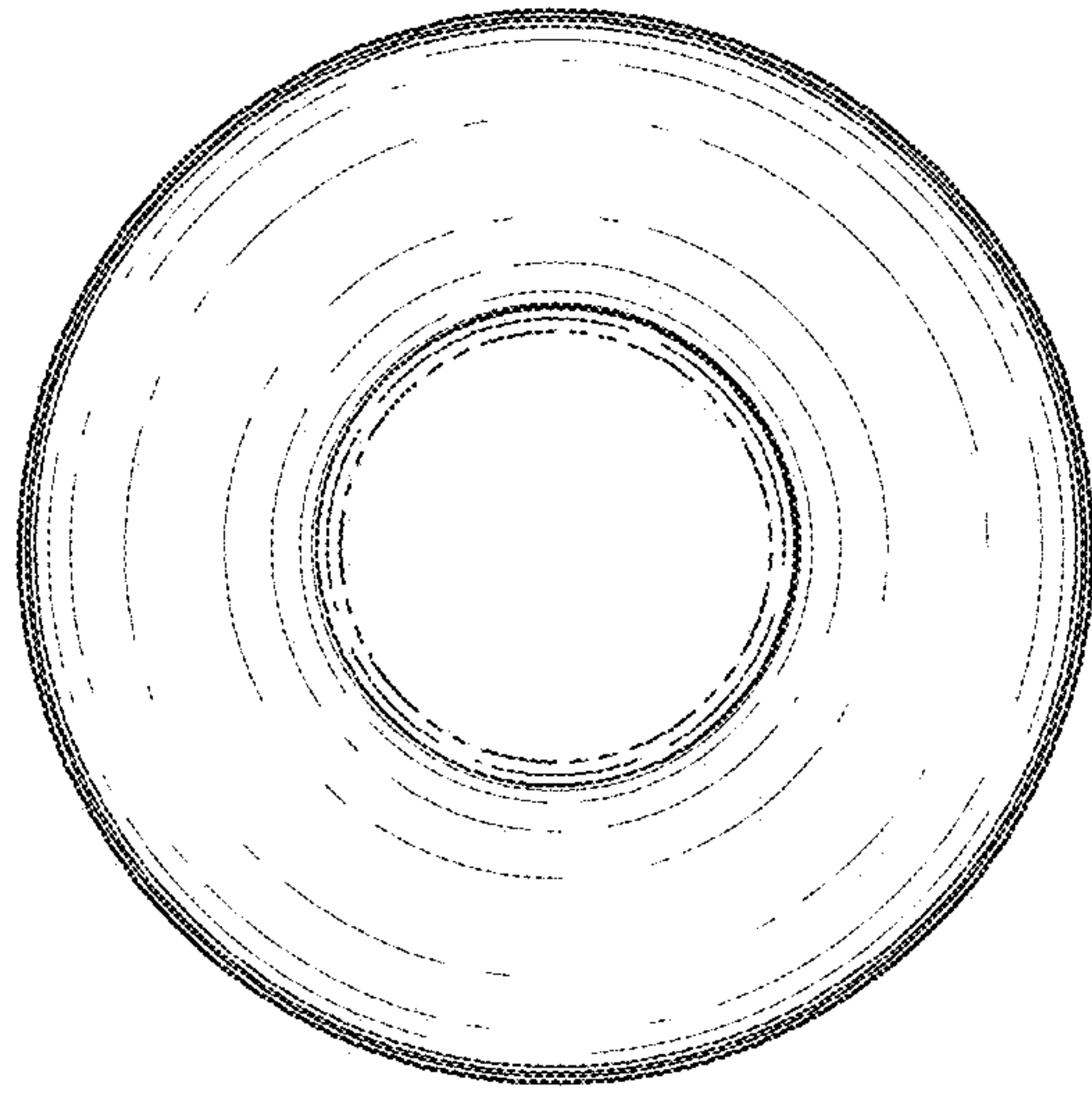

FIG. 5

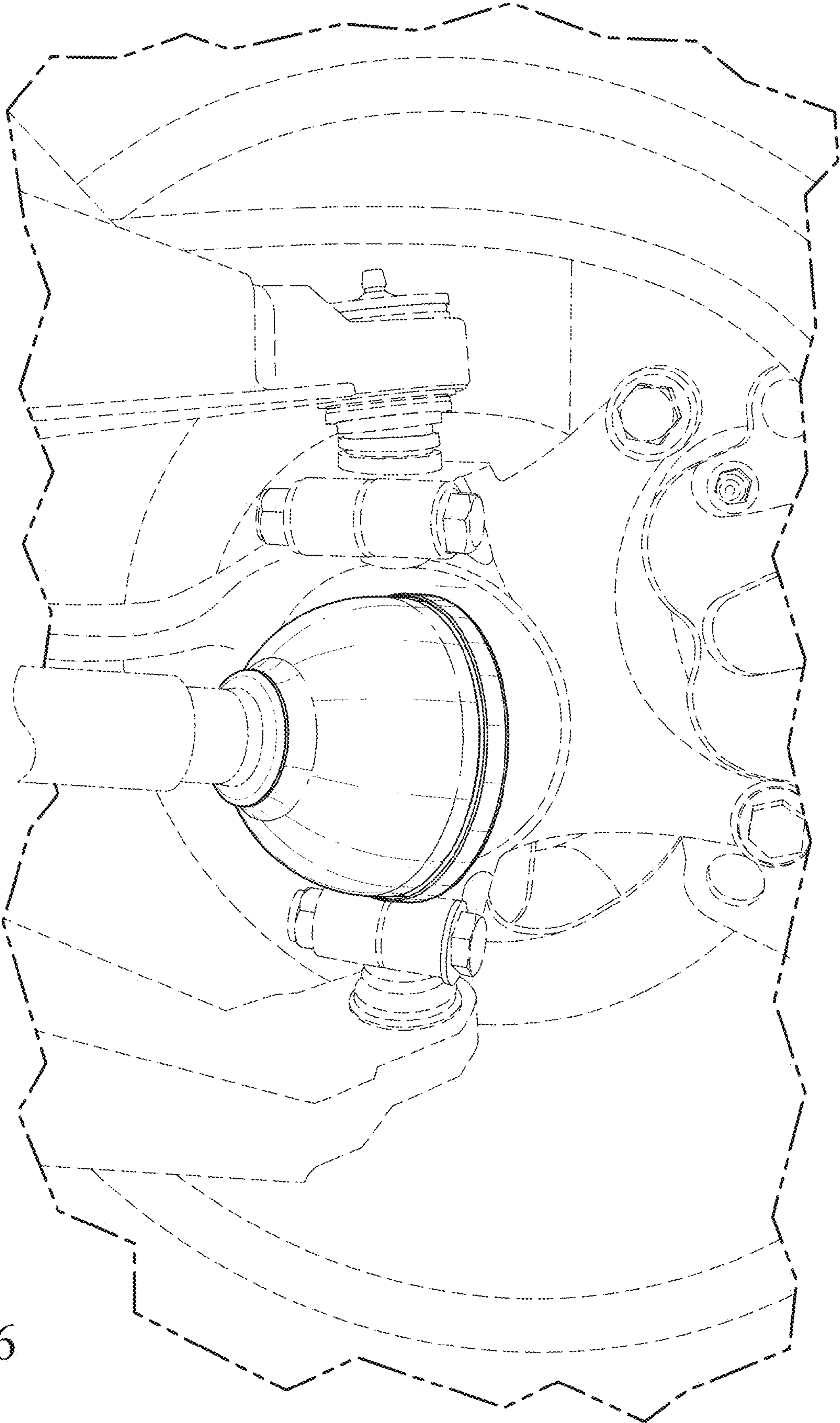

FIG. 6

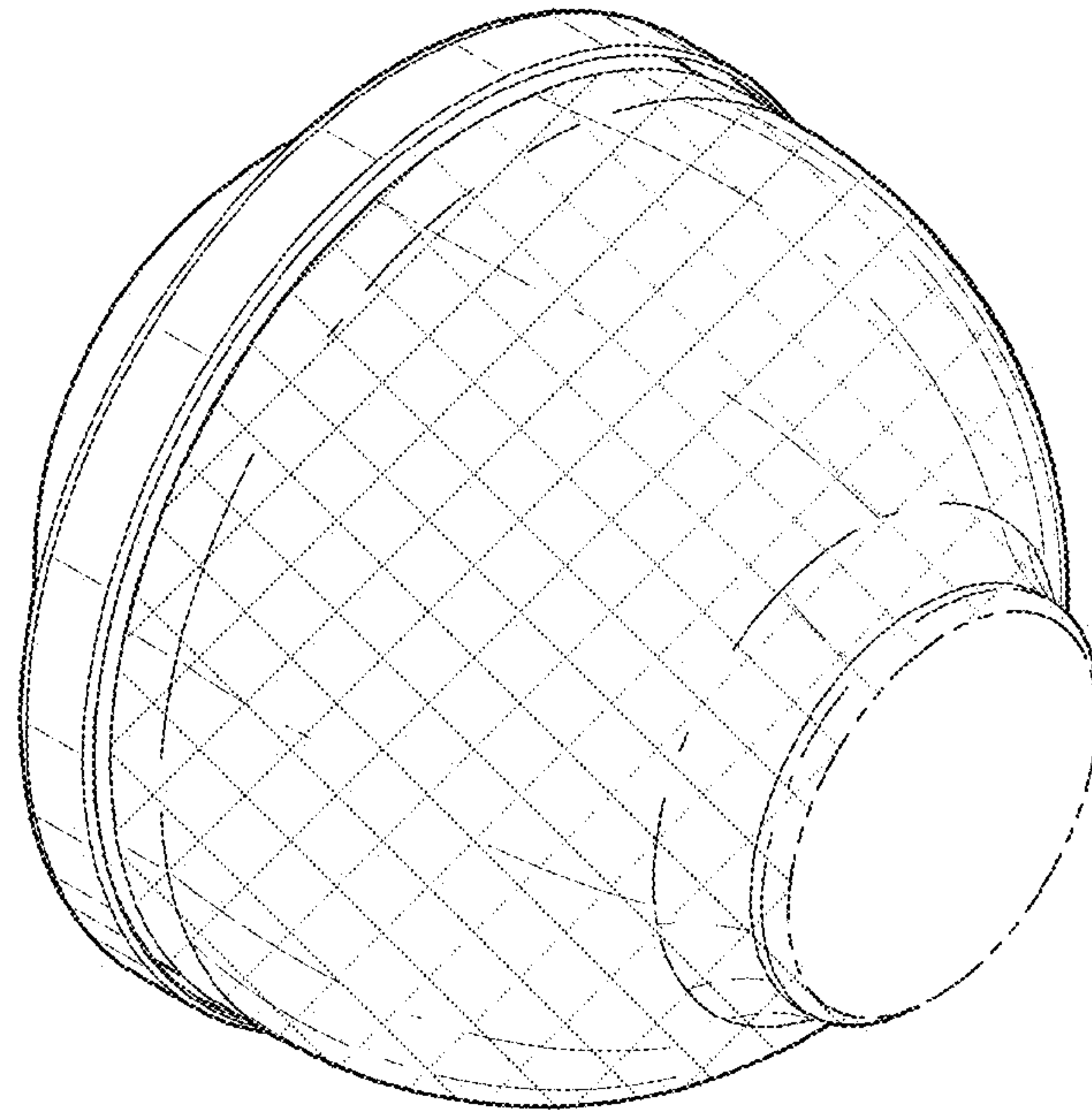

FIG. 7

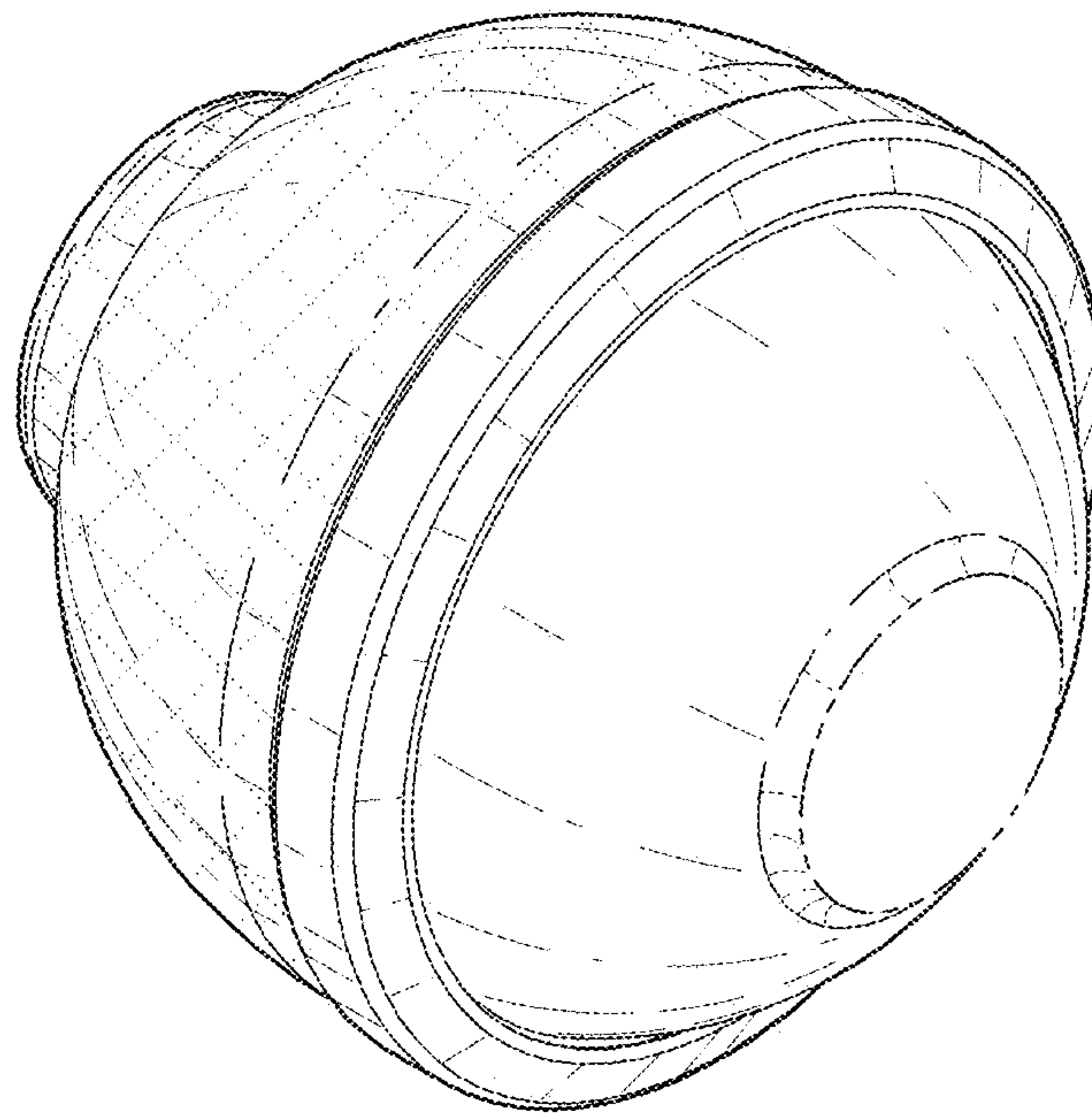

FIG. 8



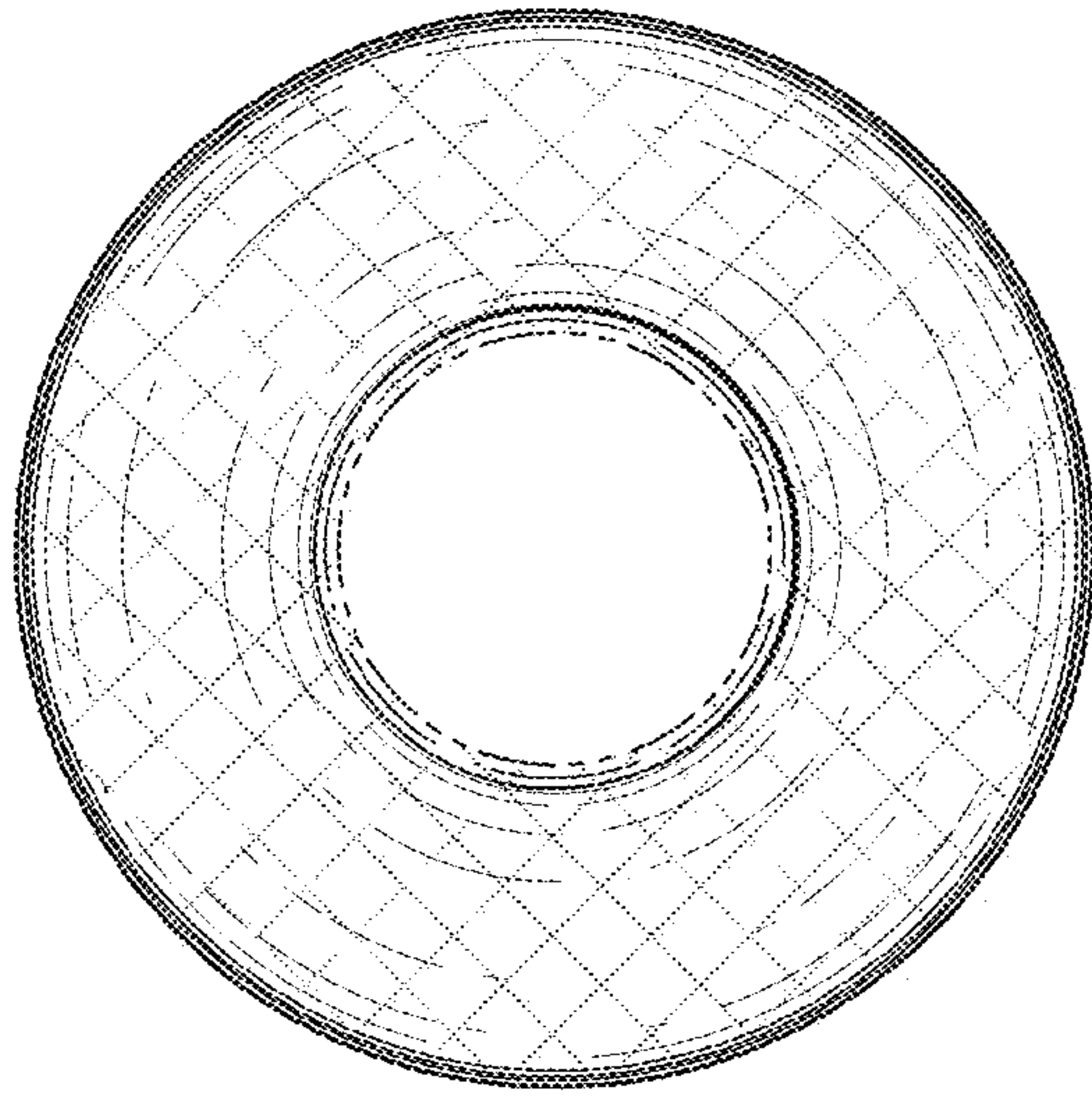

FIG. 11

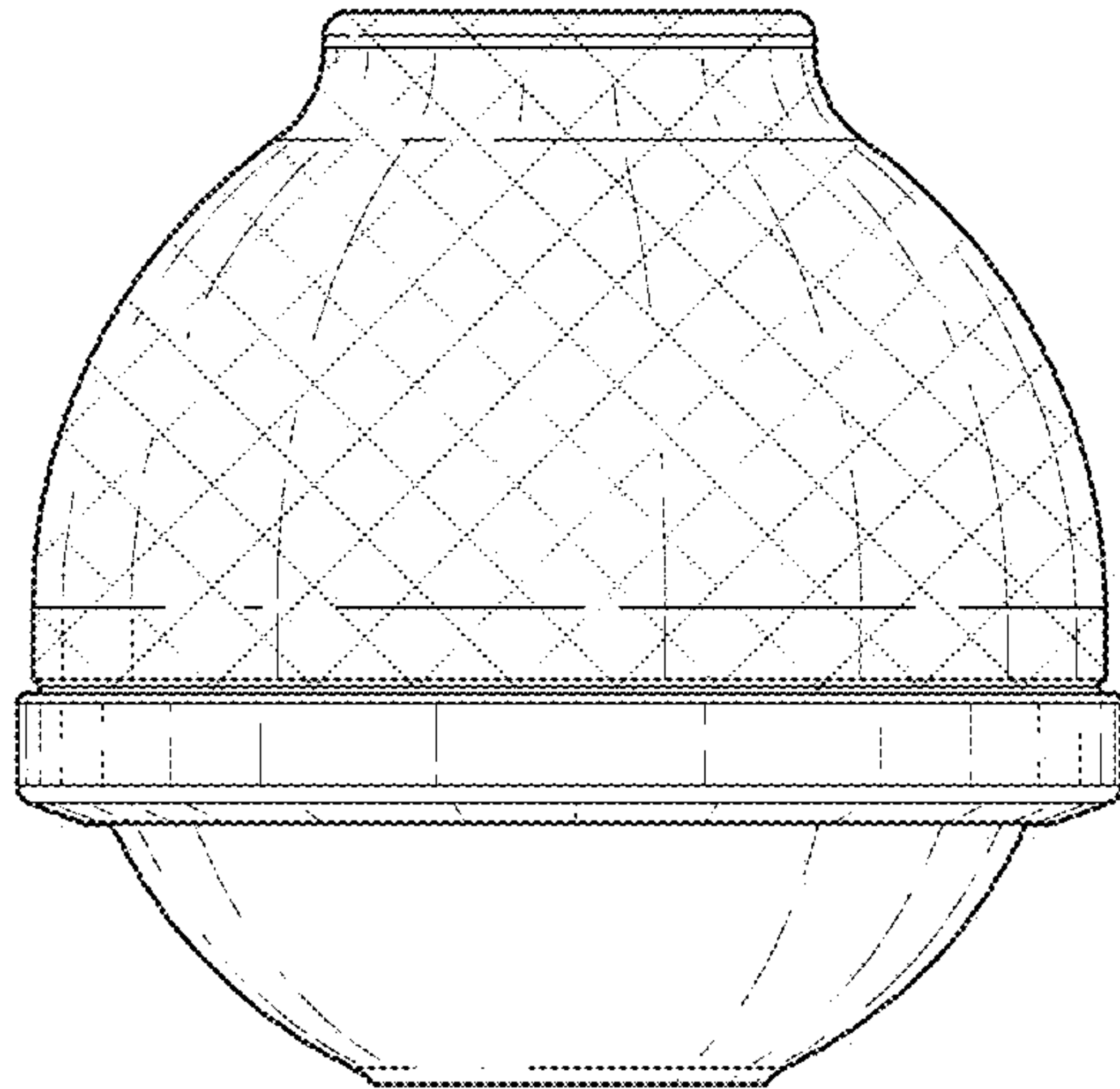

FIG. 10

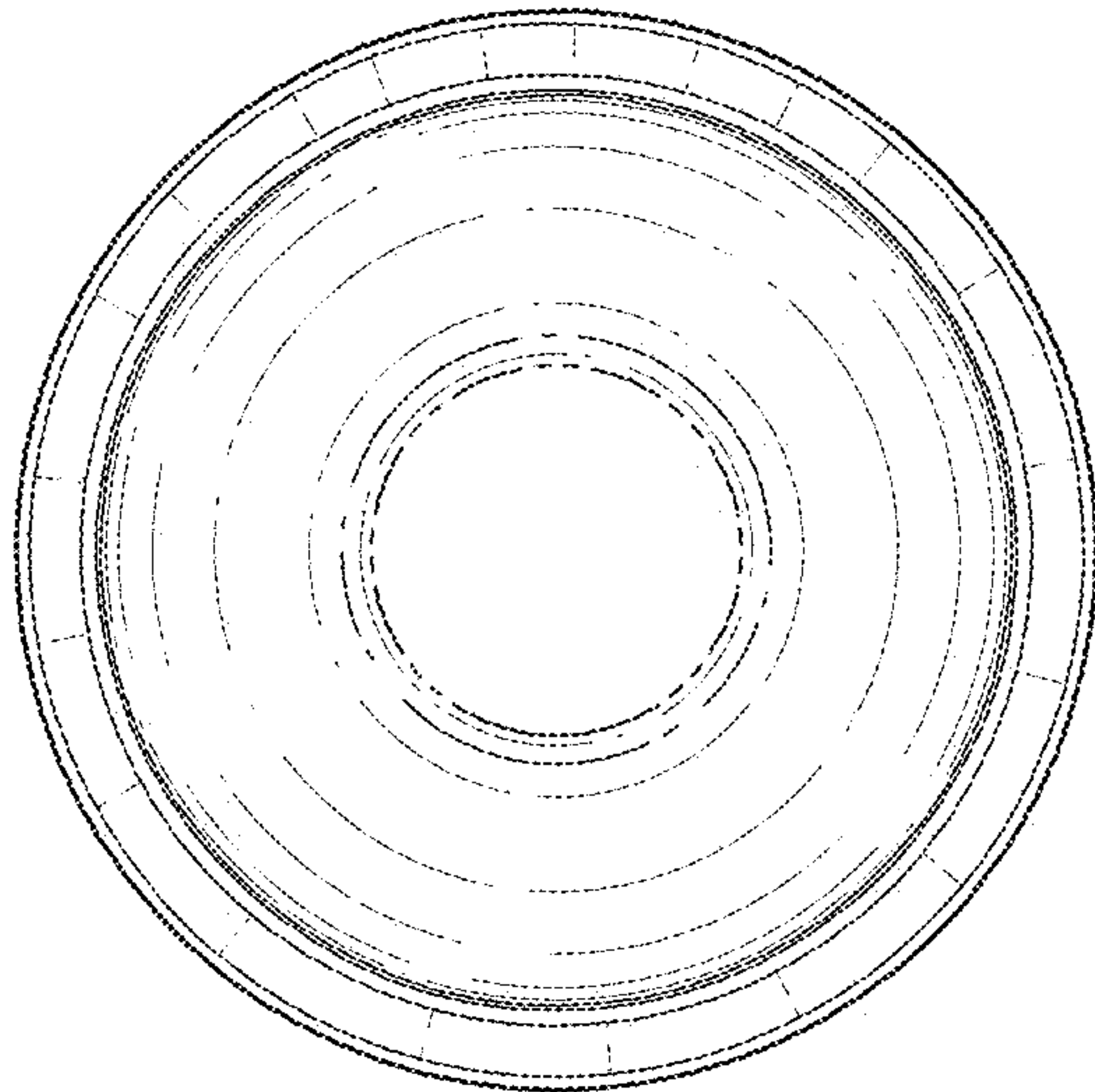

FIG. 9

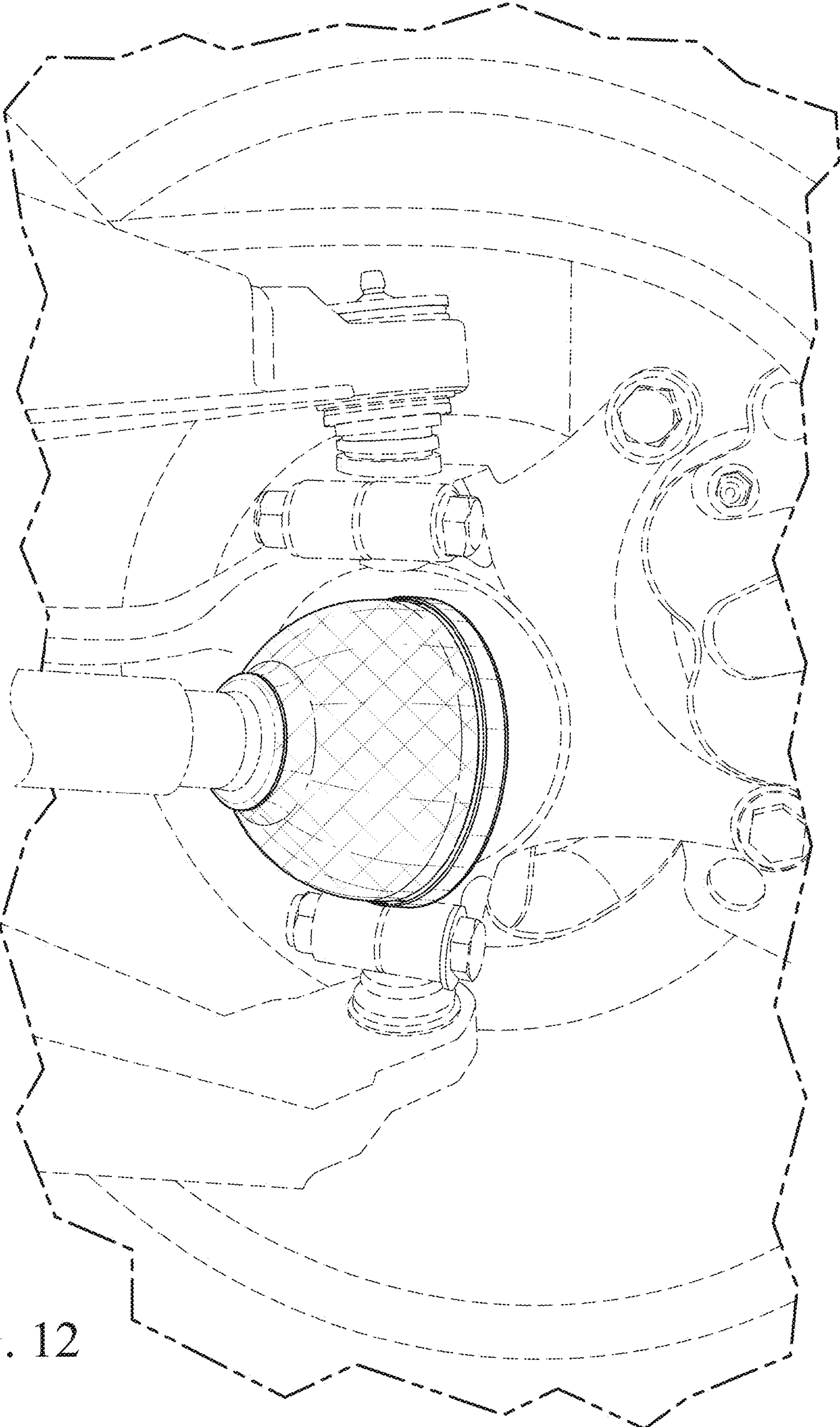

FIG. 12