



US00D878004S

(12) **United States Design Patent**  
**Tsukii**

(10) **Patent No.:** **US D878,004 S**

(45) **Date of Patent:** **\*\* Mar. 10, 2020**

(54) **MAIL BOX WITH AIRPLANE WHEEL PANTS**

(71) Applicant: **Toshikazu Tsukii**, Oro Valley, AZ (US)

(72) Inventor: **Toshikazu Tsukii**, Oro Valley, AZ (US)

(\*\*) Term: **15 Years**

(21) Appl. No.: **29/675,035**

(22) Filed: **Dec. 28, 2018**

(51) **LOC (12) Cl.** ..... **99-00**

(52) **U.S. Cl.**  
USPC ..... **D99/30**

(58) **Field of Classification Search**  
USPC ..... D99/28, 29, 30, 31, 32, 43, 42, 99;  
312/35; 232/1 R, 1 A, 1 C, 1 D, 4 R, 2,  
232/17, 19, 20, 21, 22, 24, 27, 30, 31, 37,  
232/38, 39, 44, 45; D21/430, 447  
CPC ..... A47G 29/12; A47G 29/1201; A47G  
29/1203; A47G 29/1205; A47G 29/1207;  
A47G 29/1209; A47G 29/121; A47G  
29/1212; A47G 29/1214; A47G 29/1216;  
A47G 29/1218; A47G 29/122; A47G  
29/1225; A47G 29/16; A47G 29/00  
See application file for complete search history.

(56) **References Cited**

**U.S. PATENT DOCUMENTS**

D74,296 S *	1/1928	Cameron	.....	D99/30
D77,464 S *	1/1929	Cooper	.....	D99/30
D177,176 S *	3/1956	Hege	.....	D22/126
3,397,481 A *	8/1968	Boese	.....	A63H 27/005 446/52
D319,421 S *	8/1991	Kerezman	.....	D12/126
D342,367 S *	12/1993	Lamancusa	.....	D99/30
D348,969 S *	7/1994	Barbour	.....	D99/30
5,950,918 A *	9/1999	McDonough	.....	A47G 29/1209 232/17
D423,756 S *	4/2000	Borer	.....	D99/30

D439,723 S *	3/2001	Avery	.....	D99/30
D460,599 S *	7/2002	Wrob	.....	D99/30
D484,668 S *	12/2003	Morgan	.....	D99/29
D488,610 S *	4/2004	Coleman	.....	D99/30
D510,785 S *	10/2005	King	.....	D99/30
D548,925 S *	8/2007	Haberman	.....	D99/30
7,364,066 B1 *	4/2008	Wilson	.....	A47G 29/1209 232/17

(Continued)

*Primary Examiner* — Elizabeth J Oswecki

(74) *Attorney, Agent, or Firm* — Eugene Vamos

(57) **CLAIM**

The ornamental design for a mail box with airplane wheel pants, as shown and described.

**DESCRIPTION**

FIG. 1 is a front left perspective view of a mail box with airplane wheel pants with the door in a closed position, showing my new design;  
 FIG. 2 is a front elevation view thereof;  
 FIG. 3 is a back elevation view thereof;  
 FIG. 4 is a right side elevation view thereof;  
 FIG. 5 is a left side elevation view thereof;  
 FIG. 6 is a top plan view thereof;  
 FIG. 7 is a bottom plan view thereof;  
 FIG. 8 is a back left perspective view thereof;  
 FIG. 9 is a front left perspective view of the mail box with airplane wheel pants with the door in an open position;  
 FIG. 10 is a front elevation view thereof;  
 FIG. 11 is a back elevation view thereof;  
 FIG. 12 is a right side elevation view thereof;  
 FIG. 13 is a left side elevation view thereof;  
 FIG. 14 is a top plan view thereof;  
 FIG. 15 is a bottom plan view thereof; and,  
 FIG. 16 is a back left perspective view thereof.

**1 Claim, 12 Drawing Sheets**

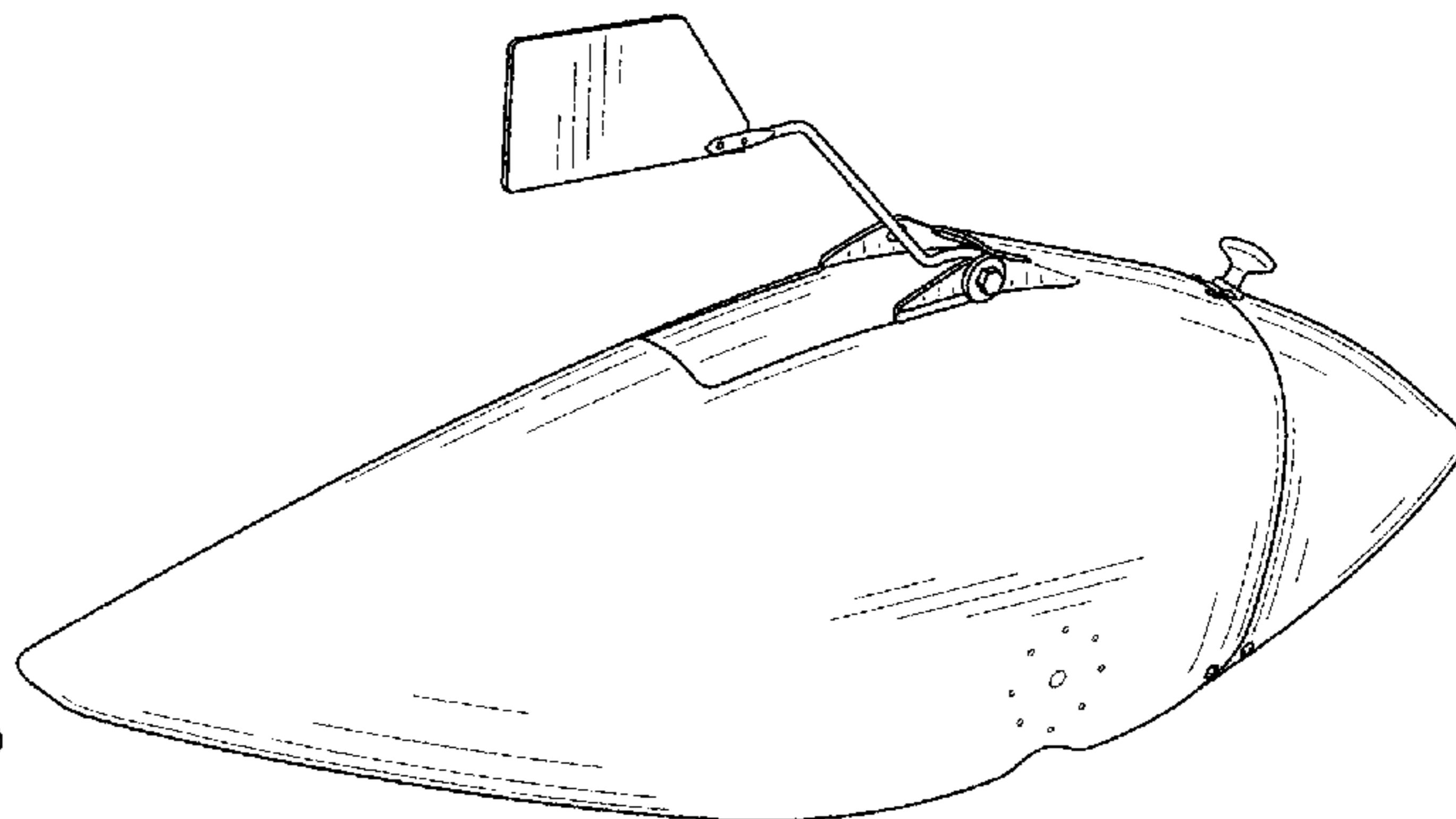
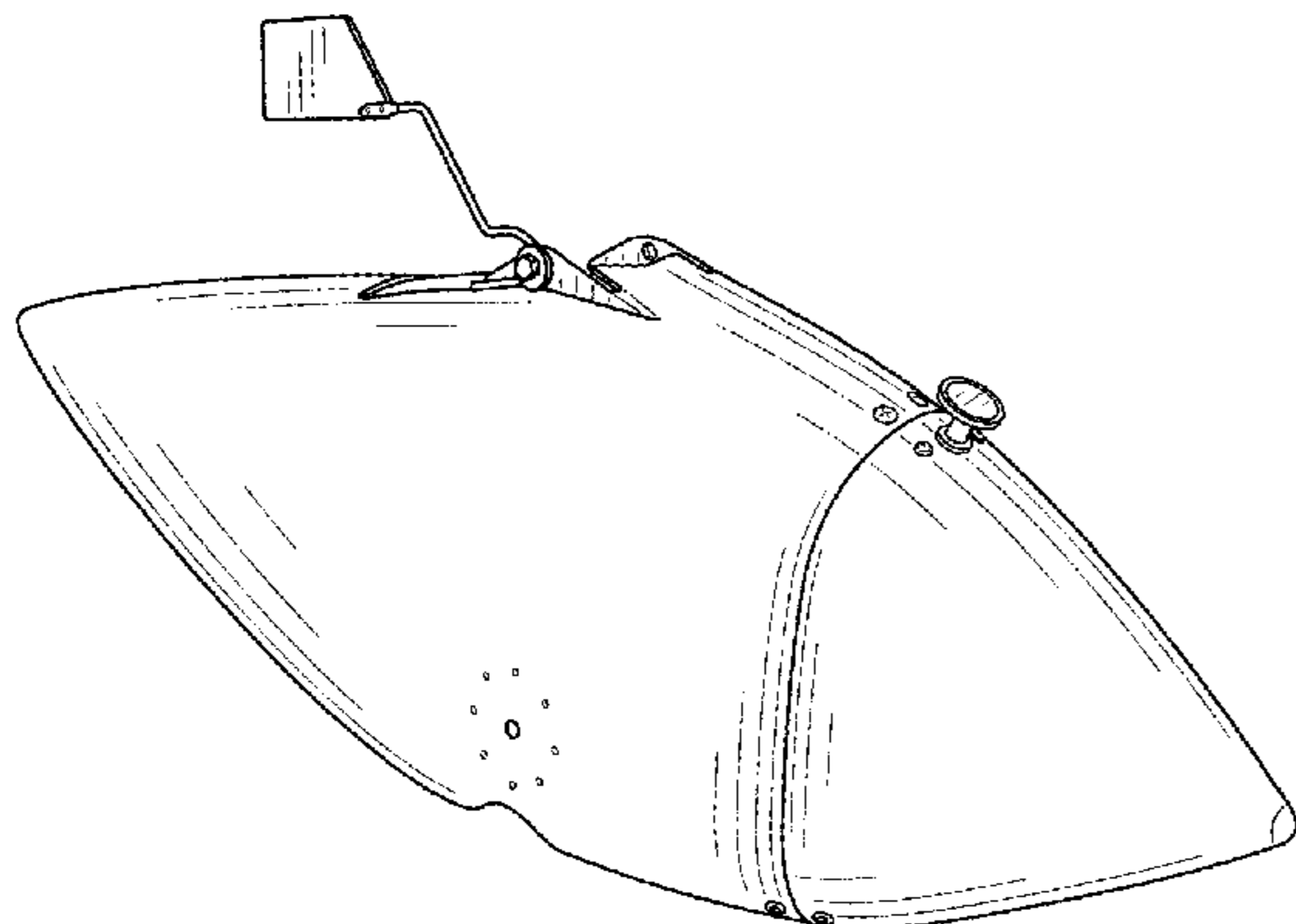

(56)

**References Cited**

U.S. PATENT DOCUMENTS

D634,093 S \* 3/2011 Wagner ..... D99/30  
D837,478 S \* 1/2019 Sanchez ..... D99/30

\* cited by examiner

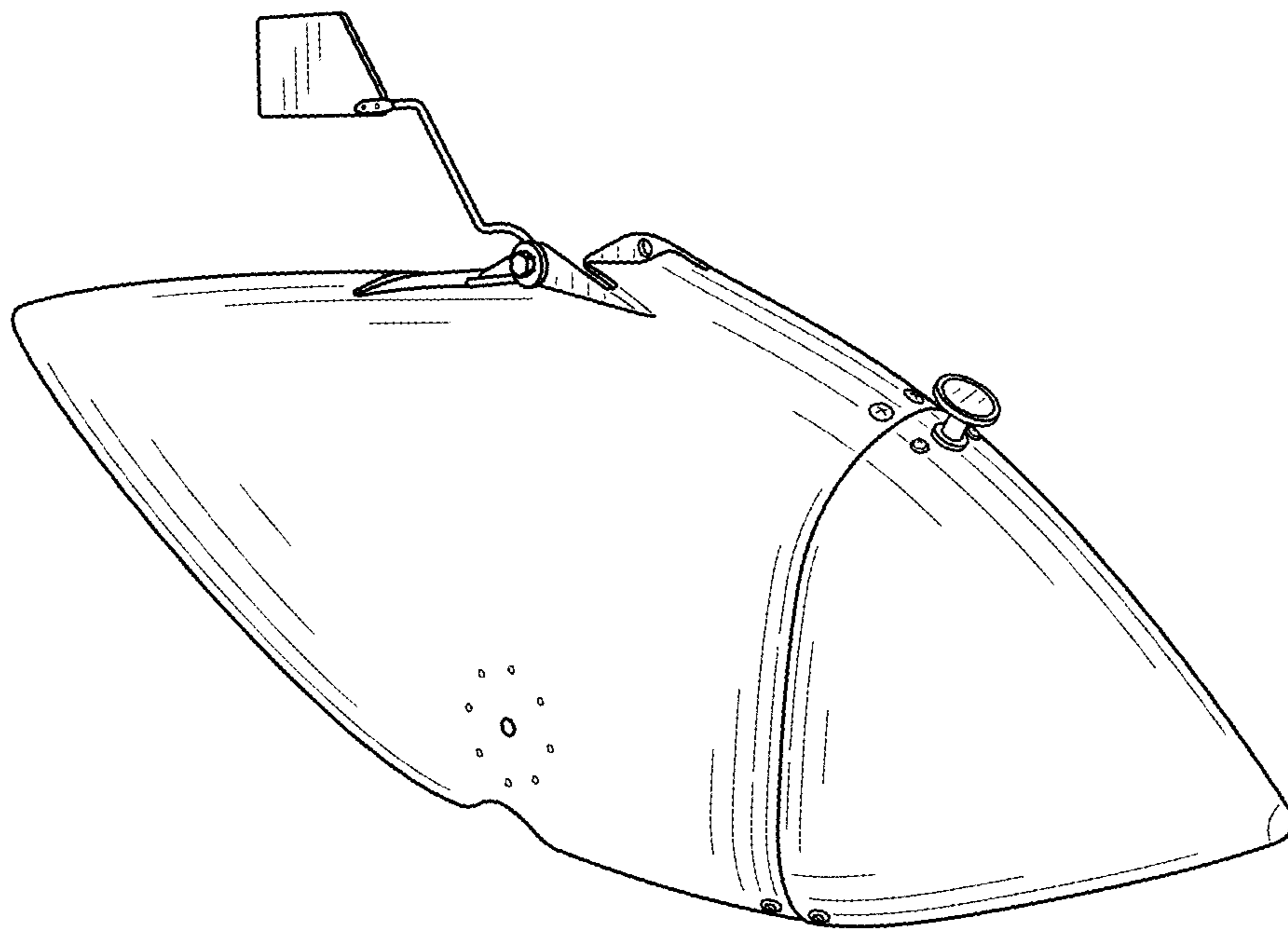

FIG. 1

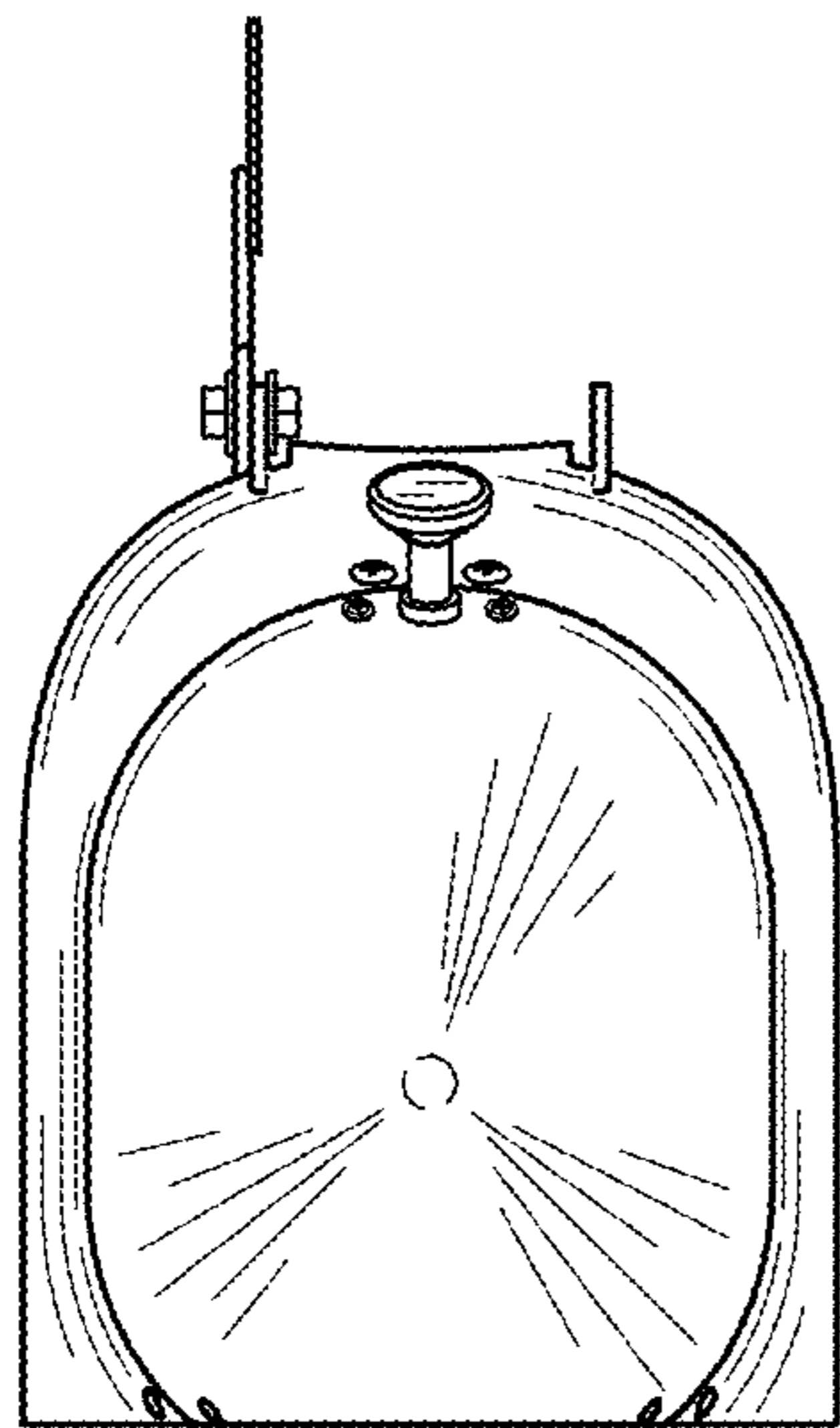

FIG. 2

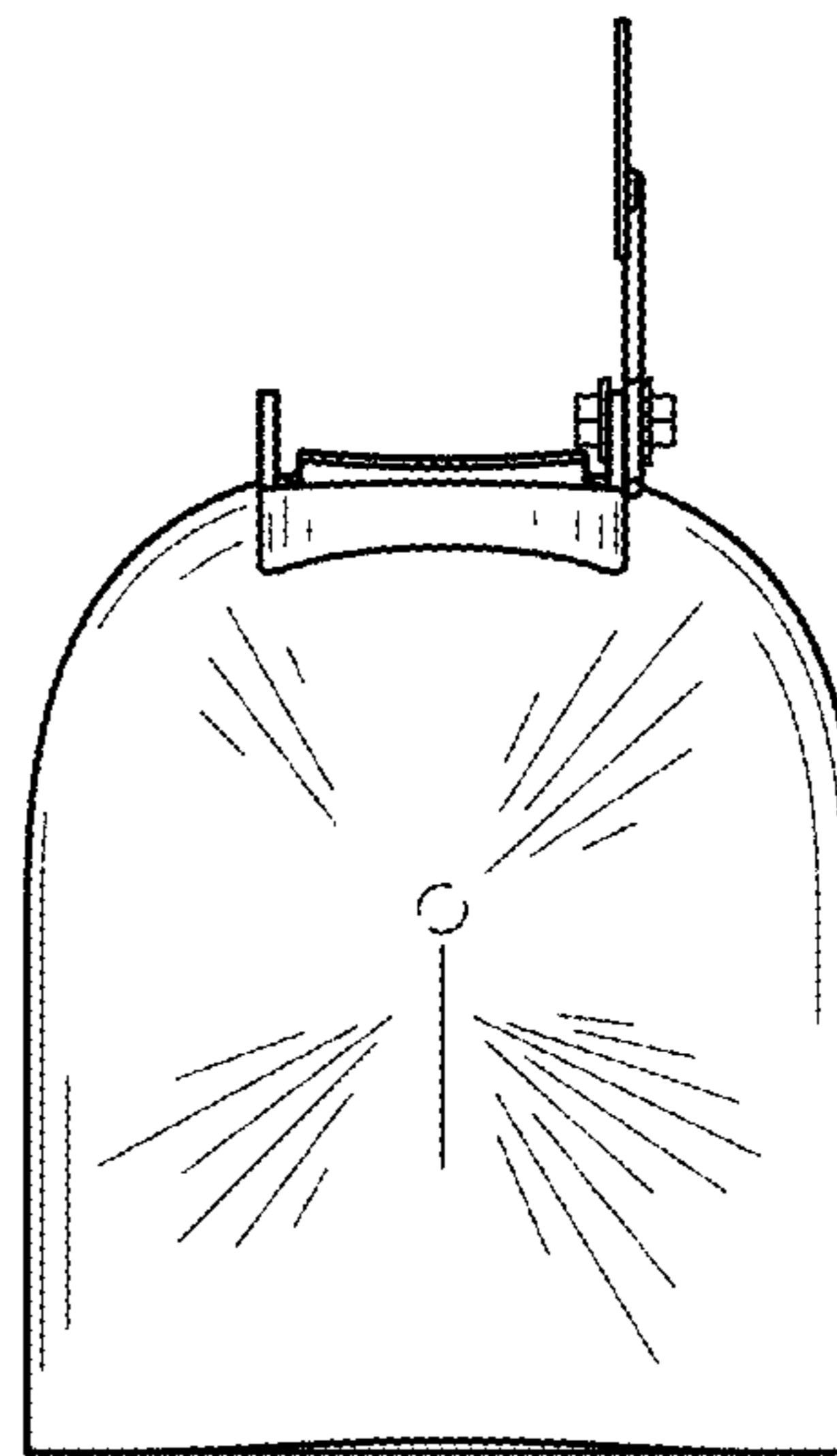

FIG. 3

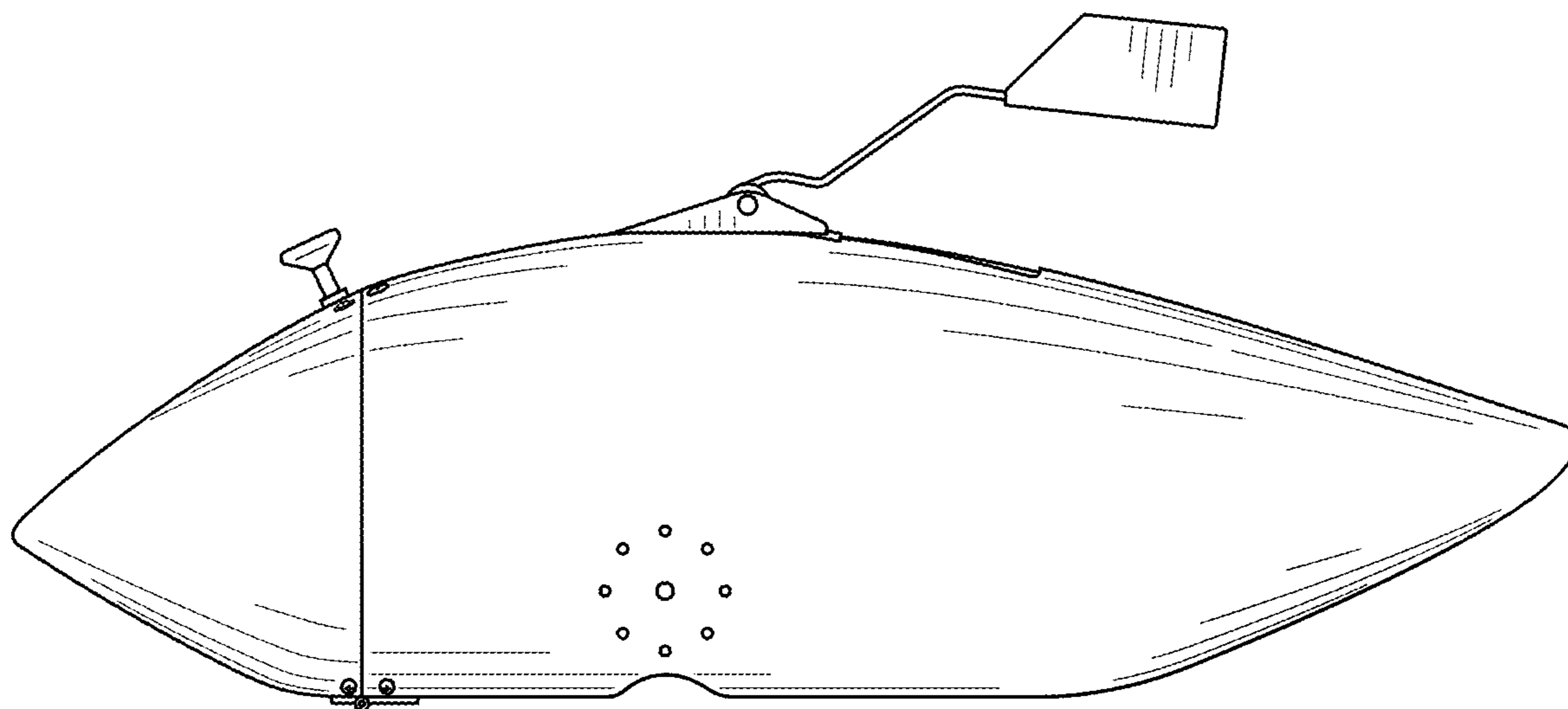

FIG. 4

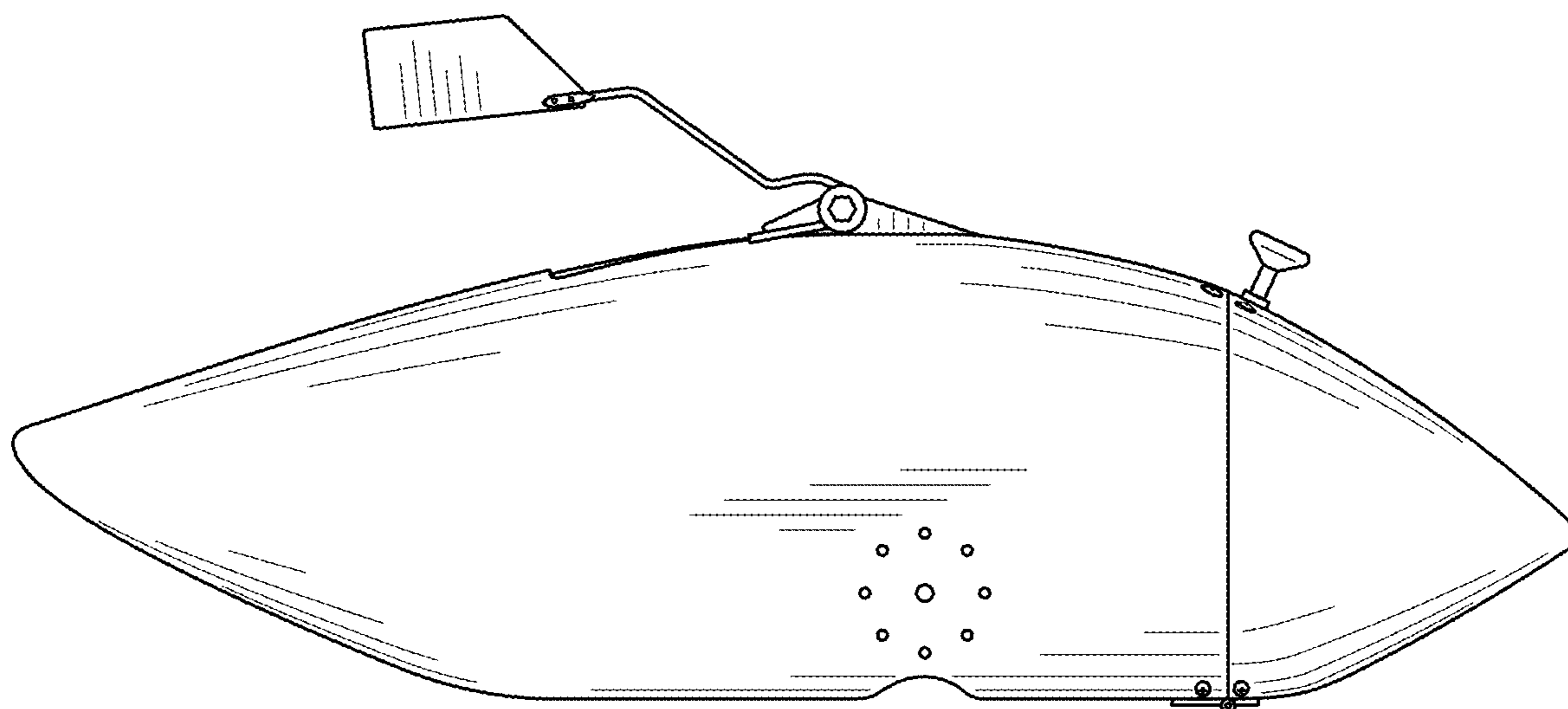

FIG. 5

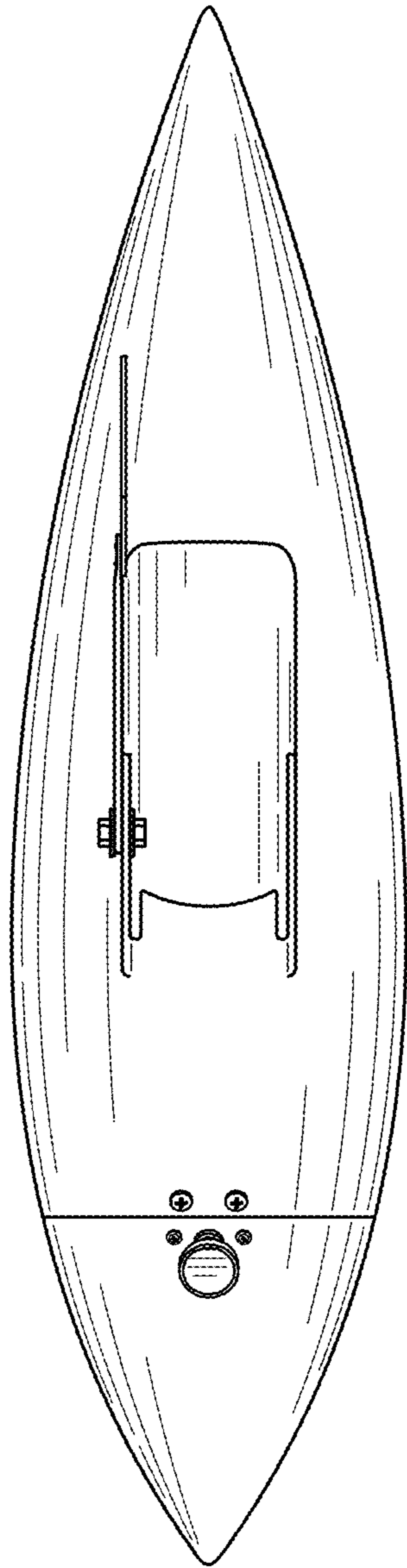

FIG. 6

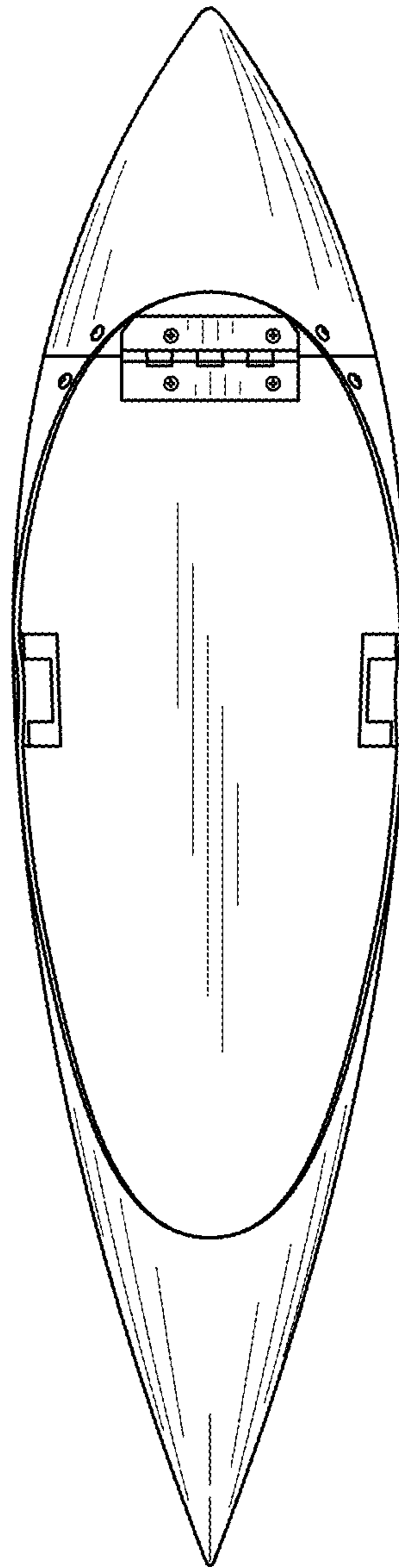

FIG. 7

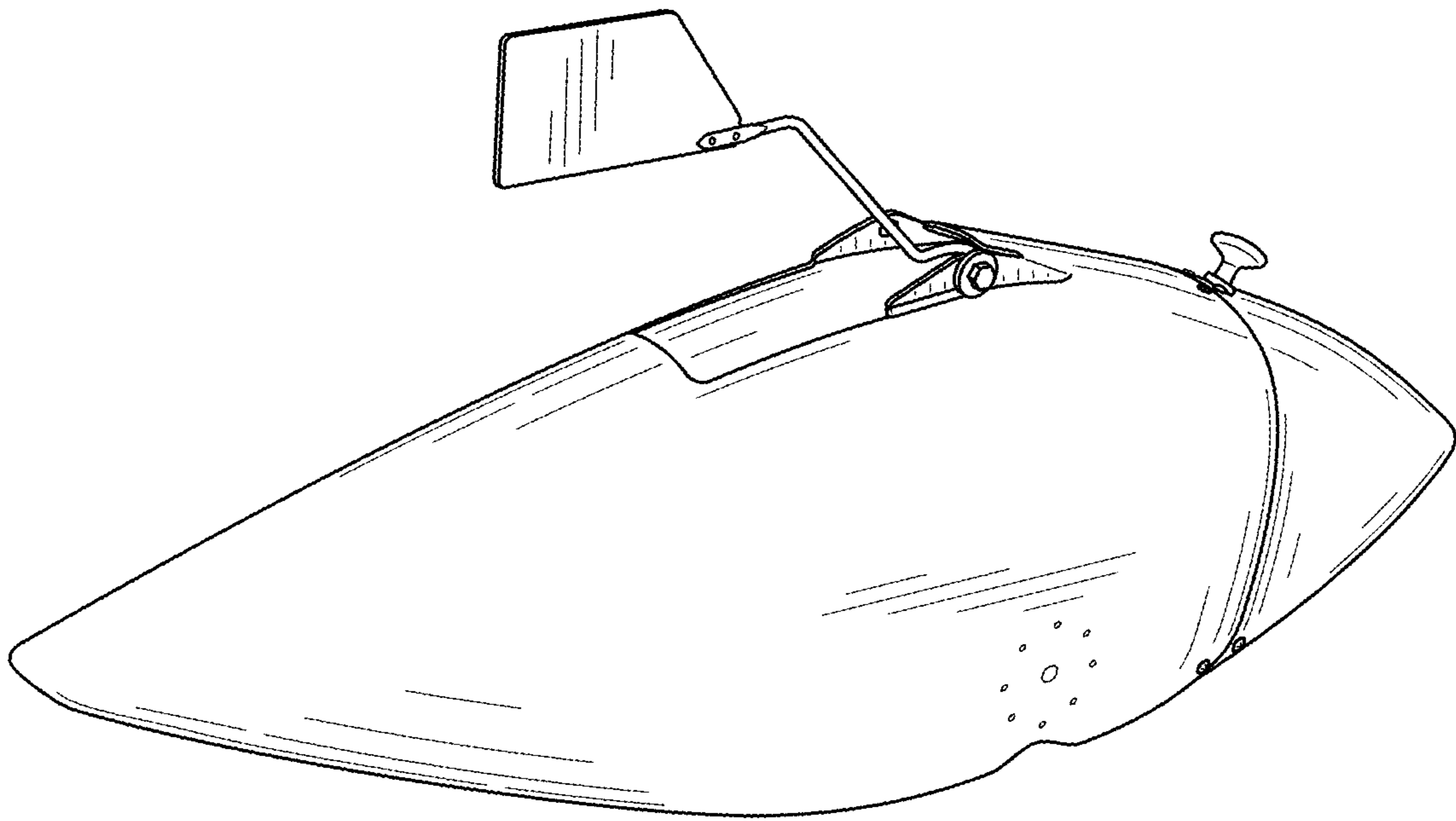

FIG. 8

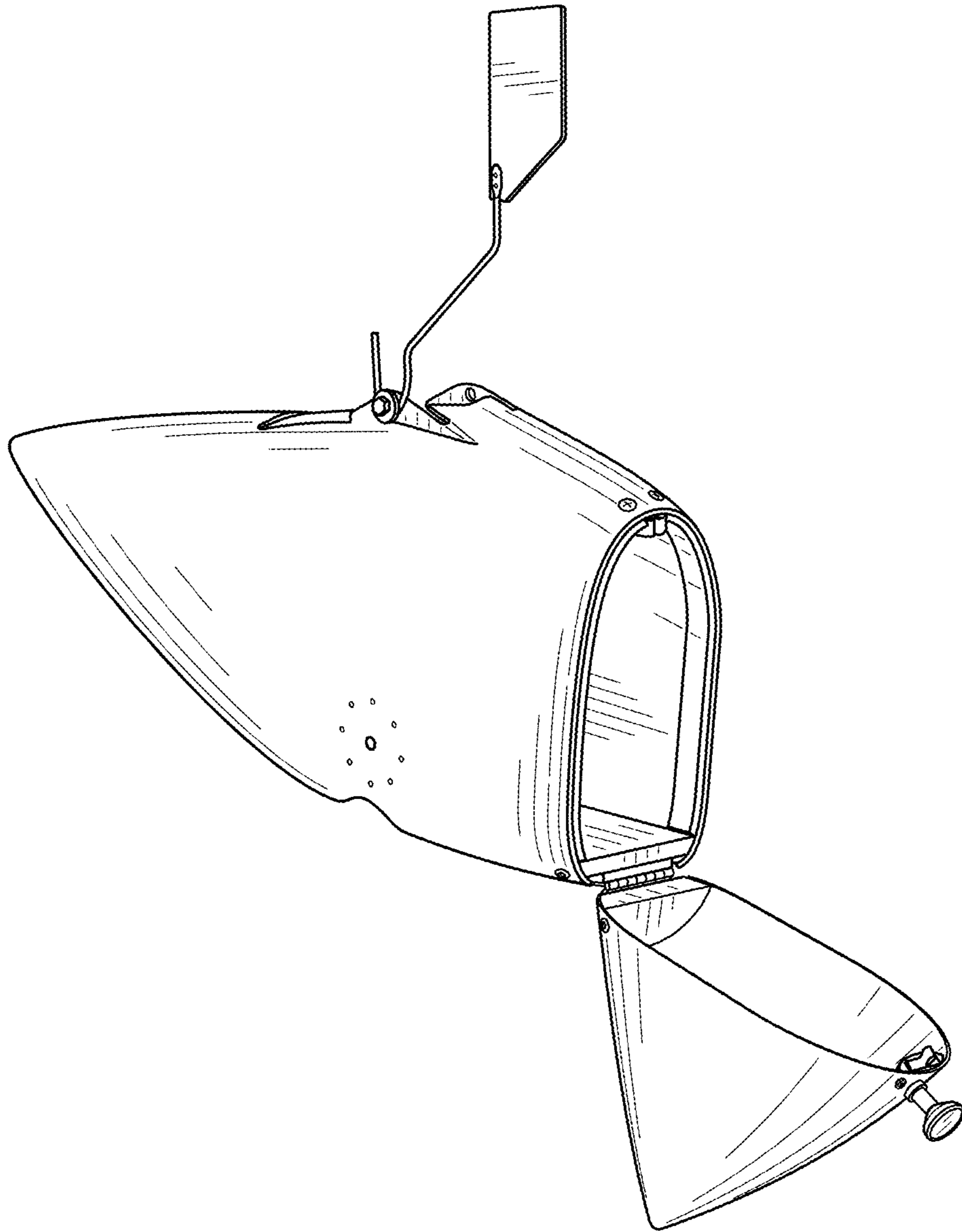

FIG. 9



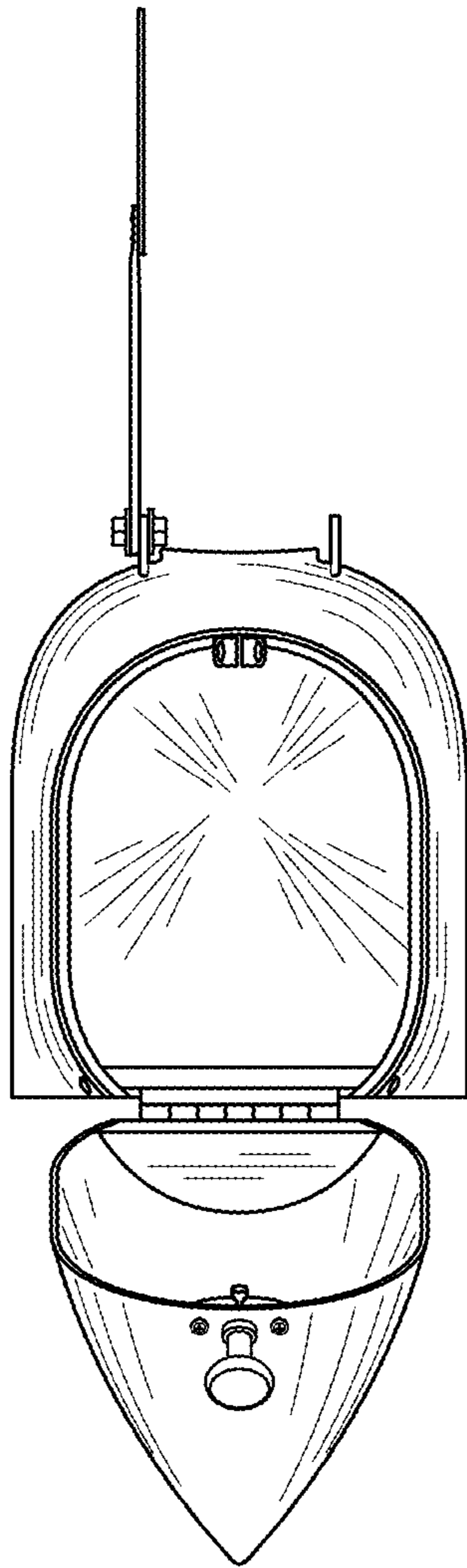

FIG. 10

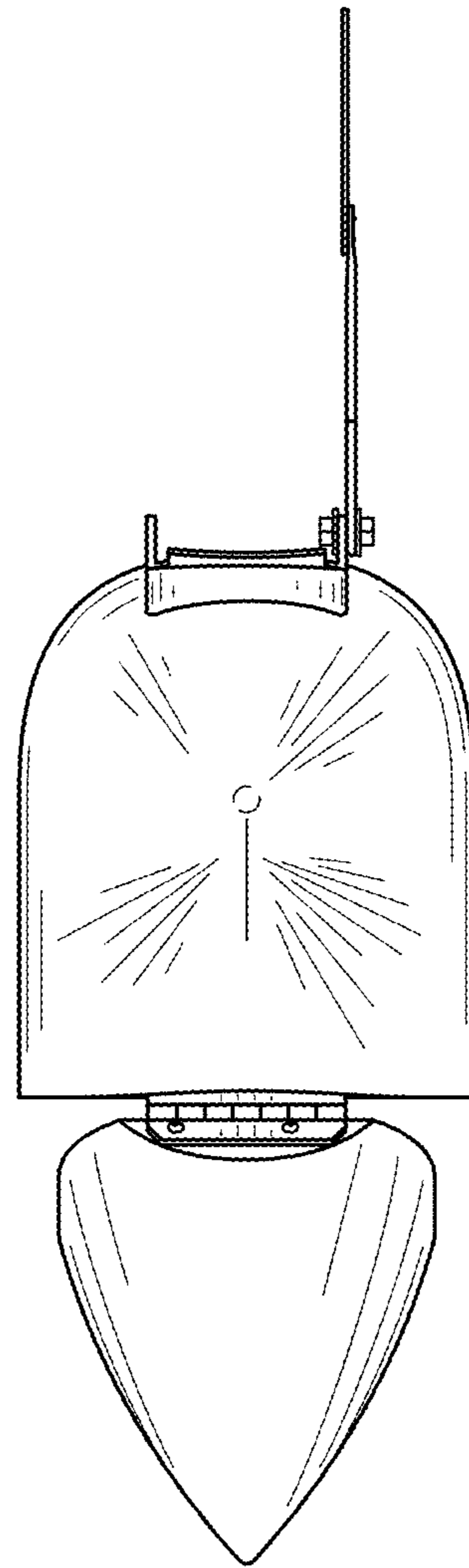

FIG. 11

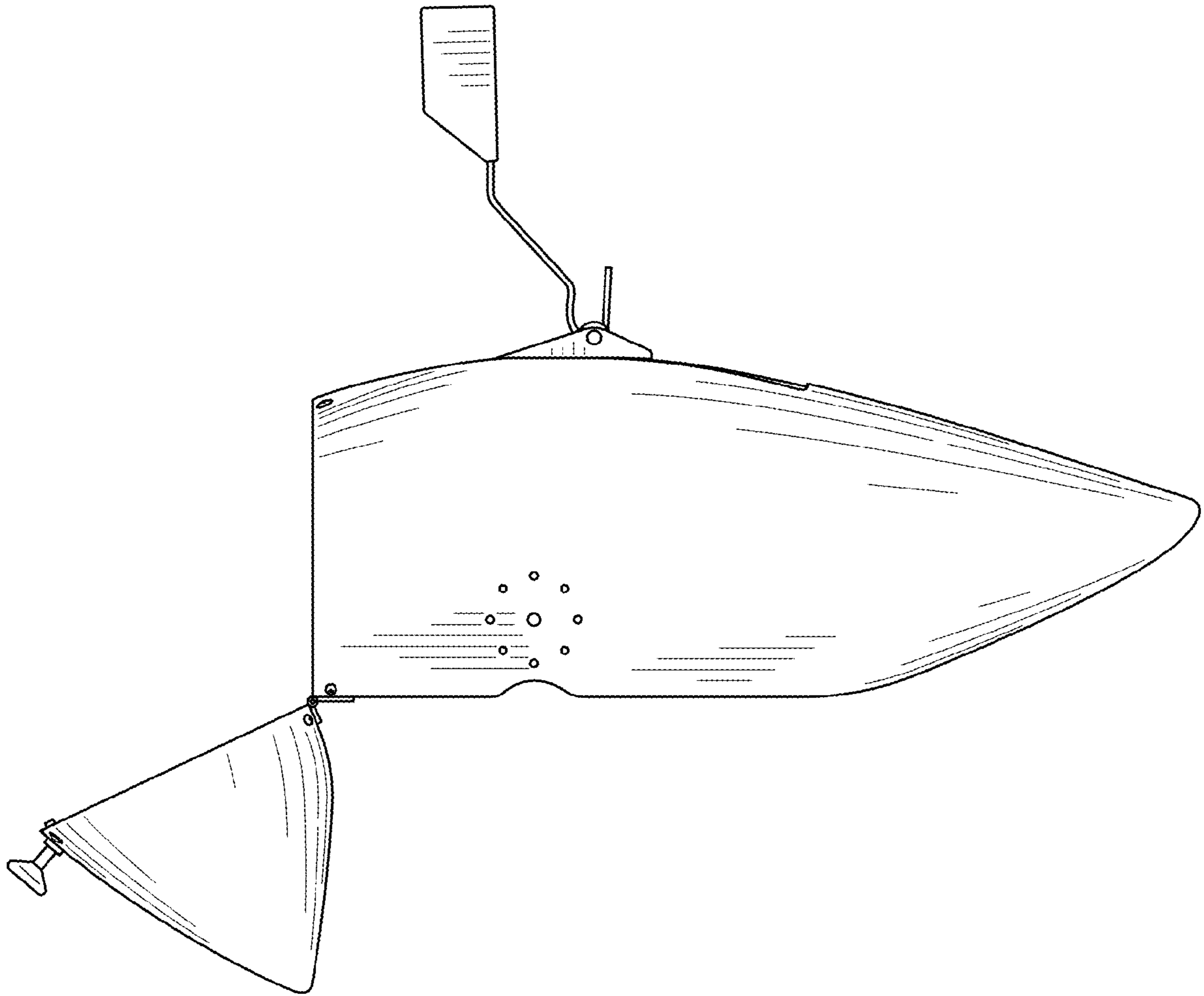

FIG. 12

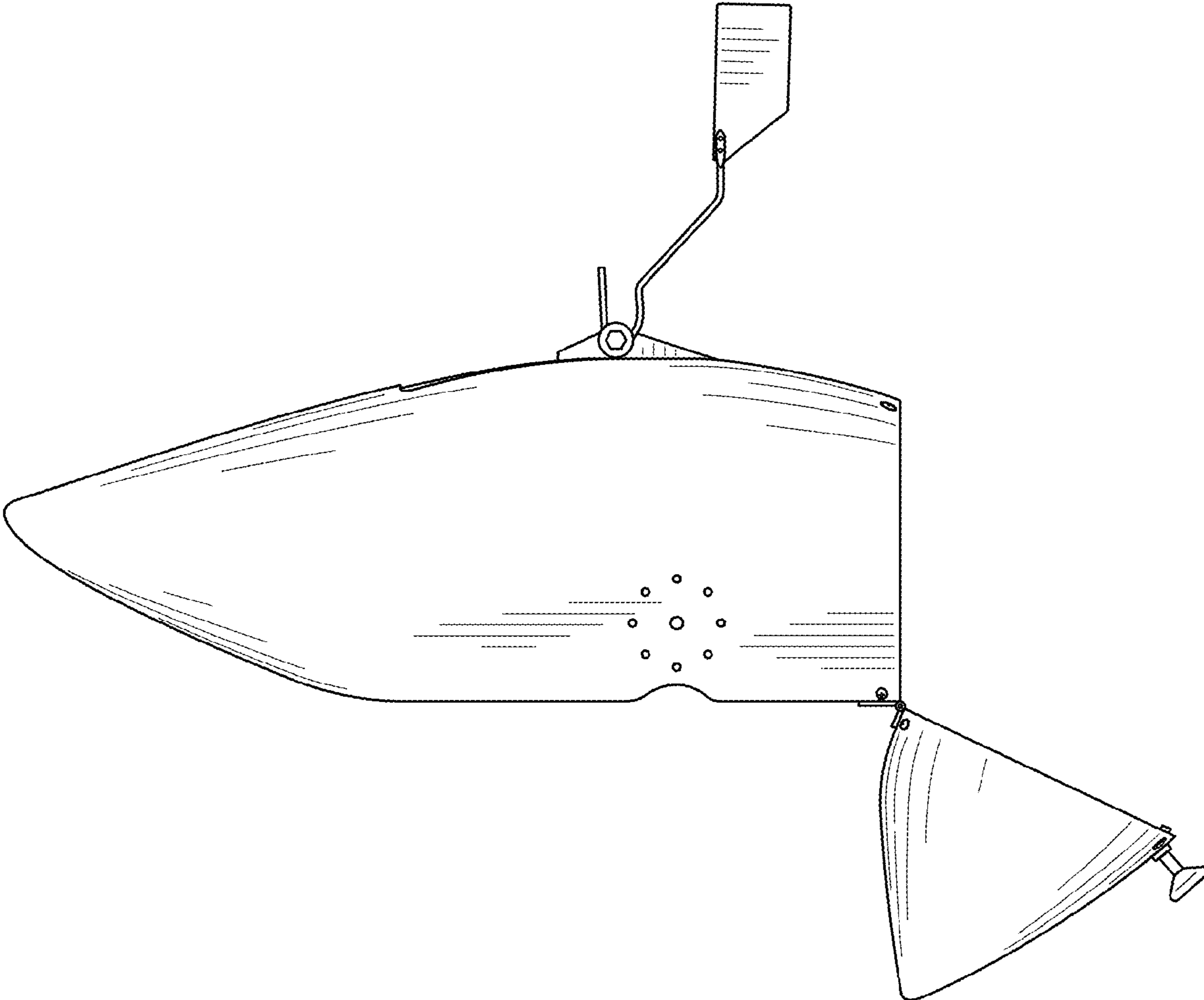

FIG. 13

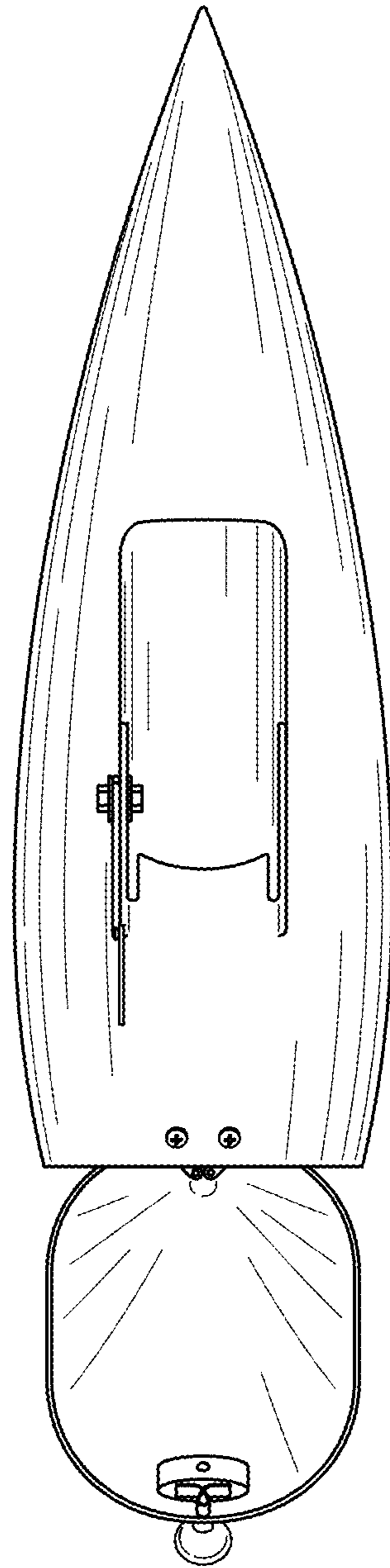

FIG. 14

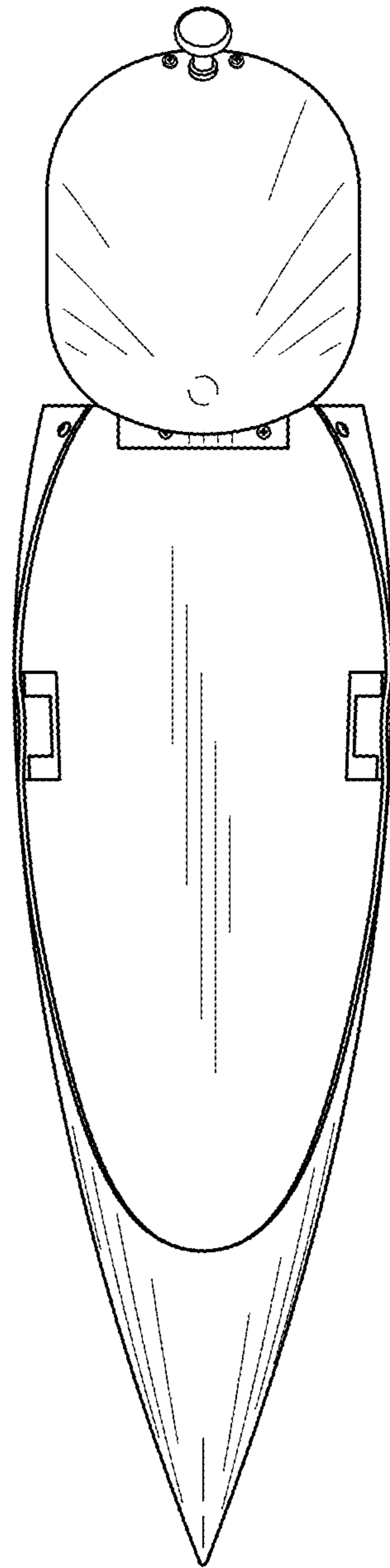

FIG. 15

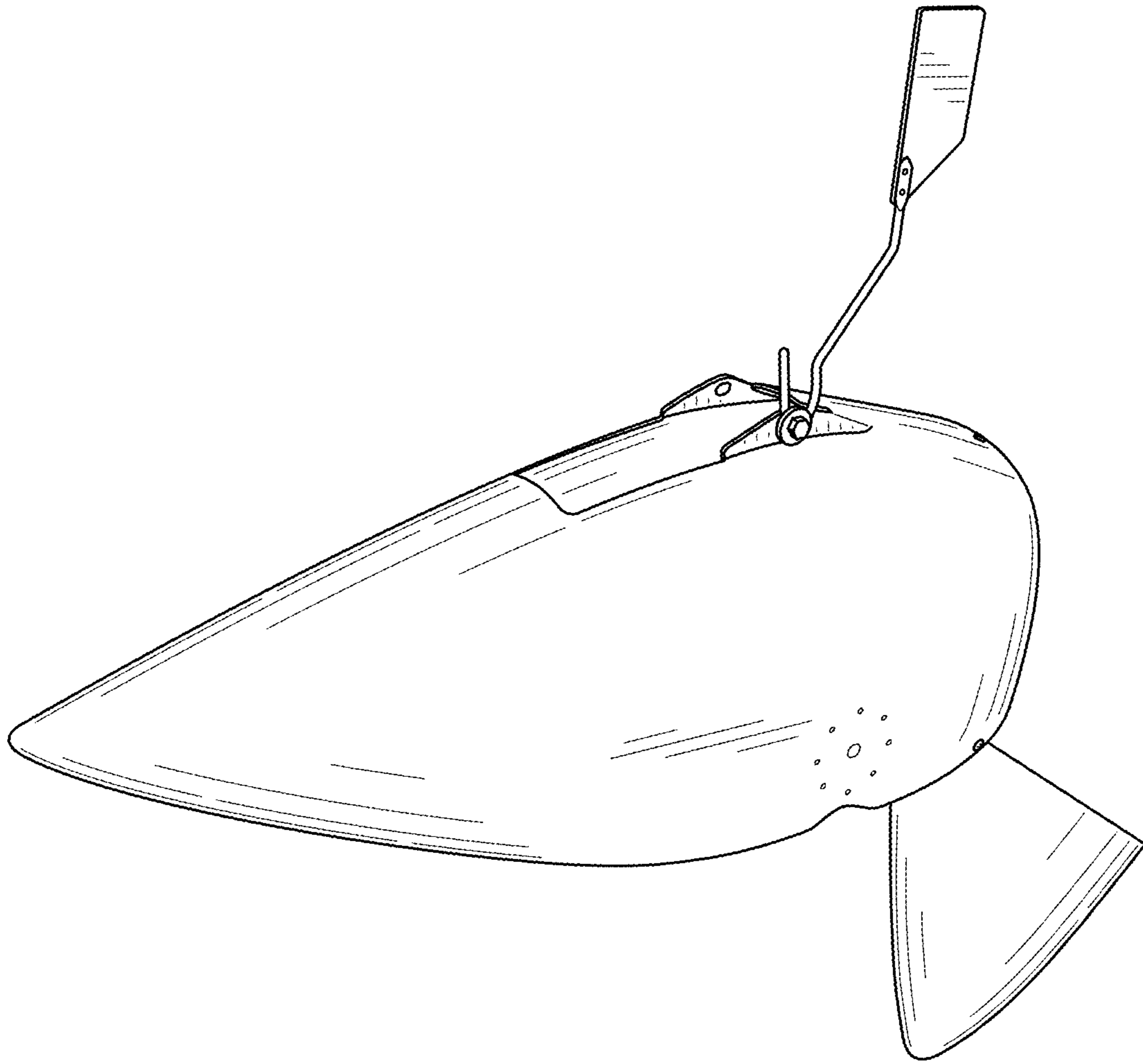

FIG. 16