



US00D877915S

(12) **United States Design Patent**
Ghodsi et al.

(10) **Patent No.:** **US D877,915 S**

(45) **Date of Patent:** **** Mar. 10, 2020**

(54) **CRIB ASSEMBLY**

(71) Applicant: **Stryker Corporation**, Kalamazoo, MI (US)

(72) Inventors: **Seyed Behrad Ghodsi**, Portage, MI (US); **Justin Jon Raymond**, Jackson, MI (US)

(73) Assignee: **Stryker Corporation**, Kalamazoo, MI (US)

(**) Term: **15 Years**

(21) Appl. No.: **29/664,884**

(22) Filed: **Sep. 28, 2018**

(51) **LOC (12) Cl.** **24-02**

(52) **U.S. Cl.**
USPC **D24/183**

(58) **Field of Classification Search**
USPC D24/177, 183–185, 200, 211, 215,
D24/206–208; D6/596, 601, 604, 606,
D6/716.4
CPC A61G 13/0054; A61G 7/103
See application file for complete search history.

(56) **References Cited**

U.S. PATENT DOCUMENTS

3,254,348 A 6/1966 Addario
3,940,811 A 3/1976 Tomikawa et al.
(Continued)

FOREIGN PATENT DOCUMENTS

CN 2251310 Y 4/1997
GB 2405582 A 3/2005
(Continued)

OTHER PUBLICATIONS

Direct Healthcare Services Ltd., “Dyna-Form Low Air Loss System User Manual”, Version 01, Mar. 1, 2013, 16 pages.

(Continued)

Primary Examiner — Susan Bennett Hattan

Assistant Examiner — Omeed Agilee

(74) *Attorney, Agent, or Firm* — Howard & Howard Attorneys PLLC

(57) **CLAIM**

The ornamental design for a crib assembly, as shown and described.

DESCRIPTION

The file of this patent contains at least one drawing executed in color. Copies of this patent with color drawing(s)/photographs(s) will be provided by the Office upon request and payment of the necessary fee.

FIG. 1 is a top view of a crib assembly.

FIG. 2 is a top front perspective view of the crib assembly.

FIG. 3 is another top front perspective view of the crib assembly.

FIG. 4 is a right side view of the crib assembly.

FIG. 5 is a left side view of the crib assembly.

FIG. 6 is a top front, right side, perspective view of the crib assembly.

FIG. 7 is a top front, left side, perspective view of the crib assembly.

FIG. 8 is a top back, left side, perspective view of the crib assembly.

FIG. 9 is a bottom view of the crib assembly.

FIG. 10 is a front, right side, bottom perspective view of the crib assembly.

FIG. 11 is another front, right side, bottom perspective view of the crib assembly.

FIG. 12 is a back, right side, bottom perspective view of the crib assembly.

FIG. 13 is a back, left side, bottom perspective view of the crib assembly.

FIG. 14 is another back, left side, bottom perspective view of the crib assembly; and,

FIG. 15 is a front, left side, bottom perspective view of the crib assembly.

1 Claim, 9 Drawing Sheets
(9 of 9 Drawing Sheet(s) Filed in Color)



(56)

References Cited

U.S. PATENT DOCUMENTS

D246,816 S * 1/1978 Tam D6/596
 4,336,621 A 6/1982 Schwartz et al.
 D275,322 S * 8/1984 Nakao D24/183
 4,605,582 A 8/1986 Sias et al.
 4,665,573 A 5/1987 Fiore
 4,947,500 A 8/1990 Seiler
 5,007,124 A 4/1991 Raburn et al.
 5,109,559 A 5/1992 West
 5,179,742 A 1/1993 Oberle
 5,180,619 A 1/1993 Landi et al.
 5,280,657 A 1/1994 Stagg
 5,482,355 A 1/1996 Franzen, Jr.
 5,491,854 A 2/1996 Music
 5,611,096 A 3/1997 Bartlett et al.
 5,617,595 A 4/1997 Landi et al.
 5,630,238 A 5/1997 Weismiller et al.
 5,794,289 A 8/1998 Wortman et al.
 D408,539 S * 4/1999 Simpkins D24/184
 6,115,861 A 9/2000 Reeder et al.
 6,269,504 B1 8/2001 Romano et al.
 6,286,166 B1 9/2001 Henley et al.
 6,367,106 B1 4/2002 Gronsmann
 6,387,065 B1 5/2002 Tumey
 D461,900 S * 8/2002 Siepmann 5/600
 6,430,766 B1 8/2002 Henley et al.
 6,658,676 B1 12/2003 Persson et al.
 6,687,937 B2 2/2004 Harker
 6,701,556 B2 3/2004 Romano et al.
 6,701,558 B2 3/2004 VanSteenburg
 6,718,584 B2 4/2004 Rabaiotti et al.
 6,735,799 B1 5/2004 Ellis et al.
 6,829,796 B2 12/2004 Salvatini et al.
 D502,350 S * 3/2005 O'Reagan D6/596
 7,060,213 B2 6/2006 Pearce
 D524,086 S * 7/2006 Garrigues D6/596
 7,191,480 B2 3/2007 Romano et al.
 7,191,482 B2 3/2007 Romano et al.
 D552,738 S * 10/2007 Helfet D24/183
 D555,250 S * 11/2007 Wells D24/184
 7,461,425 B2 12/2008 Chambers et al.
 7,464,425 B2 12/2008 Chambers et al.
 7,469,432 B2 12/2008 Chambers
 7,469,436 B2 12/2008 Meyer et al.
 7,480,953 B2 1/2009 Romano et al.
 D604,421 S * 11/2009 Albrecht D24/183
 7,617,555 B2 11/2009 Romano et al.
 7,641,623 B2 1/2010 Biondo et al.
 7,648,392 B2 1/2010 Chambers et al.
 7,666,341 B2 2/2010 Pearce
 7,685,664 B2 3/2010 Stolpmann et al.
 7,712,164 B2 5/2010 Chambers
 7,712,171 B2 5/2010 Butler
 7,802,332 B2 9/2010 Kummer et al.
 7,886,386 B2 2/2011 Balonick et al.
 7,904,976 B2 3/2011 Hakamiun et al.
 7,914,611 B2 3/2011 Vrzalik et al.
 7,966,680 B2 6/2011 Romano et al.
 8,069,514 B2 12/2011 Poulos et al.
 8,090,478 B2 1/2012 Skinner et al.
 8,108,957 B2 2/2012 Richards et al.
 8,117,701 B2 2/2012 Bobey et al.
 8,118,920 B2 2/2012 Vrzalik et al.
 8,196,241 B2 6/2012 Balonick et al.
 8,201,292 B2 6/2012 Dionne et al.
 8,235,922 B2 8/2012 Rowe et al.
 8,260,475 B2 9/2012 Receveur
 8,332,979 B2 12/2012 Flick et al.
 D674,499 S * 1/2013 Palm D24/200
 8,372,182 B2 2/2013 Vrzalik et al.
 8,397,326 B2 3/2013 Lafleche et al.
 8,413,277 B2 * 4/2013 Davis A61G 7/1011
 137/512.1
 8,429,778 B2 4/2013 Receveur et al.
 8,434,748 B1 5/2013 Pearce et al.
 8,437,876 B2 5/2013 Receveur et al.

8,490,233 B2 7/2013 Essers
 8,572,778 B2 11/2013 Newkirk et al.
 8,601,620 B2 12/2013 Romano et al.
 8,620,477 B2 12/2013 Skinner et al.
 8,628,067 B2 1/2014 Pearce et al.
 8,689,373 B2 4/2014 Caines
 8,712,591 B2 4/2014 Receveur
 8,745,788 B2 6/2014 Bhai
 8,844,079 B2 9/2014 Skinner et al.
 8,845,562 B2 9/2014 Receveur et al.
 8,918,930 B2 12/2014 Stroh et al.
 8,919,750 B2 12/2014 Pearce et al.
 D723,839 S * 3/2015 Bond D5/62
 9,009,891 B2 4/2015 Receveur et al.
 9,009,892 B2 4/2015 Lachenbruch et al.
 9,049,943 B2 6/2015 Caminade et al.
 D735,876 S * 8/2015 Wolff D24/215
 9,107,511 B2 8/2015 Skinner et al.
 D745,682 S * 12/2015 Ziegler D24/184
 9,254,231 B2 2/2016 Vrzalik et al.
 9,315,648 B2 4/2016 Nilson et al.
 9,320,664 B2 4/2016 Newkirk et al.
 9,358,168 B2 6/2016 Williamson et al.
 9,414,977 B2 8/2016 Ponsi et al.
 9,462,893 B2 10/2016 Romano et al.
 9,526,348 B2 12/2016 Richards et al.
 9,526,349 B2 12/2016 Lafleche et al.
 9,655,457 B2 5/2017 Meyer et al.
 9,707,141 B2 7/2017 Bobey et al.
 9,835,344 B2 12/2017 Vrzalik et al.
 9,849,051 B2 12/2017 Newkirk et al.
 9,907,408 B2 3/2018 Vrzalik et al.
 9,907,718 B2 3/2018 Weitzel et al.
 9,913,770 B2 3/2018 Lachenbruch et al.
 D816,237 S * 4/2018 Roberts D24/207
 9,943,172 B2 4/2018 Lachenbruch et al.
 D855,817 S * 8/2019 Kessler D24/206
 2005/0034230 A1 * 2/2005 Weedling A61G 7/103
 5/81.1 R
 2006/0005314 A1 1/2006 Lee
 2006/0021133 A1 * 2/2006 Davis A61G 7/1028
 5/81.1 R
 2007/0143928 A1 6/2007 Biggie et al.
 2008/0040860 A1 2/2008 Price
 2009/0013470 A1 1/2009 Richards et al.
 2010/0076356 A1 3/2010 Biondo et al.
 2010/0212087 A1 8/2010 Leib et al.
 2011/0163885 A1 7/2011 Poulos et al.
 2013/0014324 A1 1/2013 Receveur et al.
 2013/0231596 A1 9/2013 Hornbach et al.
 2014/0031730 A1 1/2014 Hornbach et al.
 2015/0074914 A1 3/2015 Caminade
 2015/0164720 A1 6/2015 Gibson et al.
 2016/0157631 A1 6/2016 Milnes et al.
 2016/0184154 A1 6/2016 Lafleche et al.
 2016/0326674 A1 11/2016 Goijarts et al.
 2016/0356676 A1 12/2016 Sauser et al.
 2016/0361215 A1 12/2016 Gibson et al.
 2017/0027791 A1 2/2017 McKnight et al.
 2017/0151113 A1 6/2017 Lachenbruch et al.
 2017/0251824 A1 9/2017 Pearce
 2017/0251825 A1 9/2017 Pearce
 2017/0254379 A1 9/2017 Whatcott
 2018/0104123 A1 4/2018 Newkirk et al.
 2018/0369038 A1 12/2018 Bhimavarapu et al.

FOREIGN PATENT DOCUMENTS

WO 9507679 A2 3/1995
 WO 02065877 A1 8/2002
 WO 2013086197 A1 6/2013

OTHER PUBLICATIONS

Drive, "Med Aire Plus 8" Alternating Pressure and Low Air Loss Mattress Replacement System Operator's Manual, Item #14029, Control Unit 14029XP), Rev. 4, Mar. 15, 2016, 20 pages.

(56)

References Cited

OTHER PUBLICATIONS

- Gaymar Industries Inc., “Air Express Alternating Low Pressure Therapy Operator’s Manual”, Apr. 2012, 113 pages.
- Gaymar Industries Inc., “Air Express C1000DF Service Manual”, Jul. 2007, 16 pages.
- Gaymar Industries Inc., “Air Express LAL P1500 Low Air Loss Therapy System Operator’s Manual”, Rev. B, Apr. 2010, 32 pages.
- Gaymar Industries Inc., “Aire Twin Alternating Pressure and Low-Loss Therapy Mattress Replacement Systems ATC80, ATM500, ATM800, ATW5000, ATW8000 Operator’s Manual”, May 2005, 8 pages.
- Gaymar Industries Inc., “Auto Aire Select Dynamic Low-Air Loss Therapy Service Manual”, Rev. A, Apr. 2010, 28 pages.
- Gaymar Industries Inc., Auto Aire Select Dynamic Low-Air Loss Therapy With Alternating Pressure and Active Sensor Technology Ref C2500MES Control Unit, Ref M2500S Series Mattress, Ref X3580S Operator’s Manual Rev. B, Sep. 2010, 42 pages.
- Gaymar Industries Inc., “Auto Aire Select Dynamic Low-Air Loss Therapy With Alternating Pressure and Active Sensor Technology Ref C2500MS Control Unit, Ref M2500S Series Mattress, Ref Auto Aire Select Safety Mattress Service Manual”, Rev. B, Sep. 2010, 14 pages.
- Gaymar Industries Inc., “Auto Sure-Float Ref C1000MS/ C1000MES Control Unit; Ref M1001S/M1002S Series Mattress Operator’s Manual”, Rev. B, Sep. 2010, 128 pages.
- Gaymar Industries Inc., “Clini-Dyne Lateral Rotation System CLP2000 Control Unit, CLM Series Mattress Service Manual”, Rev. A, Oct. 2010, 18 pages.
- Gaymar Industries Inc., “Clini-Dyne Rotational Therapy System CLP2000 Control Unit, CLM Series Mattress Operator’s Manual”, Rev. A, Oct. 2010, 8 pages.
- Gaymar Industries Inc., “EFF302 Alternating Pad Instructions”, Rev. A, Jan. 2010, 1 page.
- Gaymar Industries Inc., “Instructions for Use Sof Care Mattress Series”, Rev. A, May 2010, 12 pages.
- Gaymar Industries Inc., “O2 Zoned Multi-Functional Portable Rotation System P4000, P4001, C4000 Series control Unit, M4000 Series Mattress Operator’s Manual”, Rev. B, Oct. 2010, 12 pages.
- Gaymar Industries Inc., “Paradise Pump PAR 30 Contig F Alternating Pressure Pump Functional Check Instructions”, Rev. A, Apr. 2007, 1 page.
- Gaymar Industries Inc., “Paradise Pump Series Operator’s Manual”, Sep. 2005, 8 pages.
- Gaymar Industries Inc., “Plexus O2 Zoned Multi-Functional Portable Rotation System C4000 Series Control Unit, M4000 or M4001 Series Mattress Service Manual”, Rev. A, Oct. 2010, 40 pages.
- Gaymar Industries Inc., “Plexus Ref P102 Plexus Jr. Alternating Pressure System, Ref C102 Plexus Jr. APM Control Unit, Ref M100 Alternating Pressure Mattress Overlay Instructions for Use”, Rev. C, Apr. 2012, 20 pages.
- Gaymar Industries Inc., “Pressure Pedic Pressure Redistribution Mattress Instructions for Use”, Rev. B, Dec. 2009, 2 pages.
- Gaymar Industries Inc., “SC505 Sof Care Inflator Operating Instructions and Service Manual”, Rev. C, Oct. 2010, 8 pages.
- Gaymar Industries Inc., “Sof Care Bed Cushions Instructions for Use”, Sep. 1993, 2 pages.
- Gaymar Industries Inc., “Sof Matt Low Air Loss Mattress System Operator’s Manual/Service Manual”, Oct. 2010, 40 pages.
- Gaymar Industries Inc., “Symmetric Aire Mattress REF SYM3000 Series Instructions for Use”, Apr. 2012, 3 pages.
- Gaymar Industries, “Symmetric Aire Mattress Ref SYM3000 Series Service Document”, Rev. A, Jun. 2010, 2 pages.
- Hill-Rom, “300 Wound Surface Prevention and Treatment Surfaces Brochure”, Rev. 2, May 18, 2010, 2 pages.
- Hill-Rom, “Hill-Rom P500 Therapy Surface Product No. P005723 and P005787 User Manual”, Rev. 3, 2010, 54 pages.
- Hill-Rom, Synergy Air Elite Low Air Loss Therapy Brochure, Rev. 2, Dec. 30, 2008, 4 pages.
- Hill-Rom, “Synergy Air Elite Low Air Loss Therapy Webpage”, <https://homecare.hill-rom.com/en/durable-medical-equipment/therapy-mattresses/therapy-mattresses/synergy-air-elite-low-air-loss-therapy/>, 2019, 2 pages.
- Invacare Corporation, “MicroAir MA90 Series-Owner’s Operator and Maintenance Manual”, 2008, 28 pages.
- KAP Medical, “Digital Alternating Pressure True LAL System Brochure”, 2013, 2 pages.
- Medline, “Z-Flo Positioner/Covers by Molnlycke”, <http://www.medline.com/product/Z-Flo-Positioners-by-Sundance-Enterprises-Inc/Z05-PF70265>, 2016, 1 page.
- Plexus Medical, “O2 Zoned C4000 Portable Rotation System; CareMedx C5000 Multi-Zoned Low Air Loss Therapy System Service Manual”, published at least prior to Sep. 2018, 58 pages.
- Plexus Medical, “Plexus C1000D Series Control Unit Service Manual”, published at least prior to Sep. 2018, 20 pages.
- Plexus Medical, “Plexus P1500 Air Express LAL System Service Manual”, published at least prior to Sep. 2018, 17 pages.
- Sage Products, “Pressure Injury and Safe Patient Handling Solutions—Prevalon Mobile Air Transfer Systems; Prevalon Turn & Position Systems; Prevalon Heel Protectors; Prevalon Seated Positioning System Brochure”, 2017, 20 pages.
- Sage Products, “Prevalon Air Pump Brochure”, 2017, 1 page.
- Sage Products, “Prevalon AirTap Patient Repositioning System Operator’s Manual”, 2016, 10 pages.
- Sage Products, “Prevalon Standard Turn and Position System Instructions for Use”, 2016, 1 page.
- Sage Products, “Prevalon Turn and Position System 2.0 Instructions for Use”, 2016, 1 page.
- Sage Products, “Sage Product Catalog—Pressure Injury Prevention and Safe Patient Handling”, 2018, 4 pages.
- Stryker Medical, “Arise 1000 EX Low Air-Loss Bariatric Surface Specification Sheet”, Rev. B, 2008, 2 pages.
- Stryker Medical, “Arise 1000EX Low Air Loss Therapy Mattress Model 2236 Operations/Maintenance Manual”, Rev. B, May 2009, 30 pages.
- Stryker Medical, “ComfortGel SE Support Surface Ref 1805 Operations Manual”, Rev. C, Sep. 2016, 18 pages.
- Stryker Medical, “ComfortGel Support Surface Ref 2850 Operations Manual”, Rev. A, Aug. 2017, 22 pages.
- Stryker Medical, “ComfortGel Support Surface Specification Sheet”, Rev. E.6, Dec. 2011, 2 pages.
- Stryker Medical, “EOLE / EOLE DC Pump Ref 2870, Ref 2871 Service Manual”, Oct. 2017, 16 pages.
- Stryker Medical, “EOLE DC Powered Support Surface Ref 2871 Operations/Maintenance Manual”, Dec. 2017, 288 pages.
- Stryker Medical, “EOLE Powered Support Surface Ref 2870 Operations/Maintenance Manual”, Dec. 2017, 288 pages.
- Stryker Medical, “IsoAir Ref 2940 Service Manual”, Rev. 1.0, Nov. 2016, 144 pages.
- Stryker Medical, “IsoFlex LAL Support Surface Specification Sheet”, Rev. D.3, 2016, 2 pages.
- Stryker Medical, “Isoflex Pressure Management Mattress Instructions for Use”, Rev. A, Jun. 2010, 2 pages.
- Stryker Medical, “IsoFlex SE Support Surface Ref 1806 Operations Manual”, Rev. C, Sep. 2016, 20 pages.
- Stryker Medical, “IsoGel Air Support Surface Ref 2860 Operations Manual”, Rev. F, May 2015, 25 pages.
- Stryker Medical, “IsoGel Support Surface Dimensional Gel Technology Specification Sheet”, Dec. 2013, 2 pages.
- Stryker Medical, “Isolibrium Support Surface Ref 2971 Operations/Maintenance Manual”, Rev. B, Oct. 2014, 202 pages.
- Stryker Medical, “Isolibrium Support Surface Ref 2971 Operations/Maintenance Manual”, Rev. C, May 2014, 200 pages.
- Stryker Medical, “Isolibrium Support Surface Specification Sheet”, Rev. E.4, Nov. 2013, 2 pages.
- Stryker Medical, “Isolibrium Support Surface Version 4.0, Ref 2971, Ref 2972 Maintenance Manual”, Rev. B, May 2017, 88 pages.
- Stryker Medical, “Isolibrium Support Surface Version 4.0, Ref 2971, Ref 2972 Maintenance Manual”, Rev. C-C.2, Jul. 2017, 88 pages.
- Stryker Medical, “P100/Sof Care Pump Ref 2880, Ref 2890 Service Manual”, Oct. 2017, 8 pages.

(56)

References Cited

OTHER PUBLICATIONS

Stryker Medical, "Position Pro Therapy Mattress Model 2920 Operations/Maintenance Manual", Rev. A, Feb. 2007, 55 pages.

Stryker Medical, "PositionPro Patient Repositioning Support Surface-Standalone with Pendant or Integrated with FL27 InTouch CC Model Beds Ref 2920 Maintenance Manual", Rev. A, Oct. 2016, 56 pages.

Stryker Medical, "PositionPro Patient Repositioning Support Surface-Standalone with Pendant or Integrated with FL27 InTouch CC Model Beds Ref 2920 Maintenance Manual", Rev. G, Oct. 2016, 42 pages.

Stryker Medical, "Pressure Management—Dynamic Mattress System 2500 Operations/Maintenance Manual", published at least prior to Sep. 2018, 17 pages.

Stryker Medical, "Pressure Management—Dynamic Mattress System 2500 Operations/Maintenance Manual", published at least prior to Sep. 2018, 23 pages.

Stryker Medical, "ProForm Non-Powered Support Surface Model 2710 Operations/Maintenance Manual", Rev. G, Sep. 14, 2015, 134 pages.

Stryker Medical, "Save Simply Brochure", 2018, 2 pages.

Stryker Medical, "Sof Care Chair Cushion Ref 2770-100-000 Operations Manual", Rev. D, Apr. 2016, 1 page.

Stryker Medical, "Sof Care DuoGard Overlay Brochure", 2017, 2 pages.

Stryker Medical, "SofCare Healthcare Boot, Ref 2760-100-000, Ref 2760-200-000, Ref 2760-300-000 Operations Manual", Rev. C, Mar. 2016, 2 pages.

Stryker Medical, "SofCare HeelCare Boot Series Specification Sheet", Rev. B.3, Aug. 2011, 2 pages.

Stryker Medical, SofCare Stretcher Overlay Ref 2780-400-000, Ref 2780-500-000 Operations Manual, Rev. B, Dec. 2014, 2 pages.

Stryker Medical, "SPR Plus Overlay Ref 2790-100-000 Operations Manual", Rev. B, Dec. 2014, 2 pages.

Stryker Medical, "Stryker Air I, Stryker Air II Low Air Loss Therapy Mattress (LAL), Model 2236 Operations/Maintenance Manual", Rev. B, May 2009, 30 pages.

Stryker Medical, "Stryker Air Pump REF 2861 Operation/Maintenance Manual", Rev. 2.0, Jun. 2016, 24 pages.

Stryker Medical, "Stryker Air Pump Ref 2861 Service Manual", Rev. 2.0, Jun. 2016, 58 pages.

Stryker Medical, "Stryker IsoAir Ref 2940" Operation/Maintenance Manual", Rev. 4.00, Dec. 2015, 52 pages.

Stryker Medical, "Ultra Comfort SE Support Surface Ref. 1703; Ref. 1704 Operations Manual", Rev. D, May 2017, 40 pages.

Stryker Medical, "XPRT Pulmonary Therapy & Wound Care Mattress Model 2950 Operations/Maintenance Manual", Rev. C, Aug. 2007, 114 pages.

Stryker Medical, "XPRT Therapeutic Support Surface Ref 2950 Operations/Maintenance Manual", Rev. B, Jun. 2012, 468 pages.

Stryker Medical, XPRT Therapy Mattress Model 2950 Operations Manual, Rev. A, Jul. 2006, 98 pages.

Stryker Medical, "XPRT Therapy Mattress Model 2950 Operations/Maintenance Manual", Rev. A, May 2006, 98 pages.

Stryker Medical, "XPRT Therapy Mattress Model 2950 Operations/Maintenance Manual", Rev. H, Jun. 2006, 98 pages.

Stryker Medical, "DuoGard Overlay Ref 2780-300-000 Operations Manual", Rev. B, Dec. 2014, 1 page.

Design U.S. Appl. No. 29/664,890, filed Sep. 28, 2018.

Design U.S. Appl. No. 29/664,888, filed Sep. 28, 2018.

Design U.S. Appl. No. 29/664,886, filed Sep. 28, 2018.

* cited by examiner

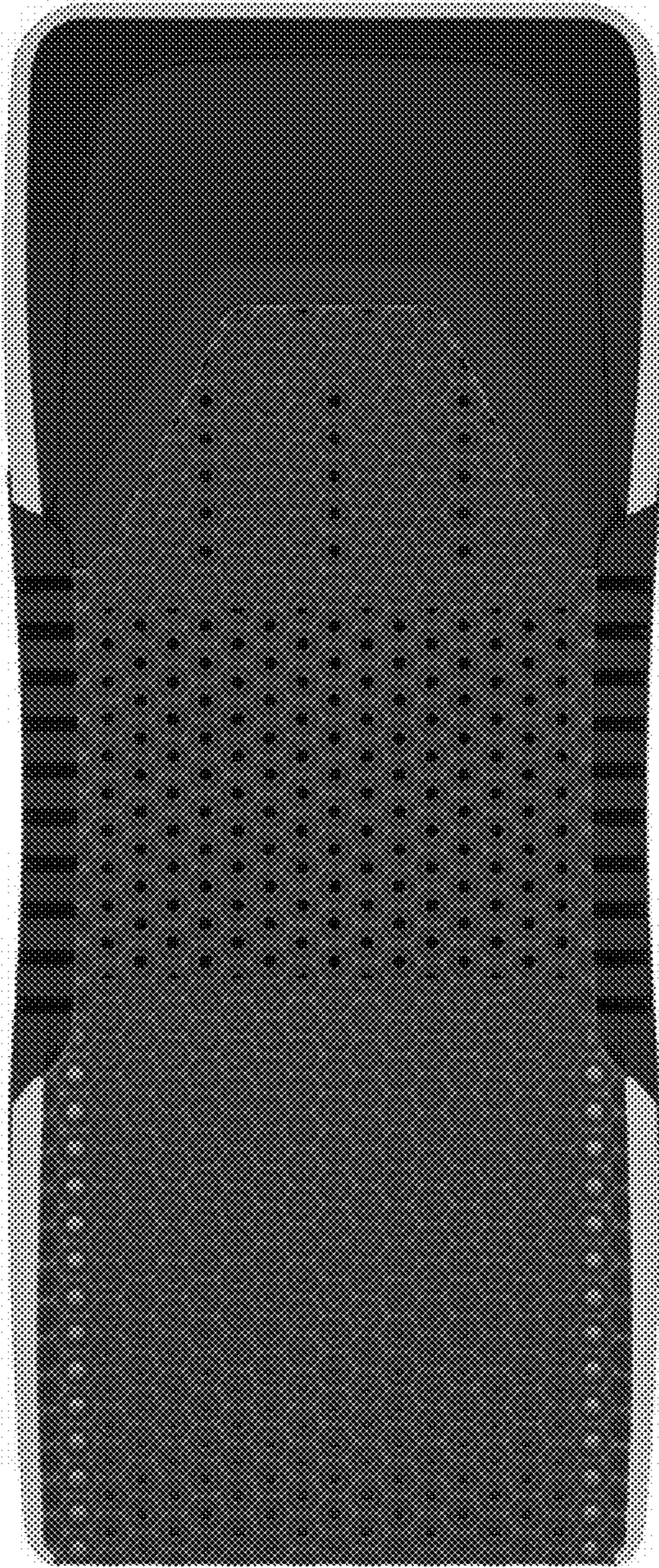

FIG. 1

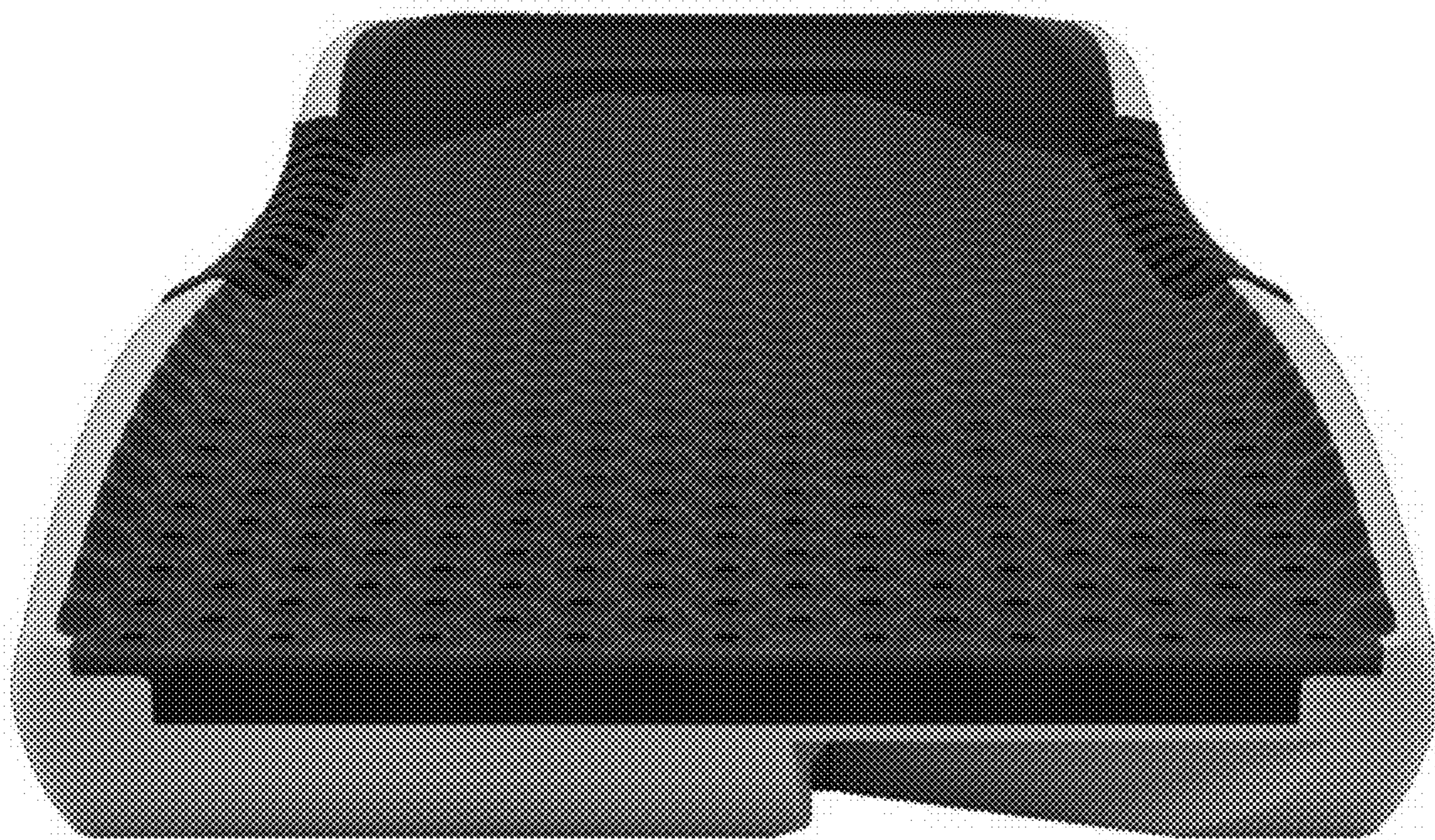

FIG. 2

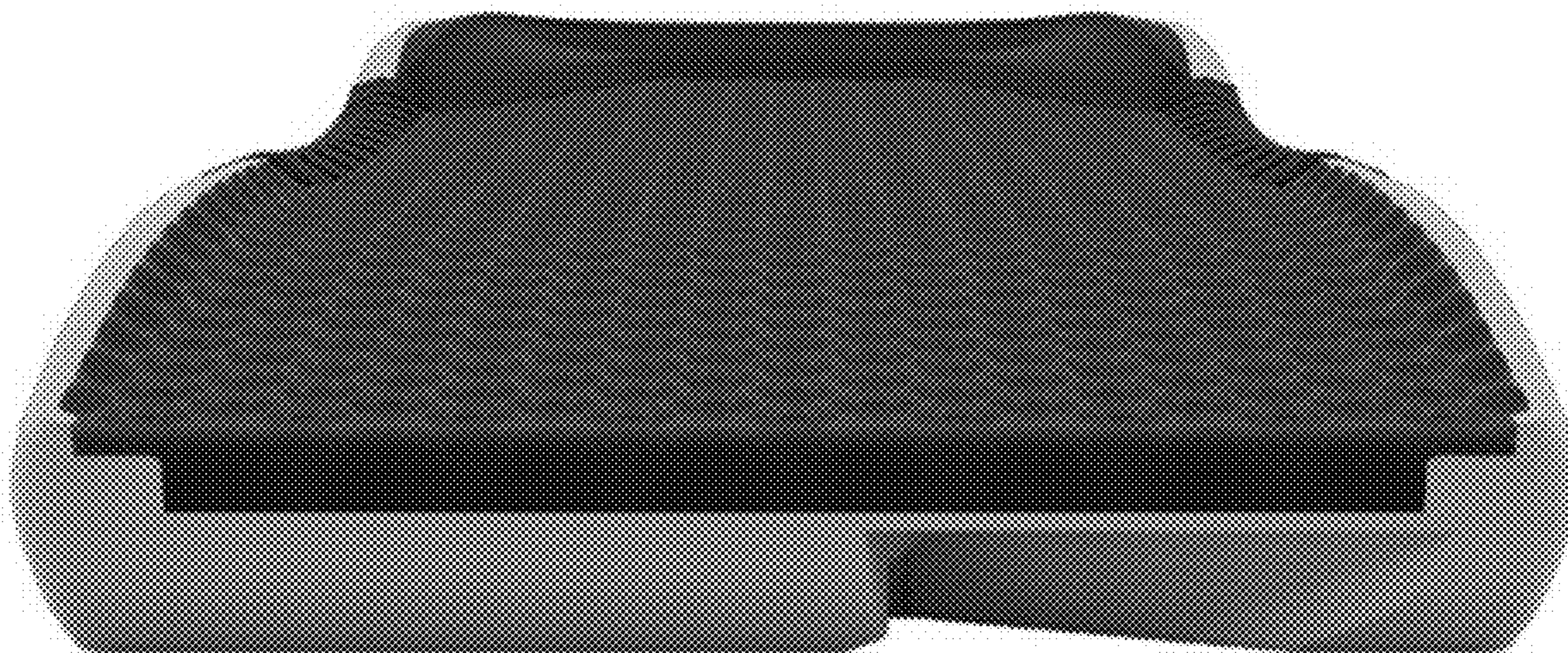

FIG. 3



FIG. 4



FIG. 5



FIG. 6

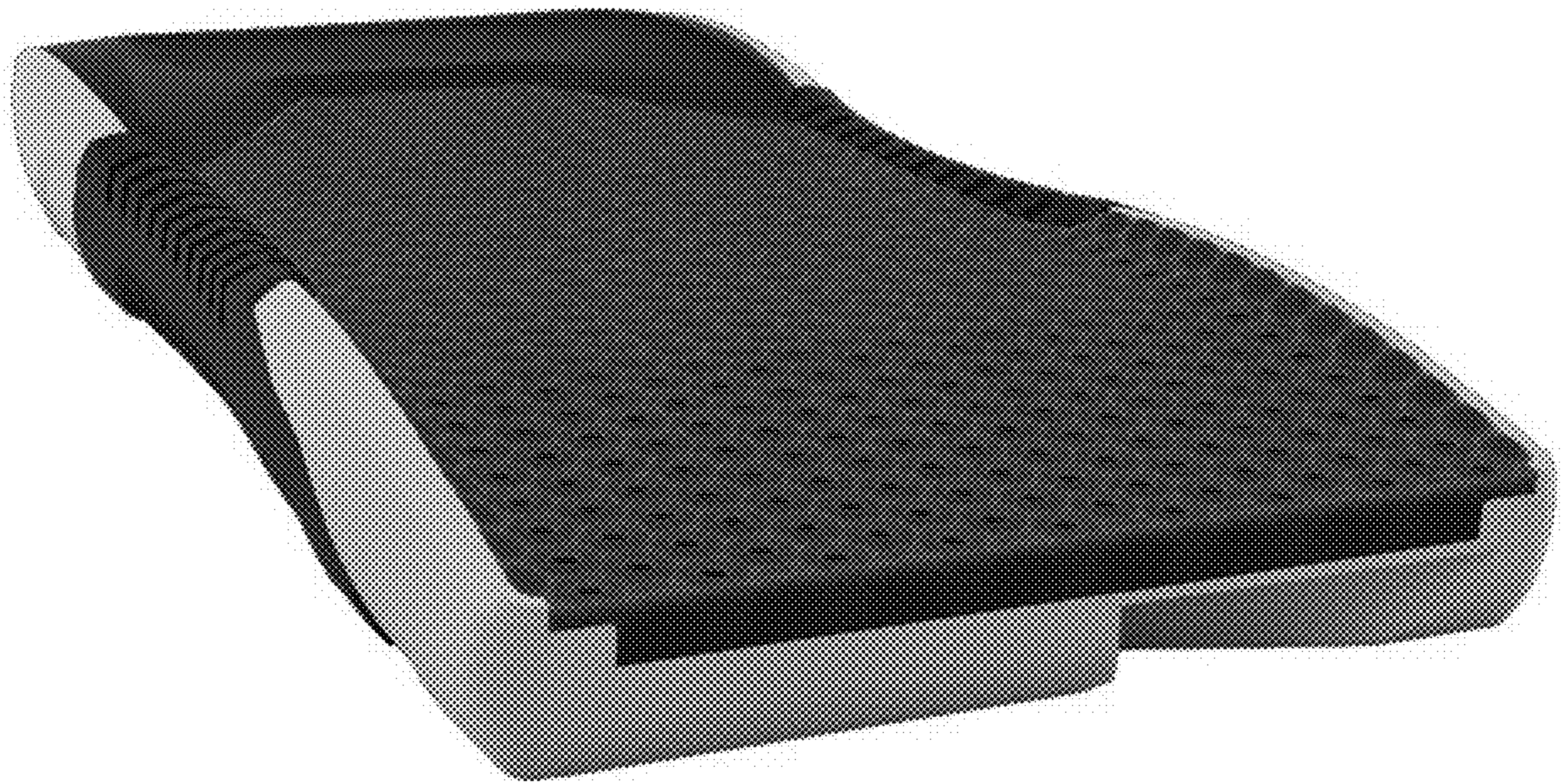

FIG. 7



FIG. 8

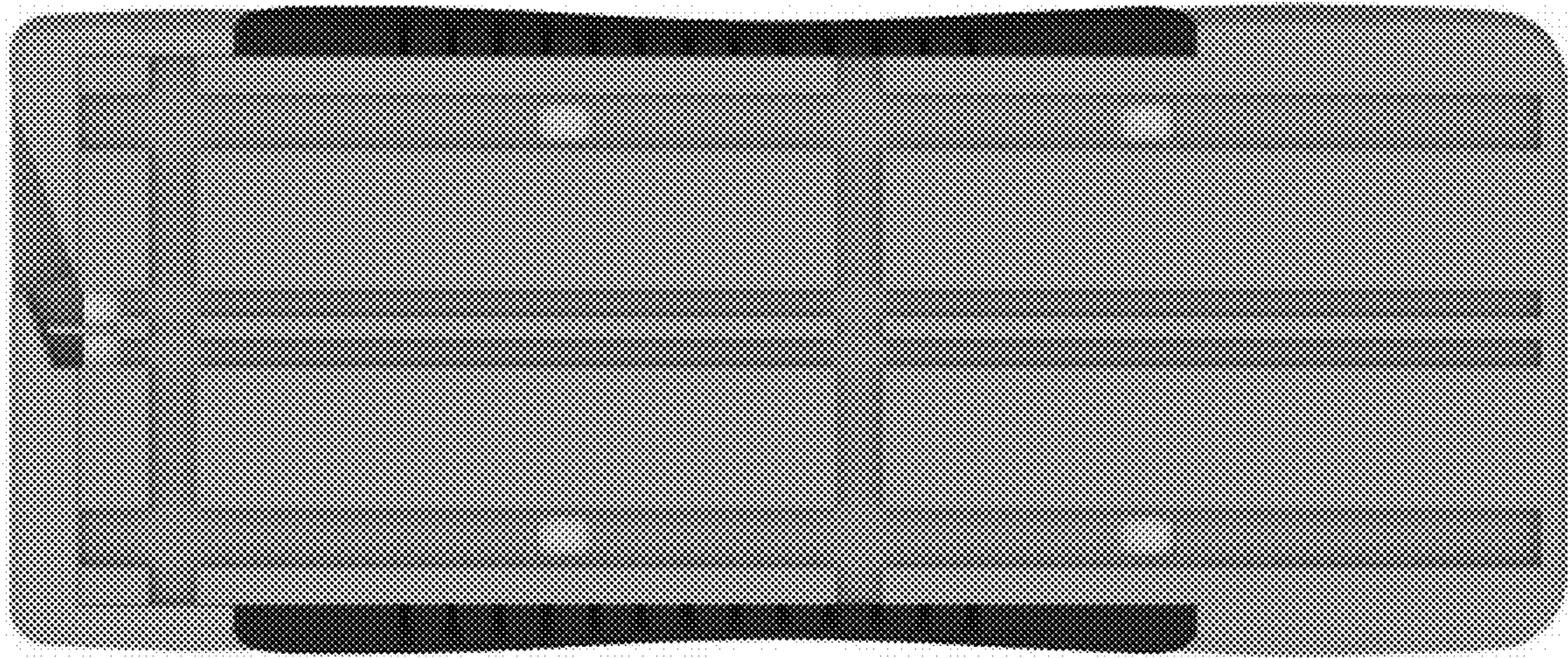

FIG. 9



FIG. 10

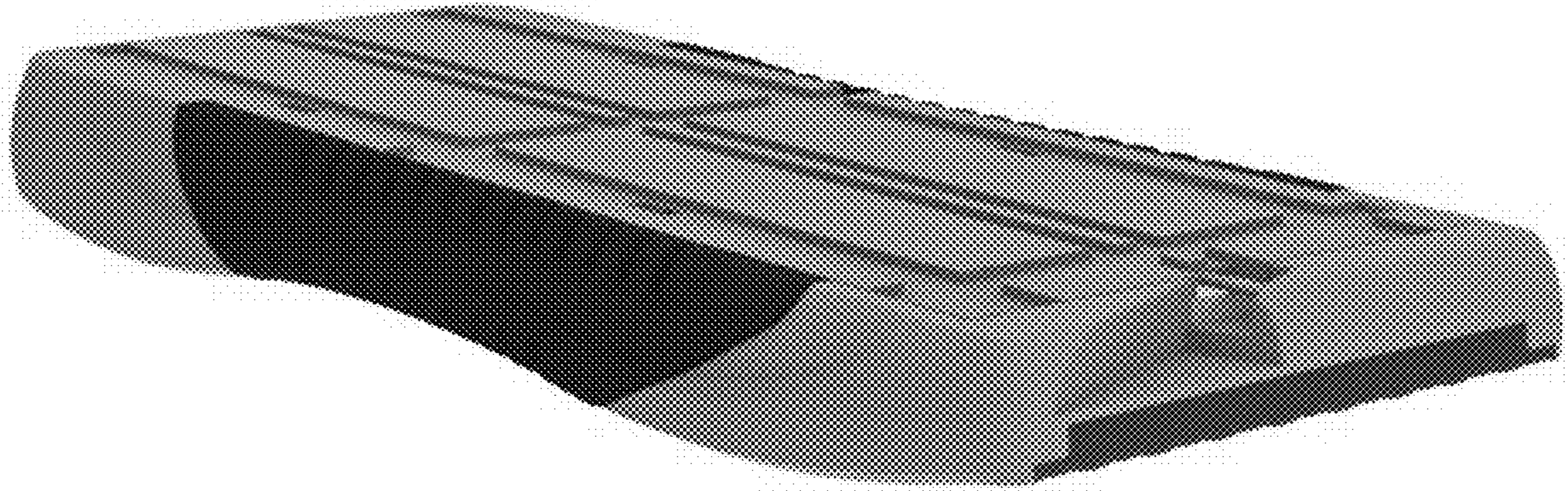

FIG. 11

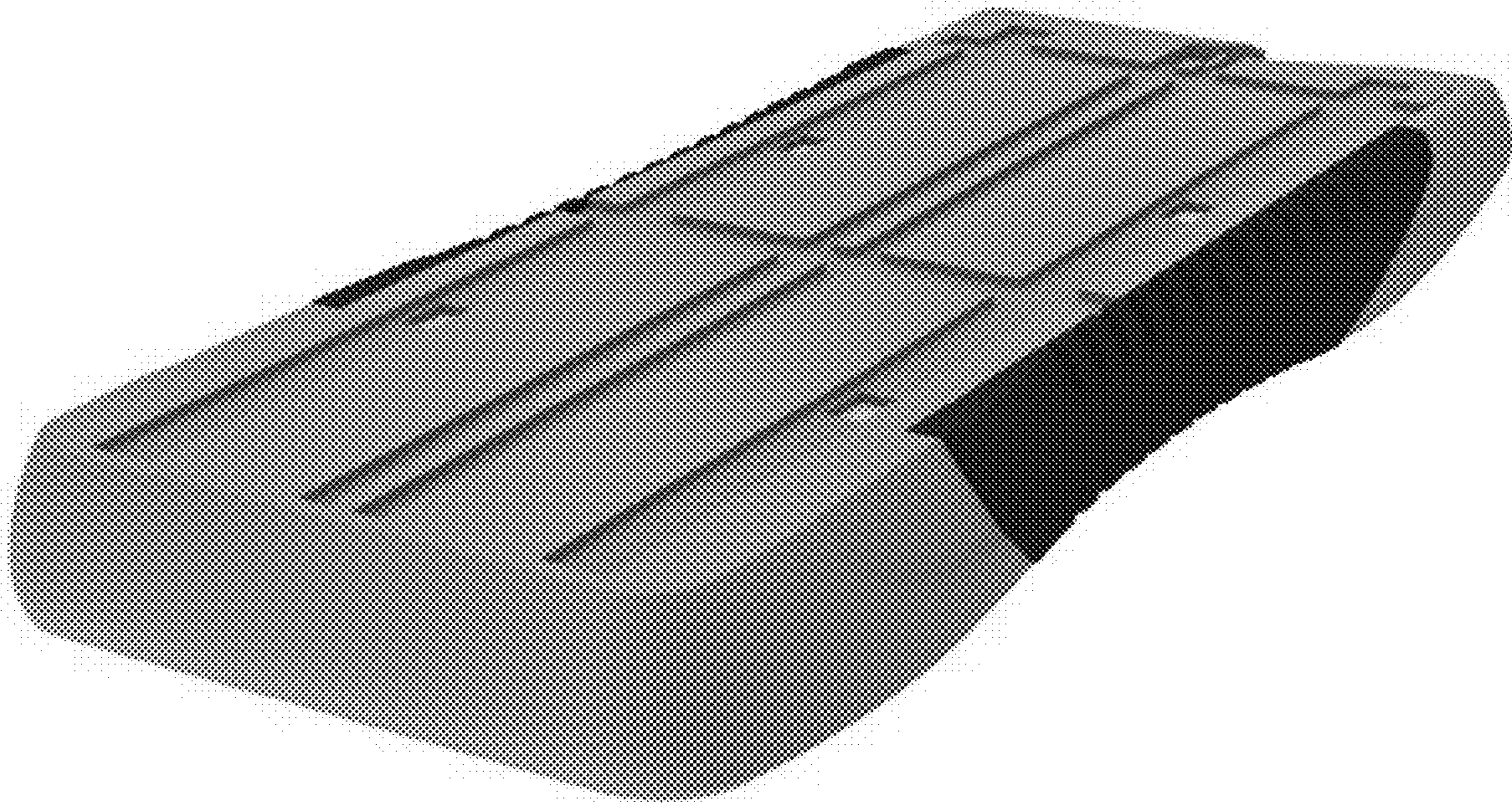

FIG. 12

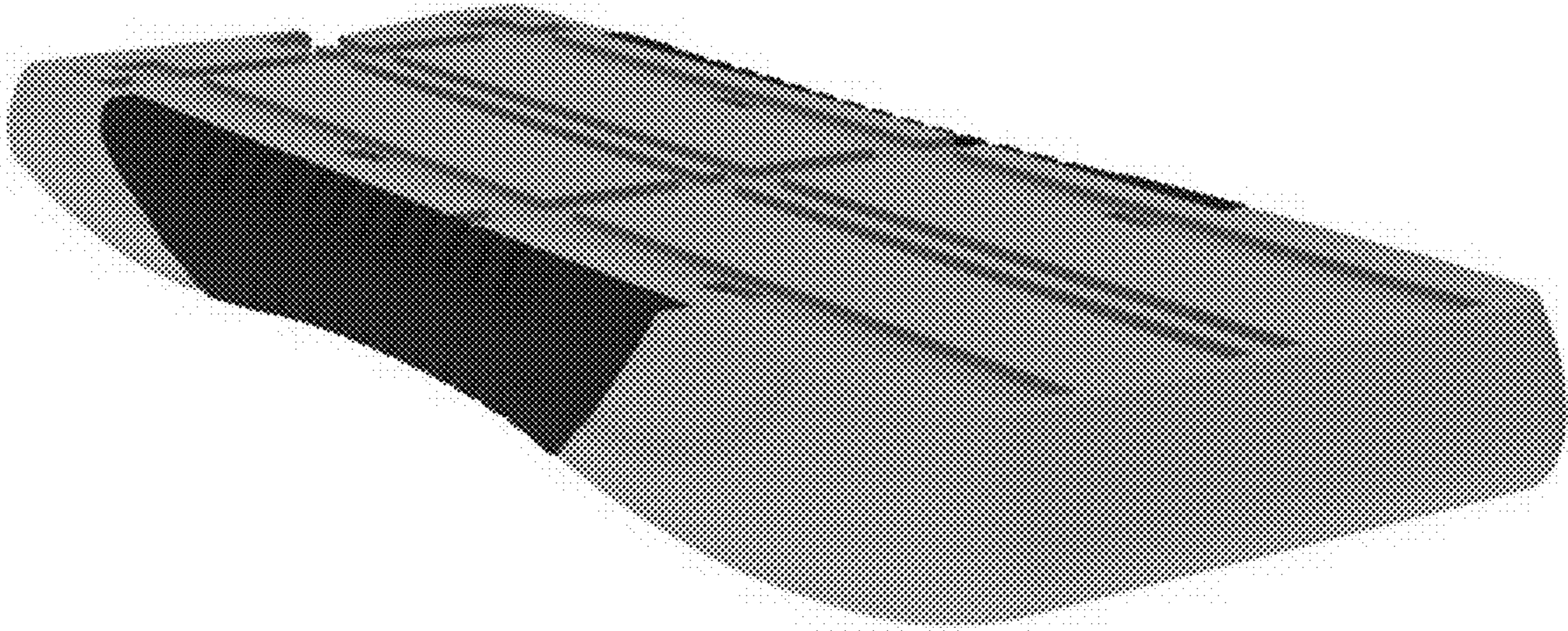

FIG. 13



FIG. 14

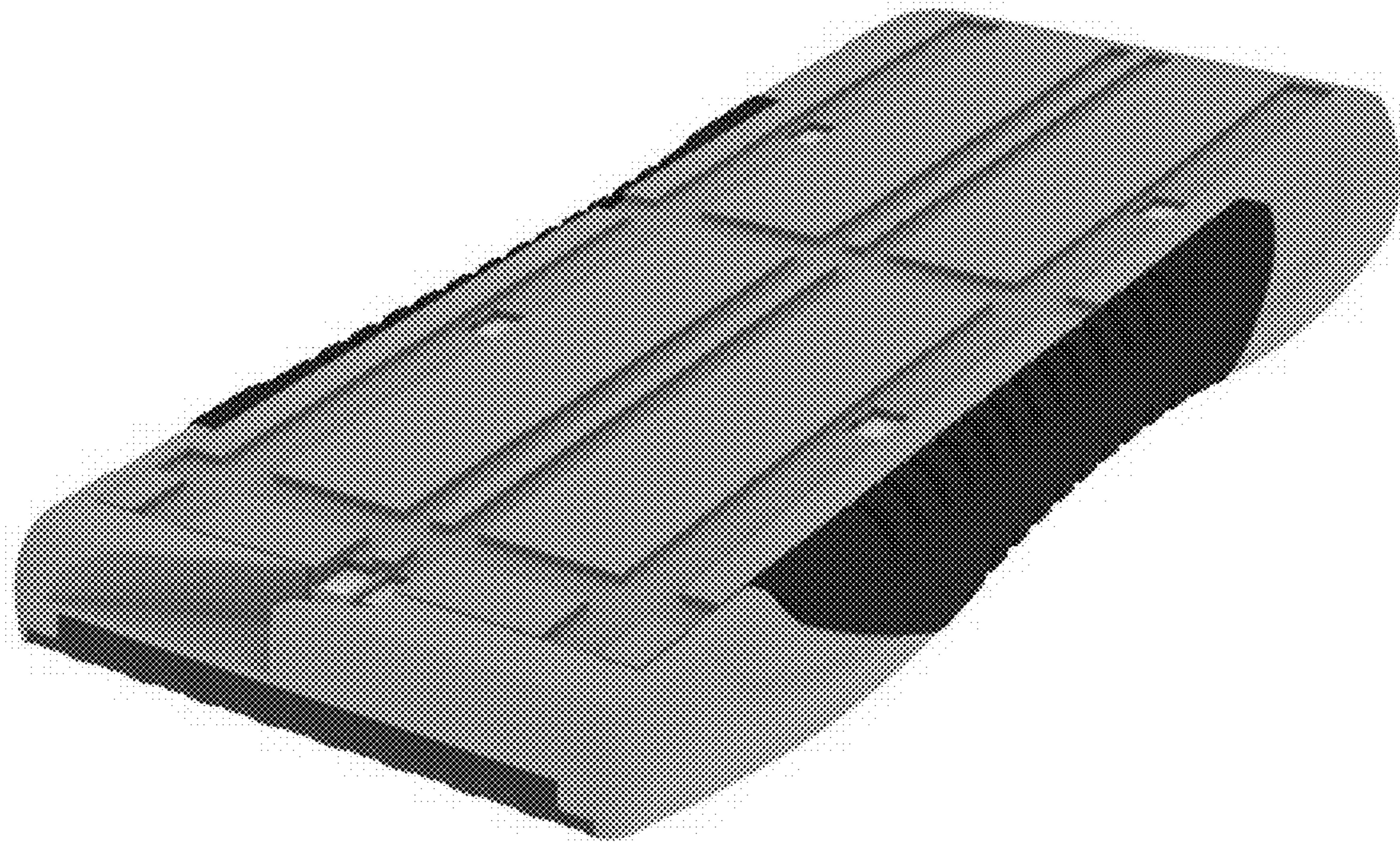

FIG. 15