



US00D877683S

(12) **United States Design Patent**  
**Shirokikh**

(10) **Patent No.:** **US D877,683 S**  
(45) **Date of Patent:** **\*\* Mar. 10, 2020**

(54) **MOTOR BOAT**

(71) Applicant: **Sergey Vladimirovich Shirokikh,**  
Kaliningrad (RU)

(72) Inventor: **Sergey Vladimirovich Shirokikh,**  
Kaliningrad (RU)

(\*\*) Term: **15 Years**

(21) Appl. No.: **35/505,519**

(22) Filed: **Jul. 2, 2018**

(80) **Hague Agreement Data**

Int. Filing Date: **Jul. 2, 2018**  
Int. Reg. No.: **DM/102300**  
Int. Reg. Date: **Jul. 2, 2018**  
Int. Reg. Pub. Date: **Aug. 24, 2018**

(30) **Foreign Application Priority Data**

Feb. 13, 2018 (RU) ..... 2018500720

(51) **LOC (12) Cl.** ..... **12-06**

(52) **U.S. Cl.**  
USPC ..... **D12/300**

(58) **Field of Classification Search**  
USPC ..... D12/300, 302, 303, 304, 307, 310-314,  
D12/316, 317; D21/542, 543  
CPC ..... B63B 17/00; B63B 17/02; B63B 35/81;  
B63B 35/816; B62B 21/04  
See application file for complete search history.

(56) **References Cited**

**U.S. PATENT DOCUMENTS**

D294,343 S \* 2/1988 Scarboro ..... D12/314  
D429,682 S \* 8/2000 Garland ..... D12/300  
D475,338 S \* 6/2003 Zurn ..... D12/300

D506,430 S \* 6/2005 de Rover ..... D12/300  
6,994,049 B1 \* 2/2006 Schulz ..... B63B 1/20  
114/274  
D587,641 S \* 3/2009 Bouckaert ..... D12/300  
D700,127 S \* 2/2014 Fuller, IV ..... D12/300  
9,003,997 B2 \* 4/2015 Gratz ..... B63B 17/00  
114/362  
D770,963 S \* 11/2016 Demaria ..... D12/300  
D817,848 S \* 5/2018 Mattila ..... D12/300  
D818,417 S \* 5/2018 Mattila ..... D12/300  
D826,833 S \* 8/2018 Mattila ..... D12/300  
D826,834 S \* 8/2018 Mattila ..... D12/300  
D826,836 S \* 8/2018 Mattila ..... D12/300  
D826,837 S \* 8/2018 Mattila ..... D12/300  
D828,276 S \* 9/2018 Mattila ..... D12/300  
D828,277 S \* 9/2018 Mattila ..... D12/300  
D828,278 S \* 9/2018 Mattila ..... D12/300  
D840,909 S \* 2/2019 Mattila ..... D12/300  
D840,910 S \* 2/2019 Mattila ..... D12/300  
D848,347 S \* 5/2019 Mattila ..... D12/300

\* cited by examiner

*Primary Examiner* — Darlington Ly

(74) *Attorney, Agent, or Firm* — Nixon & Vanderhye PC

(57) **CLAIM**

The ornamental design for a motor boat, as shown and described.

**DESCRIPTION**

Fig. 1.1 is a first perspective view of a motor boat according to our new design;  
Fig. 1.2 is a rear elevation view thereof;  
Fig. 1.3 is a front elevation view thereof;  
Fig. 1.4 is an enlarged view of a portion of an inside thereof;  
Fig. 1.5 is a right side view thereof;  
Fig. 1.6 is a top plan view thereof; and  
Fig. 1.7 is a second perspective view thereof.  
The broken lines depict an outboard motor for reference and form no part of the claimed design.

**1 Claim, 7 Drawing Sheets**

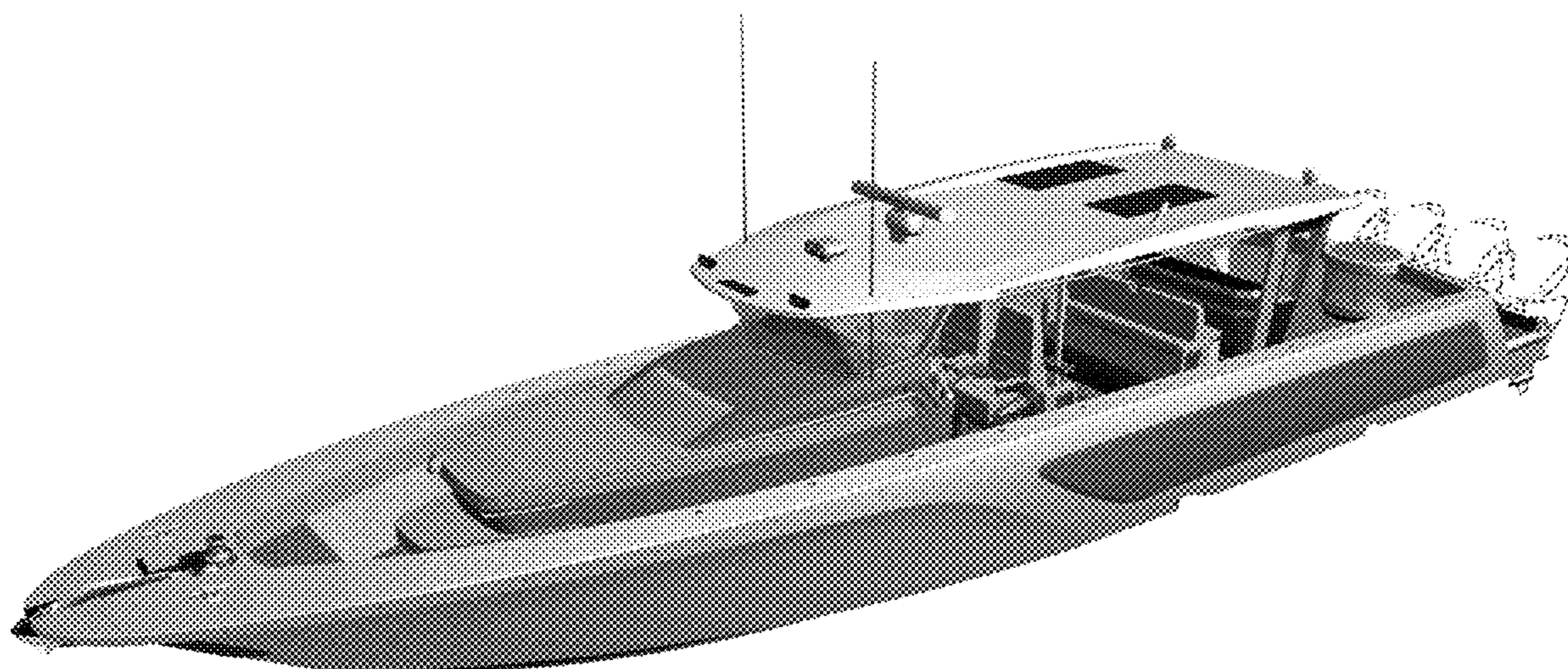

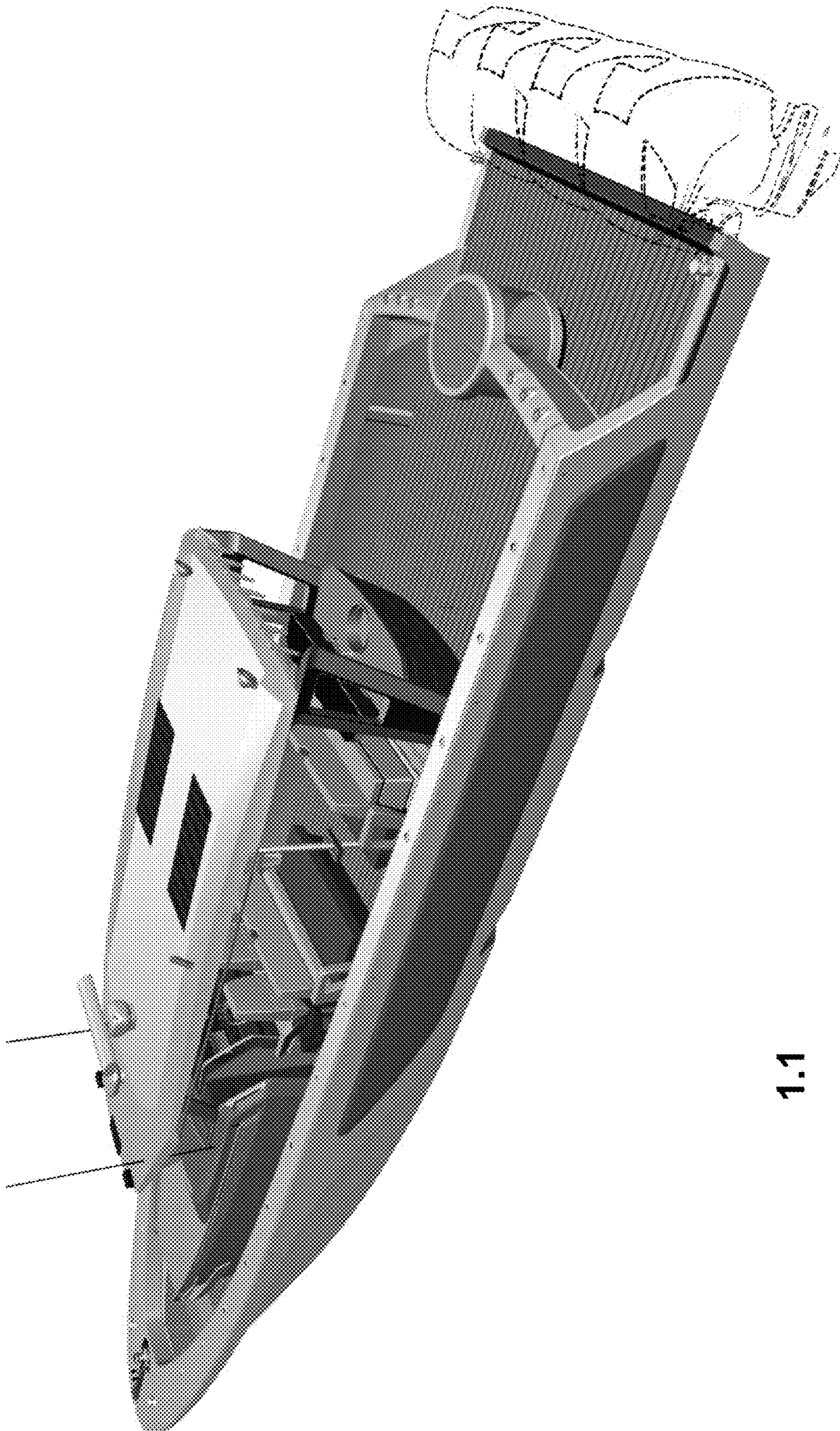

1.1

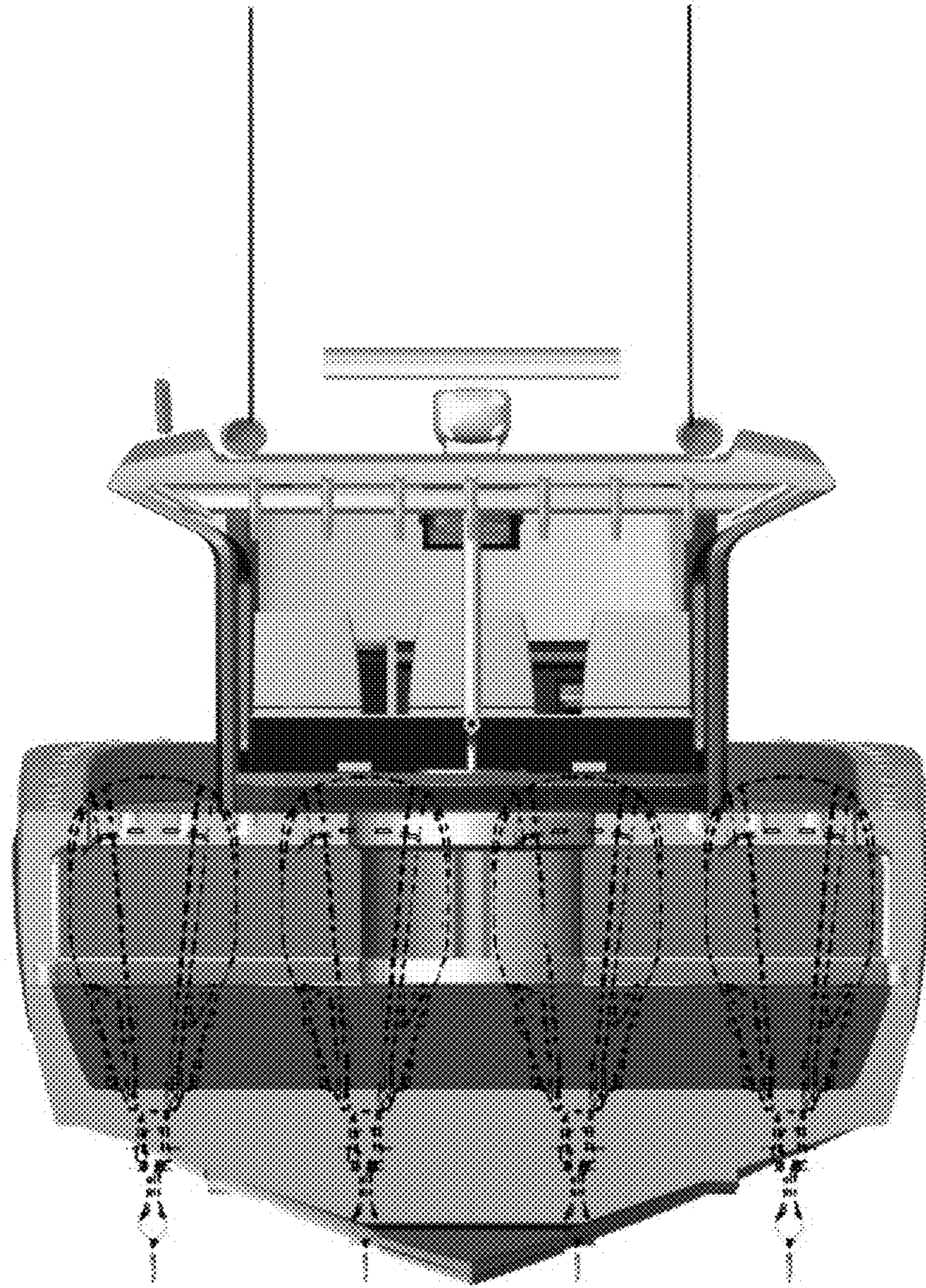

1.2

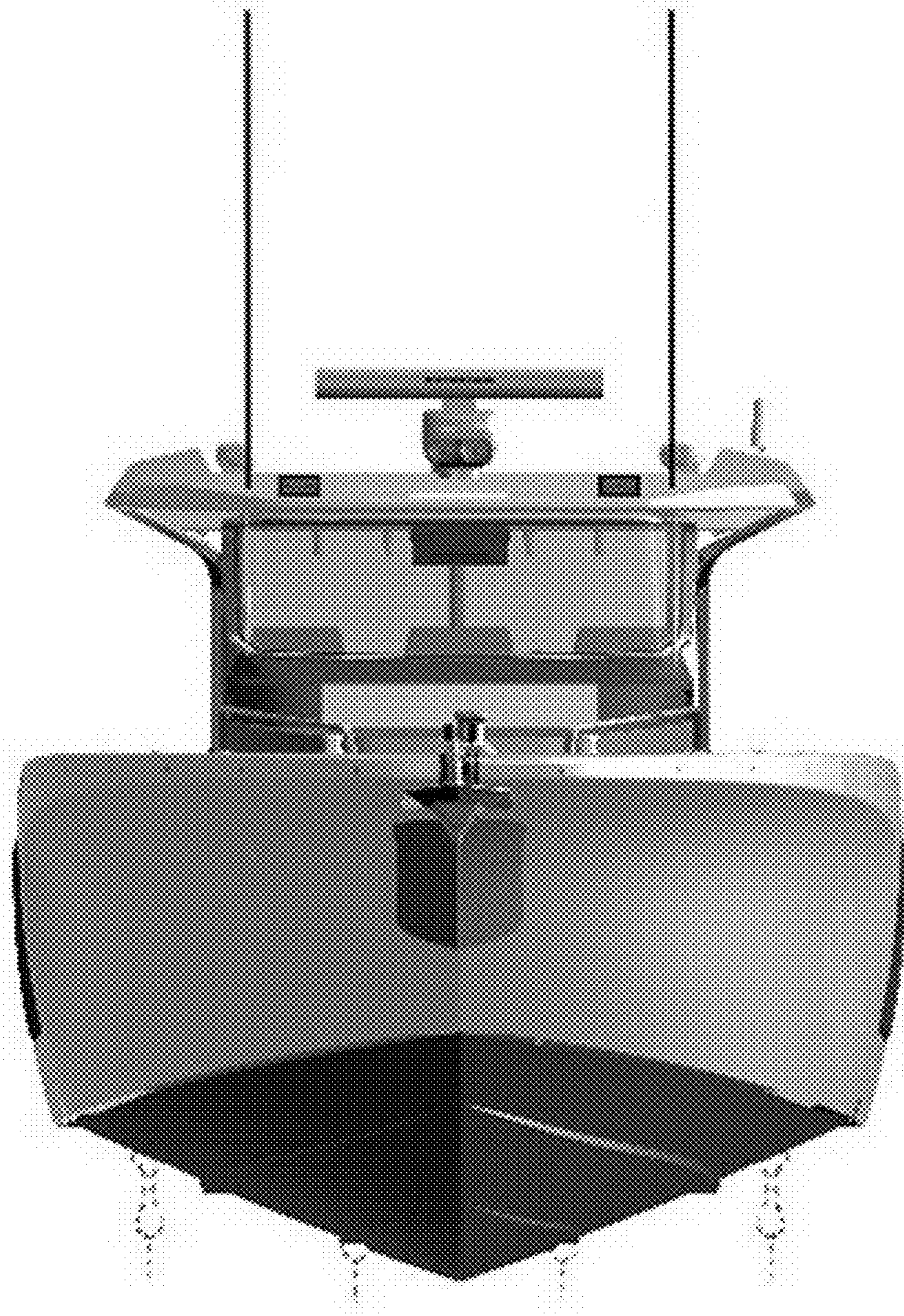

1.3



1.4

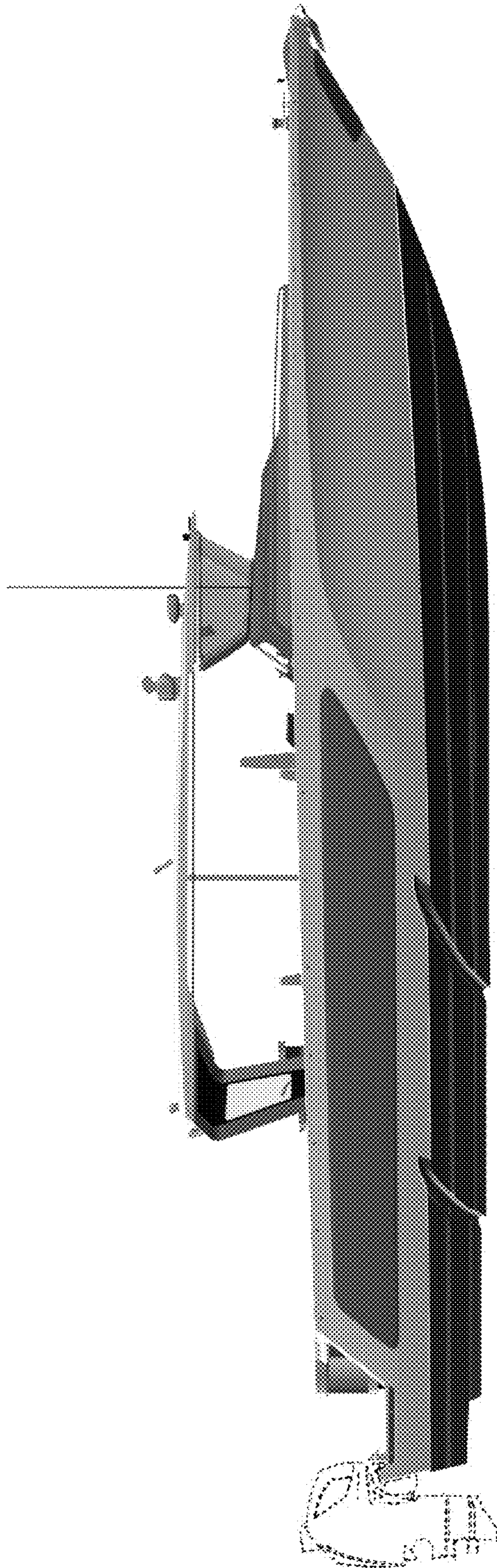

1.5

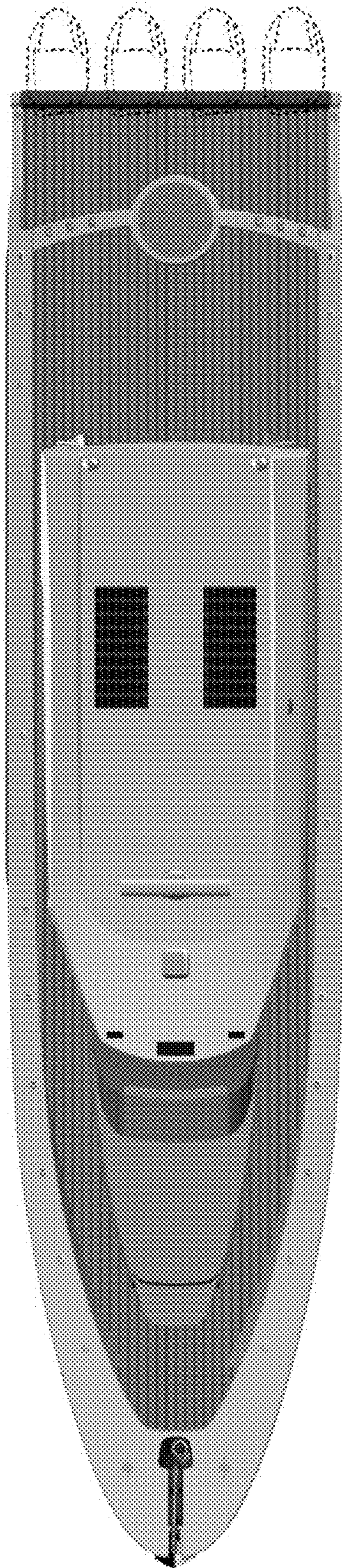

1.6

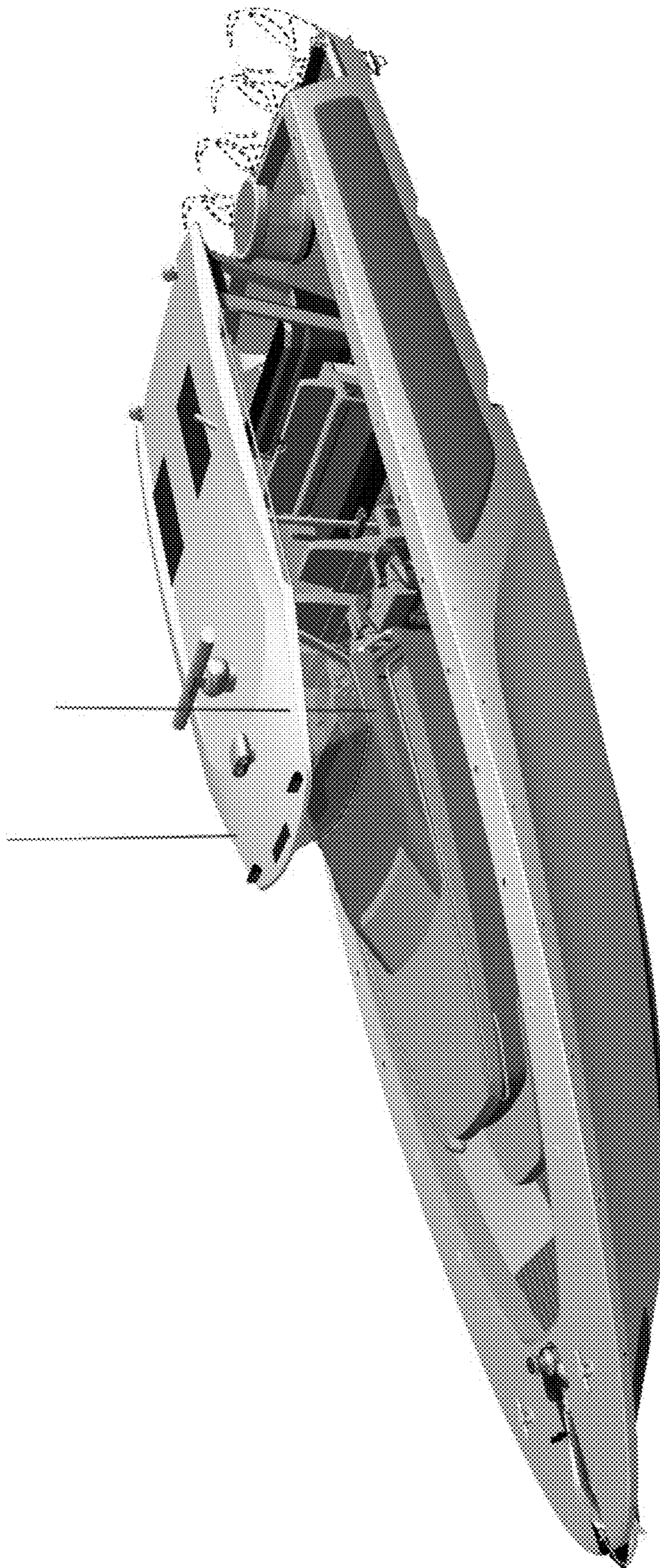

1.7