



US00D877353S

(12) **United States Design Patent**
Ito

(10) **Patent No.:** **US D877,353 S**
(45) **Date of Patent:** **** Mar. 3, 2020**

(54) **COMBINED CELL TRANSFER NOZZLE AND PIPETTE TIP FOR CELL CLUSTERING**

(71) Applicant: **Saburo Ito**, Shizuoka-ken (JP)

(72) Inventor: **Saburo Ito**, Shizuoka-ken (JP)

(73) Assignee: **YAMAHA HATSUDOKI KABUSHIKI KAISHA** (JP)

(**) Term: **15 Years**

(21) Appl. No.: **29/665,180**

(22) Filed: **Oct. 1, 2018**

Related U.S. Application Data

(62) Division of application No. 29/546,884, filed on Nov. 27, 2015, now Pat. No. Des. 846,143.

(30) **Foreign Application Priority Data**

May 28, 2015 (JP) 2015-011787

May 28, 2015 (JP) 2015-011788

(51) **LOC (12) Cl.** **24-02**

(52) **U.S. Cl.**
USPC **D24/222**

(58) **Field of Classification Search**

USPC D24/107, 108, 113, 114, 121, 133, 184,
D24/186, 216, 222, 224, 225, 226, 227,
D24/228, 229, 230, 231, 233

(Continued)

(56) **References Cited**

U.S. PATENT DOCUMENTS

D257,567 S 11/1980 Peacock D24/114

D357,324 S * 4/1995 Bartal D24/222

(Continued)

Primary Examiner — Vy N Koenig

(74) *Attorney, Agent, or Firm* — Ostrolenk Faber LLP

(57) **CLAIM**

The ornamental design for a combined cell transfer nozzle and pipette tip for cell clustering, as shown and described.

DESCRIPTION

FIG. 1 is a front perspective view of a combined cell transfer nozzle and pipette tip for cell clustering showing a first embodiment of my new design;

FIG. 2 is a side view thereof, wherein the view from every lateral side thereof is identical;

FIG. 3 is a front end view thereof;

FIG. 4 is a rear end view thereof;

FIG. 5 is a cross-sectional view thereof along line 5-5 in FIG. 2;

FIG. 6 is an enlarged fragmentary side view thereof of fragment 6-6 in FIG. 2, wherein the view from every lateral side thereof is identical and the jagged line indicates the rear end of the fragment;

FIG. 7 is an end view of fragment 6-6 in FIG. 2;

FIG. 8 is a front perspective view of fragment 6-6 in FIG. 2 and the jagged line indicates the rear end of the fragment and the jagged line indicates the rear end of the fragment;

FIG. 9 is a perspective view of the first embodiment showing an alternate condition of the first embodiment of my new design;

FIG. 10 is a cross-sectional view thereof along line 10-10 in FIG. 9;

FIG. 11 is an enlarged fragmentary front perspective view of fragment 11-11 in the same alternate configuration as in FIG. 9 and the jagged line indicates the rear end of the fragment;

FIG. 12 is a front perspective view of a combined cell transfer nozzle and pipette tip for cell clustering showing a second embodiment of my new design;

FIG. 13 is a side view thereof, wherein the view from every side thereof is identical;

FIG. 14 is a front end view thereof;

FIG. 15 is a rear end view thereof;

FIG. 16 is a cross-sectional view thereof along line 16-16 in FIG. 13;

FIG. 17 is an enlarged fragmentary side view thereof of fragment 17-17 in FIG. 13, wherein the view from every side thereof is identical and the jagged line indicates the rear end of the fragment;

FIG. 18 is an end view of the fragment in FIG. 17;

FIG. 19 is a front perspective view of the fragment in FIG. 17 and the jagged line indicates the rear end of the fragment;

FIG. 20 is a front perspective view of the second embodiment showing an alternate condition of the second embodiment of my new design;

FIG. 21 is a cross-sectional view thereof along line 21-21 in FIG. 20; and,

(Continued)

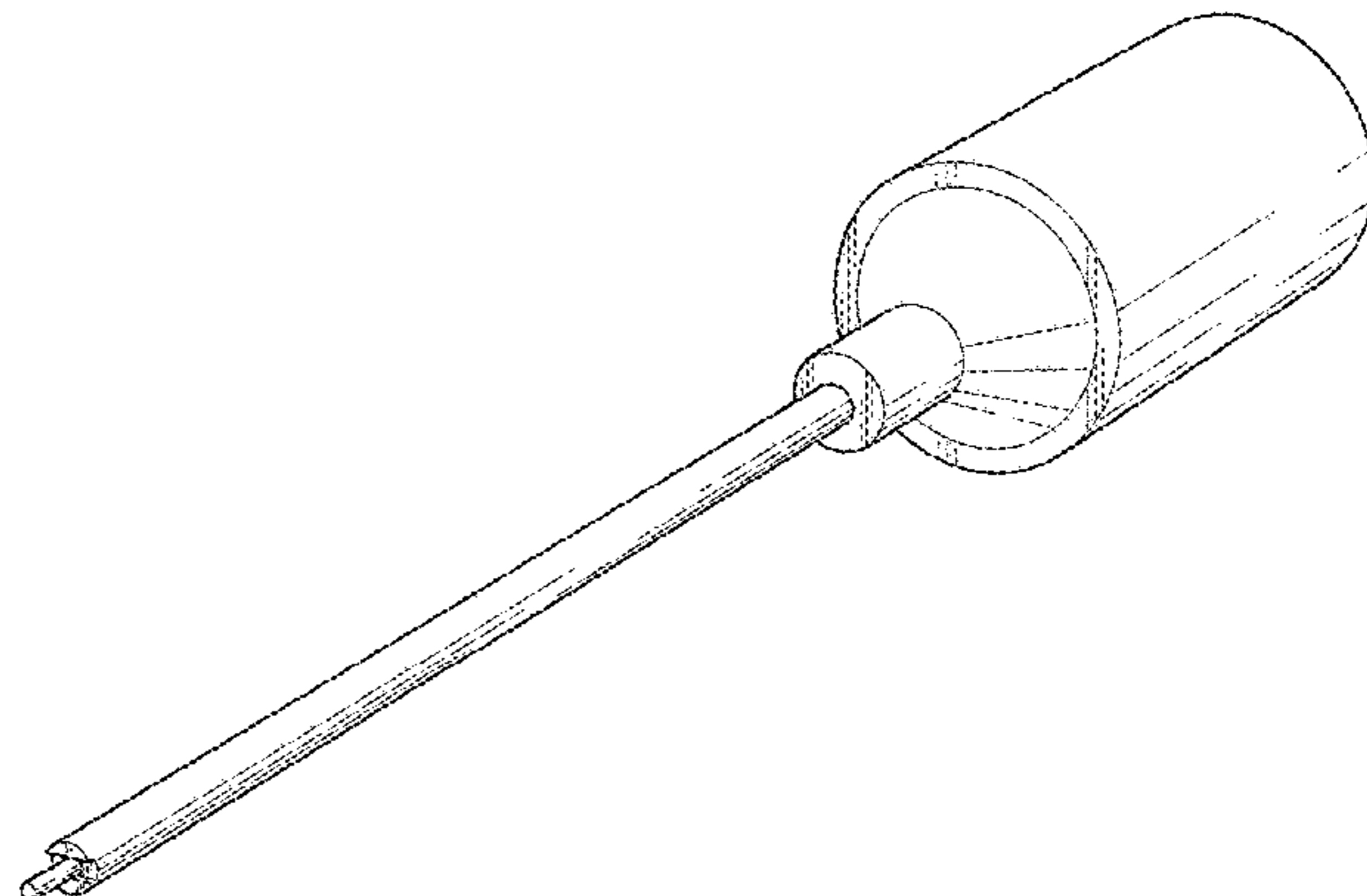
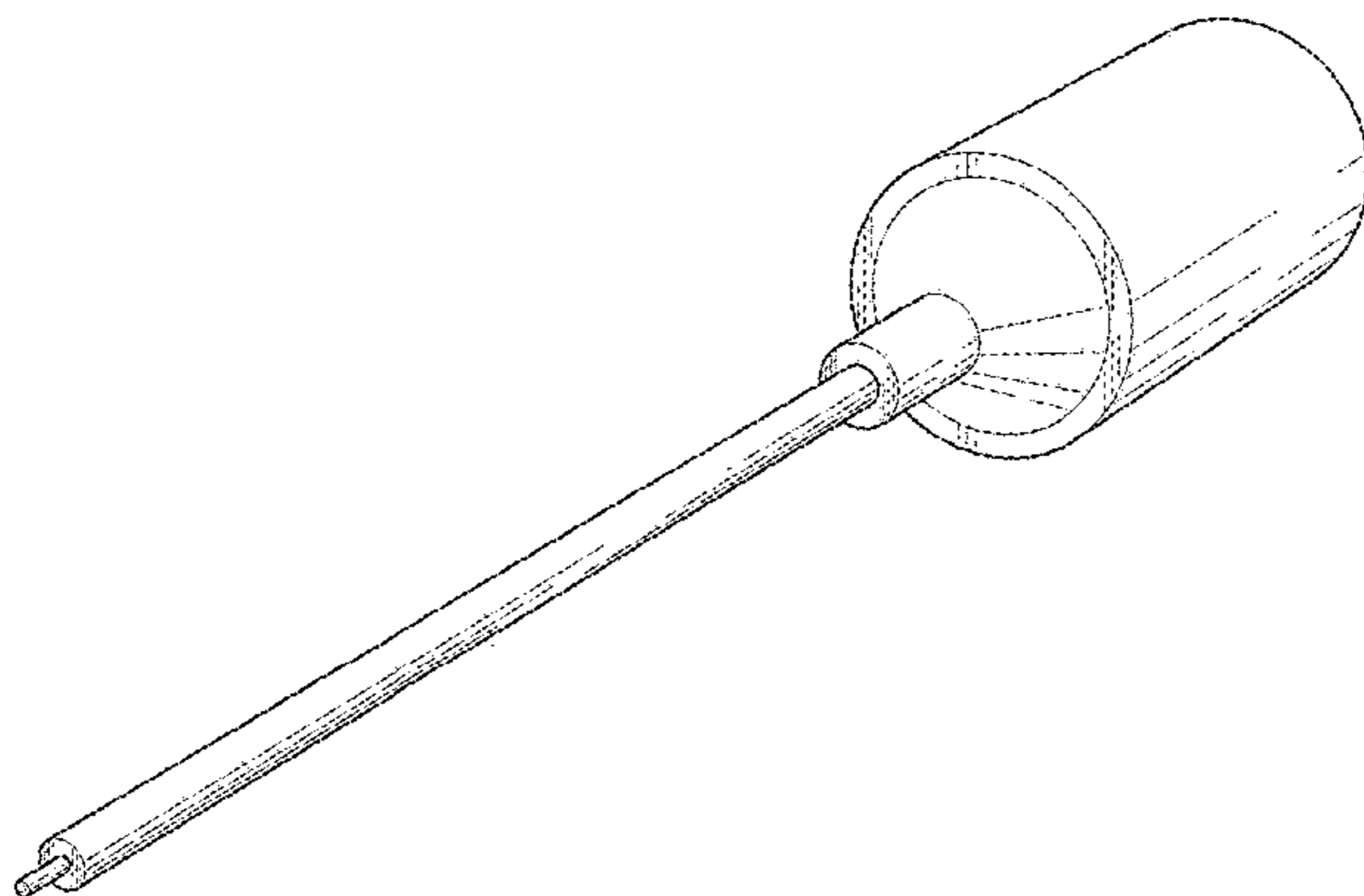

FIG. 22 is an enlarged fragmentary front perspective view of fragment 22-22 in the same alternate configuration of the second embodiment showing an alternate condition of the second embodiment as in FIG. 20 of my new design and the jagged line indicates the rear end of the fragment.

1 Claim, 22 Drawing Sheets

(58) **Field of Classification Search**

CPC B01F 13/0025; B01J 2219/00292; B01J 2220/64; B01L 3/14; B01L 3/508-50825; B01L 3/52-523

See application file for complete search history.

(56) **References Cited**

U.S. PATENT DOCUMENTS

D373,827 S 9/1996 Polaniec D24/112
 D384,418 S 9/1997 Torti D24/222
 D387,426 S * 12/1997 Husar D24/112

D401,698 S 11/1998 Daniels D24/222
 D441,458 S 5/2001 Petrek D24/222
 D468,439 S 1/2003 On D24/222
 D468,830 S 1/2003 On D24/222
 D468,831 S 1/2003 On D24/222
 D569,989 S 5/2008 Tajima D24/222
 D601,712 S 10/2009 Tajima D24/222
 D630,321 S 1/2011 Hamilton D24/133
 8,518,347 B2 8/2013 Tajima 422/501
 D709,623 S 7/2014 Lohn D24/222
 D733,909 S 7/2015 Lohn D24/222
 D733,910 S 7/2015 Lohn D24/222
 D740,436 S 10/2015 Lohn D24/222
 D740,437 S 10/2015 Lohn D24/222
 9,421,538 B1 8/2016 Sung
 D771,250 S * 11/2016 Zhang D24/133
 D787,698 S 5/2017 Staton D24/222
 D788,314 S 5/2017 Ando D24/222
 10,005,594 B2 6/2018 Tajima
 10,094,746 B2 * 10/2018 Dimson G01N 1/10
 D846,143 S * 4/2019 Ito D24/222
 2008/0078258 A1 4/2008 Price 73/864.01
 2014/0308655 A1 10/2014 Mogas 435/2
 2017/0001190 A1 1/2017 Ito

* cited by examiner

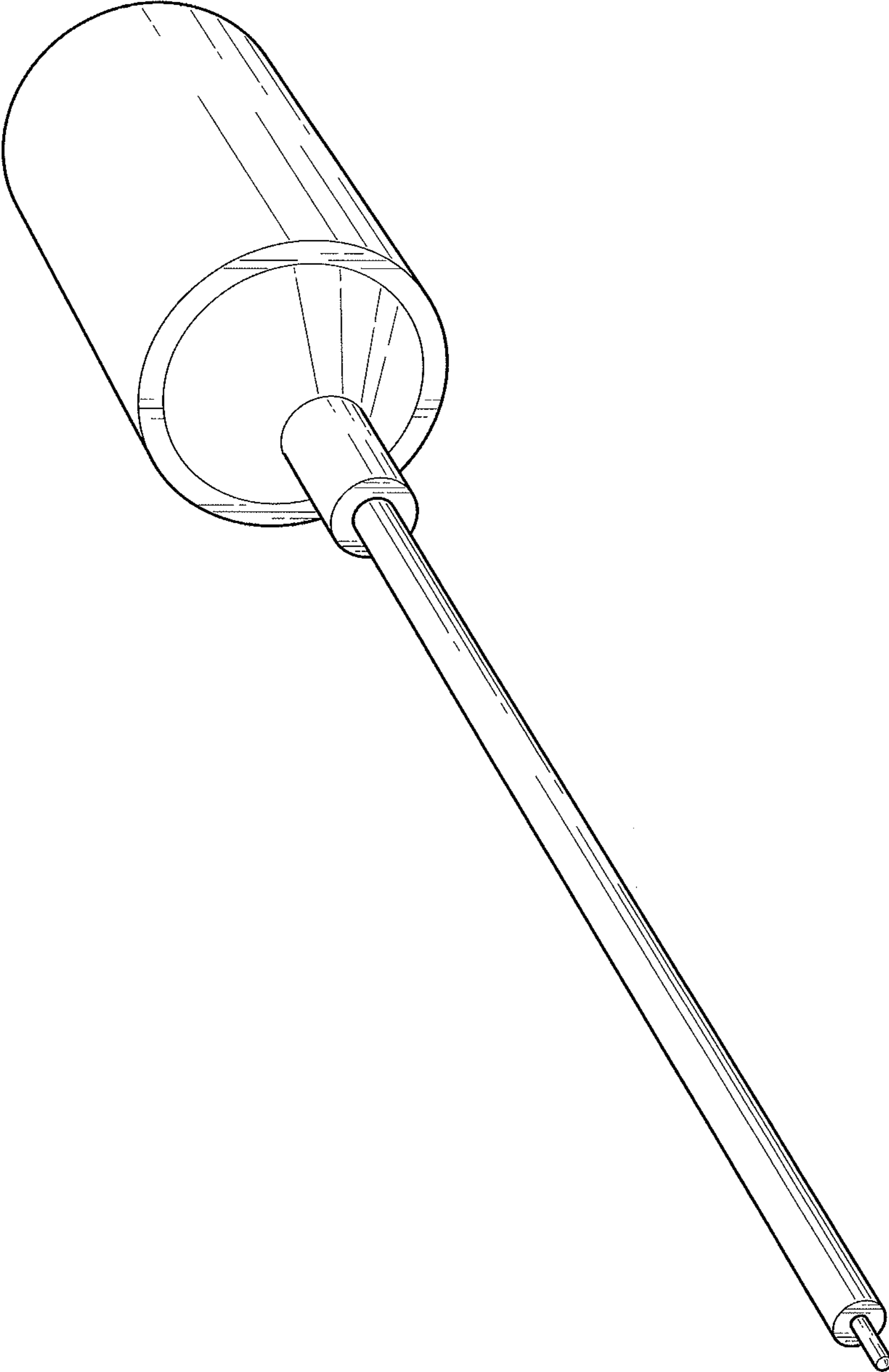

Fig.1

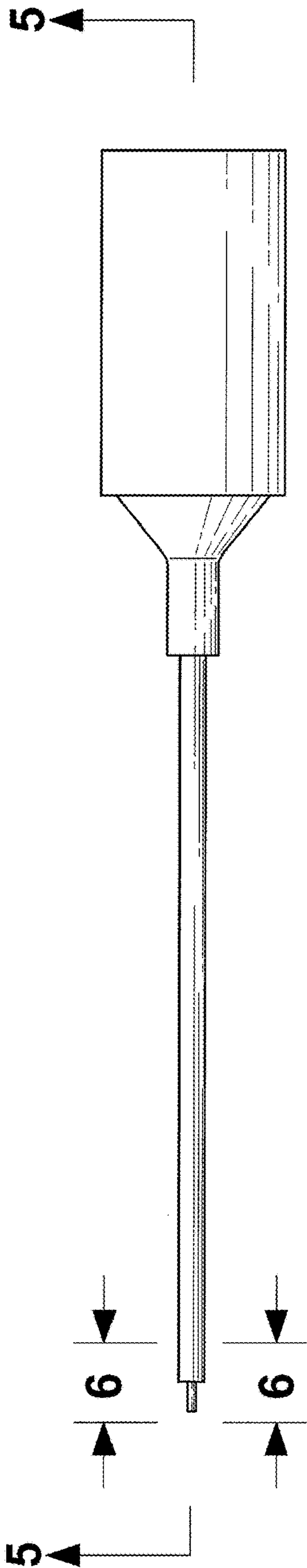

Fig.2

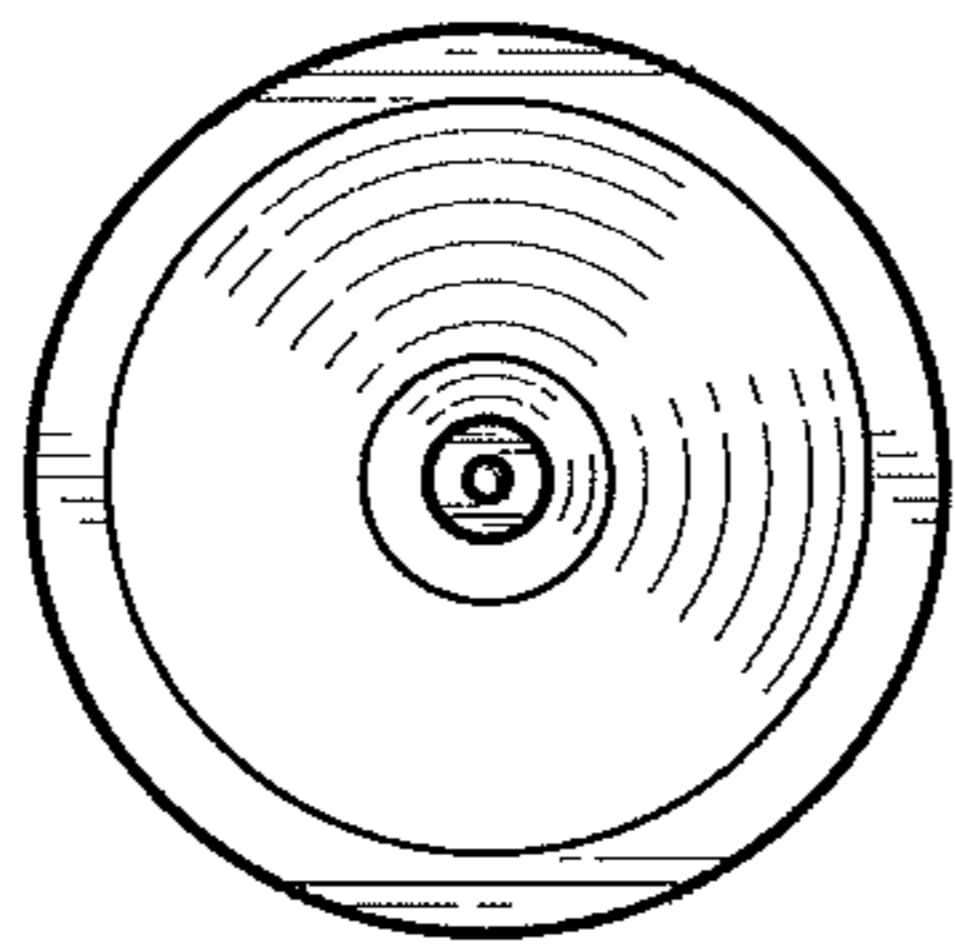

Fig. 3

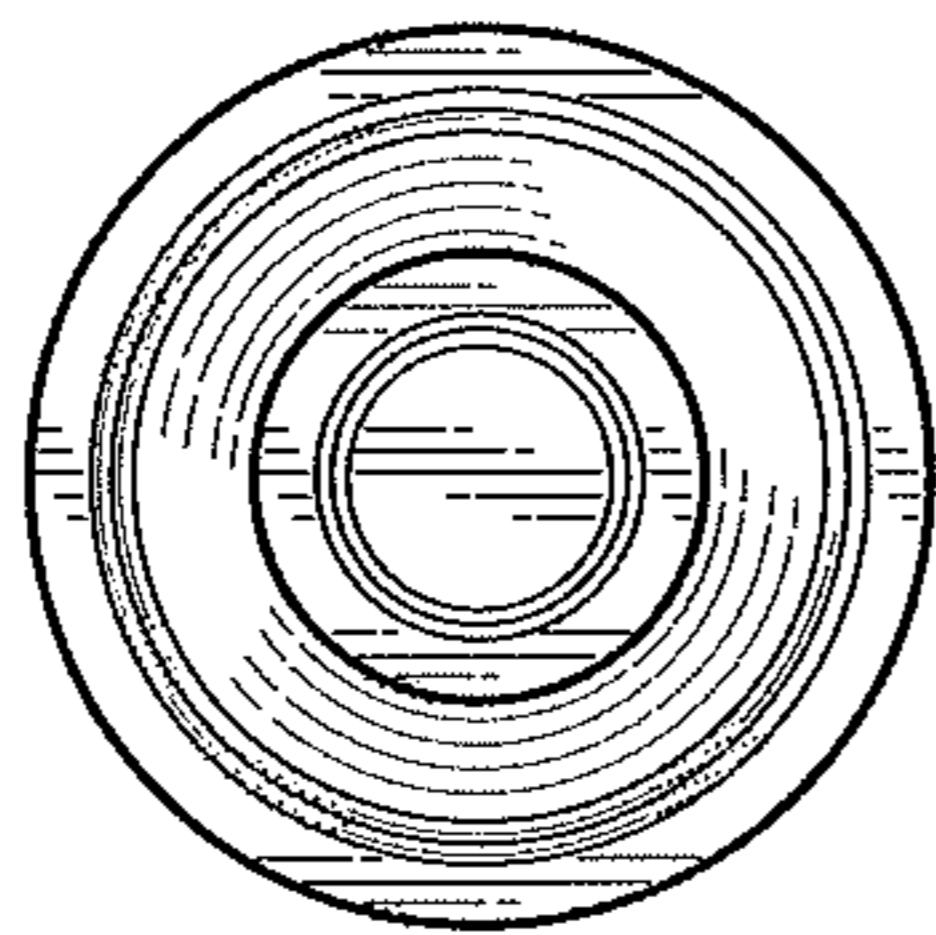

Fig.4

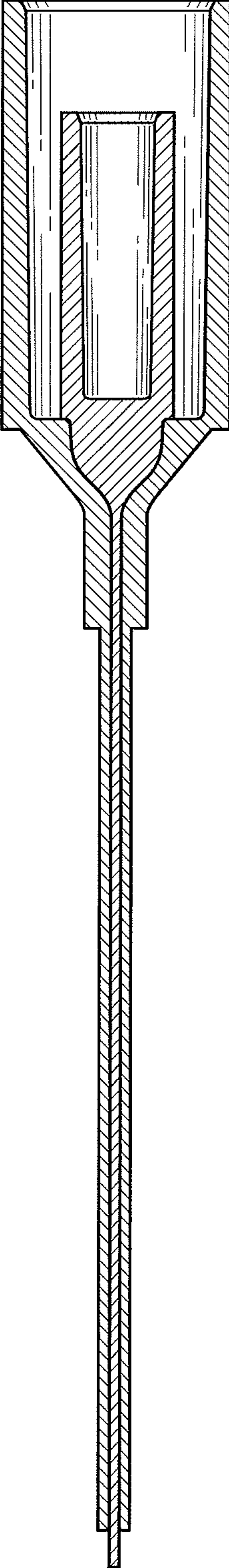

Fig.5

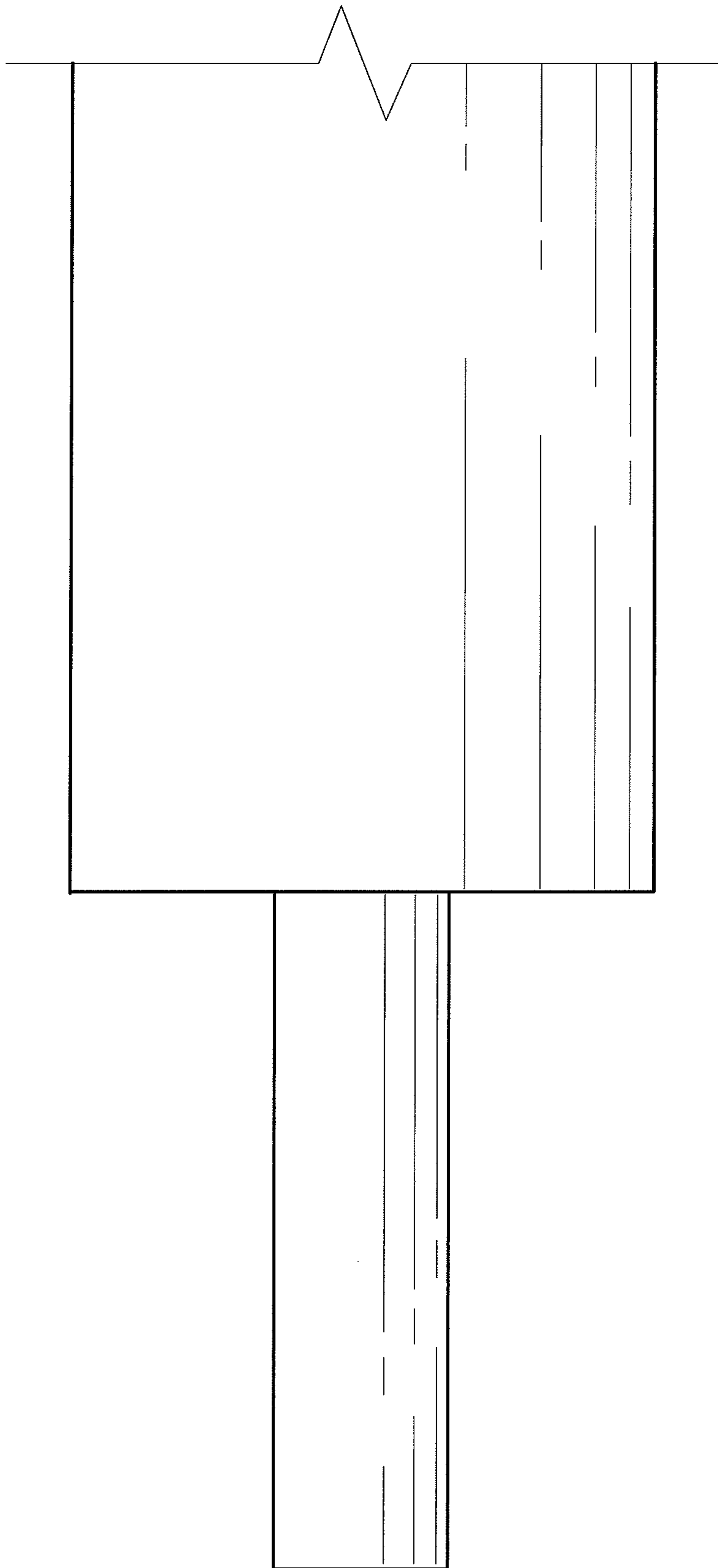

Fig.6

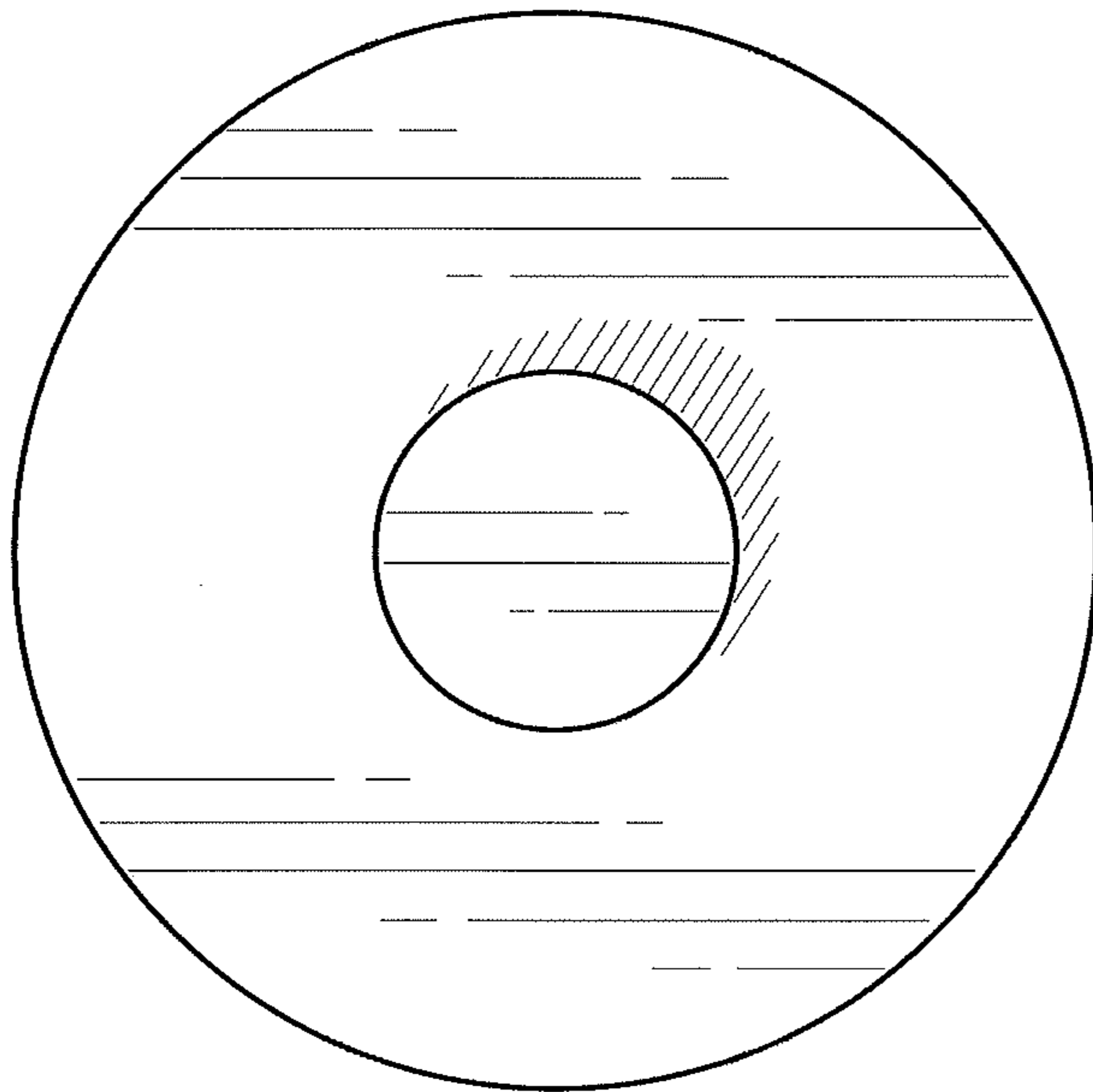

Fig.7

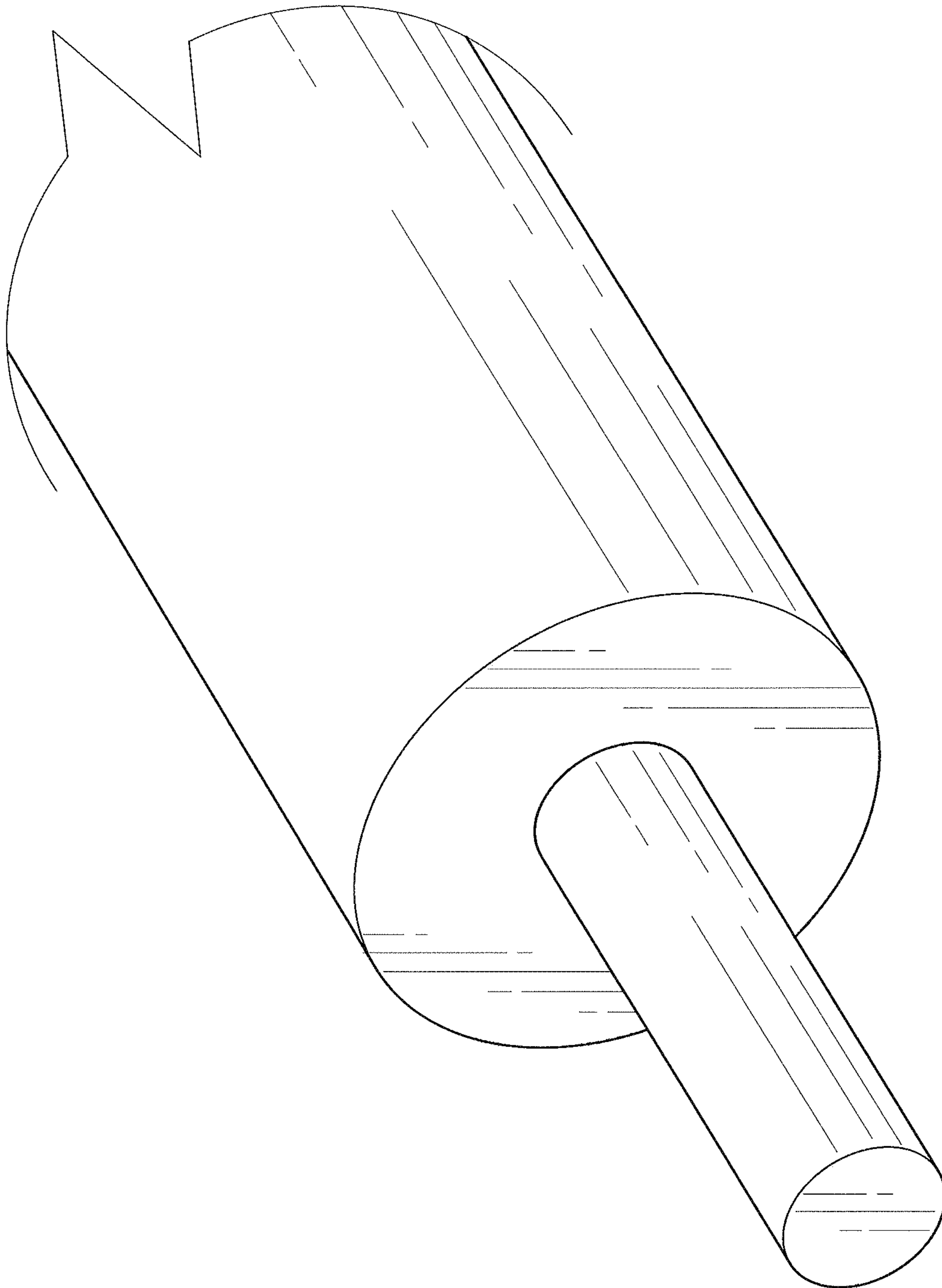

Fig. 8

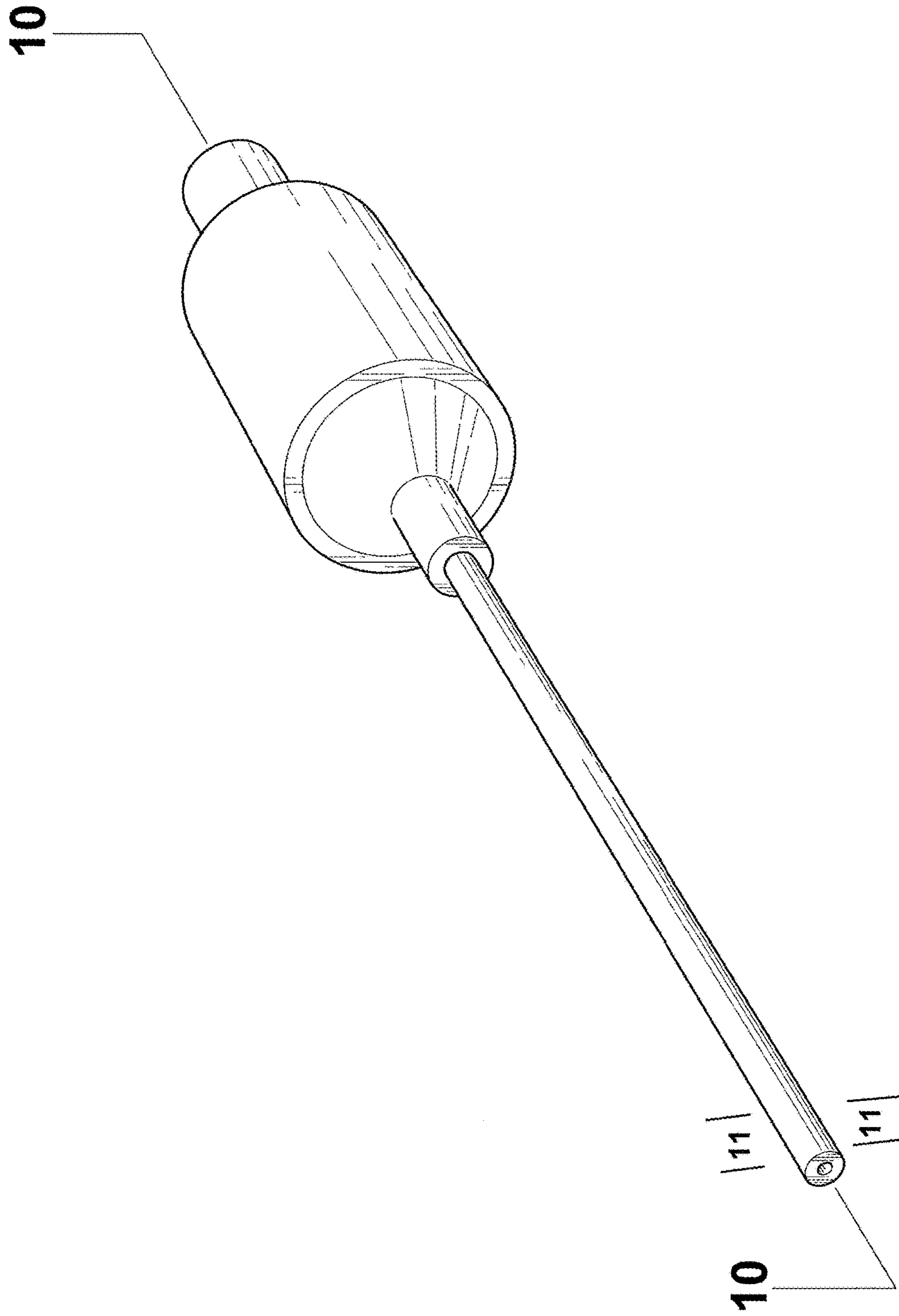

Fig.9

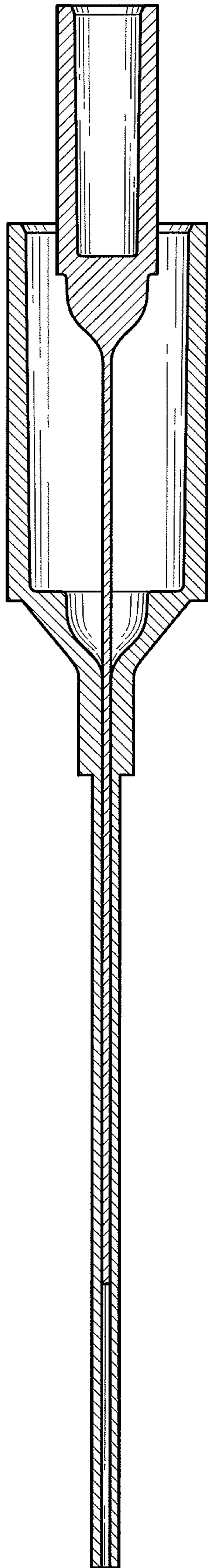

Fig.10

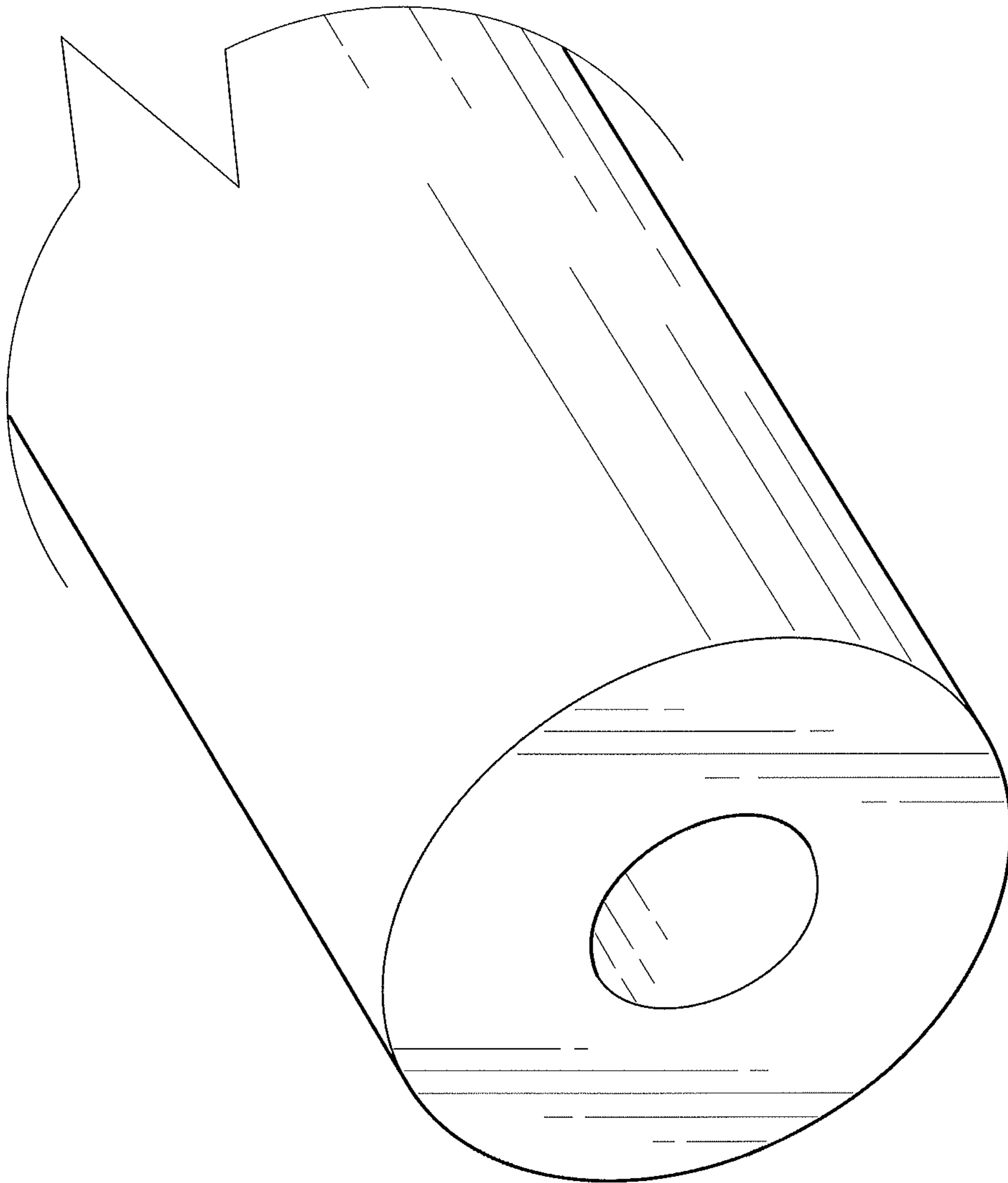

Fig.11

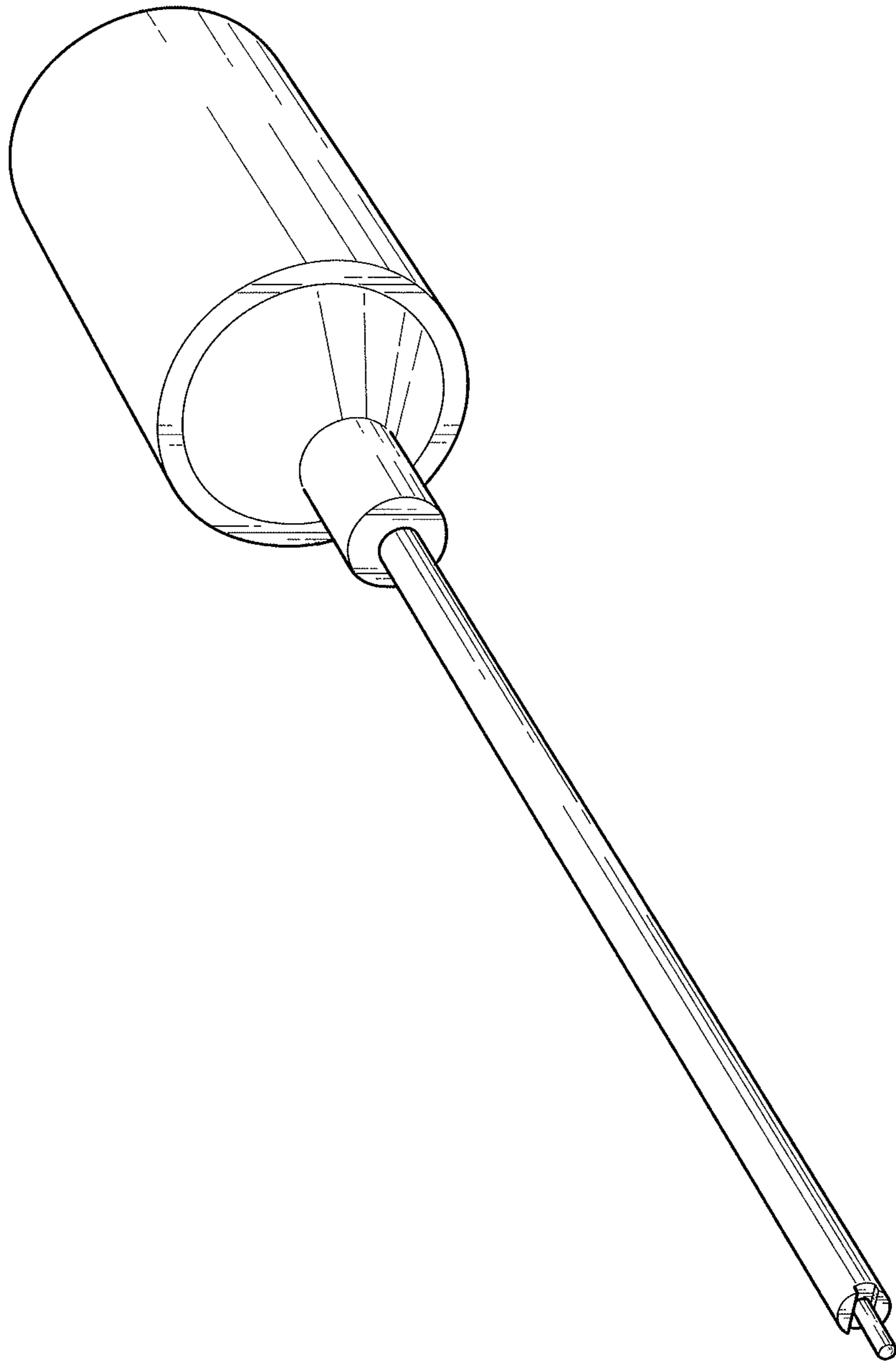

Fig.12

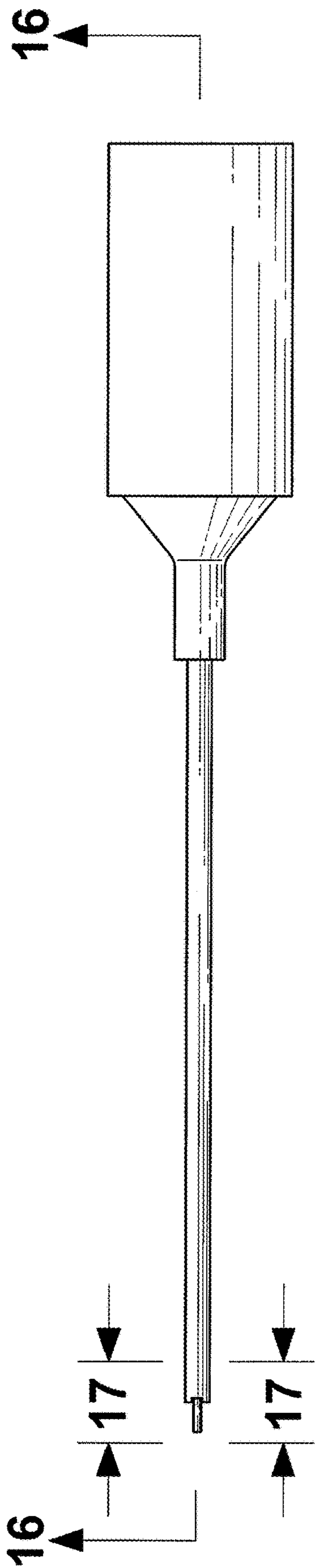

Fig.13

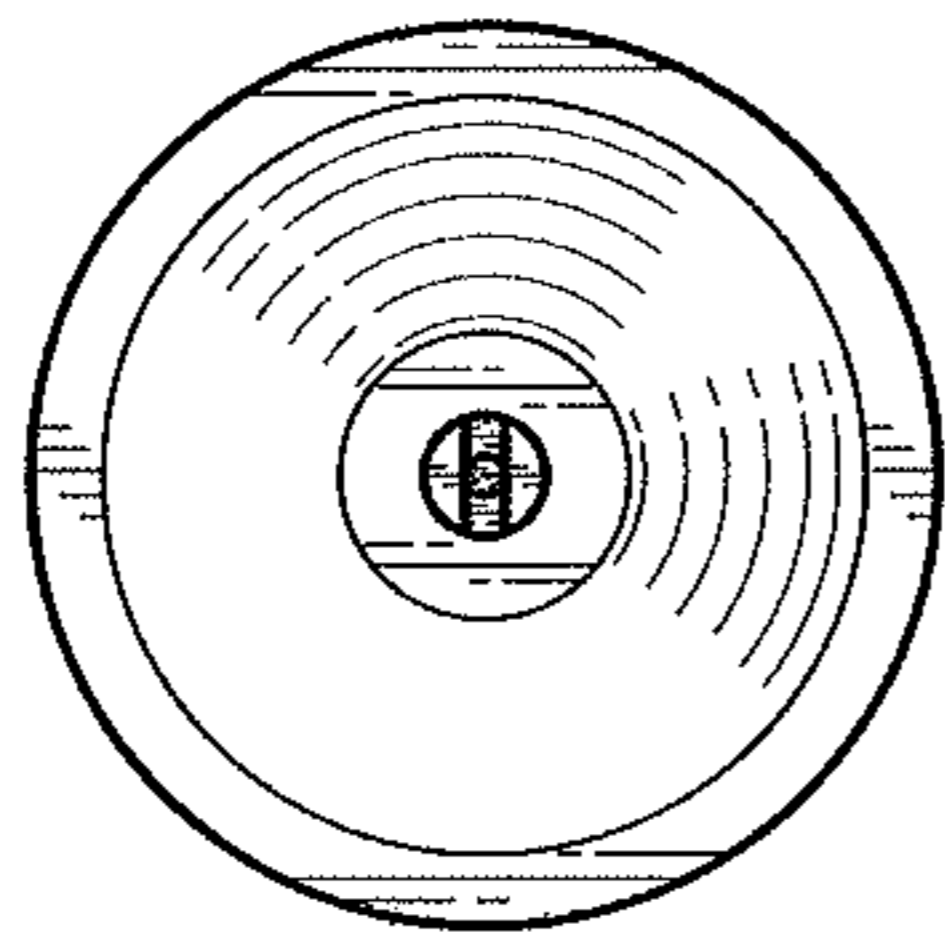

Fig.14

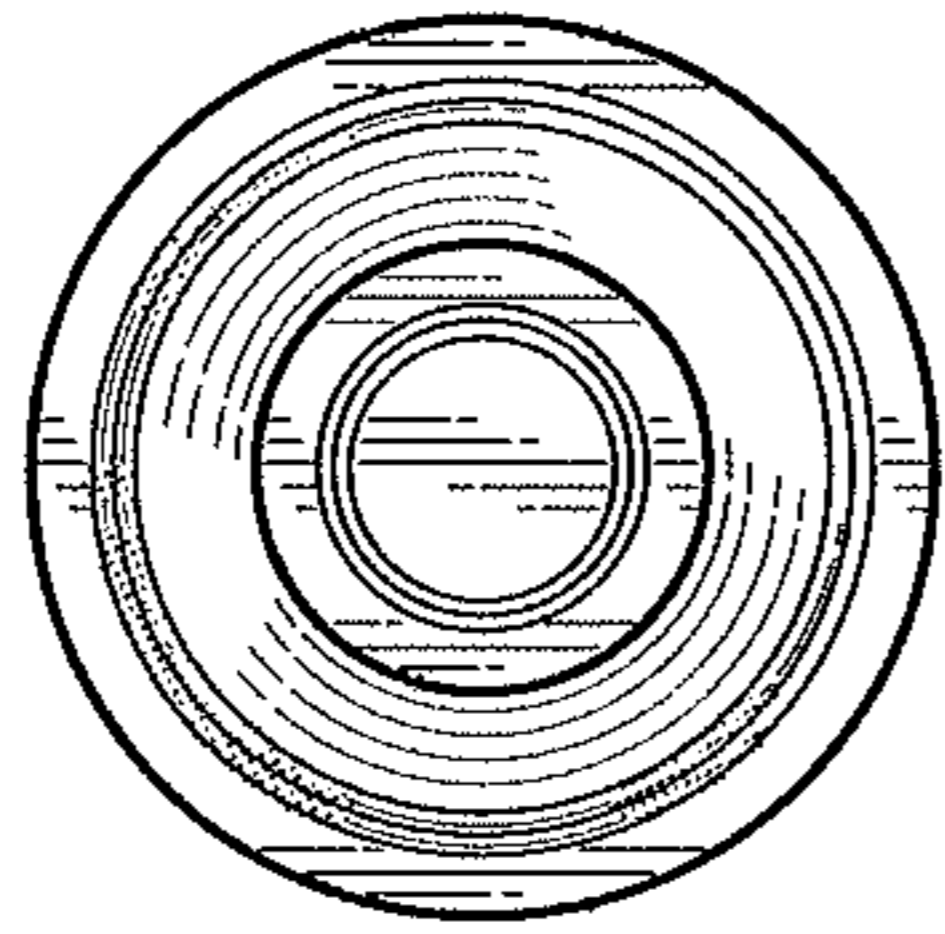

Fig.15

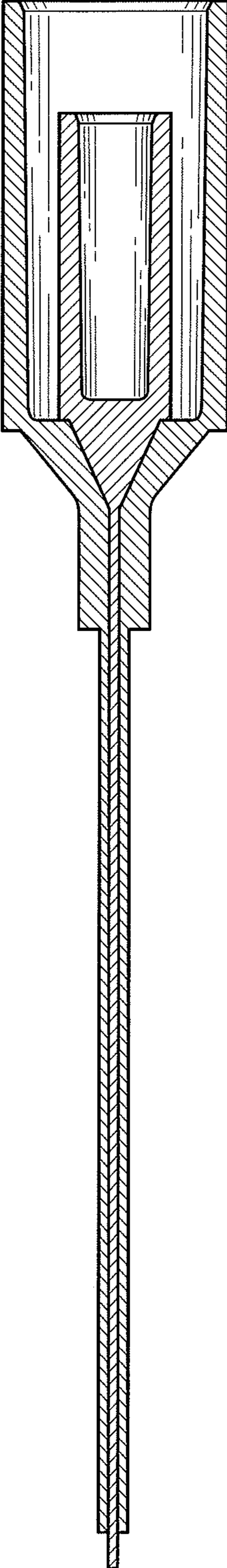

Fig.16

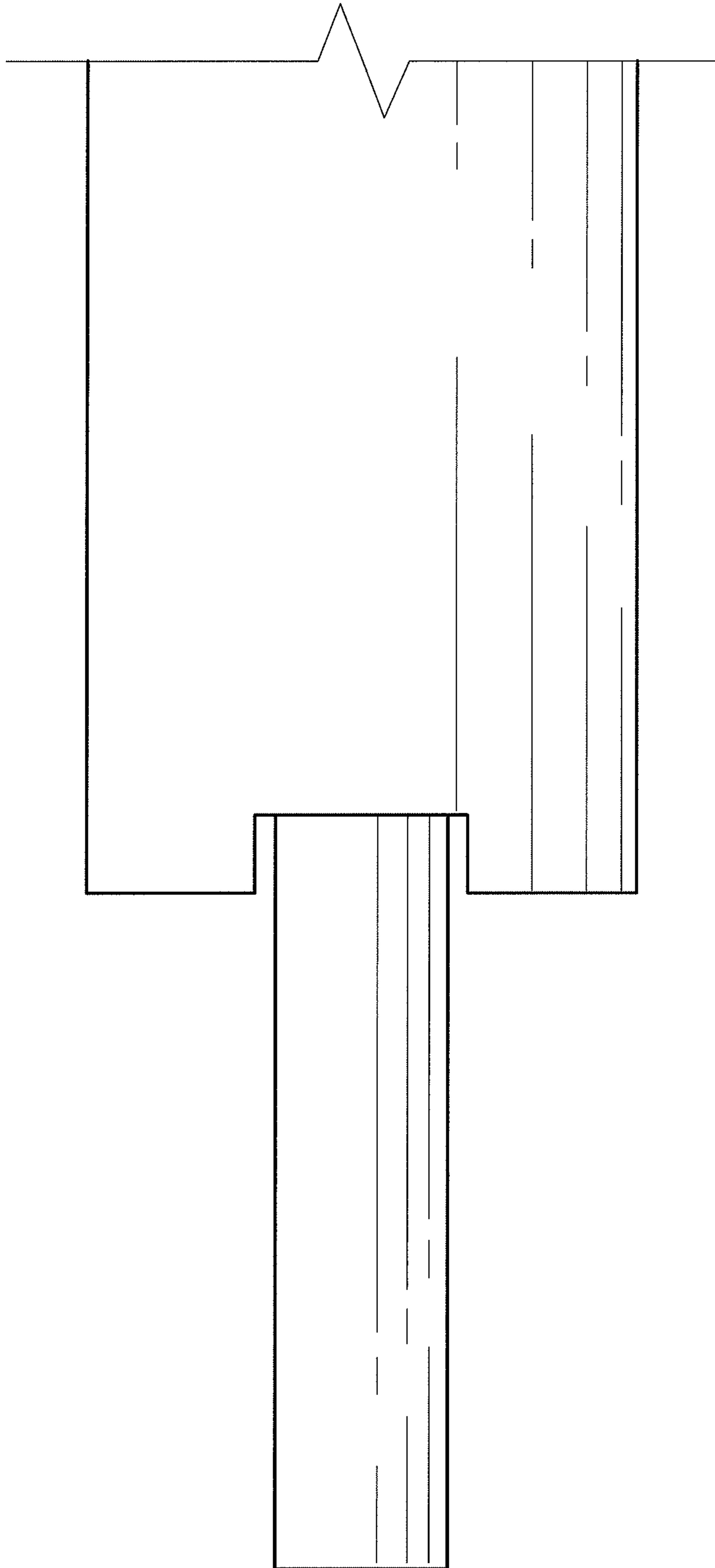

Fig.17

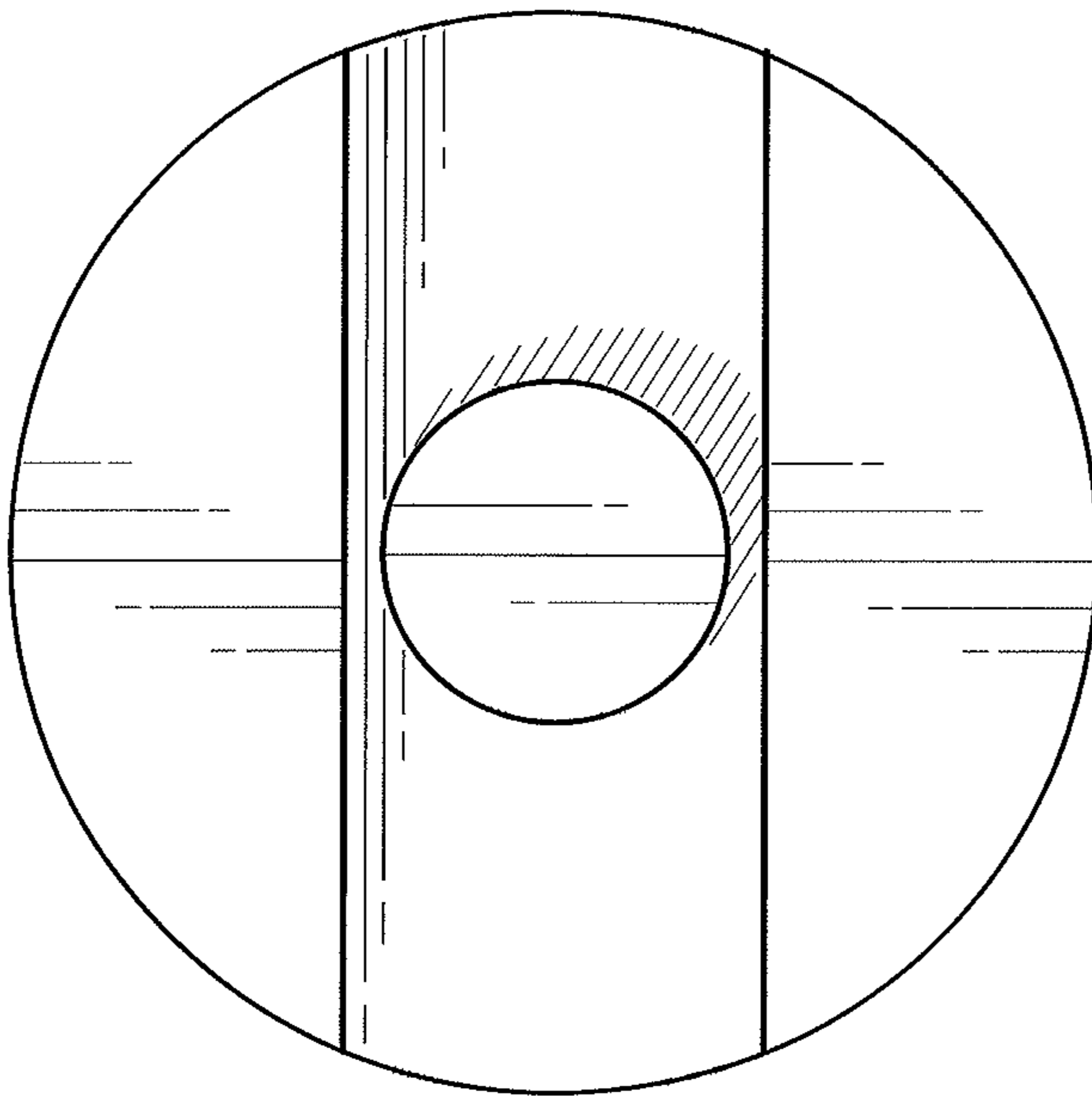

Fig.18

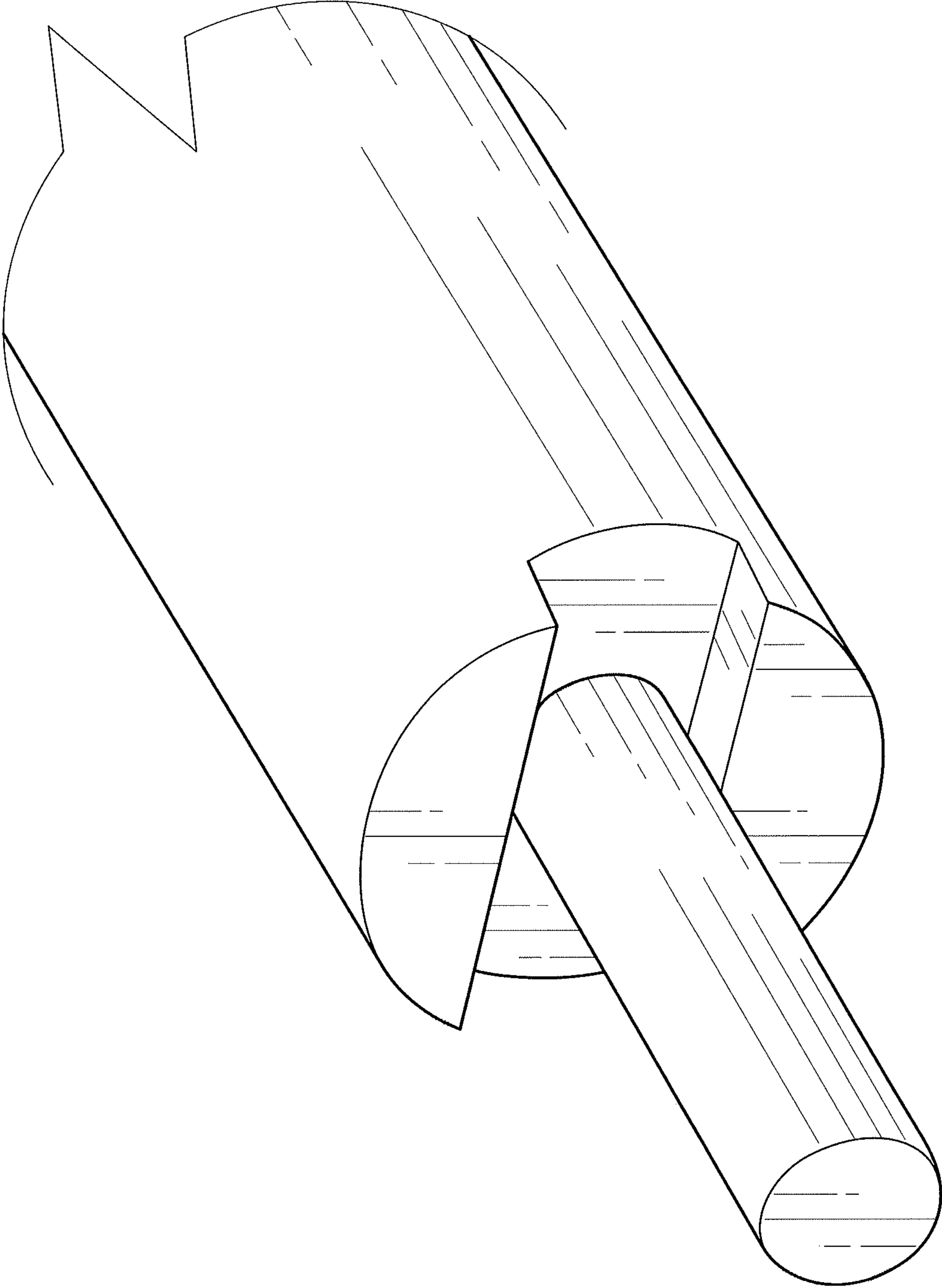

Fig.19

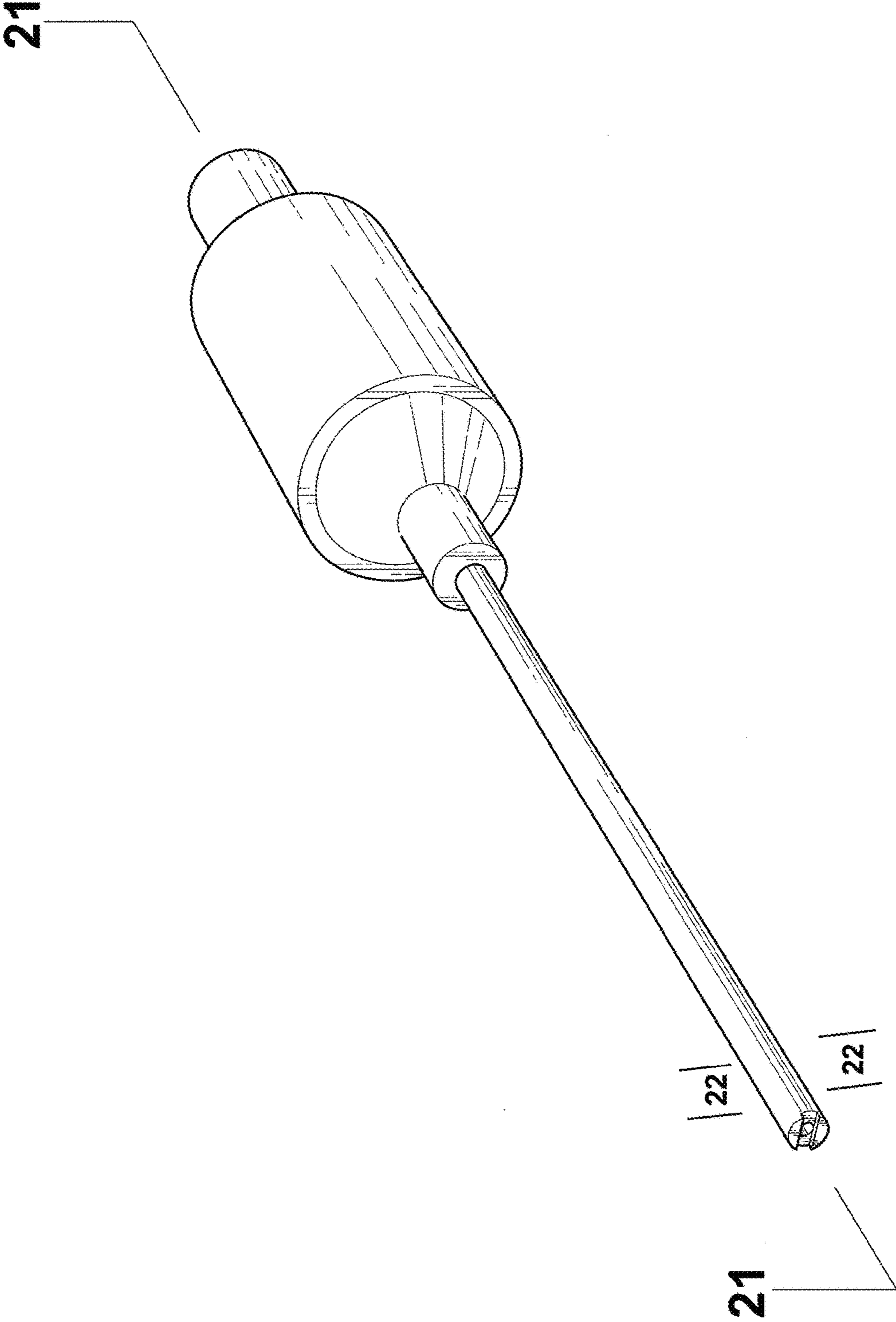

Fig.20

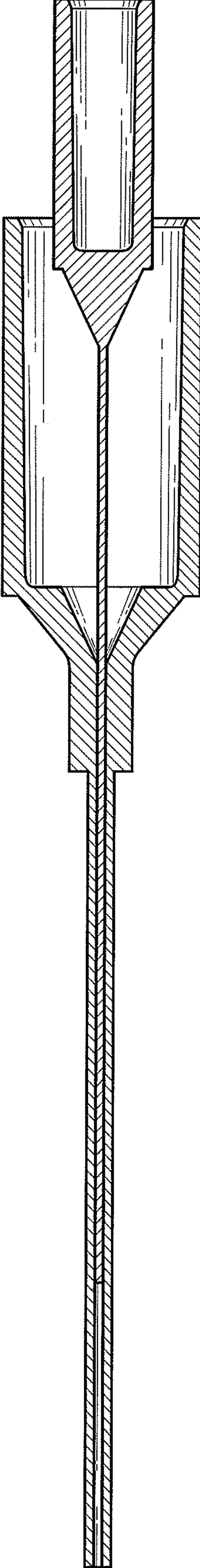

Fig.21

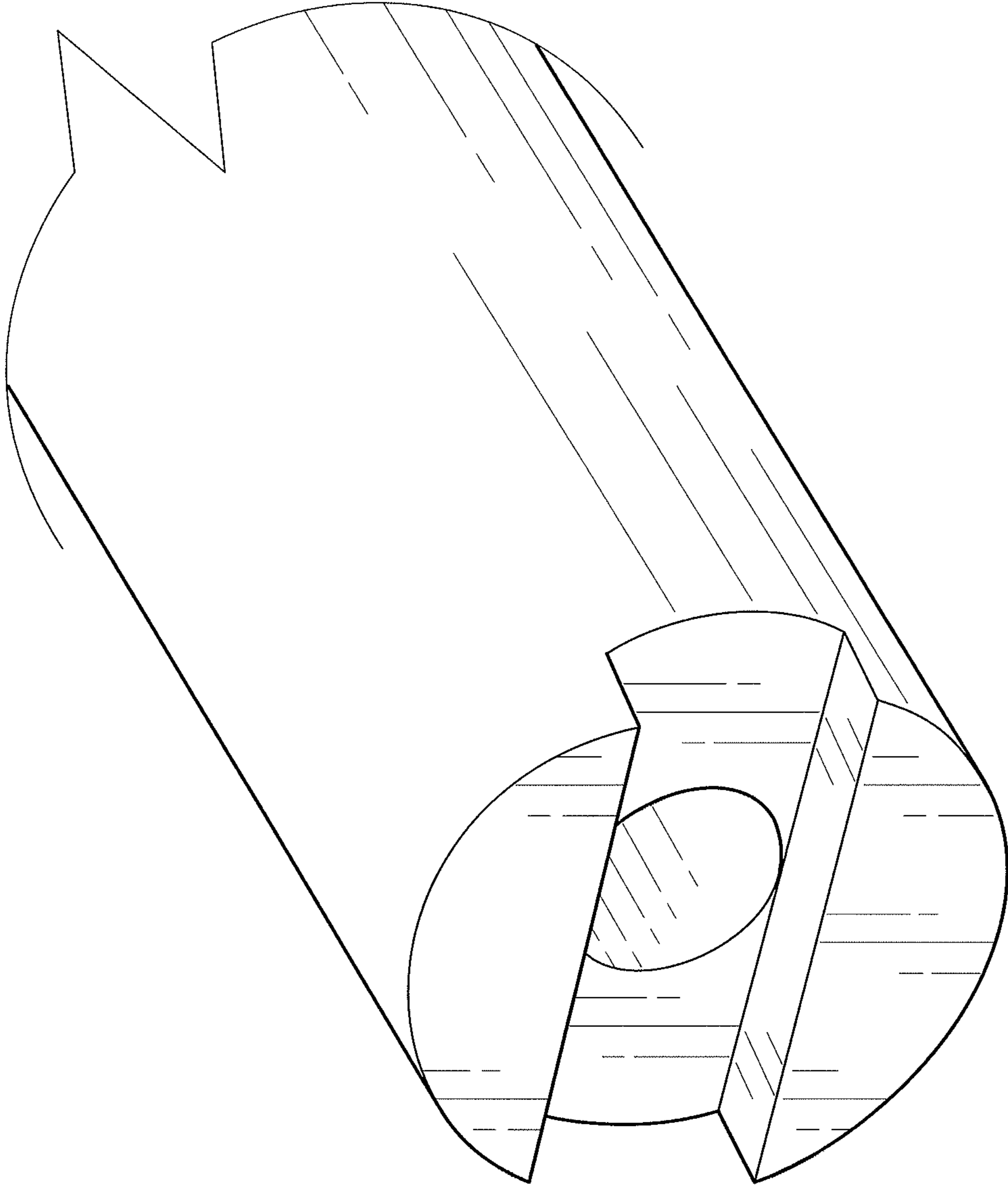

Fig.22