



US00D877276S

(12) **United States Design Patent**  
**Ribelin et al.**

(10) **Patent No.:** **US D877,276 S**  
(45) **Date of Patent:** **\*\* Mar. 3, 2020**

(54) **SUPPRESSED PISTOL**

(71) Applicant: **SilencerCo, LLC**, West Valley City, UT (US)

(72) Inventors: **Rex Ribelin**, Cottonwood Heights, UT (US); **Jacob Scott Turnblom**, Murray, UT (US)

(73) Assignee: **SilencerCo, LLC**, West Valley City, UT (US)

(\*\*) Term: **15 Years**

(21) Appl. No.: **29/664,216**

(22) Filed: **Sep. 24, 2018**

**Related U.S. Application Data**

(62) Division of application No. 29/583,211, filed on Nov. 3, 2016, now Pat. No. Des. 829,292.

(51) **LOC (12) Cl.** ..... **22-01**

(52) **U.S. Cl.**  
USPC ..... **D22/104**

(58) **Field of Classification Search**

USPC ..... D22/100, 104, 108, 109, 199;  
D21/572-575, 145, 146, 147, 567;  
D14/418; 124/16, 25.7, 27, 45, 82, 23.1,  
124/35.2, 37, 79; 446/401, 403, 400,  
446/473, 445, 182, 405, 407; 248/200;  
D8/354, 373, 380, 499; 42/4, 41, 42.01,  
42/42.02, 42.03, 43, 44, 45, 57, 69.01,  
42/71.02, 72, 100; 89/40.06, 41.19,  
89/37.04, 33.04, 191.01, 200-204;  
362/110, 113  
CPC .... F41C 3/005; F41C 3/02; F41C 3/04; F41C  
3/06; F41C 3/14; F41C 3/16; F41C 9/02;  
F41C 9/04; F41C 9/06; F41C 9/08

See application file for complete search history.

(56) **References Cited**

U.S. PATENT DOCUMENTS

D330,749 S \* 11/1992 Aigner ..... D22/104  
5,522,167 A \* 6/1996 Teetzel ..... F41A 9/62  
250/208.4  
D458,652 S 6/2002 Chan  
D508,277 S \* 8/2005 Cerovic ..... D21/574  
D521,568 S \* 5/2006 Hussaini ..... D14/418  
(Continued)

OTHER PUBLICATIONS

SilencerCo Maxim 9 Overview, YouTube.com, Capitol Armory, Published on May 17, 2017, [online], [site visited Jul. 25, 2019]. <URL: [https://www.youtube.com/watch?v=0ee\\_3esmxY](https://www.youtube.com/watch?v=0ee_3esmxY)> (Year: 2017).\*

(Continued)

*Primary Examiner* — T Chase Nelson  
*Assistant Examiner* — Jonathan J. Han

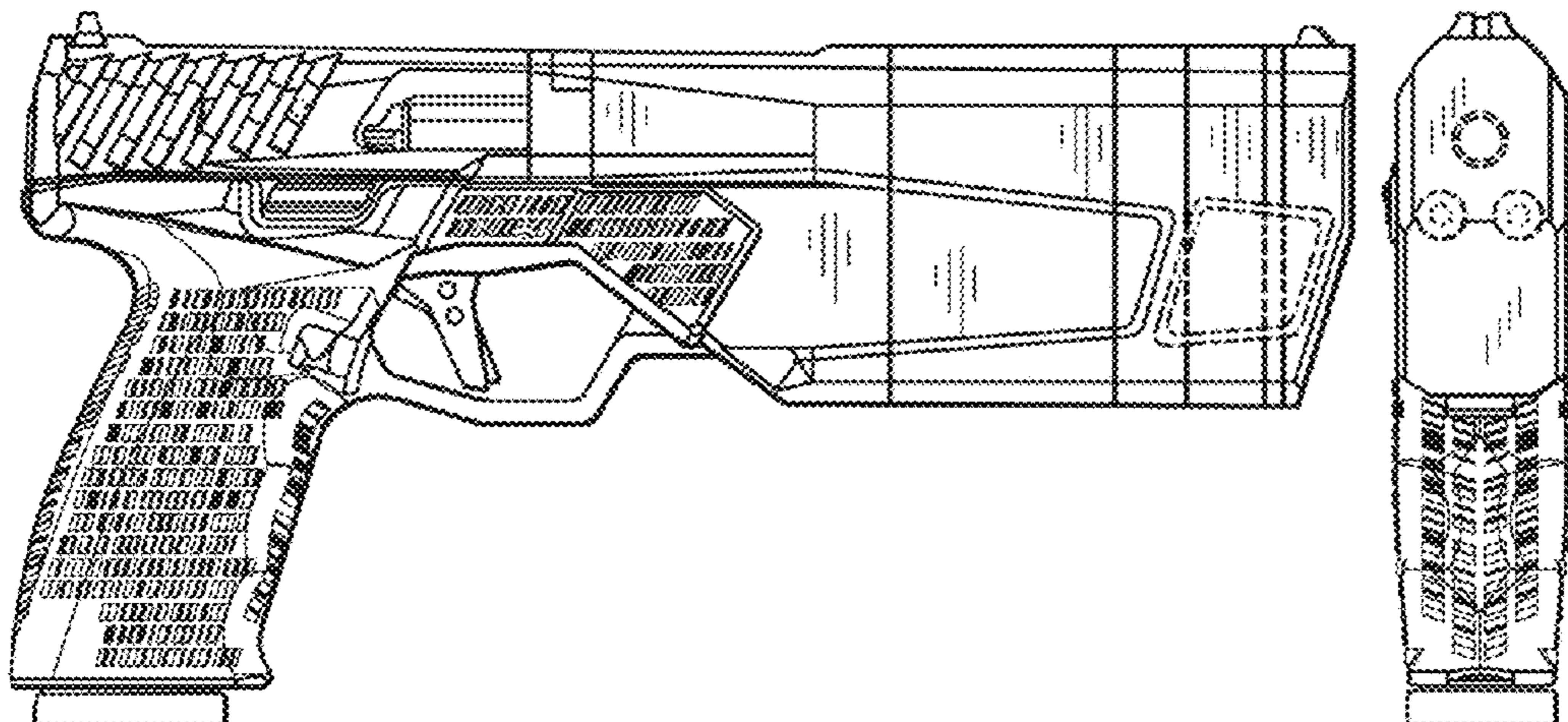
(57) **CLAIM**

The ornamental design for a suppressed pistol, as shown and described.

**DESCRIPTION**

FIG. 1 is a right side view of our design of a suppressed pistol according to our invention;  
FIG. 2 is a left side view of the suppressed pistol shown in FIG. 1;  
FIG. 3 is a top view of the suppressed pistol shown in FIG. 1;  
FIG. 4 is a bottom view of the suppressed pistol shown in FIG. 1;  
FIG. 5 is a front view of the suppressed pistol shown in FIG. 1; and,  
FIG. 6 is a rear view of the suppressed pistol shown in FIG. 1.  
The broken lines in the figures show portions of the suppressed pistol that form no part of the claimed design.

**1 Claim, 2 Drawing Sheets**



(56)

References Cited

U.S. PATENT DOCUMENTS

7,287,526 B1 \* 10/2007 Bligh ..... F41B 11/643  
124/63  
D583,896 S \* 12/2008 McGarry ..... D22/104  
D584,374 S \* 1/2009 McGarry ..... D22/104  
D593,622 S \* 6/2009 Halmone ..... D21/574  
D593,623 S \* 6/2009 Halmone ..... D21/574  
D593,629 S \* 6/2009 Bantle ..... D22/104  
D627,028 S \* 11/2010 Coulombier ..... D22/104  
D630,290 S \* 1/2011 Velasquez ..... D22/104  
D636,031 S \* 4/2011 Torre ..... D21/573  
D651,275 S \* 12/2011 Emde ..... D22/104  
D654,118 S \* 2/2012 Sogabe ..... D14/218  
D660,923 S \* 5/2012 Johnson ..... D21/573  
D660,925 S \* 5/2012 Jablonski ..... D21/573  
D664,609 S \* 7/2012 Johnson ..... D21/574  
8,312,658 B2 11/2012 Lippard  
D678,454 S \* 3/2013 Emde ..... D22/104  
D681,131 S \* 4/2013 Su ..... D21/574  
8,448,365 B2 \* 5/2013 Mead ..... F41B 7/003  
42/54  
D687,117 S 7/2013 Yigit  
D702,794 S \* 4/2014 Chow ..... D22/104  
D716,899 S 11/2014 Rothmann  
D742,989 S 11/2015 Holden  
D754,258 S \* 4/2016 Sakai ..... D14/418  
D754,796 S \* 4/2016 Sakai ..... D14/418  
D754,802 S \* 4/2016 Martelli ..... D21/574  
D755,907 S \* 5/2016 Hu ..... D21/574  
D758,519 S 6/2016 Toner  
D778,389 S 2/2017 Holden

D794,739 S \* 8/2017 Kedairy ..... D22/104  
D808,487 S \* 1/2018 Beville ..... D22/104  
D829,292 S \* 9/2018 Ribelin ..... D22/104  
D842,393 S \* 3/2019 Xiao ..... D21/575  
D847,136 S \* 4/2019 Tenbrink ..... D14/418  
2006/0010746 A1 1/2006 Little  
2009/0282718 A1 \* 11/2009 Bartley ..... F41C 23/12  
42/75.03  
2011/0072704 A1 \* 3/2011 Teach, Jr. .... F41A 3/58  
42/8  
2012/0279105 A1 \* 11/2012 Emde ..... F41A 11/04  
42/1.08  
2017/0205173 A1 \* 7/2017 Thomas ..... F41A 3/40

OTHER PUBLICATIONS

Maxim 9 Product Overview, Silencerco.com, [online], [site visited Jul. 25, 2019]. <URL: <https://silencerco.com/maxim-9>> (Year: 2019).\*

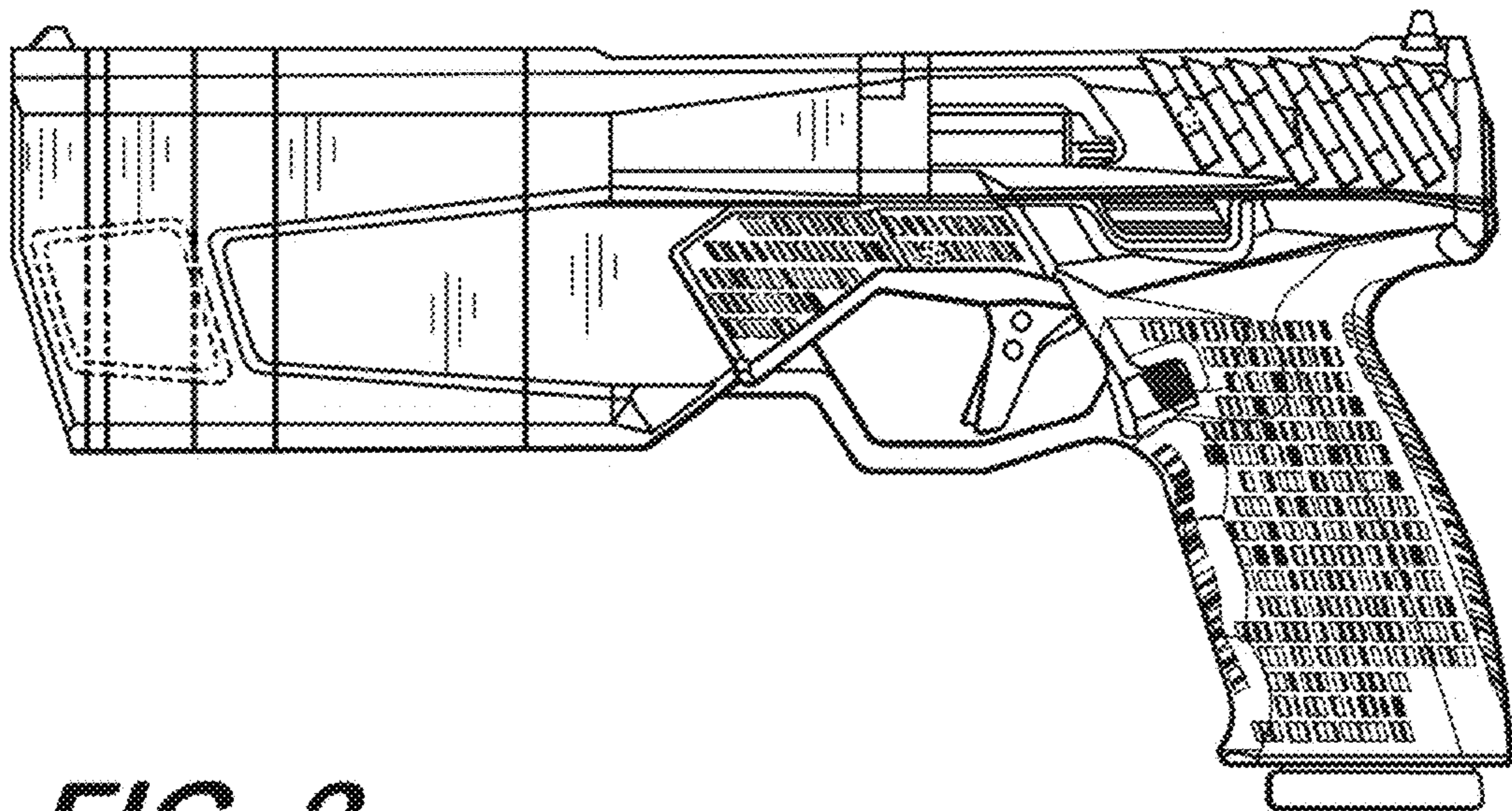
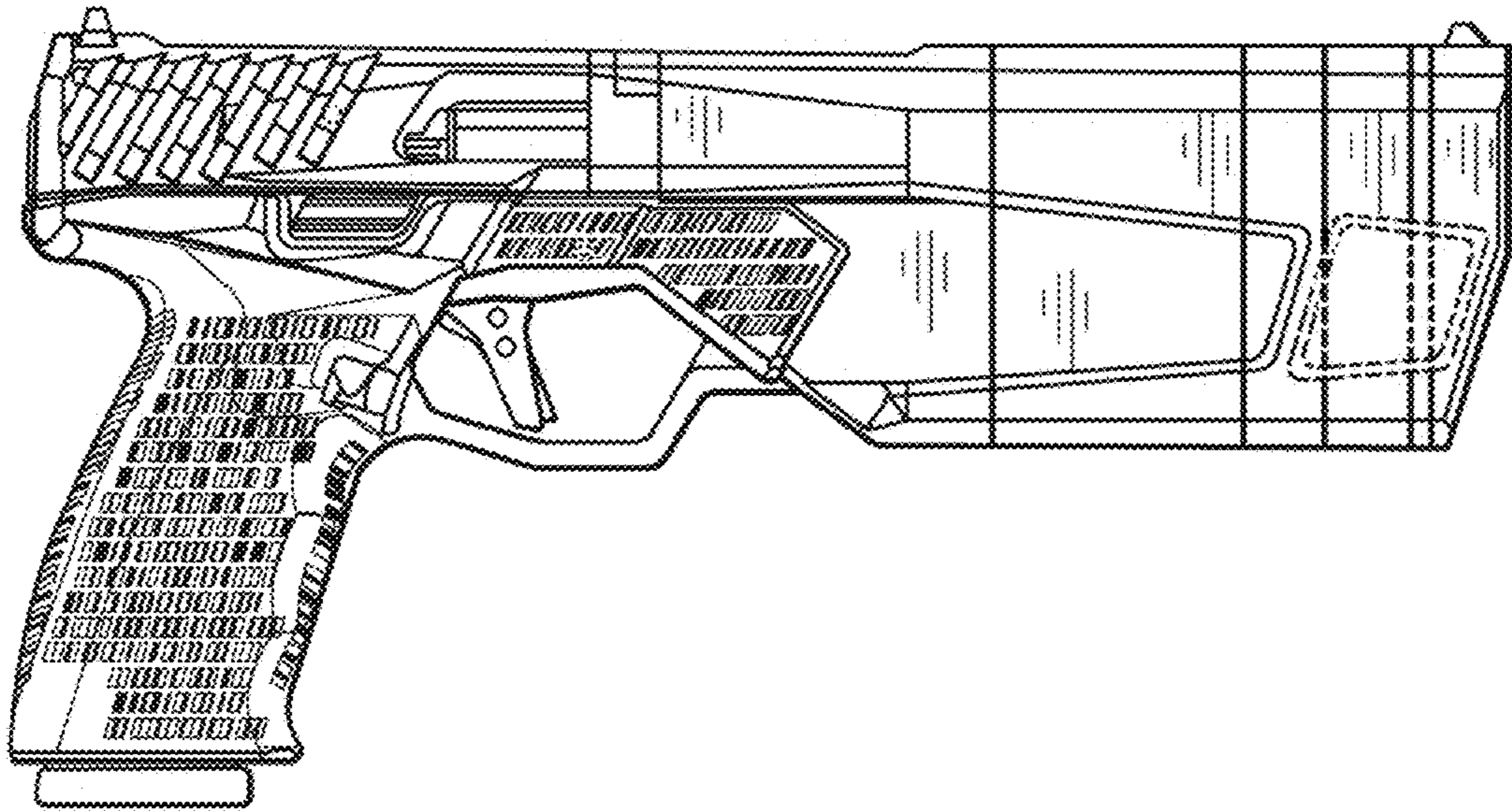
Maxim 9 SilencerCo, integrally suppressed pistol, New-WeaponsAndMore.blogspot.com, Sep. 16, 2015, [online], [site visited Jul. 25, 2019]. <URL: <https://newweaponsandmore.blogspot.com/2015/09/maxim-9-silencerco-integrally.html#!/2015/09/maxim-9-silencerco-integrally.html>> (Year: 2015).\*

3D Sci-fi Handgun, Turbosquid.com, Published: Jun 29, 2018, [online], [site visited Jul. 25, 2019]. <URL: <https://www.turbosquid.com/3d-models/3d-sci-fi-handgun-1301452>> (Year: 2018).\*

NFA Review Channel—YouTube, Silencerco Maxim 9, Sep. 17, 2015, [site visited Aug. 31, 2016], Available on the Internet YRL:<<https://www.youtube.com/watch?v=BhK7F7kt50g>>.

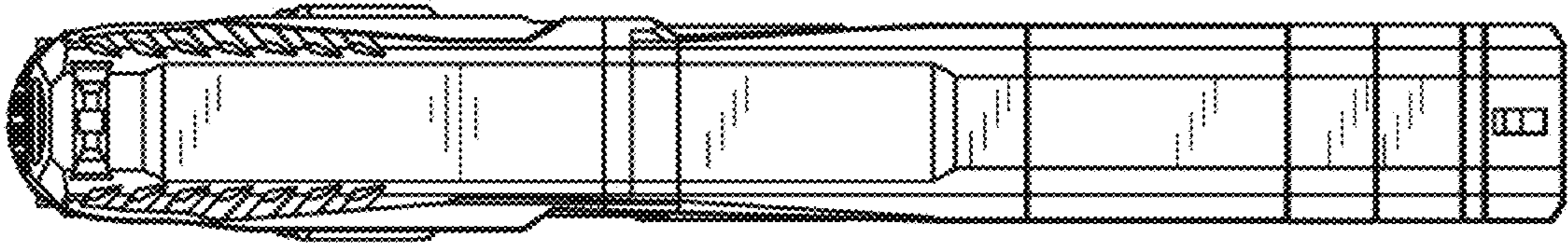
\* cited by examiner

**FIG. 1**

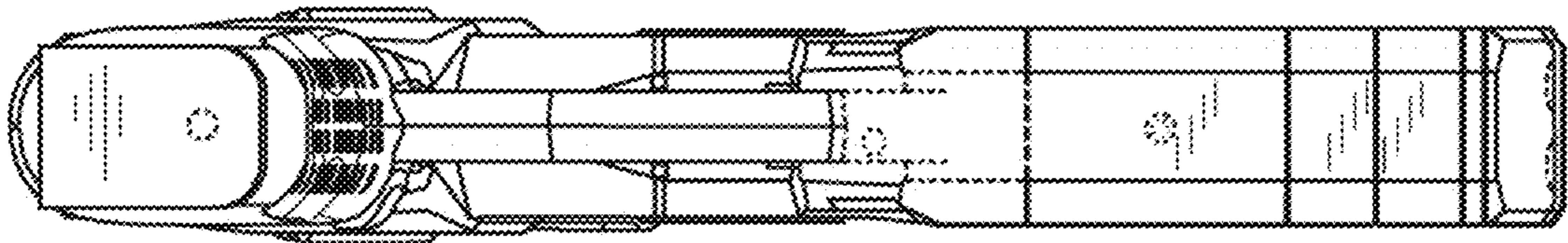


**FIG. 2**

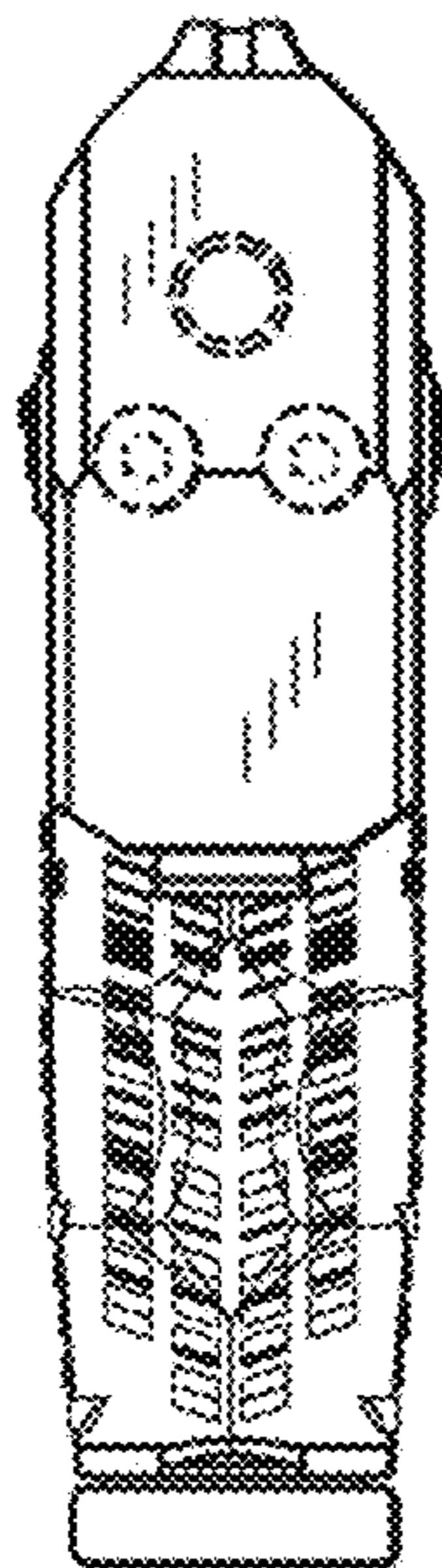
**FIG. 3**



**FIG. 4**



**FIG. 5**



**FIG. 6**

