



US00D877257S

(12) **United States Design Patent**
Cao

(10) **Patent No.:** **US D877,257 S**
(45) **Date of Patent:** **** Mar. 3, 2020**

(54) **SCOOTER**

(71) Applicant: **Zhejiang Taotao Vehicles Co., Ltd.**,
Lishui, Zhejiang Province (CN)

(72) Inventor: **Matao Cao**, Yongkang (CN)

(73) Assignee: **ZHEJIANG TAOTAO VEHICLES**
CO., LTD., Lishui, Zhejiang Province
(CN)

(**) Term: **15 Years**

(21) Appl. No.: **29/666,796**

(22) Filed: **Oct. 16, 2018**

(30) **Foreign Application Priority Data**

Apr. 21, 2018 (CN) 2018 3 0168001

(51) **LOC (12) Cl.** **21-01**

(52) **U.S. Cl.**
USPC **D21/423**

(58) **Field of Classification Search**

USPC D21/419, 421, 423, 426-428, 435, 760,
D21/765, 771; D12/1, 8, 108, 112, 113
CPC . B62K 3/002; B62K 9/00; B62K 9/02; B62K
13/00; B62K 2202/00; B62K 11/00;
B62K 11/02; B62K 11/06; B62K 11/10;
B62K 15/00; B62K 17/00; H04W 4/40
See application file for complete search history.

(56) **References Cited**

U.S. PATENT DOCUMENTS

7,976,035 B2 * 7/2011 Chan B62K 15/00
280/87.05
D654,963 S * 2/2012 Powers D21/423

D692,963 S * 11/2013 Radtke D21/423
D717,881 S * 11/2014 Radtke D21/423
D806,176 S * 12/2017 Peng D21/423
D815,215 S * 4/2018 Desberg D21/423
D834,097 S * 11/2018 Lin D21/423
D837,303 S * 1/2019 Desberg D21/423
D839,358 S * 1/2019 Cao D21/423
D855,115 S * 7/2019 Yan D21/423
2013/0087983 A1 * 4/2013 Ngai B60B 19/00
280/87.041
2017/0240239 A1 * 8/2017 Huang B62K 3/002
2019/0263468 A1 * 8/2019 Huang B62K 3/002

* cited by examiner

Primary Examiner — Cynthia M. Chin

(74) *Attorney, Agent, or Firm* — Locke Lord LLP; Tim
Tingkang Xia, Esq.

(57) **CLAIM**

The ornamental design for a scooter, as shown and
described.

DESCRIPTION

FIG. 1 is a first perspective view of a scooter according to
my new design;
FIG. 2 is a right side elevation view thereof;
FIG. 3 is a left side elevation view thereof;
FIG. 4 is a front elevation view thereof;
FIG. 5 is a rear elevation view thereof;
FIG. 6 is a top plan view thereof; and,
FIG. 7 is a bottom plan view thereof.
The broken lines are for the purpose of illustrating portions
of the scooter that form no part of the claimed design.

1 Claim, 7 Drawing Sheets

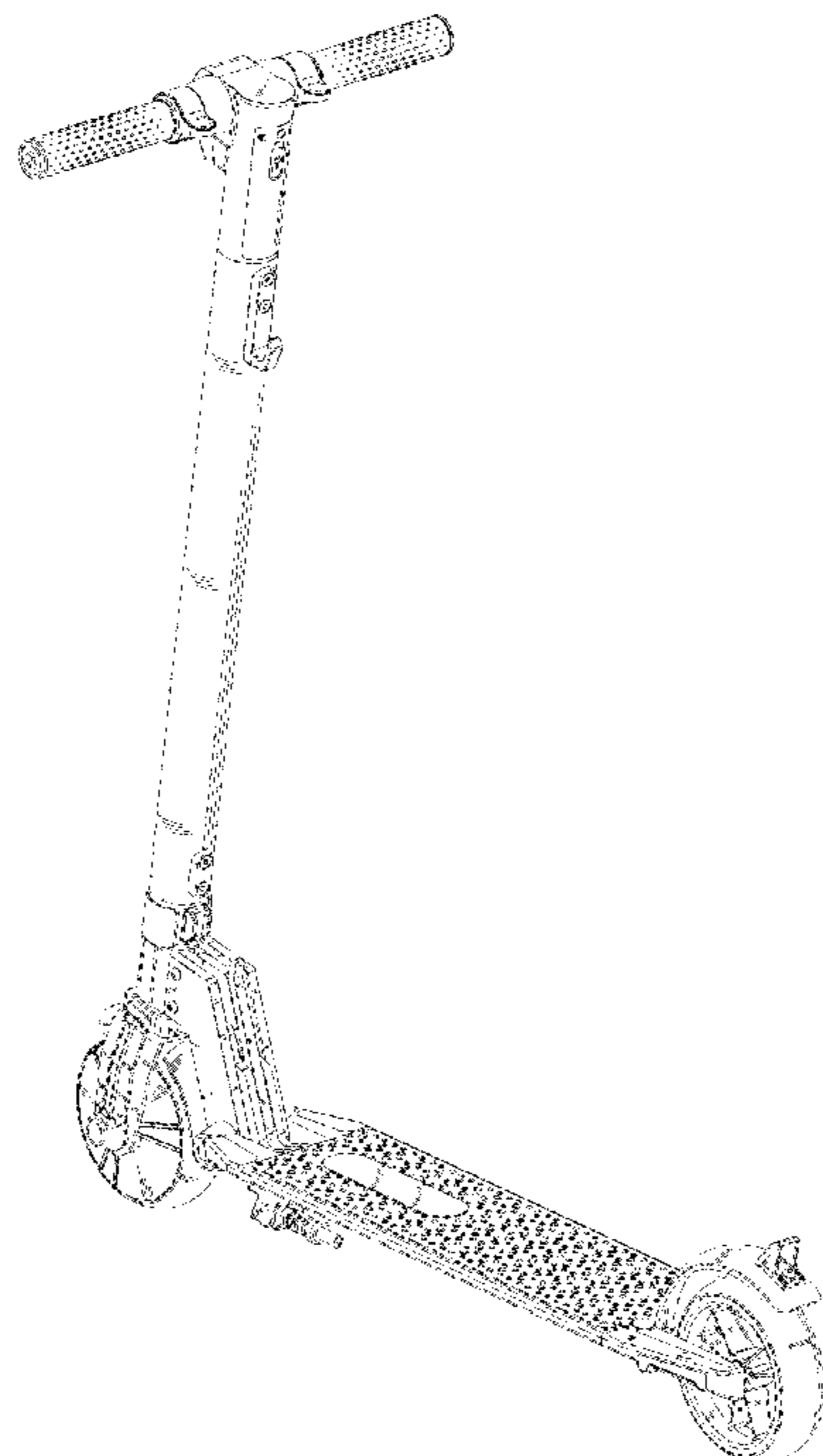

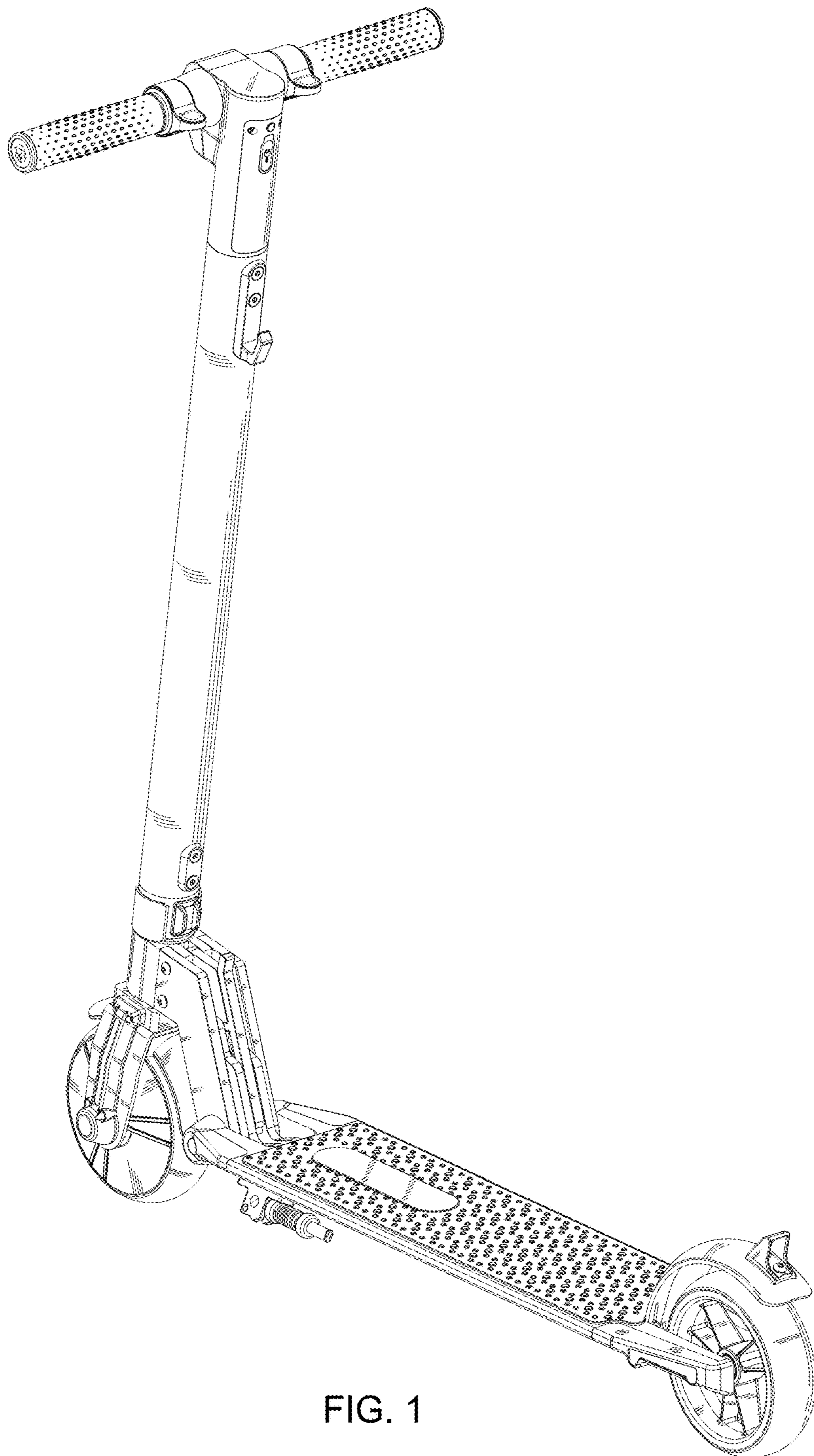

FIG. 1

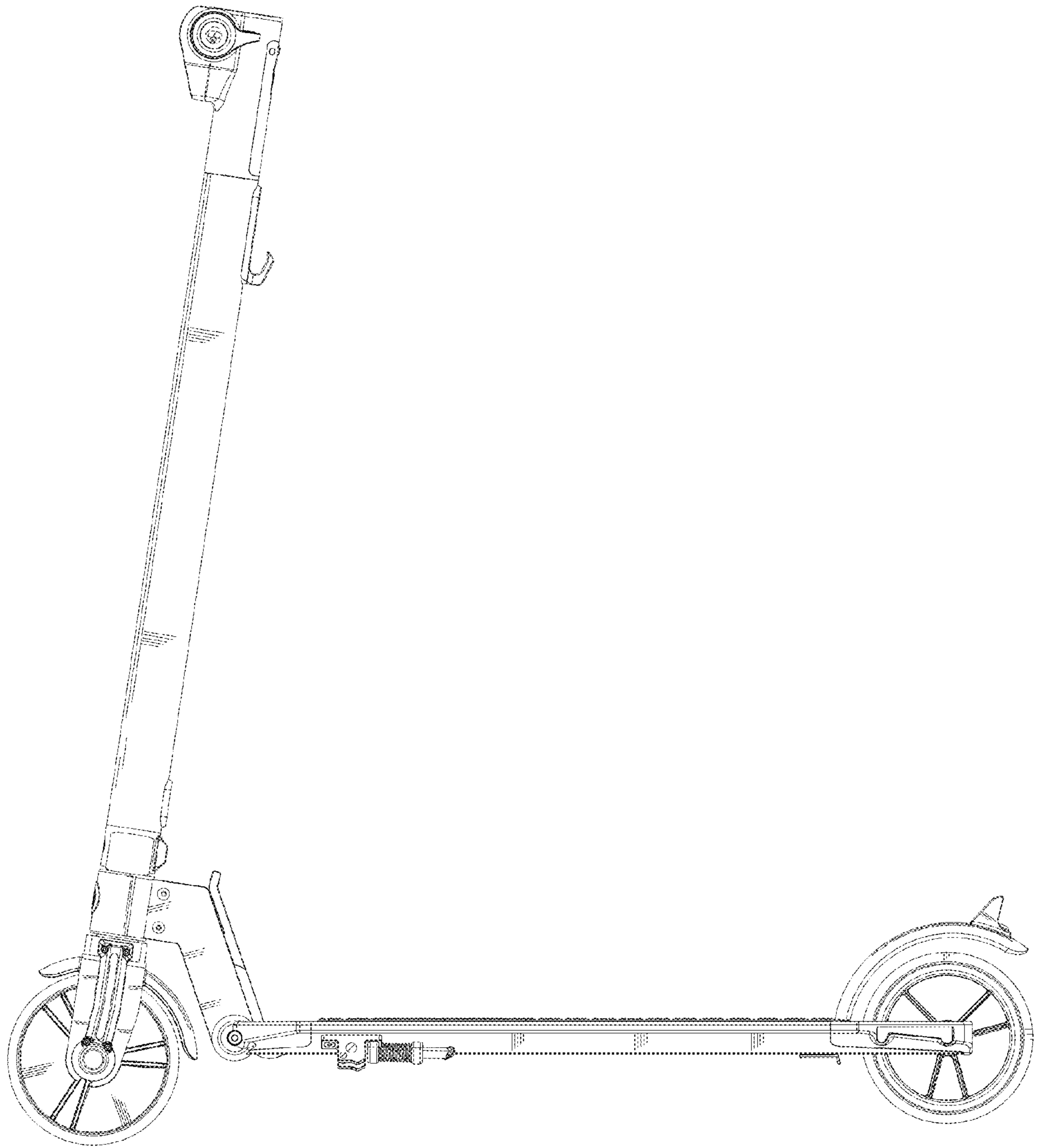

FIG. 2

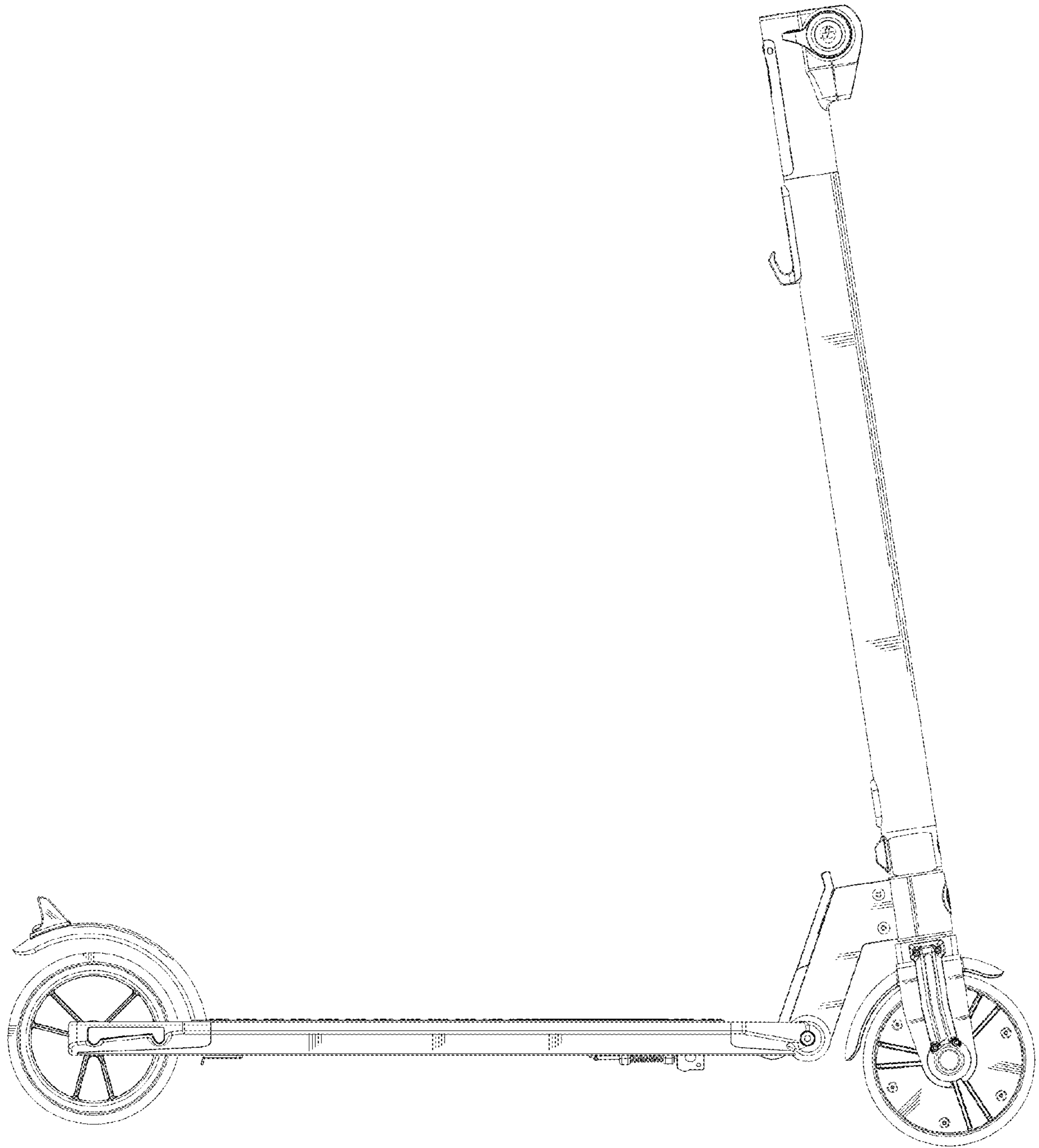

FIG. 3

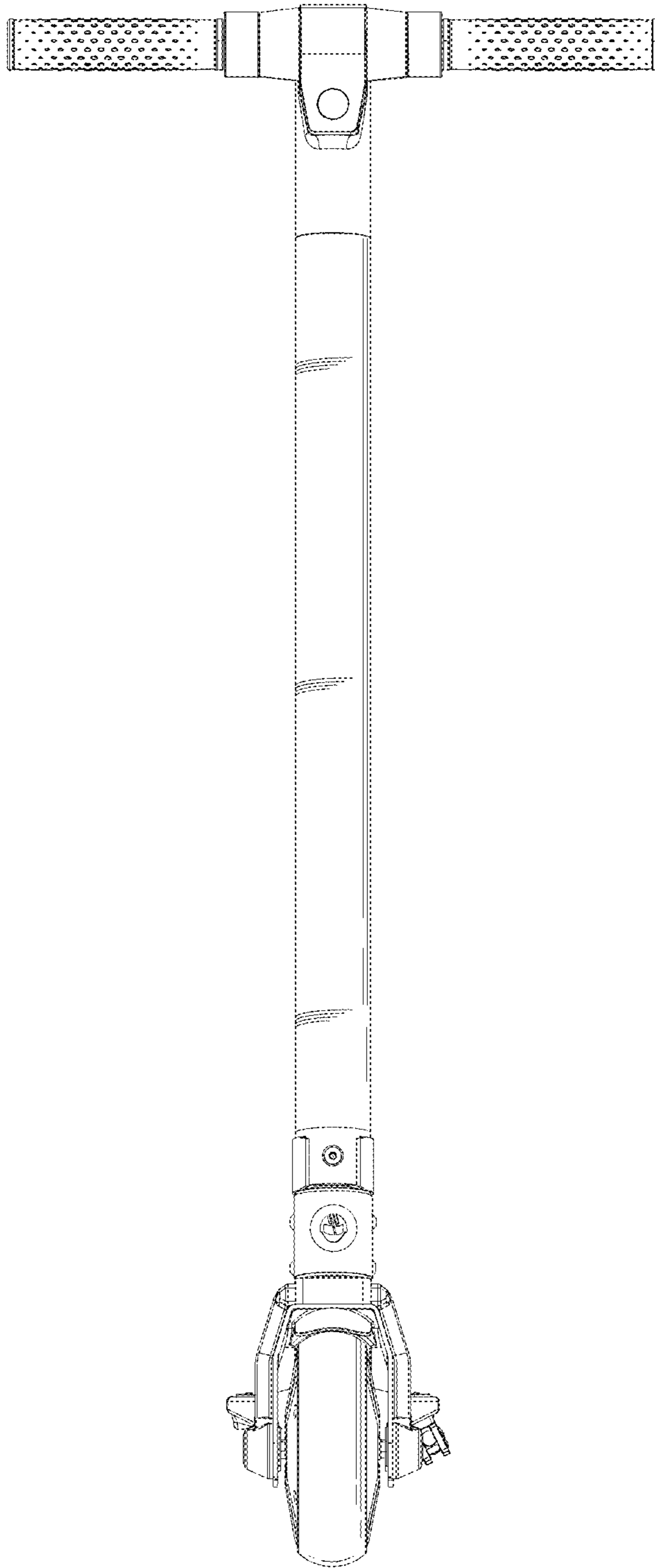

FIG. 4

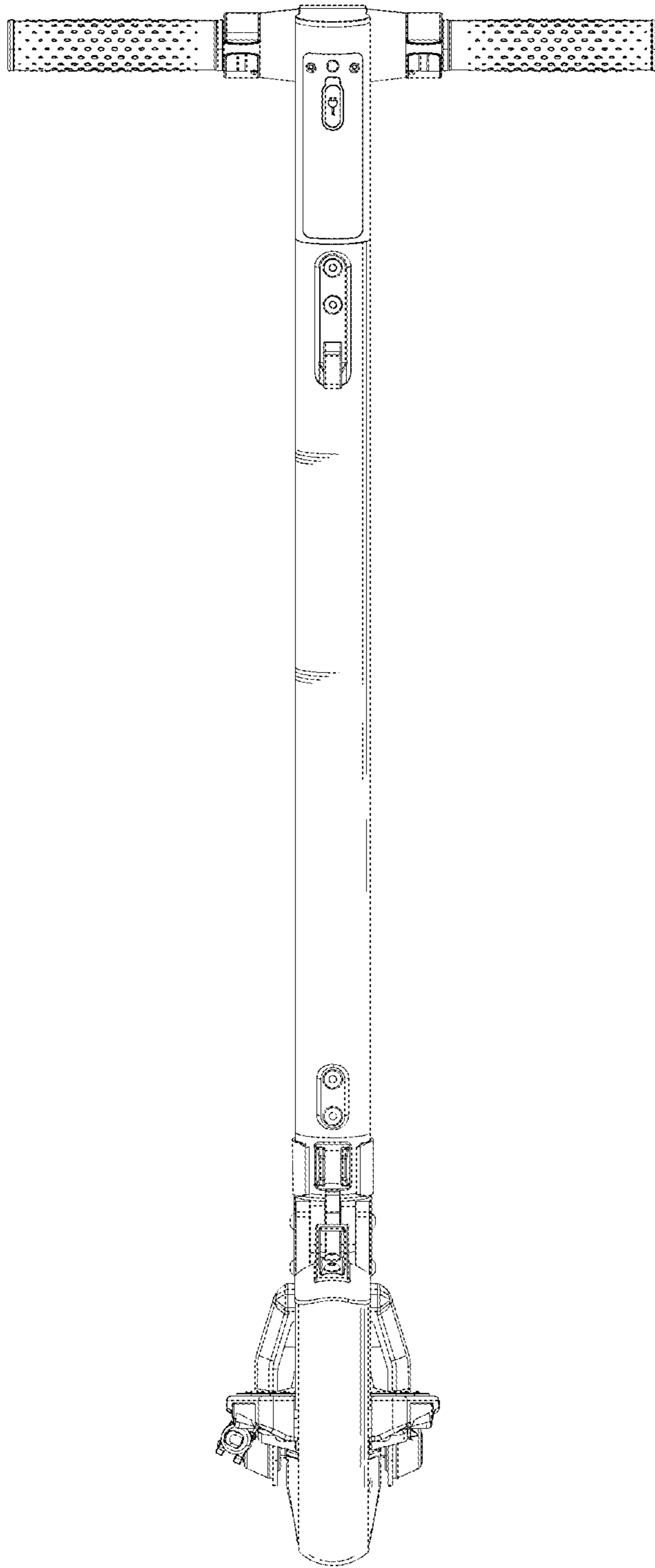

FIG. 5

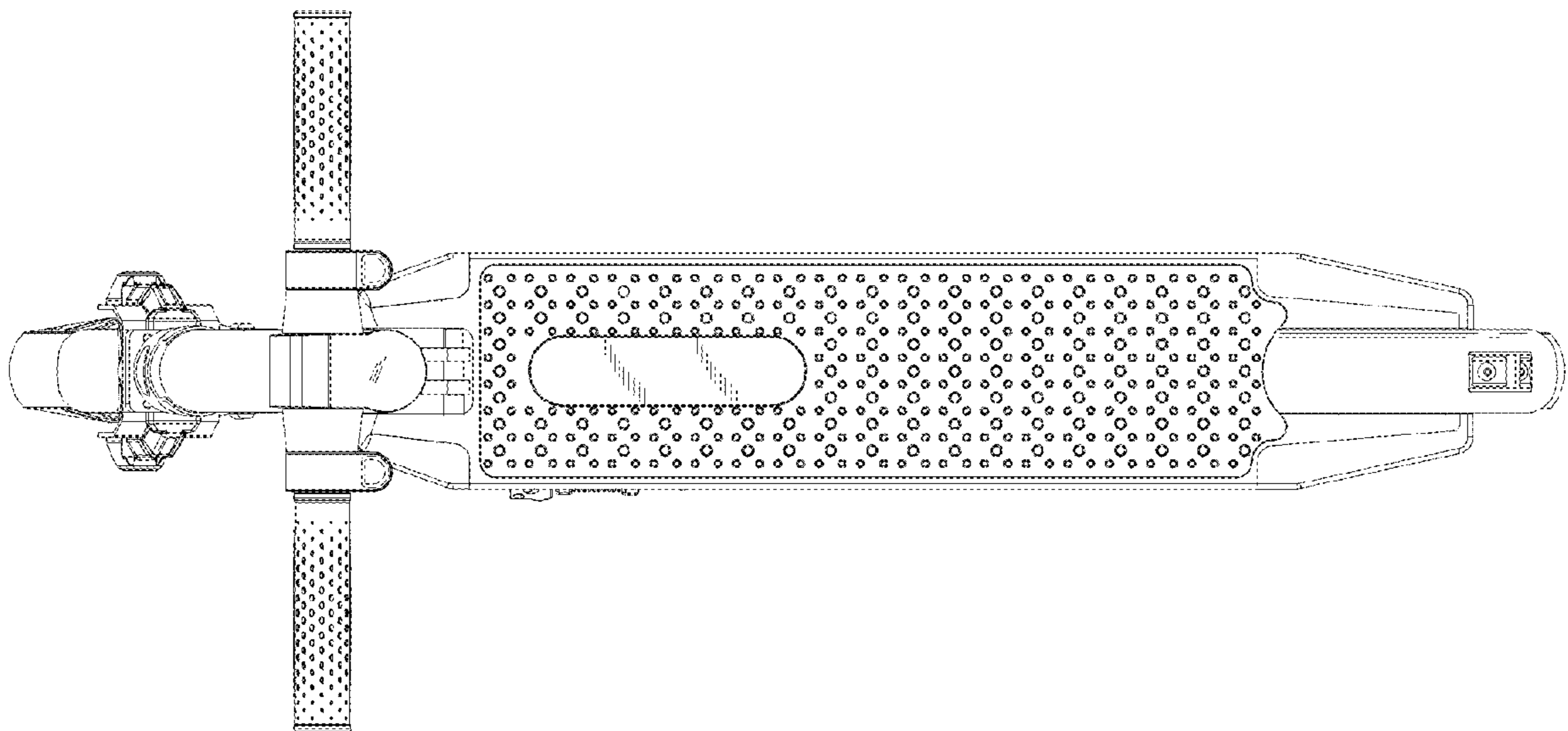

FIG. 6

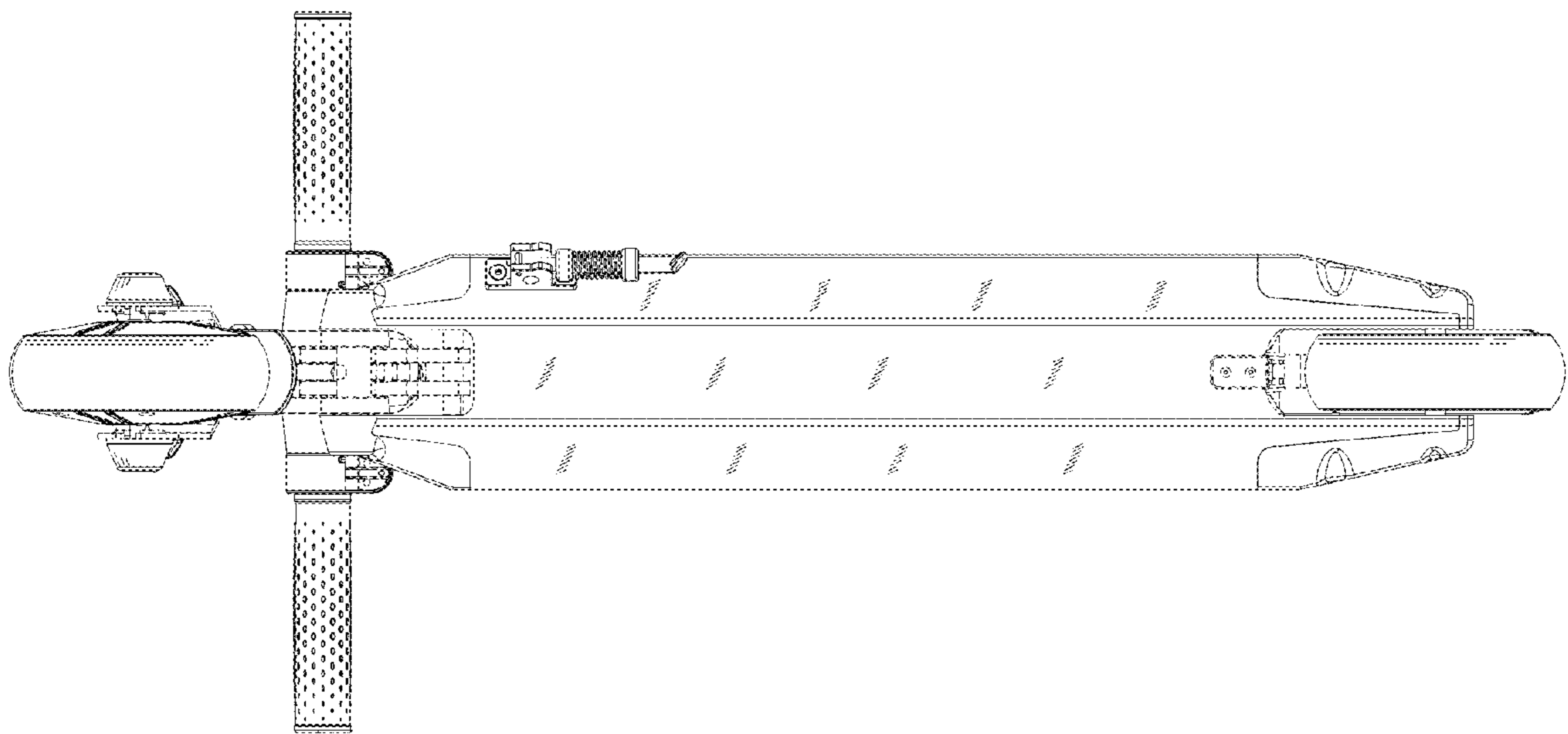

FIG. 7