



US00D877200S

(12) **United States Design Patent** (10) **Patent No.:** **US D877,200 S**
Melde et al. (45) **Date of Patent:** **** Mar. 3, 2020**

(54) **CRANKCASE VENTILATION DEVICE HOUSING**

(71) Applicant: **MANN+HUMMEL GmbH**,
Ludwigsburg (DE)

(72) Inventors: **Markus Melde**, Speyer (DE); **Markus Zuerker**, Dudenhofen (DE); **Shamantha Mn**, Karnataka (DE); **Peter Theiss**, Stuttgart (DE); **Florian Bentele**, Deckenpfronn (DE)

(73) Assignee: **MANN+HUMMEL GmbH**,
Ludwigsburg (DE)

(**) Term: **15 Years**

(21) Appl. No.: **29/614,798**

(22) Filed: **Aug. 23, 2017**

(30) **Foreign Application Priority Data**

Feb. 27, 2017 (EM) 003771096-0001

(51) **LOC (12) Cl.** **15-01**

(52) **U.S. Cl.**
USPC **D15/5; D13/122**

(58) **Field of Classification Search**
USPC D13/112, 110, 113, 114, 118, 119, 122,
D13/199; D15/1, 5, 199; 290/36 R,
290/38 R, 39; 310/10, 20, 40 R, 40 MM,
310/42, 68 D, 75 R, 80, 83, 88, 89, 98,
310/109, 114
CPC H02K 5/06; H02K 5/225; H02K 11/33;
H02K 9/14; H02K 7/1025; H02K
7/20918; H01R 39/381; H02M 5/272;
F01M 13/00; F01M 13/04; F01M 13/022;
F01M 13/023; F01M 13/028; F01M
13/0416; F02B 37/00; B01D 46/24; B01D
46/52

See application file for complete search history.

(56) **References Cited**

U.S. PATENT DOCUMENTS

D136,503	S	*	10/1943	Heintz	D13/113
D336,282	S	*	6/1993	Guginsky	D13/133
6,171,355	B1	*	1/2001	Gieseke	B01D 46/001 55/330
D595,739	S	*	7/2009	Ogawa	D15/5
D619,149	S	*	7/2010	Aketa	D15/5
D727,970	S	*	4/2015	Peterson	D15/5
D758,314	S	*	6/2016	Shanahan	D13/146

OTHER PUBLICATIONS

Prevent 200 , May 2, 2016 <https://www.amazon.com/Mann-Hummel-6257511-Provent-200/dp/B01F2NZ6RQ>.*

* cited by examiner

Primary Examiner — Derrick E Holland

(74) *Attorney, Agent, or Firm* — James Hasselbeck

(57) **CLAIM**

We claim the ornamental design for a crankcase ventilation device housing, as shown and described.

DESCRIPTION

FIG. 1 shows a left front perspective view of a crankcase ventilation device housing showing our new design; FIG. 2 shows a left side elevational view thereof; FIG. 3 shows a right side elevational view thereof; FIG. 4 shows a front elevational view thereof; FIG. 5 shows a rear elevational view thereof; FIG. 6 shows a top plan view thereof; and, FIG. 7 shows a bottom plan view thereof. The broken lines illustrate the portions of the crankcase ventilation device housing that forms no part of the claimed design.

1 Claim, 6 Drawing Sheets

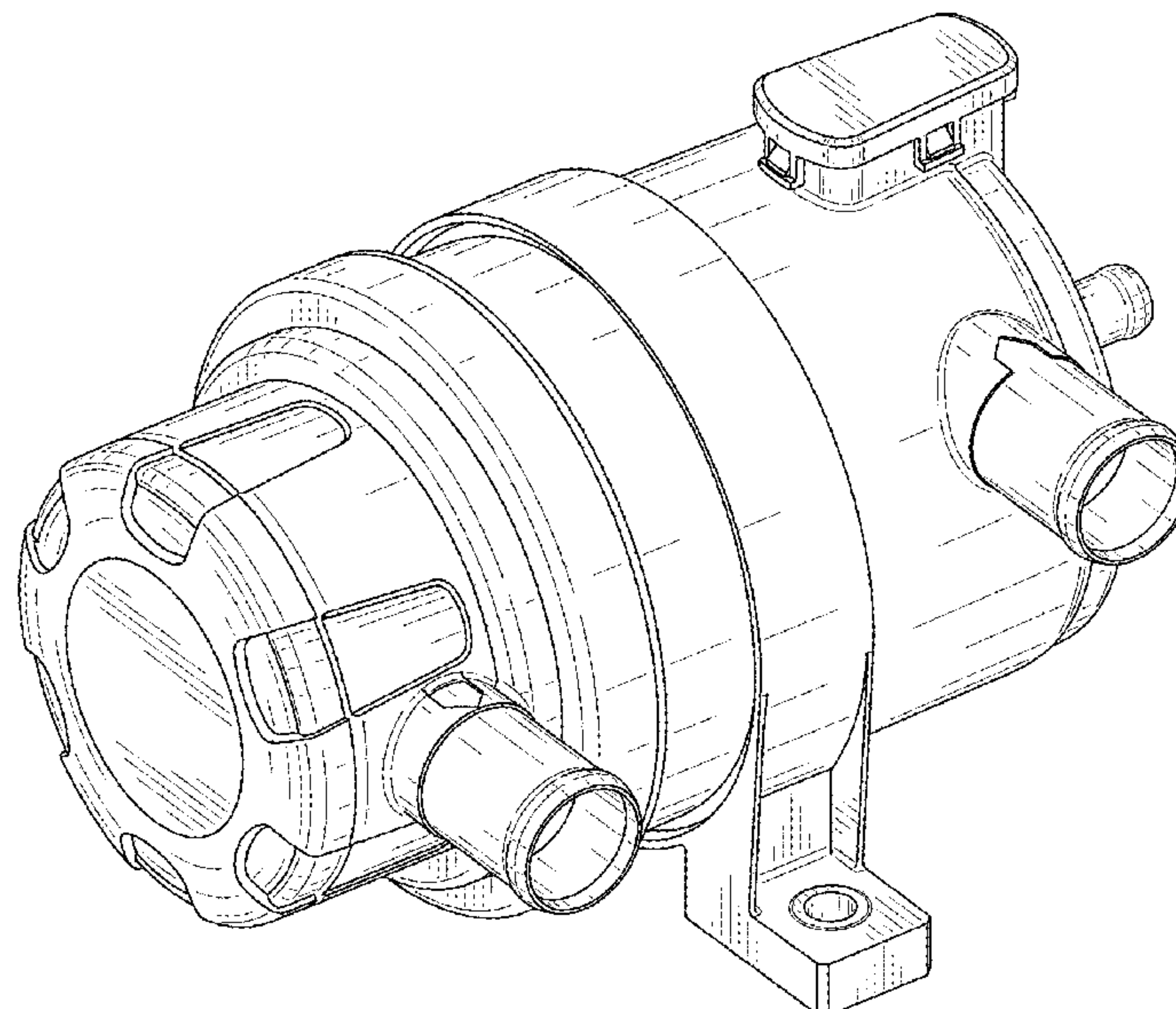

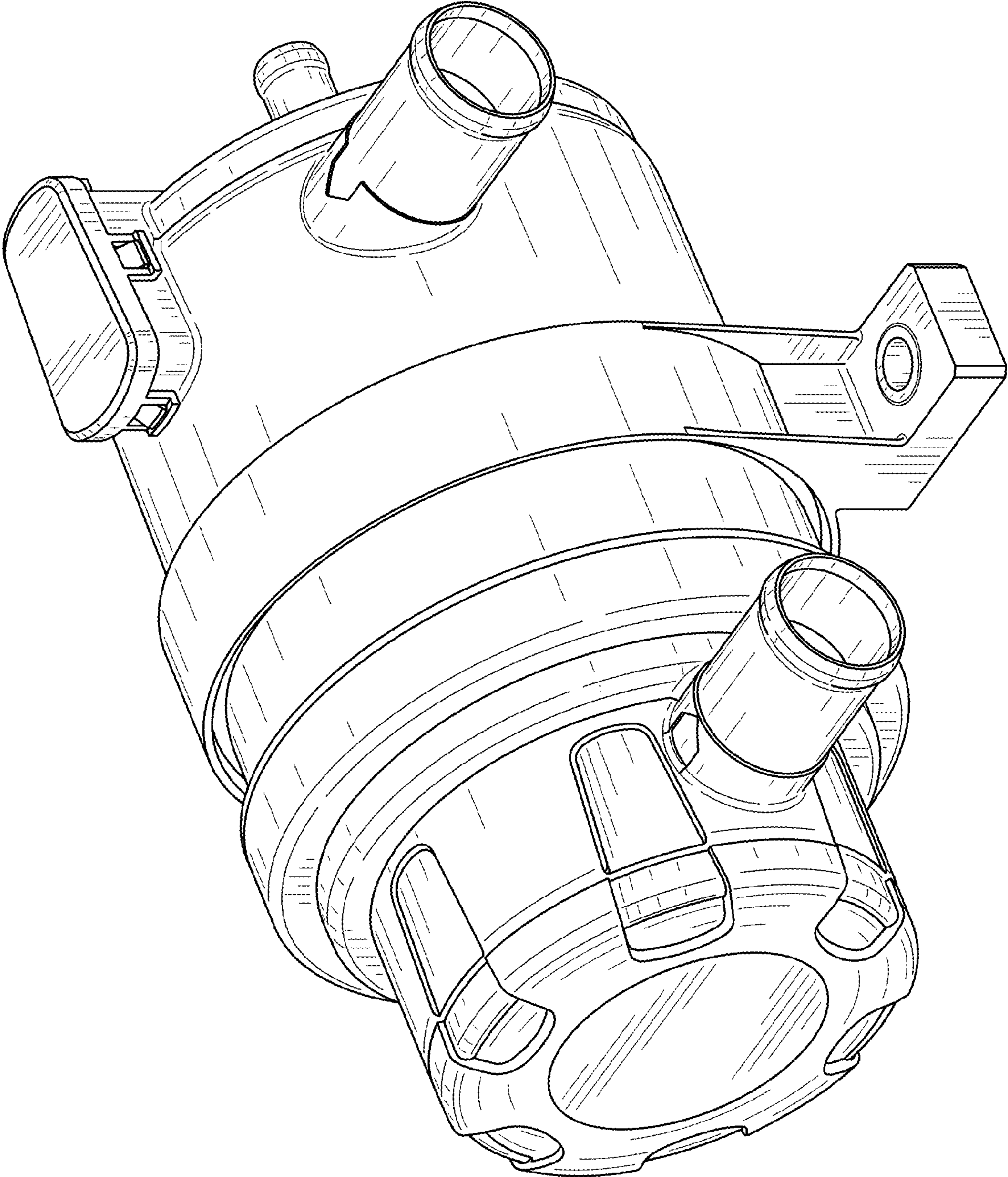

FIG. 1

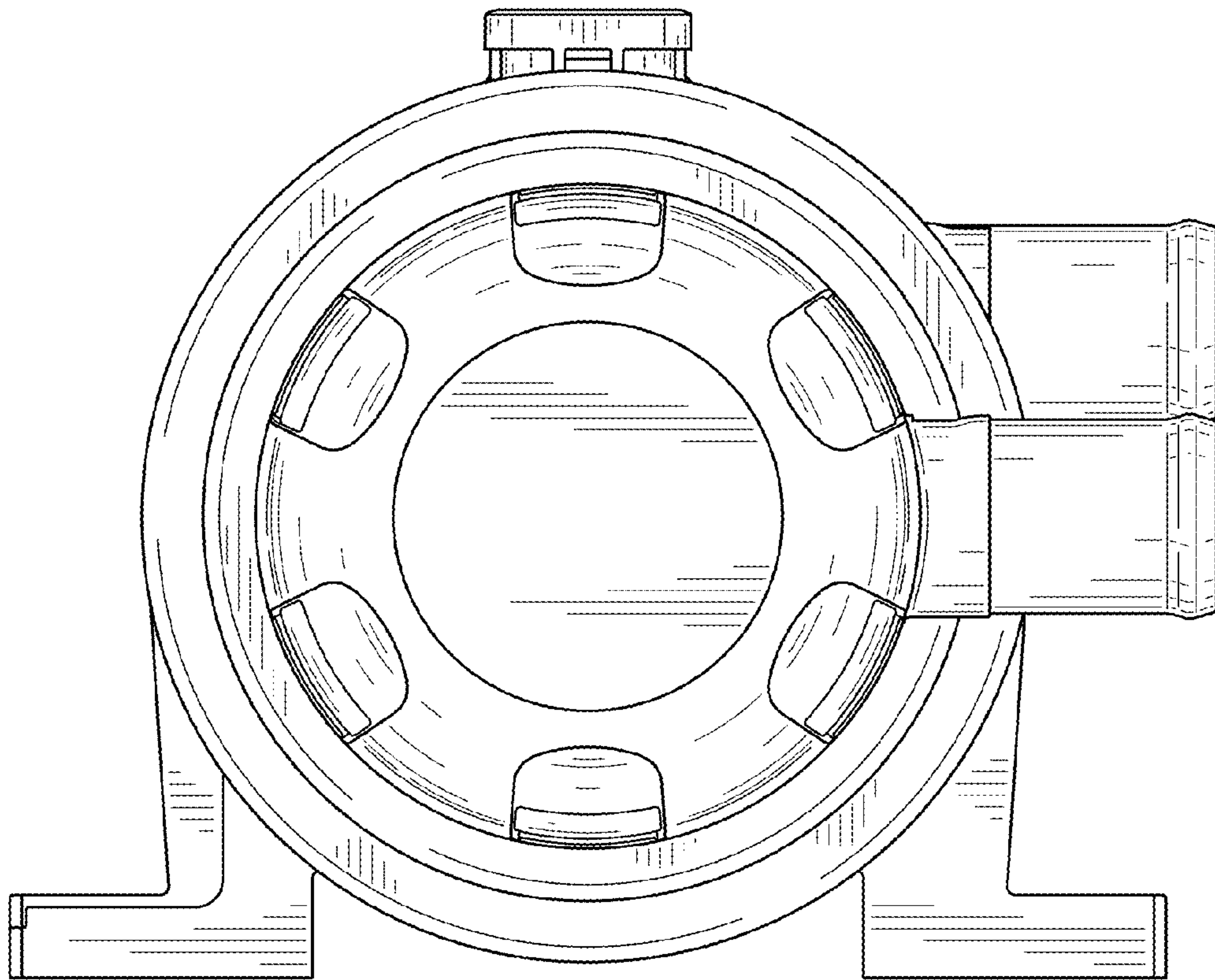

FIG. 2

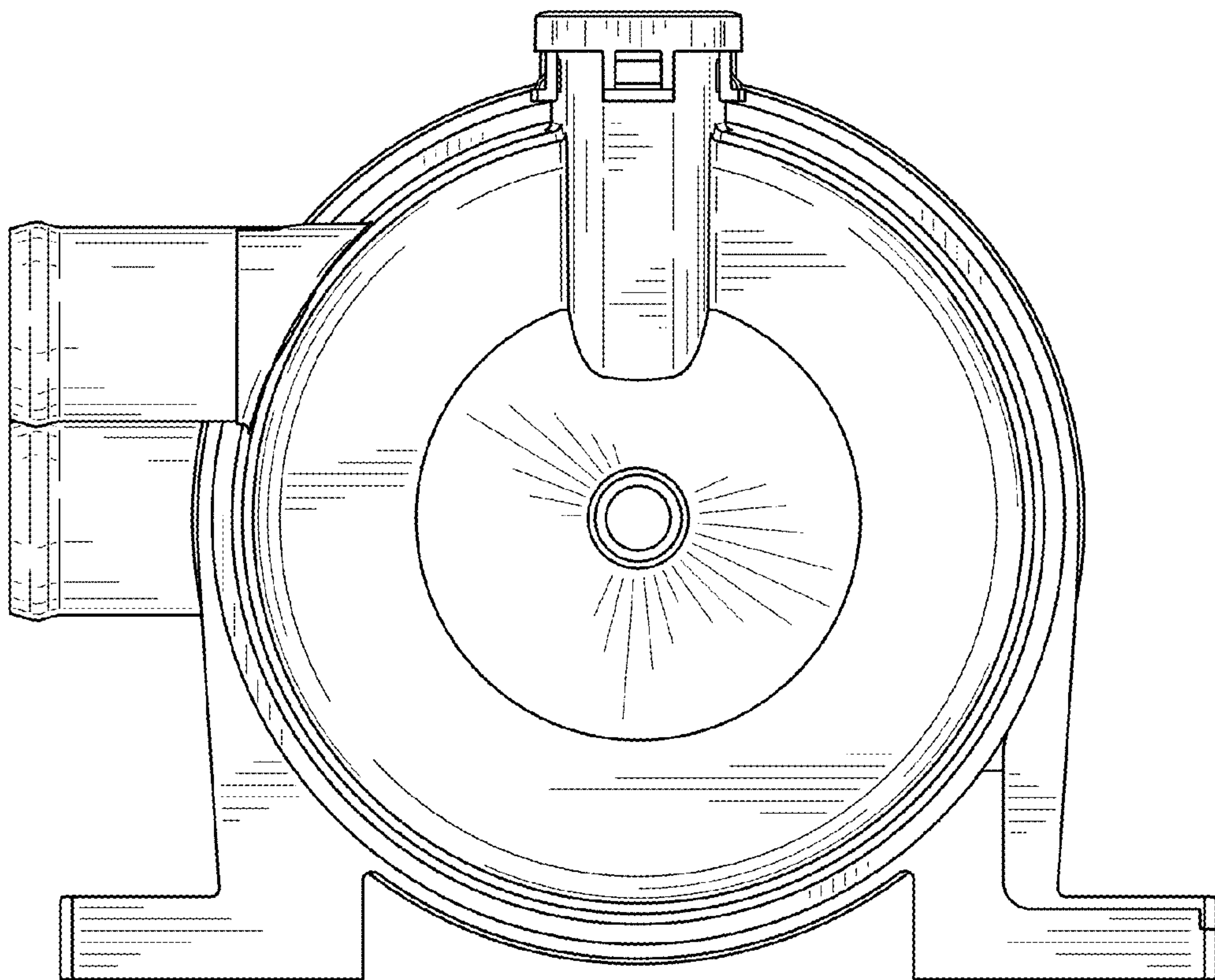

FIG. 3

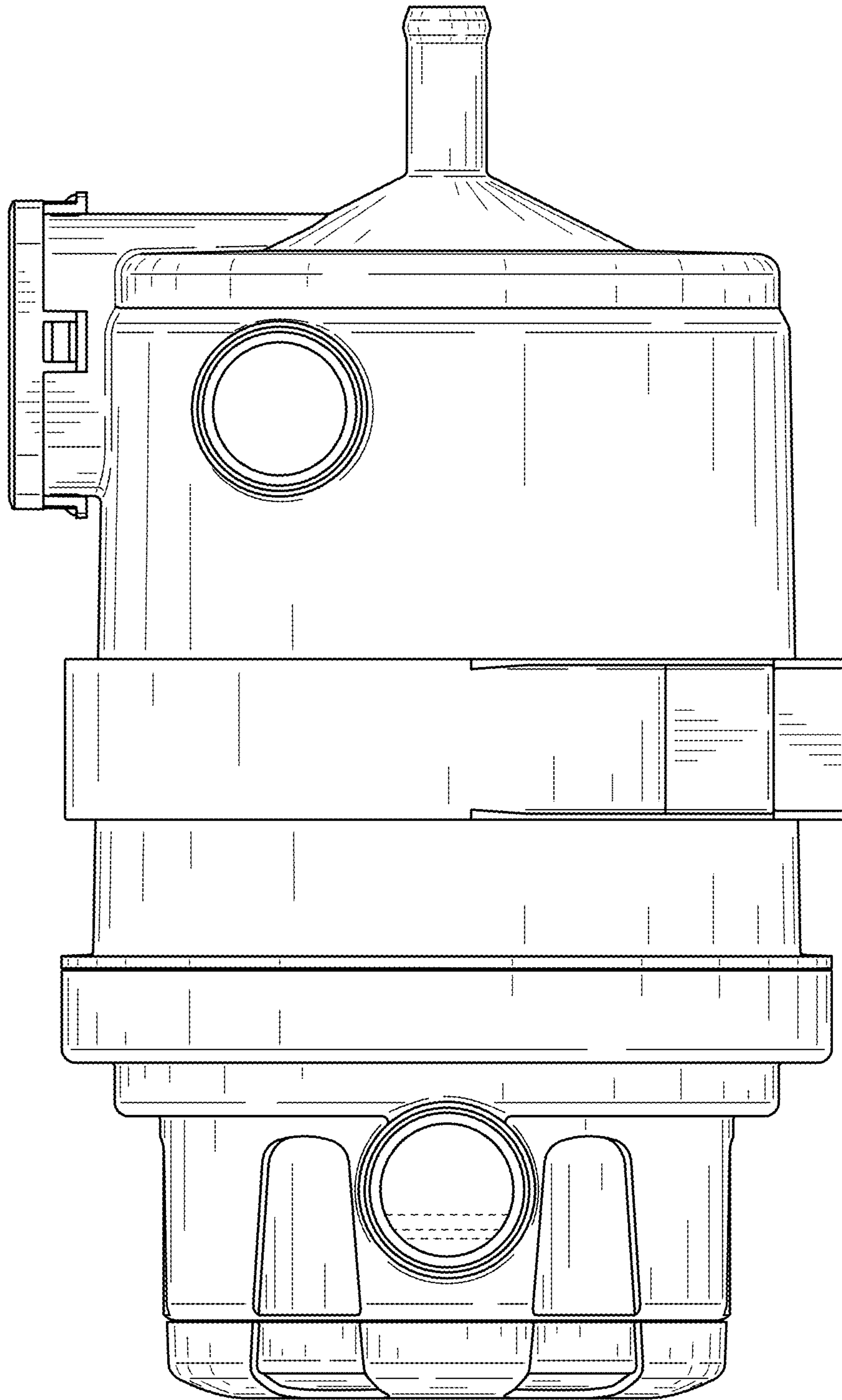

FIG. 4

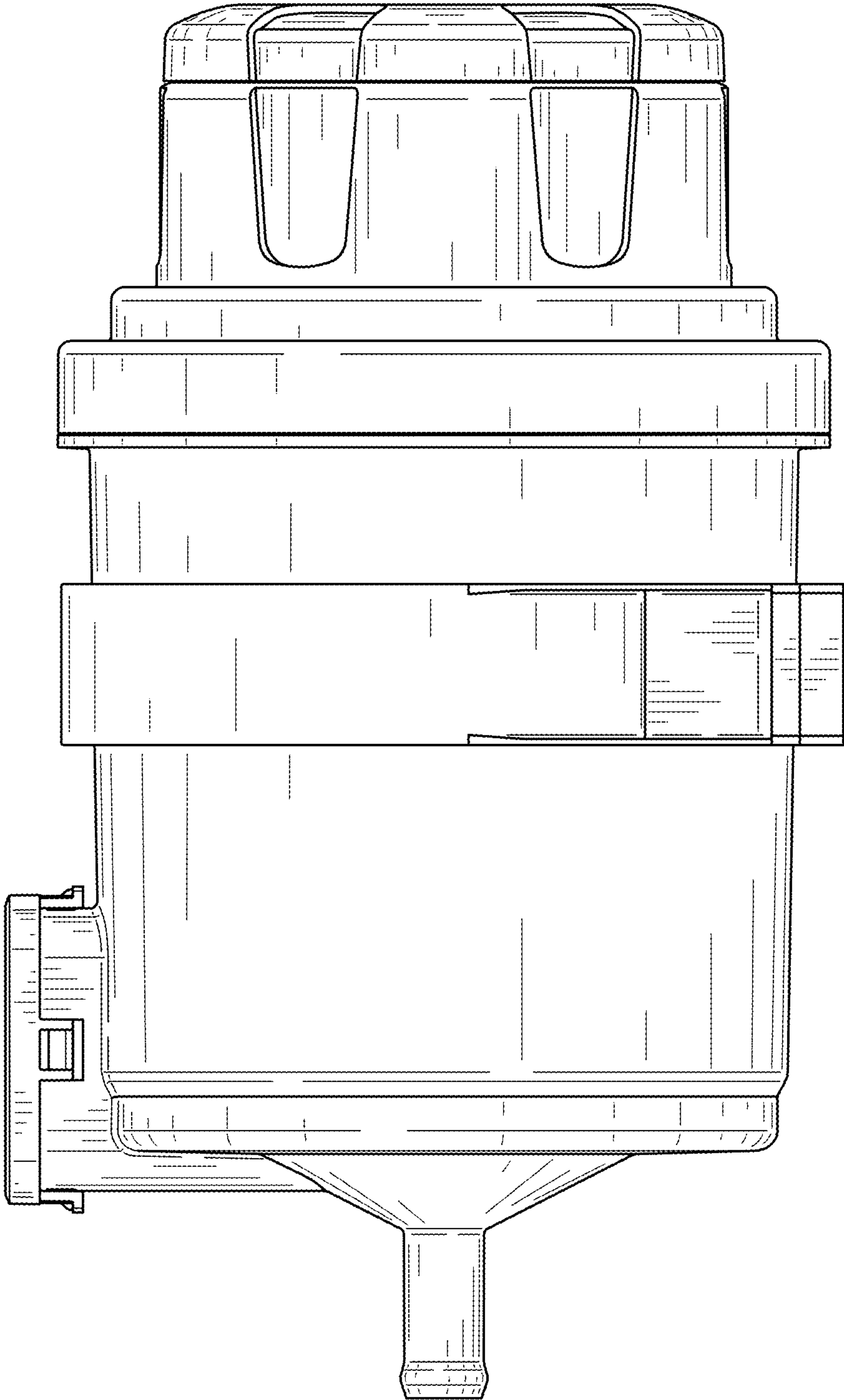

FIG. 5

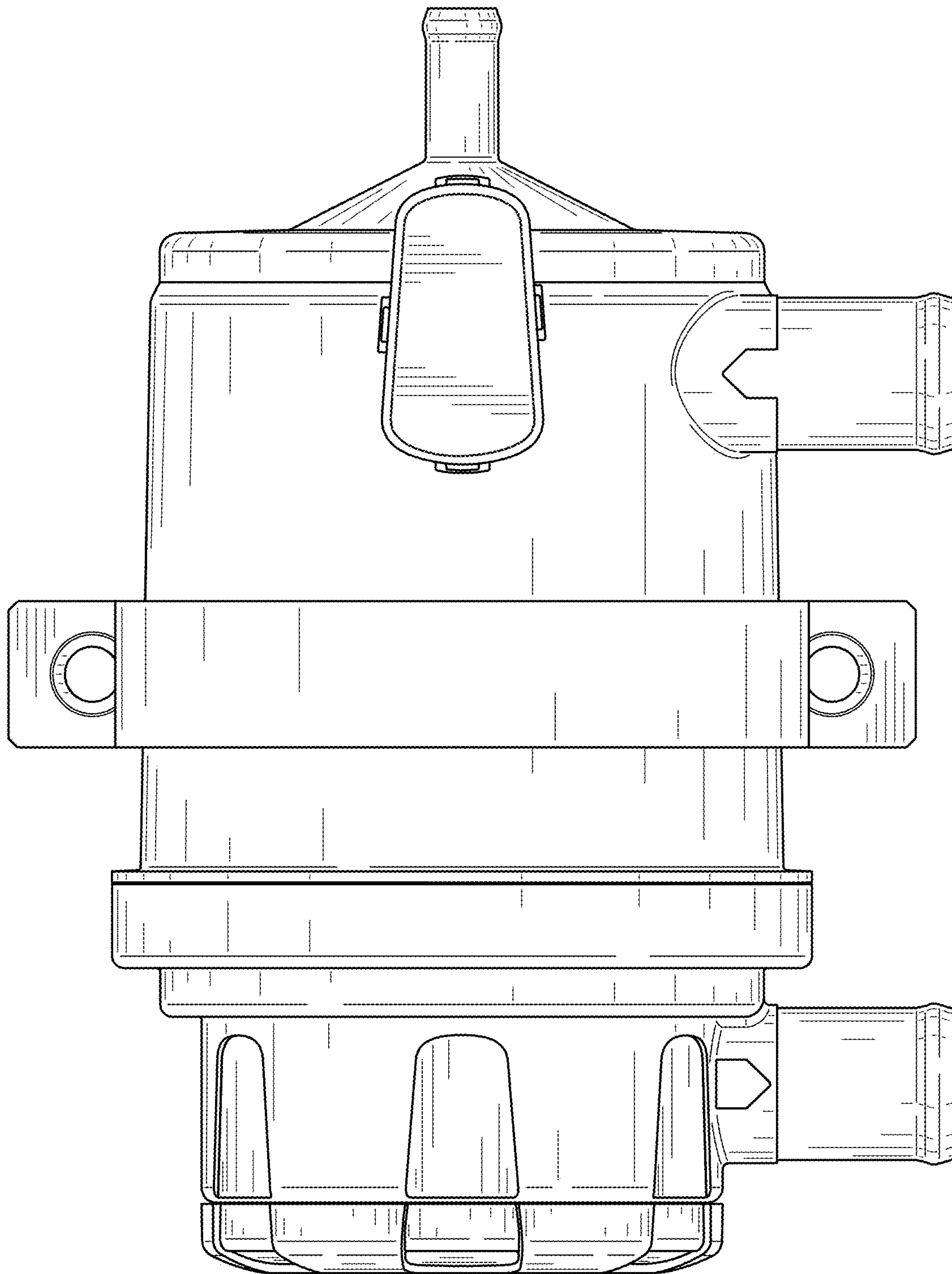

FIG. 6

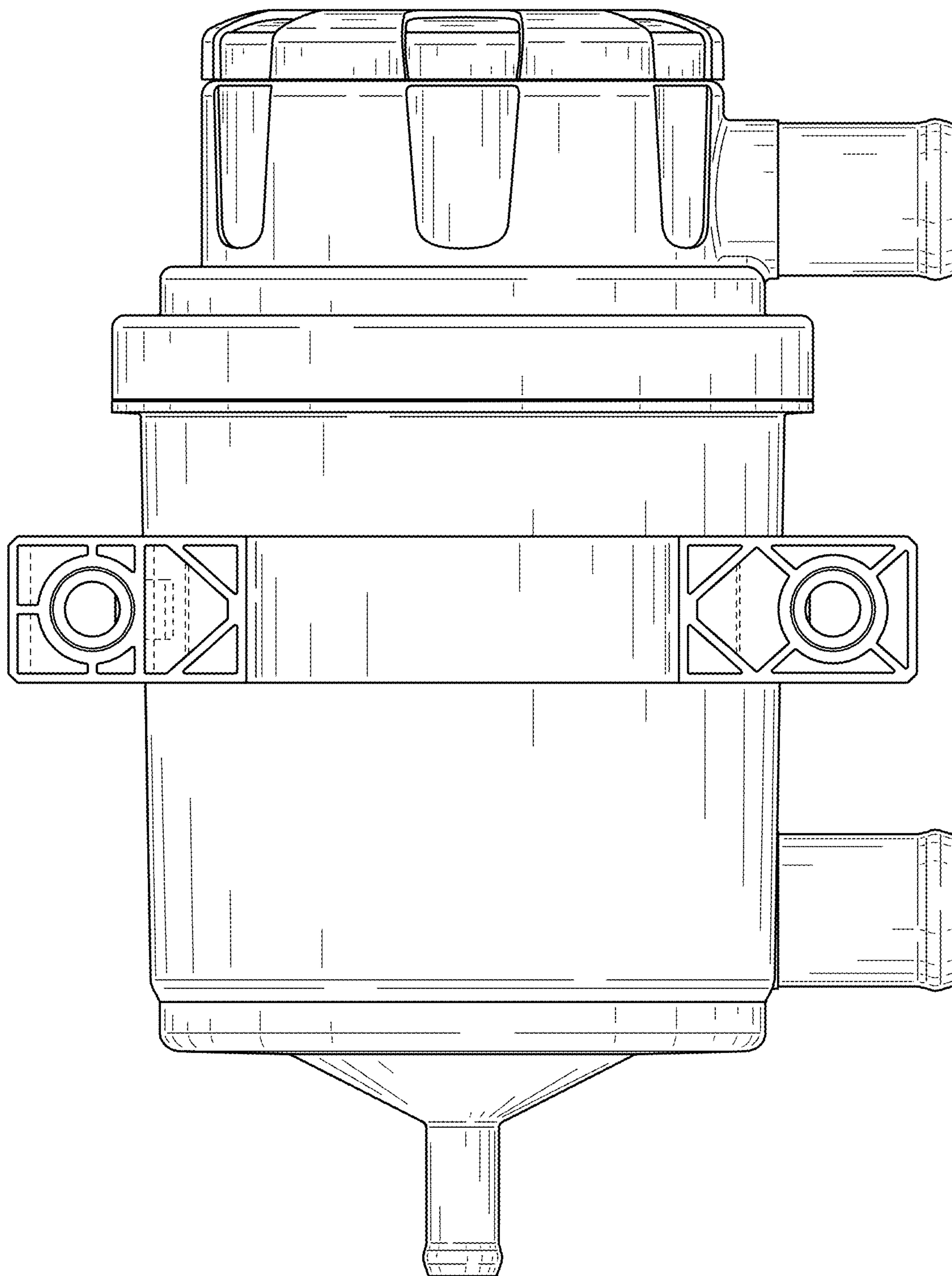

FIG. 7