



US00D876994S

(12) **United States Design Patent** (10) **Patent No.:** **US D876,994 S**
Collins et al. (45) **Date of Patent:** **** *Mar. 3, 2020**

(54) **DISPLAY HOUSING**

(71) Applicant: **DEKA Products Limited Partnership**,
Manchester, NH (US)

(72) Inventors: **David E. Collins**, Amesbury, MA (US);
Katie A. DeLaurentis, Manchester, NH
(US); **Alexander D. Streeter**, Concord,
NH (US)

(73) Assignee: **DEKA Products Limited Partnership**,
Manchester, NH (US)

(*) Notice: This patent is subject to a terminal dis-
claimer.

(**) Term: **15 Years**

(21) Appl. No.: **29/688,319**

(22) Filed: **Apr. 19, 2019**

Related U.S. Application Data

(63) Continuation of application No. 29/604,817, filed on
May 20, 2017, now Pat. No. Des. 846,452.

(51) **LOC (12) Cl.** **12-12**

(52) **U.S. Cl.**
USPC **D12/133; D14/388**

(58) **Field of Classification Search**

USPC D12/128–133, 274, 277, 415, 345;
D14/388, 389, 390, 318, 341, 342, 346,
D14/356, 130, 218, 454, 455, 299, 371,
D14/374, 378, 496, 432, 434, 457, 458,
D14/412, 413, 439, 440, 447, 448;
D13/162, 162.1, 136, 164, 168; D10/46,
D10/61, 65; D19/59–61, 113; D20/10,
D20/11, 19, 99; D21/324, 329, 333
CPC G06F 3/041; G06F 3/0412; G06F 3/0414;
G06F 3/0416; G06F 3/044; G06F 3/048;
G06F 3/484; G06F 3/488; G06F 3/4883;
G06F 3/03545; G06F 2203/0338; G06F

(Continued)

(56) **References Cited**

U.S. PATENT DOCUMENTS

584,127 A 6/1897 Draullette et al.
849,270 A 4/1907 Schafer

(Continued)

FOREIGN PATENT DOCUMENTS

CA 2580632 3/2006
CA 2822729 3/2006

(Continued)

OTHER PUBLICATIONS

D-r-net_CJSM2-400x280. magicmobility.com.au. [online img] 1
pg. Uploaded Nov. 2013. [Retrieved on Aug. 15, 2018] https://www.magicmobility.com.au/wp-content/uploads/2013/11/D-r-net_CJSM2-400x280.jpg.*

(Continued)

Primary Examiner — Marie D. Fast Horse

(74) *Attorney, Agent, or Firm* — Kathleen Chapman

(57) **CLAIM**

The ornamental design for a display housing, as shown and
described.

DESCRIPTION

FIG. 1 is a front, top, right side perspective view of the
display housing, showing our new design;
FIG. 2 is a top plan view thereof;
FIG. 3 is a bottom plan view thereof; and
FIG. 4 is a right side elevational view thereof;
FIG. 5 is a left side elevational view thereof;
FIG. 6 is a rear side elevational view thereof;
FIG. 7 is a front side elevational view thereof; and,
FIG. 8 is a front, top, right perspective view of the display
housing, shown in its environment.
The features shown in broken lines depict environmental
structure only and form no part of the claimed design.

1 Claim, 8 Drawing Sheets

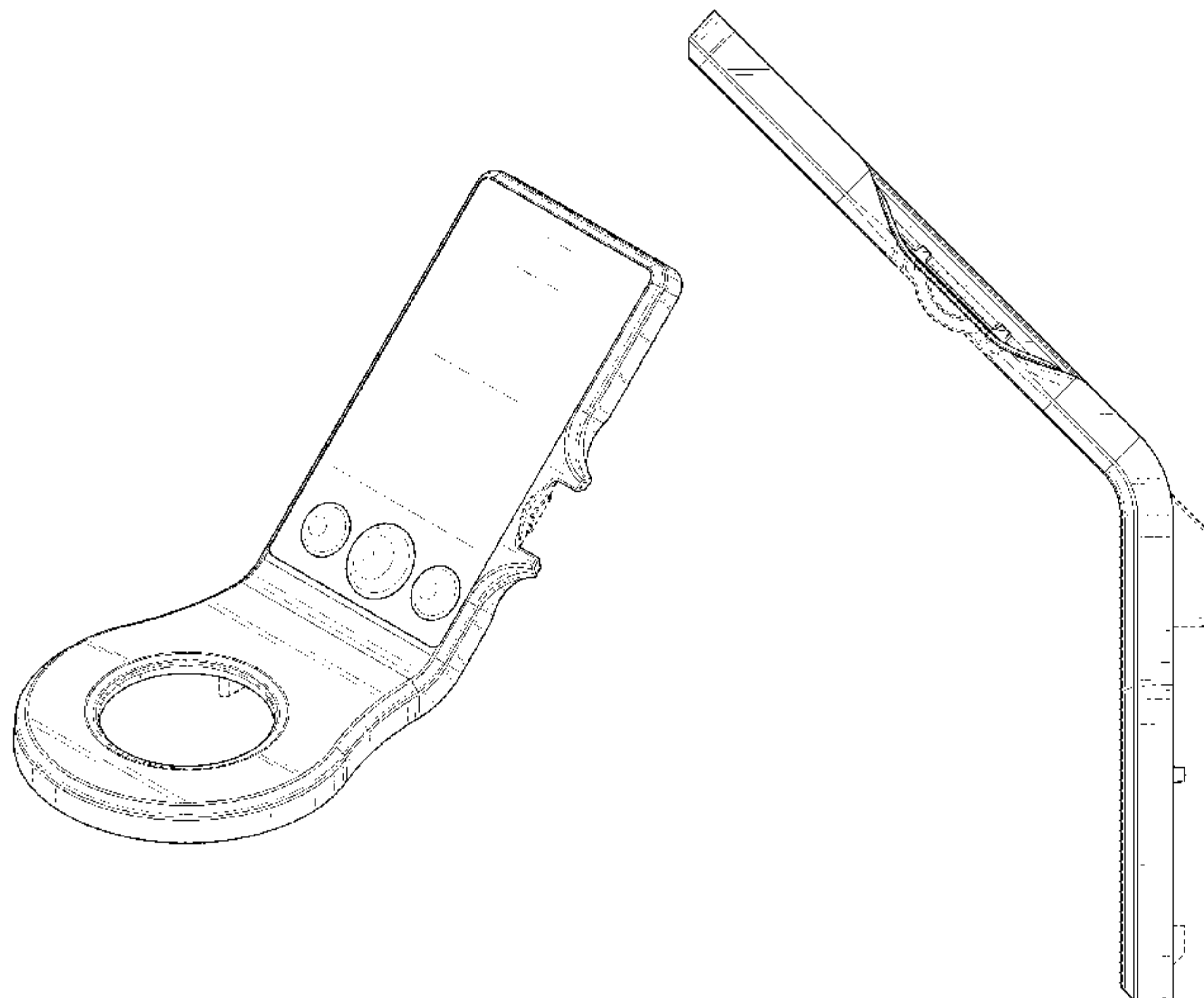

(58) **Field of Classification Search**
 CPC 1/1669; G06F 1/1643; G06F 1/166; A61G
 5/00-14
 See application file for complete search history.

(56) **References Cited**

U.S. PATENT DOCUMENTS

880,823 A 3/1908 Redfield
 2,224,411 A 12/1940 Smith
 2,415,056 A 1/1947 Wheeler
 2,618,447 A 11/1952 Lecarme
 2,742,973 A 4/1956 Johannesen
 2,966,223 A 12/1960 Gleasman
 3,017,199 A 1/1962 Sechrist
 3,145,797 A 8/1964 Taylor
 3,179,355 A 4/1965 Pickering
 3,260,324 A 7/1966 Suarez
 3,283,398 A 11/1966 Andren
 3,288,234 A 11/1966 Feliz
 3,306,626 A 2/1967 Kawada
 3,313,365 A 4/1967 Jackson
 3,338,328 A 8/1967 Cataldo
 3,348,518 A 10/1967 Forsyth
 3,374,845 A 3/1968 Selwyn
 3,399,742 A 9/1968 Malick
 3,446,304 A 5/1969 Alimanestiand
 3,450,219 A 6/1969 Fleming
 3,515,401 A 6/1970 Gross
 3,580,344 A 5/1971 Floyd
 3,596,298 A 8/1971 Durst, Jr.
 3,628,624 A 12/1971 Wesener
 3,718,342 A 2/1973 Freed
 3,787,066 A 1/1974 Hautier
 3,790,150 A 2/1974 Lippert
 3,860,264 A 1/1975 Douglas
 3,872,945 A 3/1975 Hickman
 3,893,689 A 7/1975 Verhoff
 3,952,822 A 4/1976 Udden
 3,965,402 A 6/1976 Mogle
 3,993,154 A 11/1976 Simmons et al.
 4,005,907 A 2/1977 Bonomo
 4,018,440 A 4/1977 Deutsch
 4,030,753 A 6/1977 Meiners
 4,054,319 A 10/1977 Fogg et al.
 4,062,558 A 12/1977 Wasserman
 4,065,145 A 12/1977 Chambers
 4,065,146 A 12/1977 Denzer
 4,076,270 A 2/1978 Winchell
 4,078,627 A 3/1978 Brown et al.
 4,087,107 A 5/1978 Winchell
 4,088,199 A 5/1978 Trautwein
 4,094,372 A 6/1978 Notter
 4,109,741 A 8/1978 Gabriel
 4,111,445 A 9/1978 Haibeck
 4,115,445 A 9/1978 Harsey
 4,140,200 A 2/1979 Tucek
 4,151,892 A 5/1979 Francken
 D253,234 S * 10/1979 Cooke D13/168
 4,222,449 A 9/1980 Feliz
 D258,958 S * 4/1981 Fukushima 14/53
 4,264,082 A 4/1981 Fouchey, Jr.
 4,266,627 A 5/1981 Lauber
 4,274,503 A 6/1981 Mackintosh
 4,281,734 A 8/1981 Johnston
 4,293,052 A 10/1981 Daswick
 4,307,788 A 12/1981 Shelton
 4,325,565 A 4/1982 Winchell
 4,354,569 A 10/1982 Eichholz
 D266,758 S * 11/1982 Johannsen D13/168
 4,363,493 A 12/1982 Veneklasen
 4,373,600 A 2/1983 Buschbom
 4,375,840 A 3/1983 Campbell
 4,413,693 A 11/1983 Derby
 4,448,455 A 5/1984 Ellegaard
 4,456,086 A 6/1984 Wier
 4,484,648 A 11/1984 Jephcott

4,510,956 A 4/1985 King
 4,512,588 A 4/1985 Cox
 4,556,997 A 12/1985 Takamiya
 4,560,022 A 12/1985 Kassai
 4,566,707 A 1/1986 Nitzberg
 4,570,078 A 2/1986 Yashima
 4,571,844 A 2/1986 Komasaku
 4,624,469 A 11/1986 Bourne, Jr.
 4,648,783 A 3/1987 Tan
 4,657,271 A 4/1987 Salmon
 4,657,272 A 4/1987 Davenport
 D290,382 S * 6/1987 Sawit D13/164
 4,685,693 A 8/1987 Vadjunec
 4,709,772 A 12/1987 Brunet
 4,712,806 A 12/1987 Patrin
 4,716,980 A 1/1988 Butler
 4,722,547 A 2/1988 Kishi
 4,732,353 A 3/1988 Studer
 4,740,001 A 4/1988 Torleumke
 4,746,132 A 5/1988 Eagan
 4,750,578 A 6/1988 Brandenfels
 4,770,410 A 9/1988 Brown
 4,778,133 A 10/1988 Sakurai
 4,786,069 A 11/1988 Tang
 4,787,679 A 11/1988 Arnold
 4,790,400 A 12/1988 Sheeter
 4,790,548 A 12/1988 Decelles
 4,794,730 A 1/1989 Fischbach
 4,794,999 A 1/1989 Hester
 4,798,255 A 1/1989 Wu
 4,802,542 A 2/1989 Houston
 4,809,804 A 3/1989 Houston
 4,834,200 A 5/1989 Kajita
 4,837,694 A 6/1989 Narita et al.
 4,863,182 A 9/1989 Chern
 4,867,188 A 9/1989 Reid
 4,869,279 A 9/1989 Hedges
 4,874,055 A 10/1989 Beer
 4,890,853 A 1/1990 Olson
 4,897,070 A 1/1990 Wagstaff
 4,913,252 A 4/1990 Bartley et al.
 4,919,225 A 4/1990 Sturges
 D308,364 S * 6/1990 Beasley, Jr. D14/389
 4,941,854 A 7/1990 Takahashi et al.
 4,944,360 A 7/1990 Sturges
 4,953,851 A 9/1990 Sherlock
 4,964,679 A 10/1990 Rath
 4,967,862 A 11/1990 Pong et al.
 4,973,071 A 11/1990 Ishizaki
 4,984,754 A 1/1991 Yarrington
 4,985,947 A 1/1991 Ethridge
 4,998,596 A 3/1991 Miksitz
 5,001,636 A 3/1991 Shiraishi et al.
 5,002,295 A 3/1991 Lin
 5,011,171 A 4/1991 Cook
 5,012,176 A 4/1991 Laforge
 RE33,675 E 8/1991 Young
 5,044,457 A 9/1991 Aikman
 5,052,237 A 10/1991 Reimann
 5,076,390 A 12/1991 Haskins
 5,087,103 A 2/1992 Pompier
 5,088,761 A 2/1992 Takehara et al.
 5,098,041 A 3/1992 Uetrecht
 5,111,899 A 5/1992 Reimann
 5,124,938 A 6/1992 Algrain
 5,125,468 A 6/1992 Coker
 5,136,219 A 8/1992 Takahashi
 5,158,493 A 10/1992 Morgrey
 5,161,820 A 11/1992 Vollmer
 5,165,711 A 11/1992 Tsai
 5,168,947 A 12/1992 Rodenborn
 5,171,173 A 12/1992 Henderson
 5,186,270 A 2/1993 West
 5,208,521 A 5/1993 Aoyama
 5,217,246 A 6/1993 Williams
 5,221,883 A 6/1993 Takenaka
 5,229,068 A 7/1993 Johansson et al.
 5,241,875 A 9/1993 Kochanneck
 5,248,007 A 9/1993 Watkins

(56)

References Cited

U.S. PATENT DOCUMENTS

5,261,503 A	11/1993	Yasui	6,092,249 A	7/2000	Kamen et al.
5,274,576 A	12/1993	Williams	D428,936 S *	8/2000	Serfaty D21/329
5,276,588 A	1/1994	Repplinger	6,105,704 A	8/2000	Hamada
5,276,624 A	1/1994	Ito	6,123,398 A	9/2000	Arai
5,297,646 A	3/1994	Yamamura	6,125,953 A	10/2000	Arai
5,307,888 A	5/1994	Urvoy	6,125,957 A	10/2000	Kauffmann
5,307,892 A	5/1994	Philips	6,131,057 A	10/2000	Tamaki
5,314,034 A	5/1994	Chittal	6,141,613 A	10/2000	Fan
5,350,033 A	9/1994	Kraft	6,148,939 A	11/2000	Brookhart
5,366,036 A	11/1994	Perry	6,154,692 A	11/2000	Cielaszyk
5,369,580 A	11/1994	Monji	D434,762 S *	12/2000	Ikenaga D14/218
5,376,868 A	12/1994	Toyoda	6,169,946 B1	1/2001	Griessbach
D355,148 S	2/1995	Orsolini	6,189,643 B1	2/2001	Takahashi
5,388,658 A	2/1995	Ando et al.	6,192,305 B1	2/2001	Schiffmann
5,397,890 A	3/1995	Schueler	6,208,734 B1	3/2001	Ortscheid et al.
5,408,411 A	4/1995	Nakamura	6,208,929 B1	3/2001	Matsuno et al.
5,408,811 A	4/1995	Satake	6,212,276 B1	4/2001	Inoue
5,417,298 A	5/1995	Shibahata	6,223,104 B1	4/2001	Kamen
5,419,624 A	5/1995	Adler	6,223,114 B1	4/2001	Boros
5,450,919 A	9/1995	Shitani	6,225,977 B1	5/2001	Li
5,465,806 A	11/1995	Higasa	D444,184 S	6/2001	Kettler
5,482,125 A	1/1996	Pagett	6,247,548 B1	6/2001	Hayashi
D373,121 S	8/1996	Deiuliis et al.	6,260,646 B1	7/2001	Fernandez et al.
5,551,756 A	9/1996	Gurasich et al.	6,263,261 B1	7/2001	Brown
5,576,959 A	11/1996	Hrovat	6,273,212 B1	8/2001	Husted et al.
D376,585 S	12/1996	Wathen et al.	6,276,471 B1	8/2001	Kratzenberg et al.
5,615,116 A	3/1997	Gudat	6,288,505 B1	9/2001	Heinzmann
D381,325 S *	7/1997	McMahan D14/388	6,292,722 B1	9/2001	Holmes et al.
5,646,845 A	7/1997	Gudat	6,302,230 B1	10/2001	Kamen
5,649,605 A	7/1997	Slashed	6,311,794 B1	11/2001	Morrell et al.
5,657,828 A	8/1997	Nagamachi	6,320,336 B1	11/2001	Eguchi
5,695,021 A	12/1997	Schaffner	6,324,446 B1	11/2001	Brown et al.
5,701,965 A	12/1997	Kamen	6,325,736 B1	12/2001	Hamada
5,701,968 A	12/1997	Wright-Ott	6,328,125 B1	12/2001	Van Den Brink et al.
5,705,746 A	1/1998	Trost	6,332,103 B1	12/2001	Stenson, Jr.
5,732,379 A	3/1998	Eckert	6,332,104 B1	12/2001	Brown
5,743,347 A	4/1998	Gingerich	6,343,664 B2	2/2002	Morrell et al.
5,746,282 A	5/1998	Fujiwara	6,356,188 B1	3/2002	Meyers
5,769,441 A	6/1998	Namngani	6,357,544 B1	3/2002	Kamen
5,774,819 A	6/1998	Yamamoto et al.	6,360,996 B1	3/2002	Bockman et al.
5,775,452 A	7/1998	Patmont	6,367,817 B1	4/2002	Kamen
5,791,425 A	8/1998	Kamen	6,371,228 B1	4/2002	Husted et al.
5,794,730 A	8/1998	Kamen	6,377,906 B1	4/2002	Rowe
5,799,745 A	9/1998	Fukatani	6,386,576 B1	5/2002	Kamen et al.
5,799,914 A	9/1998	Chivallier et al.	6,388,580 B1	5/2002	Graham
5,826,209 A	10/1998	Matsuno	6,397,046 B1	5/2002	Kfoury
D402,645 S	12/1998	Garguilo	6,405,816 B1	6/2002	Kamen et al.
5,848,660 A	12/1998	McGreen	6,408,240 B1	6/2002	Morrell et al.
5,850,136 A	12/1998	Kaneko	6,415,215 B1	7/2002	Nishizaki
5,869,943 A	2/1999	Nakashima et al.	6,415,879 B2	7/2002	Kamen et al.
5,869,946 A	2/1999	Carobolante	6,416,272 B1	7/2002	Suehiro
5,893,896 A	4/1999	Imamura et al.	6,435,535 B1	8/2002	Field
5,927,414 A	7/1999	Kan et al.	6,435,538 B2	8/2002	Ellis
5,928,309 A	7/1999	Korver	6,443,250 B1	9/2002	Kamen et al.
5,931,421 A	8/1999	Surauer et al.	6,443,251 B1	9/2002	Morrell et al.
5,939,864 A	8/1999	Lenhart et al.	6,463,369 B2	10/2002	Sadano
5,965,991 A	10/1999	Koike	D466,122 S	11/2002	Moody
5,971,091 A	10/1999	Kamen	6,484,829 B1	11/2002	Cox
5,973,463 A	10/1999	Okuda	D466,516 S	12/2002	Peiker
5,975,225 A	11/1999	Kamen	6,502,011 B2	12/2002	Haag
5,986,221 A	11/1999	Stanley	6,508,319 B1	1/2003	Langenfeld et al.
6,002,975 A	12/1999	Schiffmann	6,538,411 B1	3/2003	Field
6,003,624 A	12/1999	Jorgensen	6,543,564 B1	4/2003	Kamen
6,024,182 A	2/2000	Hamada et al.	6,543,848 B1	4/2003	Suga et al.
6,036,619 A	3/2000	Tashiro	6,543,858 B1	4/2003	Melton
6,039,142 A	3/2000	Eckstein	6,547,026 B2	4/2003	Kamen et al.
6,050,357 A	4/2000	Staelin	6,553,271 B1	4/2003	Morrell
6,052,647 A	4/2000	Parkinson	6,556,909 B2	4/2003	Matsumoto
6,053,579 A	4/2000	Nelson et al.	6,561,294 B1	5/2003	Kamen
6,059,062 A	5/2000	Staelin	6,562,511 B2	5/2003	Daroux
6,062,600 A	5/2000	Kamen et al.	6,571,176 B1	5/2003	Shinmura
6,062,651 A	5/2000	Schaad	6,571,892 B2	6/2003	Kamen
6,065,558 A	5/2000	Wielenga	6,575,539 B2	6/2003	Reich
6,076,033 A	6/2000	Hamada	6,581,714 B1	6/2003	Kamen
6,089,680 A	7/2000	Yoshioka et al.	6,582,181 B2	6/2003	Suehiro et al.
			6,586,901 B1	7/2003	Singer et al.
			6,593,849 B2	7/2003	Chubb
			6,598,941 B2	7/2003	Field et al.
			6,614,343 B1	9/2003	Fennel

(56)

References Cited

U.S. PATENT DOCUMENTS

6,615,938 B2	9/2003	Morrell et al.	7,316,441 B2	1/2008	Iwatani et al.
6,634,451 B2	10/2003	Sakakiyama	D564,033 S *	3/2008	Itskov D21/329
6,643,451 B1	11/2003	Tokura et al.	7,363,993 B2	4/2008	Ishii
6,647,248 B1	11/2003	Ortscheid et al.	7,370,713 B1	5/2008	Kamen
6,651,763 B1	11/2003	Kamen et al.	7,399,035 B2	7/2008	Kusanagi et al.
6,654,674 B2	11/2003	Lu	7,481,291 B2	1/2009	Nishikawa
6,654,675 B2	11/2003	Pedersen et al.	D585,906 S	2/2009	Berg
6,659,211 B2	12/2003	Esposito	D587,660 S *	3/2009	Lin D13/169
6,659,570 B2	12/2003	Nakamura	7,546,889 B2	6/2009	Kamen et al.
D485,279 S	1/2004	Decombe	D598,927 S	8/2009	Hirsch
6,694,225 B2	2/2004	Aga	7,589,643 B2	9/2009	Dagci
6,704,622 B2	3/2004	Tinskey	7,592,900 B2	9/2009	Kamen et al.
6,713,693 B1	3/2004	Sadowski	D601,922 S	10/2009	Imai et al.
D489,027 S	4/2004	Waters	7,640,086 B2	12/2009	Nakashima et al.
D489,029 S	4/2004	Waters	7,688,191 B2	3/2010	Lu
D489,300 S	5/2004	Chang	7,690,447 B2	4/2010	Kamen et al.
6,752,231 B2	6/2004	Hume	7,690,452 B2	4/2010	Kamen et al.
D493,127 S	7/2004	Waters	7,703,568 B2	4/2010	Ishii
D493,128 S	7/2004	Waters	D614,998 S	5/2010	Fujita
D493,801 S	8/2004	Byun	7,740,099 B2	6/2010	Field et al.
D494,099 S	8/2004	Maurer	7,757,794 B2	7/2010	Heinzmann
6,779,621 B2	8/2004	Kamen et al.	7,789,174 B2	9/2010	Kamen
6,781,960 B1	8/2004	Charas	7,823,676 B2	11/2010	Yamada et al.
6,789,640 B1	9/2004	Arling	7,857,088 B2	12/2010	Field
6,793,258 B2	9/2004	Gray	D632,229 S	2/2011	Kruse
6,796,396 B2	9/2004	Kamen	7,896,440 B2	3/2011	Tsai
6,799,649 B2	10/2004	Kamen et al.	7,900,725 B2	3/2011	Heinzmann et al.
6,827,163 B2	12/2004	Amsbury et al.	7,917,097 B2	3/2011	Hawkins et al.
D503,402 S *	3/2005	Su D14/388	7,958,956 B2	6/2011	Kakinuma et al.
6,866,107 B2	3/2005	Heinzmann et al.	8,011,459 B2	9/2011	Serai
6,868,931 B2	3/2005	Morrell	8,014,923 B2	9/2011	Ishii
D503,928 S	4/2005	Obata	8,025,325 B1	9/2011	Carrier et al.
6,874,591 B2	4/2005	Morrell et al.	8,028,777 B2	10/2011	Kakinuma
6,889,784 B2	5/2005	Troll	8,050,820 B2	11/2011	Yanaka
6,907,949 B1	6/2005	Wang	8,050,837 B2	11/2011	Yamada
D507,206 S	7/2005	Wang	8,074,388 B2	12/2011	Trainer
6,920,947 B2	7/2005	Kamen et al.	8,091,672 B2	1/2012	Gutsch
6,938,923 B2	9/2005	Mulhern et al.	8,113,244 B2	2/2012	Kamen et al.
6,962,383 B2	11/2005	Takenoshita et al.	8,151,912 B2	4/2012	Koide et al.
6,965,206 B2	11/2005	Kamen et al.	8,155,828 B2	4/2012	Fuwa et al.
6,969,079 B2	11/2005	Kamen et al.	8,160,794 B2	4/2012	Fuwa
7,000,933 B2	2/2006	Arling et al.	8,162,089 B2	4/2012	Shaw
7,004,271 B1	2/2006	Kamen et al.	8,170,780 B2	5/2012	Field
7,006,901 B2	2/2006	Wang	8,170,781 B2	5/2012	Fuwa
D517,086 S	3/2006	Siebel	8,172,016 B2	5/2012	Goertzen et al.
7,017,686 B2	3/2006	Kamen et al.	8,186,462 B2	5/2012	Kamen
D521,017 S	5/2006	Jewitt	8,224,524 B2	7/2012	Nakashima
7,040,713 B2	5/2006	Rudolf	8,225,891 B2	7/2012	Takenaka
D524,315 S	7/2006	Reusing	8,248,222 B2	8/2012	Kamen
7,090,040 B2	8/2006	Kamen et al.	8,249,773 B2	8/2012	Kawada
D528,468 S	9/2006	Arling	8,255,105 B2	8/2012	Weissert
D529,005 S *	9/2006	Hong D14/126	8,265,774 B2	9/2012	Senba
7,102,328 B2	9/2006	Long et al.	8,285,474 B2	10/2012	Doi
7,130,702 B2	10/2006	Morrell	8,312,017 B2	11/2012	Martin et al.
7,174,976 B2	2/2007	Kamen et al.	8,346,441 B2	1/2013	Miki
7,178,611 B2	2/2007	Zupanick	8,371,410 B2	2/2013	Fuwa
7,178,614 B2	2/2007	Ishii	D678,217 S *	3/2013	Helm D13/162
7,182,166 B2	2/2007	Gray et al.	D678,320 S	3/2013	Kanalakis, Jr.
D539,810 S	4/2007	Cummins	8,417,404 B2	4/2013	Yen
7,198,223 B2	4/2007	Phelps, III et al.	8,418,705 B2	4/2013	Ota et al.
7,210,544 B2	5/2007	Kamen et al.	8,453,768 B2	6/2013	Kamen
7,219,912 B2	5/2007	Meyer	8,467,941 B2	6/2013	Field
D544,486 S	6/2007	Hussaini	D686,200 S *	7/2013	Huang D14/253
7,234,779 B2	6/2007	Bedford et al.	8,490,723 B2	7/2013	Heinzmann
D546,782 S *	7/2007	Poulet D13/168	8,504,248 B2	8/2013	Taira
D549,721 S	8/2007	Ito	8,564,444 B2	10/2013	Ota et al.
D551,592 S	9/2007	Chang et al.	8,584,782 B2	11/2013	Chen
D551,722 S	9/2007	Chang et al.	8,621,684 B2	1/2014	Okumatsu
7,273,116 B2	9/2007	Kamen et al.	8,636,451 B2	1/2014	Yamashita et al.
D552,609 S	10/2007	Kornblum	8,639,416 B2	1/2014	Jones
7,275,607 B2	10/2007	Kamen et al.	8,640,807 B2	2/2014	Takenaka
D556,149 S *	11/2007	Kaufhold D13/162	8,672,339 B2	3/2014	Raike, III
D557,220 S *	12/2007	Ewringmann D13/164	8,672,356 B2	3/2014	Inaguma
D557,221 S *	12/2007	Ewringmann D13/164	8,684,123 B2	4/2014	Chen
7,303,032 B2	12/2007	Kahlert et al.	8,690,265 B2	4/2014	Noblanc
			D704,621 S *	5/2014	Taylor D12/197
			D705,799 S	5/2014	Funabashi
			8,738,238 B2	5/2014	Rekow
			8,738,278 B2	5/2014	Chen

(56)

References Cited

U.S. PATENT DOCUMENTS

D706,807 S	6/2014	Harre		2002/0189870 A1	12/2002	Kamen	
D707,701 S	6/2014	D'Amore		2003/0014167 A1	1/2003	Pedersen	
8,753,208 B2	6/2014	Jaouen et al.		2003/0128840 A1	7/2003	Luginbill	
D708,203 S	7/2014	Johnson		2003/0226698 A1	12/2003	Kamen	
8,807,250 B2	8/2014	Chen		2004/0005958 A1	1/2004	Kamen	
8,830,048 B2	9/2014	Kamen et al.		2004/0007399 A1	1/2004	Heinzmann	
8,832,875 B2	9/2014	Odashima et al.		2004/0007644 A1	1/2004	Phelps, III et al.	
D716,325 S	10/2014	Brudnicki		2004/0055796 A1	3/2004	Kamen	
8,860,551 B2	10/2014	Carraher		2004/0069543 A1	4/2004	Kamen	
D716,818 S	11/2014	Alegiani		2004/0124655 A1	7/2004	Takenoshita et al.	
8,925,563 B2	1/2015	Ota et al.		2004/0135434 A1	7/2004	Honda	
8,958,976 B2	2/2015	Kajima		2004/0201271 A1	10/2004	Kakinuma	
D723,558 S *	3/2015	Downs	D12/133	2004/0256886 A1	12/2004	Wu	
8,978,791 B2	3/2015	Ha		2004/0262871 A1	12/2004	Schreuder	
9,016,410 B2	4/2015	Trowell et al.		2005/0029023 A1	2/2005	Takami	
D729,270 S	5/2015	Clare		2005/0121866 A1	6/2005	Kamen	
D729,833 S	5/2015	Clare		2005/0134014 A1	6/2005	Xie	
9,038,212 B2	5/2015	Yamaguchi et al.		2005/0211477 A1	9/2005	Gray	
D732,062 S	6/2015	Kwon		2005/0236208 A1	10/2005	Runkles	
9,045,190 B2	6/2015	Chen		2005/0236894 A1	10/2005	Lu	
D738,907 S	9/2015	Cabrera-Cordon		2006/0108956 A1	5/2006	Clark	
D738,913 S	9/2015	Cabrera-Cordon		2006/0163437 A1	7/2006	Lin	
9,126,497 B2	9/2015	Heinzmann		2006/0202439 A1	9/2006	Kahlert	
9,156,516 B2	10/2015	Kahlert		2006/0231313 A1	10/2006	Ishii	
D742,300 S *	11/2015	Fontaeus	D12/415	2006/0279554 A1	12/2006	Shin	
D742,407 S	11/2015	Park		2007/0001830 A1	1/2007	Dagci	
D742,795 S	11/2015	Siao		2007/0100511 A1	5/2007	Koerlin	
D750,179 S *	2/2016	Foulkes	D14/400	2007/0213900 A1	9/2007	Raab	
D752,572 S *	3/2016	Kohler	D14/302	2007/0221423 A1	9/2007	Chang	
D755,785 S *	5/2016	Sirotych	D14/341	2007/0296170 A1	12/2007	Field	
D757,732 S	5/2016	Galanti		2008/0029985 A1	2/2008	Chen	
D758,284 S *	6/2016	Ringer	D12/415	2008/0147281 A1	6/2008	Ishii	
D762,179 S *	7/2016	Wong	D13/168	2008/0149798 A1	6/2008	Tinoco	
D763,359 S *	8/2016	Kwong	D14/401	2008/0174415 A1	7/2008	Tanida	
D764,520 S	8/2016	Lee		2008/0197599 A1	8/2008	Comstock	
D765,718 S	9/2016	Vinna		2008/0238005 A1	10/2008	James	
D769,314 S	10/2016	Piroddi		2008/0302938 A1	12/2008	Goodwin	
D770,514 S	11/2016	Bae		2009/0009984 A1	1/2009	Mangiardi	
D772,255 S	11/2016	Taylor		2009/0032323 A1	2/2009	Kakinuma	
D772,924 S	11/2016	Begin		2009/0078485 A1	3/2009	Gutsch	
D775,148 S	12/2016	Anzures		2009/0105908 A1	4/2009	Casey	
D775,345 S *	12/2016	Aguirre	D24/164	2009/0115149 A1	5/2009	Wallis	
D778,312 S	2/2017	Goodwin		2009/0224524 A1	9/2009	Rathsack	
D784,296 S *	4/2017	Katsuno	D14/218	2010/0025139 A1	2/2010	Kosaka	
D786,278 S	5/2017	Motamedi		2010/0107076 A1	4/2010	Grohman	
D786,770 S *	5/2017	Smallhorn	D12/345	2010/0114468 A1	5/2010	Field	
D787,420 S *	5/2017	Smallhorn	D12/345	2010/0121538 A1	5/2010	Ishii	
9,662,438 B2	5/2017	Kamen et al.		2010/0126787 A1	5/2010	Kawada	
D792,444 S	7/2017	Cho		2010/0222994 A1	9/2010	Field	
D797,772 S	9/2017	Mizono		2010/0230919 A1	9/2010	Kawada	
D798,318 S	9/2017	Ferguson		2010/0235028 A1	9/2010	Ishii	
9,750,896 B2	9/2017	Kamen et al.		2010/0237645 A1	9/2010	Trainer	
D801,996 S	11/2017	Yang		2010/0250040 A1	9/2010	Yamano	
D802,002 S	11/2017	Howard		2011/0035101 A1	2/2011	Kawada et al.	
D804,393 S *	12/2017	Yoo	D12/415	2011/0209929 A1	9/2011	Heinzmann	
D805,972 S *	12/2017	Lee	D12/174	2011/0215540 A1	9/2011	Hunziker et al.	
D805,973 S *	12/2017	Mullaney	D12/177	2011/0220427 A1	9/2011	Chen	
D807,235 S *	1/2018	Collins	D12/133	2011/0221160 A1	9/2011	Shaw	
D807,236 S *	1/2018	Collins	D12/133	2011/0238247 A1	9/2011	Yen	
D807,277 S *	1/2018	Lee	D12/415	2011/0285195 A1	11/2011	Ratgen	
D812,533 S *	3/2018	Lee	D12/174	2012/0197470 A1	8/2012	Inui	
D814,370 S *	4/2018	Kim	D12/174	2012/0205176 A1	8/2012	Ha	
D825,437 S *	8/2018	Hilton	D12/415	2012/0219395 A1	8/2012	Inaguma et al.	
D825,493 S *	8/2018	Chen	D13/164	2012/0239284 A1	9/2012	Field	
D825,497 S *	8/2018	Mizushi	D13/168	2012/0290162 A1	11/2012	Stevens	
D829,612 S *	10/2018	Collins	D12/133	2013/0032422 A1	2/2013	Chen	
D844,622 S *	4/2019	Collins	D14/447	2013/0032423 A1	2/2013	Chen	
D846,452 S *	4/2019	Collins	D12/133	2013/0105239 A1	5/2013	Fung	
D846,504 S *	4/2019	Yang	D13/162	2013/0228385 A1	9/2013	Chen	
2002/0007239 A1	1/2002	Matsumoto		2013/0253769 A1	9/2013	Kamo	
2002/0056582 A1	5/2002	Chubb		2014/0018994 A1	1/2014	Panzarella	
2002/0063006 A1	5/2002	Kamen		2014/0058600 A1	2/2014	Hoffmann	
2002/0082749 A1	6/2002	Meyers		2014/0083225 A1 *	3/2014	Downs	B60K 37/06 74/471 XY
2002/0121394 A1	9/2002	Kamen		2014/0277888 A1	9/2014	Dastoor	
2002/0121572 A1	9/2002	Jacobson		2015/0060162 A1	3/2015	Goffer	
				2015/0112264 A1	4/2015	Kamen et al.	
				2015/0123453 A1	5/2015	Benoit, Jr.	
				2015/0198440 A1	7/2015	Pearlman	

(56)

References Cited

U.S. PATENT DOCUMENTS

2015/0231891	A1	8/2015	Yashiro et al.
2015/0245962	A1	9/2015	Furuta
2015/0246703	A1	9/2015	Oishi et al.
2015/0289653	A1	10/2015	Hector et al.
2016/0014252	A1	1/2016	Biderman et al.
2016/0035161	A1	2/2016	Friedli et al.
2016/0264019	A1	9/2016	Drako
2017/0176188	A1	6/2017	Georgy
2017/0240169	A1	8/2017	Coulter et al.
2017/0259811	A1	9/2017	Coulter et al.
2017/0300058	A1	10/2017	Peret et al.
2018/0056985	A1	3/2018	Coulter et al.
2018/0102227	A1	4/2018	Poon
2018/0164829	A1*	6/2018	Oshima A61G 5/04
2018/0203522	A1*	7/2018	Stucki B60L 50/50

FOREIGN PATENT DOCUMENTS

CA	2897221	3/2006
CN	101056680	10/2007
CN	104071275	10/2014
DE	2048593	5/1971
DE	3103961	9/1982
DE	3128112	2/1983
DE	3242880	6/1983
DE	3411489	10/1984
DE	4110905	10/1991
DE	4404594	8/1995
DE	19625498	11/1997
DE	29808091	8/1998
DE	29808096	8/1998
DE	10209093	9/2003
EP	0109927	5/1984
EP	0193473	9/1986
EP	0537698	4/1993
EP	0551986	7/1993
EP	0663313	7/1995
EP	0746089	12/1996
EP	0958978	11/1999
EP	1063530	12/2000
EP	1759973	3/2007
EP	1805071	7/2007
FR	980237	5/1951
FR	2502090	9/1982
GB	152664	1/1922
GB	1213930	11/1970
GB	2139576	11/1984
GB	2388579	11/2003
JP	52-44933	4/1977
JP	57-87766	1/1982
JP	57-110569	7/1982
JP	59-73372	4/1984
JP	60-255580	12/1985
JP	62-12810	1/1987
JP	63-305082	12/1988
JP	H01-316810	12/1989
JP	2-190277	7/1990
JP	4-201793	7/1992
JP	5-213240	8/1993
JP	6-171562	12/1994
JP	61-05415	12/1994
JP	7255780	10/1995
JP	9-248320	9/1997
JP	10-023613	1/1998
JP	2000-070308	7/2000
JP	2000-288032	10/2000
JP	2005-022631	1/2005
JP	4572594	1/2006
JP	2007-069688	3/2007
JP	D1314974	11/2007
JP	D1323922	3/2008
JP	4687784	7/2010
JP	2010-240011	10/2010
JP	2010-274759	12/2010
JP	2011-246124	12/2011

JP	5243795	7/2013
JP	2014-019212	2/2014
JP	2014-174275	9/2014
JP	2014-195403	10/2014
JP	2014-218247	11/2014
JP	2015-070897	4/2015
JP	2015-171895	10/2015
JP	2016-084135	5/2016
JP	2018-062344	4/2018
TW	D124942	6/2006
TW	D124943	6/2006
WO	WO 1986/05752	10/1986
WO	WO 1989/06117	7/1989
WO	WO 1996/23478	8/1996
WO	WO 1998/46474	10/1998
WO	WO 1999/11488	3/1999
WO	WO 2000/023315	4/2000
WO	WO 2000/054719	9/2000
WO	WO/2000/054721	9/2000
WO	WO 2000/075001	12/2000
WO	WO 2001/002920	1/2001
WO	WO/2002/030730	4/2002
WO	WO 2002/072383	9/2002
WO	WO/2002/072383	9/2002
WO	WO/2003/103559	12/2003
WO	WO/2003/106250	12/2003
WO	WO 2004/007264	1/2004
WO	WO/2004/078603	9/2004
WO	WO 2006/031917	3/2006
WO	WO 2006/042302	4/2006
WO	WO 2009/052471	4/2009
WO	WO 2010/084421	7/2010
WO	WO/2012/090248	7/2012
WO	WO/2013/096789	6/2013
WO	WO 2015/167411	11/2015
WO	WO 2017/147347	8/2017
WO	WO 2017/180868	10/2017
WO	WO 2017/201513	11/2017

OTHER PUBLICATIONS

Introducing electric wheelchair without stairs Scewo. blog.naver.com. [online] 2 pgs. Posted Mar. 19, 2017. [Retrieved on Aug. 15, 2018] <http://blog.naver.com/PostView.nhn?blogId=hwh7588&logNo=220987227590&categoryNo=0&parentCategoryNo=0&viewDate=20170319¤tPage=1&postListTopCurrentPage=1&from=postView>.*

Controllers. (Design—© Questel) orbit.com.[online PDF] 9 pgs. Print Dates range Oct. 16, 2013 to Mar. 25, 2015. [Retrieved on Aug. 15, 2018] <https://sobjprd.questel.fr/export/QPTUJ214/pdf2/ded442a0-b76c-4173-9dae-7cbb93247074-235637.pdf>.*

Adhikari, B., A Single Subject Participatory Action Design Method for Powered Wheelchairs Providing Automated Back-in Parking Assistance to Cognitively Impaired Older Adults: A pilot study, Department of Computer Science, The University of British Columbia, Vancouver, Canada, Jan. 5, 2015, slide deck.

Adhikari, B., A Single Subject Participatory Action Design Method for Powered Wheelchairs Providing Automated Back-in Parking Assistance to Cognitively Impaired Older Adults: A pilot study, Master's Thesis, Department of Computer Science, The University of British Columbia, Vancouver, Canada, Dec. 2014.

Brown, Jr. et al., "A Single-Wheel Gyroscopically Stabilized Robot," IEEE Robotics & Automation Magazine, Sep. 1997.

Cooper, Rory A., Intelligent Control of Power Wheelchairs, IEEE Engineering in Medicine and Biology Magazine, IEEE Service Center, Piscataway, NJ, US, vol. 14, No. 4, Jul. 1, 1995, pp. 423-431, XP11084628.

Dejun Yin and Yoichi Hori, "A Novel Traction Control for Electric Vehicle without Chassis Velocity, Motion Control", Federico Casolo (Ed.), InTech, DOI: 10.5772/6962. Available from: <https://mts.intechopen.com/books/motion-control/a-novel-traction-control-for-electric-vehicle-without-chassis-velocity>, 2010.

Elnagar, A., "Prediction of Moving Objects in Dynamic Environments Using Kalman Filters," Proceedings of 2001 IEEE International Symposium on Computational Intelligence in Robotics and Automation, Jul. 29-Aug. 1, 2001.

(56)

References Cited

OTHER PUBLICATIONS

- Fresk, et al., Full Quaternion Based Attitude Control for a Quadrotor, 2013 European Control Conference (EDD), Jul. 17-19, 2013, Zurich, Switzerland, pp. 3864-3869.
- Grasser, F. et al., "JOE: A Mobile, Inverted Pendulum," IEEE Transactions on Industrial Electronics, vol. 49, No. 1, Feb. 2002.
- Ha, et al. "Trajectory Tracking Control for Navigation of Self-Contained Mobile Inverse Pendulum" Intelligent Robots and Systems '94. 'Advanced Robotic Systems and the Real World', IROS '94. Proceedings of the IEEE/RSJ/GI International Conference on, vol. 3, No., pp. 1875-1882, Sep. 12-16, 1994.
- Ha, et al., "Trajectory Tracking Control for Navigation of the Inverse Pendulum Type Self-Contained Mobile Robot" 17 Robotics and Autonomous Systems 60-85 (1996).
- Helgesson, L., "Pitch and roll estimating kalman filter for stabilizing quadcopters", <http://lhelge.se/2012/04/pitch-and-roll-estimating-kalman-filter-for-stabilizing-quadcopters/>, Oct. 15, 2012.
- How et al., "Clinical Evaluation of the Intelligent Wheelchair System", Proceedings of Festival of international Conference on Caregiving, Disability, Aging and Technology, Toronto, Canada, 2011.
- Introducing electric wheelchair without stairs Scewo.blog.naver.com. [online] 2 pgs. Posted Mar. 19, 2017. [Retrieved on Aug. 15, 2018] <http://blog.naver.com/PostView.nhn?blogId=hwh7588&logNo=220987227590&categoryNo=0&parentCategoryNo=0&viewDate=¤tPage=1&postListTopCurrentPage=1&from=postView>.
- I-Real, Personal Mobility Device, <https://www.youtube.com/watch?v=WAGpx1UpdWw>, Published on Jan. 15, 2013, appeared first in Apr. 2012, D1 Grand Prix event, Odaiba, JP.
- Ishida and Miyamoto, "Collision-Detecting Device for Omnidirectional Electric Wheelchair", Research Article, ISRN Robotics, vol. 2013, Article ID 672826, Nov. 1, 2012.
- I-swing, Single Person Vehicle, https://www.youtube.com/watch?feature=player_embedded&v=1QSybf7sLtg, Published on Sep. 14, 2006, Featured on Hacked Gadgets, <http://hackedgadgets.com>.
- I-Unit, Wheelchair, <https://www.youtube.com/watch?v=RbrrIrh3GBE>, Published on Jun. 6, 2006, Filmed at Megaweb Center at Tokyo.
- Johnson, R.C., "Unicycles and bifurcations", American J. of Physics, vol. 66, No. 7, 589-92 (Oct. 22, 2002).
- Kanoh, "Applied Control of Inverted Pendulum", Computrol, vol. 2, (1983), pp. 69-75.
- Kawaji, S., Stabilization of Unicycle Using Spinning Motion, Denki Gakkai Ronbunshi, D, vol. 107, Issue 1, Japan (1987), pp. 21-28.
- Koyanagi et al., A Wheeled Inverse Pendulum Type Self-Contained Mobile Robot, The Society of Instrument and Control Engineers, Special issue of the 31st SICE Annual Conference, Japan 1992, pp. 51-56.
- Koyanagi et al., A Wheeled Inverse Pendulum Type Self-Contained Mobile Robot and its Two Dimensional Trajectory Control, Proceeding of the Second International Symposium on Measurement and Control in Robotics, Japan 1992, pp. 891-898.
- Koyanagi et al., A Wheeled Inverse Pendulum Type Self-Contained Mobile Robot and its Posture Control and Vehicle Control, The Society of Instrument and Control Engineers, Special issue of the 31st SICE Annual Conference, Japan, 1992, pp. 13-16.
- Lam, H. K. et al., "Fuzzy Model Reference Control of Wheeled Mobile Robots," The 27th Annual Conference of the IEEE Industrial Electronics Society (2001).
- Liu, H.S. et al., "Accelerometer for Mobile Robot Positioning," IEEE Transactions on Industry Applications, vol. No. 3, Oct. 1999.
- Momoi & Yamafuji, Motion Control of the Parallel Bicycle-Type Mobile Robot Composed of a Triple Inverted Pendulum, Paper Read at Meeting of Japan Society of Mechanical Engineering (Series C), vol. 57, No. 541, (Sep. 1991), pp. 154-159.
- Montella, C., et al., To the Bookstore! Autonomous Wheelchair Navigation in an Urban Environment, Lehigh University, published in FSR, 2012, Part of the Springer Tracts in Advanced Robotics book series (STAR, vol. 92), first online Dec. 31, 2013.
- Oishi et al., Building a Smart Wheelchair on a Flexible Software Platform, RESNA International Conference on Technology and Aging, 2011.
- Osaka et al., Stabilization of unicycle, Systems and Control, vol. 25, No. 3, Japan Mar. 1981, pp. 159-166.
- PCT/US2017/019214, Written Opinion of the International Search Authority, dated Aug. 31, 2017.
- PCT/US2017/027410, Written Opinion of the International Search Authority, dated Dec. 4, 2017.
- PCT/US2017/033705, Written Opinion of the International Search Authority, dated Nov. 23, 2017.
- Roy et al., Five-Wheel Unicycle System, Medical & Biological Engineering & Computing, vol. 23, No. 6, United Kingdom Nov. 1985, pp. 593-596.
- Sabatini, A., "Quaternion-based Extended Kalman Filter for Determining Orientation by Inertial and Magnetic Sensing", IEEE Transactions on Biomedical Engineering, vol. 53:7, Jul. 2006, pp. 1346-1356.
- Schoonwinkel, A. Design and Test of a Computer-Stabilized Unicycle, Stanford University (1988), UMI Dissertation Services, Dissertation Abstracts International, vol. 49/03-B, Stanford University 1987, pp. 890-1294.
- Sheng et al., "Postural Stability of a Human Riding a Unicycle and Its Emulation by a Robot," IEEE Transactions on Robotics and Automation, vol. 13:5, Oct. 1997.
- Sheng, Zaiquan; Yamafuji, Kazuo: Realization of a Human Riding a Unicycle by a Robot. Proceedings of the 1995 IEEE International Conference on Robotics and Automation, vol. 2, 1995, pp. 1319-1326.
- Stew's Hovercraft Page, <http://www.stewcam.com/hover-craft.html>.
- Takahashi et al., "Back and Forward Moving Scheme of Front Wheel Raising for Inverse Pendulum Control Wheel Chair Robot", Proceedings of the 2001 IEEE International Conference of Robotics & Automation, Seoul, Korea, May 21-26, 2001, pp. 3189-3194.
- Takahashi et al., "Front Wheel Raising and Inverse Pendulum Control of Power Assist Wheel Chair Robot", IEEE, 1999, pp. 668-673.
- Tanaka et al., "A Mobile Robot for Service Use: Behaviour Simulation System and Intelligent Control," Proceedings of the 1997 IEEE/RSJ International Conference on Intelligent Robots and Systems, 1997.
- Technico's Home Page, Those Amazing Flying Machines, <http://www.swiftsite.com/technico>, May 24, 1999.
- Ulyanov et al., "Fuzzy Intelligent Emotion and Instinct Control of a Robotic Unicycle," Proceedings of the 1996 4th International Workshop on Advanced Motion Control, Mar. 18-21, 1996.
- Ulyanov et al., Soft computing for the intelligent robust control of a robotic unicycle with a new physical measure for mechanical controllability. Soft Computing vol. 2:2, Jun. 1998, pp. 73-88.
- Viswanathan et al., "Navigation Assistance for Intelligent Wheelchairs", 3rd International Conference on Technology and Aging/RESNA, Toronto, 2011.
- Vos et al., Dynamics and Nonlinear Adaptive Control of an Autonomous Unicycle—Theory and Experiment, American Institute of Aeronautics and Astronautics, A90-26772 10-39, Washington, D.C. 1990, Abstract only.
- Vos, D., Dynamics and Nonlinear Adaptive Control of an Autonomous Unicycle, Massachusetts Institute of Technology, Jun. 7, 1989.
- Vos, D., Nonlinear Control of an Autonomous Unicycle Robot: Practical Issues, Massachusetts Institute of Technology, Jun. 5, 1992.
- Wang et al., "Real-time Model-based Electrical Powered Wheelchair Control", Med Eng Phys. Dec. 2009: 31(10): 1244-1254.
- Watson Industries, Inc., "Vertical Reference Manual ADS-C132-1A", Apr. 20, 2015, pp. 3-4.
- Welch et al., "An Introduction to the Kalman Filter," SIGGRAPH 2001, Department of Computer Science University of North Carolina at Chapel Hill, <http://www.cs.unc.edu/~{welch,gb}>, 2001.
- WO 2000/073101, IPER of the International Search Authority, filing date Mar. 14, 2000.

(56)

References Cited

OTHER PUBLICATIONS

WO 2000/075001, IPER of the International Search Authority, filing date Jun. 1, 2000.

WO2002/030730, IPER of the International Search Authority, filing date Oct. 11, 2001.

WO 2017/147347 Written Opinion of the International Search Authority, Int. App. #PCT/US2017/019214, priority date Feb. 23, 2016.

WO 2017/201513, Invitation to pay additional fees and partial search report, Int. App. #PCT/US2017/033705, Intl. filing date May 20, 2017.

WO 2017/201513, Written Opinion of the International Searching Authority, Int. App. #PCT/US2017/033705, Intl. filing date May 20, 2017.

Yamafuji & Kawamura, "Study of Postural and Driving Control of Coaxial Bicycle", Paper Read at Meeting of Japan Society of Mechanical Engineering (Series C), vol. 54, No. 501, (May 1988), pp. 1114-1121, Abstract in English.

Yamafuji et al., Synchronous Steering Control of a Parallel Bicycle, Paper Read at Meeting of Japan Society of Mechanical Engineering (Series C), vol. 55, No. 513, (May 1989), pp. 1229-1234.

Yamafuji, A Proposal for Modular-Structured Mobile Robots for Work that Principally Involve a Vehicle with Two Parallel Wheels, Automation Technology, vol. 20, pp. 113-118 (1988).

Yun et al., "Implementation and Experimental Results of a Quaternion-Based Kalman Filter for Human Body Motion Tracking", Proceedings of the 2005 IEEE International Conference on Robotics and Automation, Barcelona, Spain, Apr. 2005, pp. 317-322.

Yun et al., "Design, Implementation and Experimental Results of a Quaternion-Based Kalman Filter for Human Body Motion Tracking", IEEE Transactions on Robotics, vol. 22, No. 6, Dec. 2006, pp. 1216-1227.

Zenkov, DV, AM Bloch, and JE Marsden [2001] The Lyapunov-Malkin Theorem and Stabilization of the Unicycle with Rider. Systems and Control Letters, vol. 45, No. 4, Apr. 5, 2002, pp. 293-302(10).

Zenkov, DV, AM Bloch, NE Leonard and JE Marsden, Matching and Stabilization of Low dimensional Nonholonomic Systems. Proc. CDC, 39, (2000), 1289-1295.

* cited by examiner

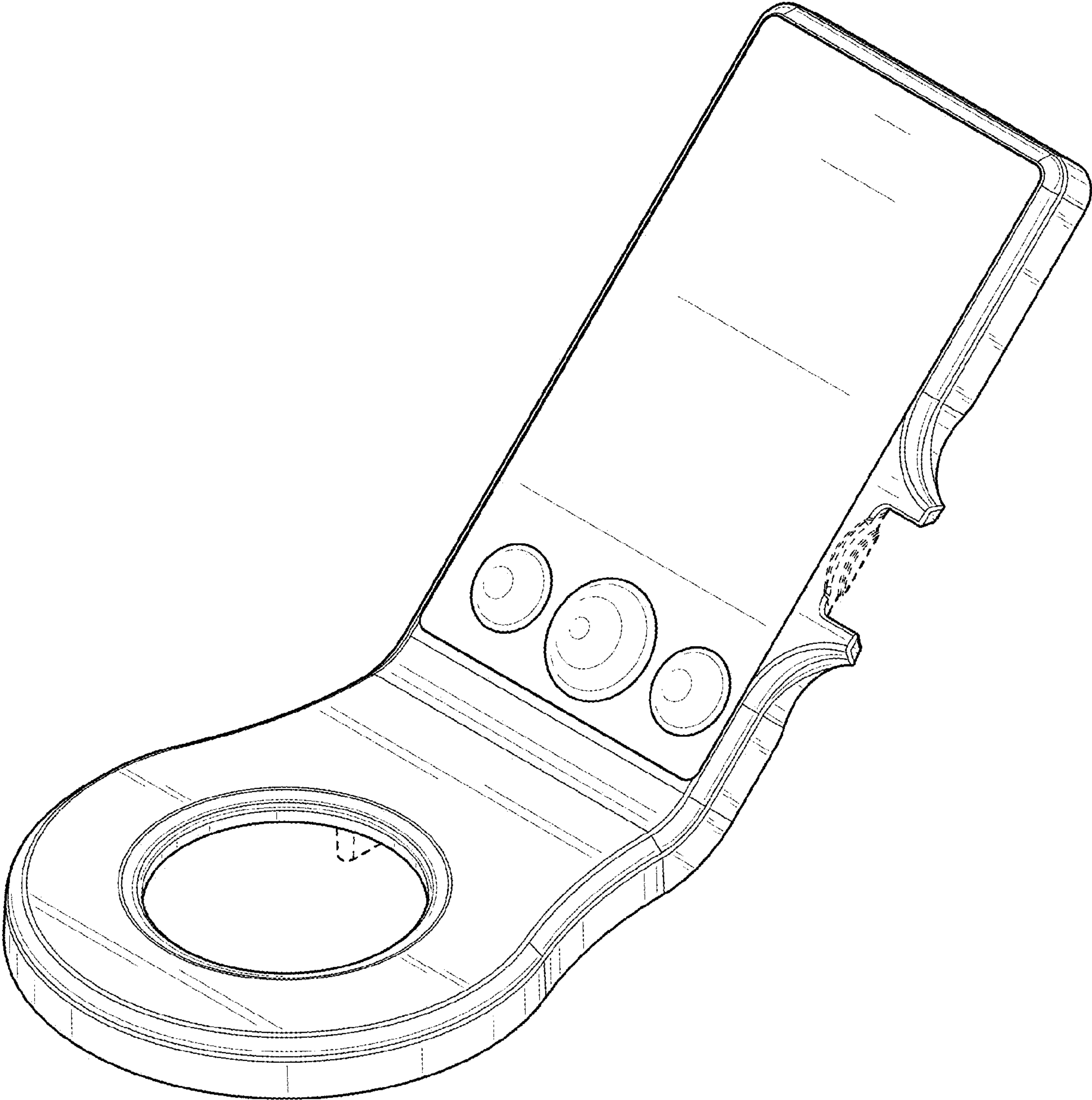

FIG. 1

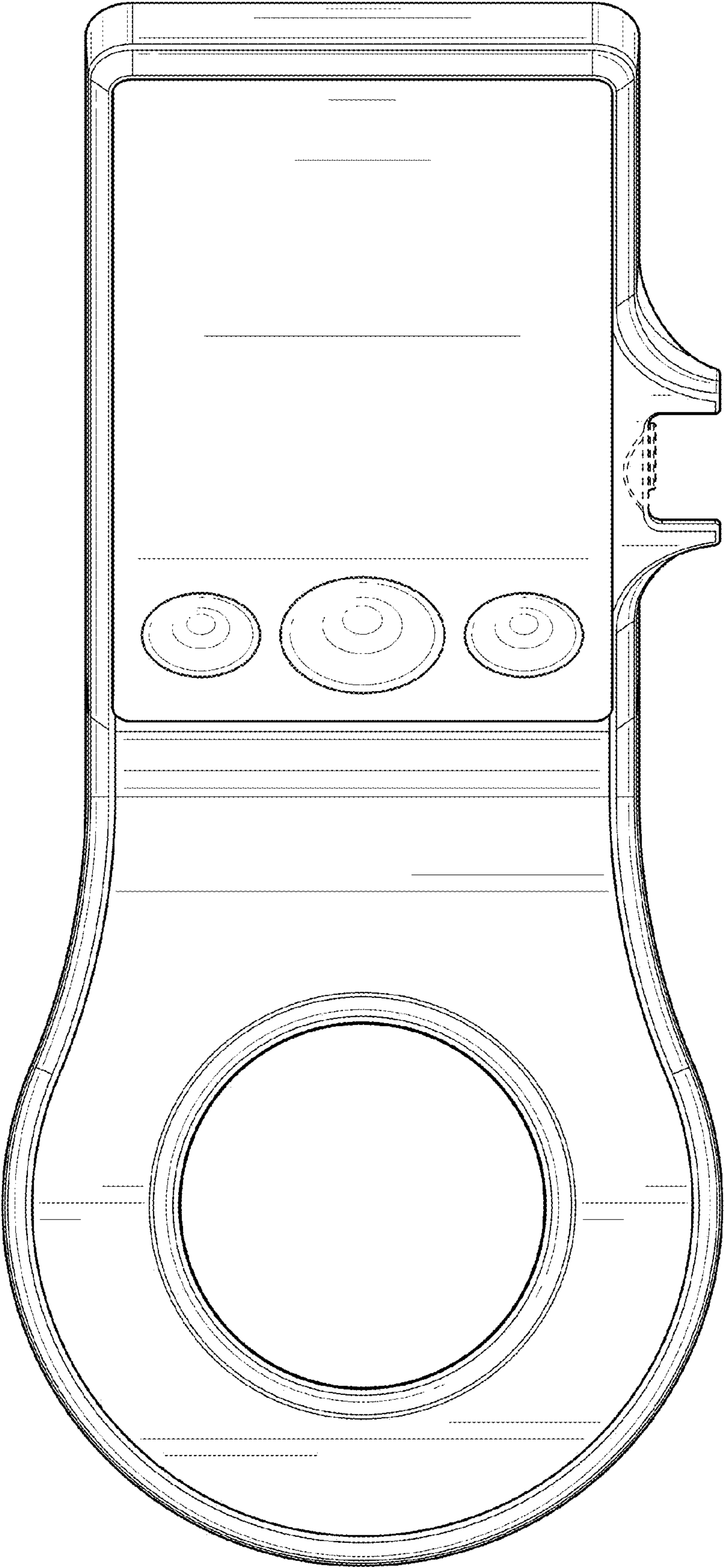

FIG. 2

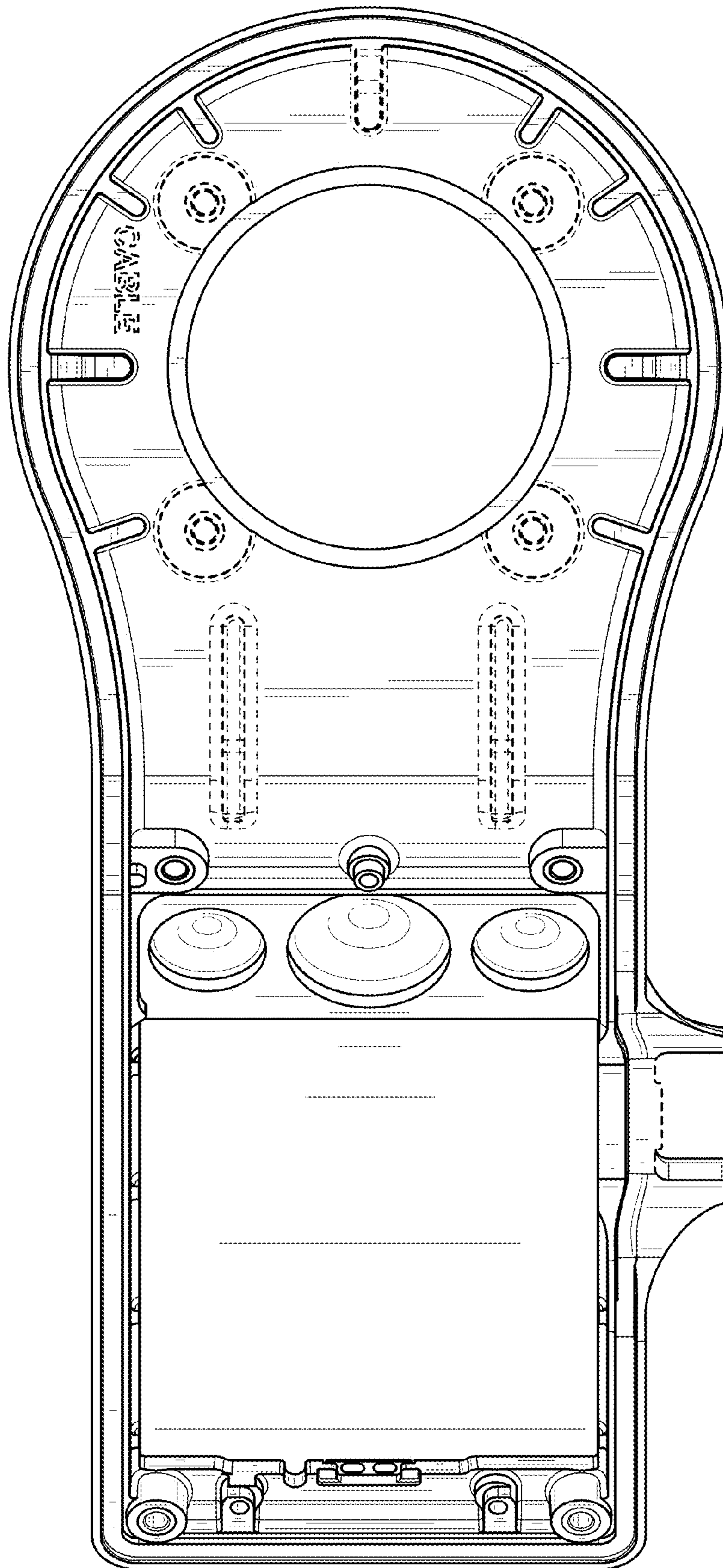

FIG. 3

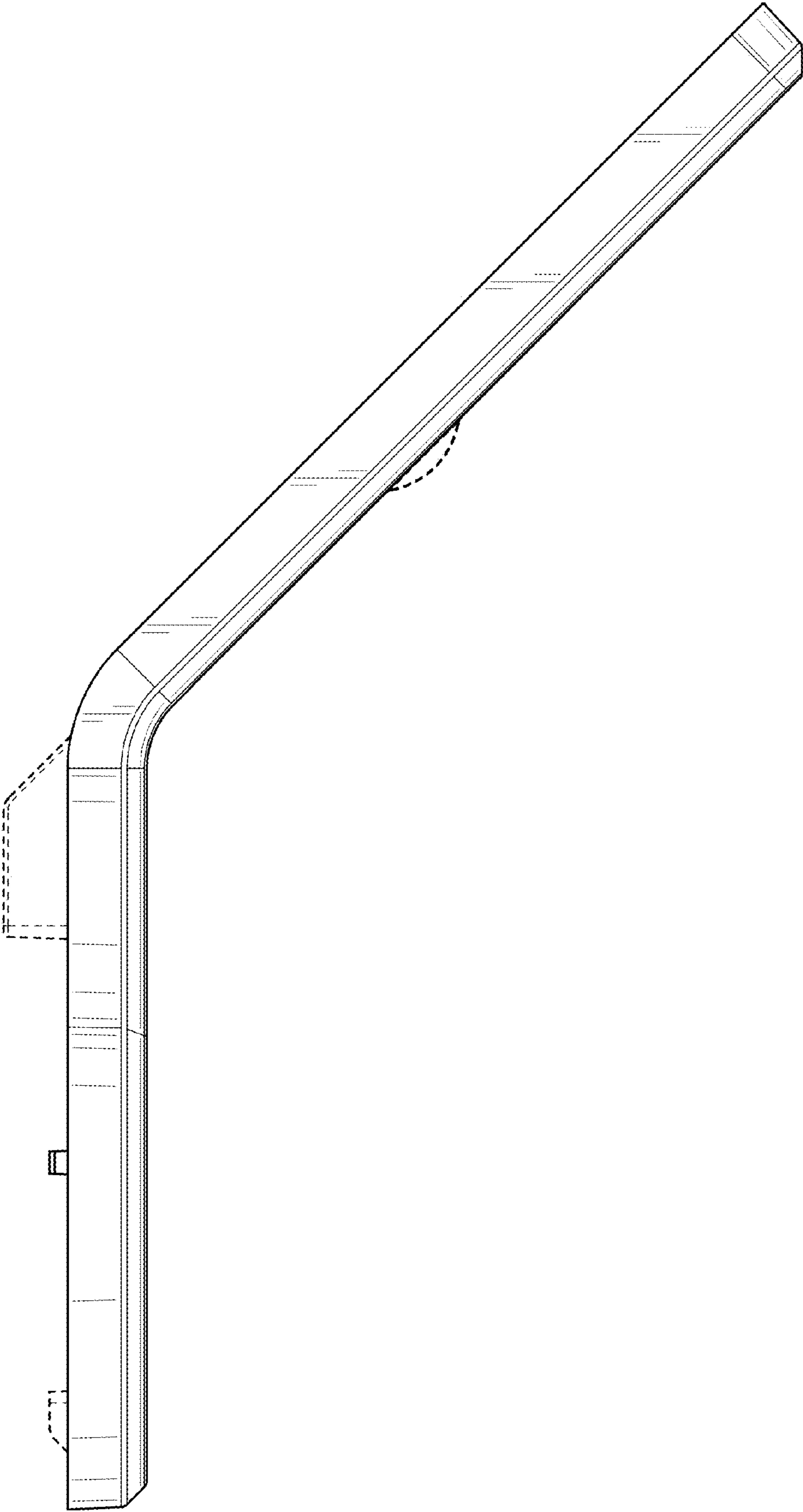

FIG. 4

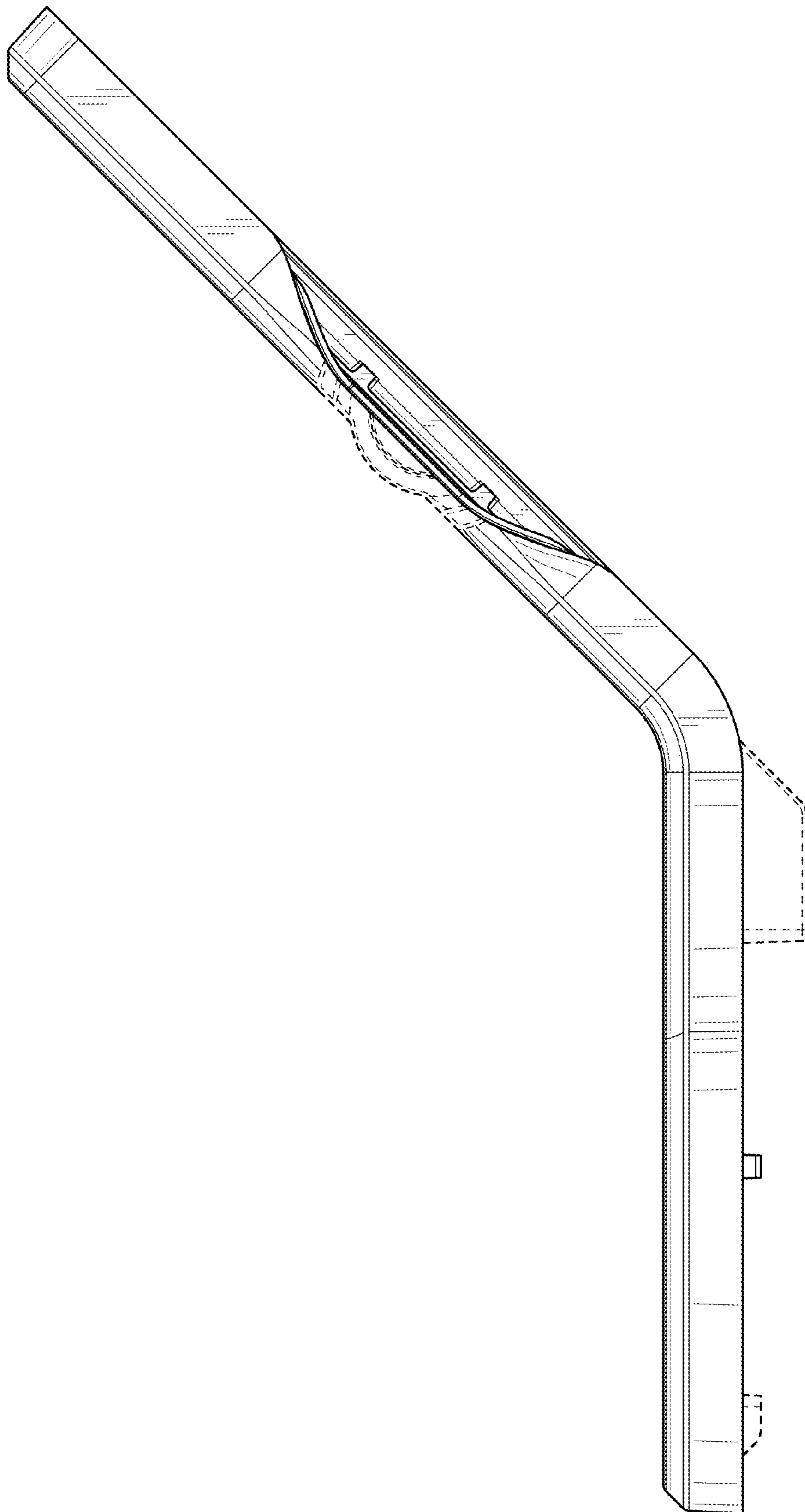

FIG. 5

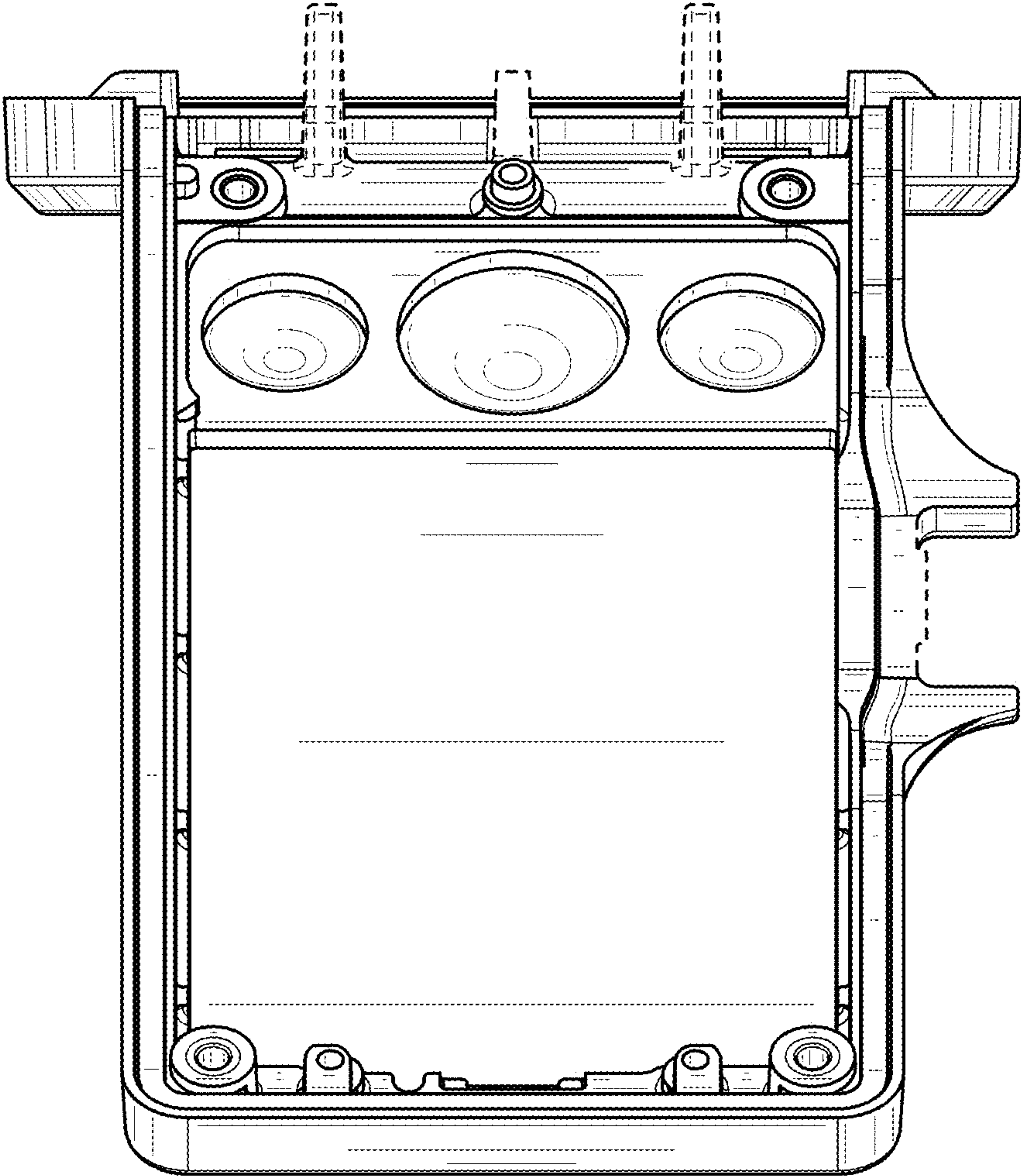

FIG. 6

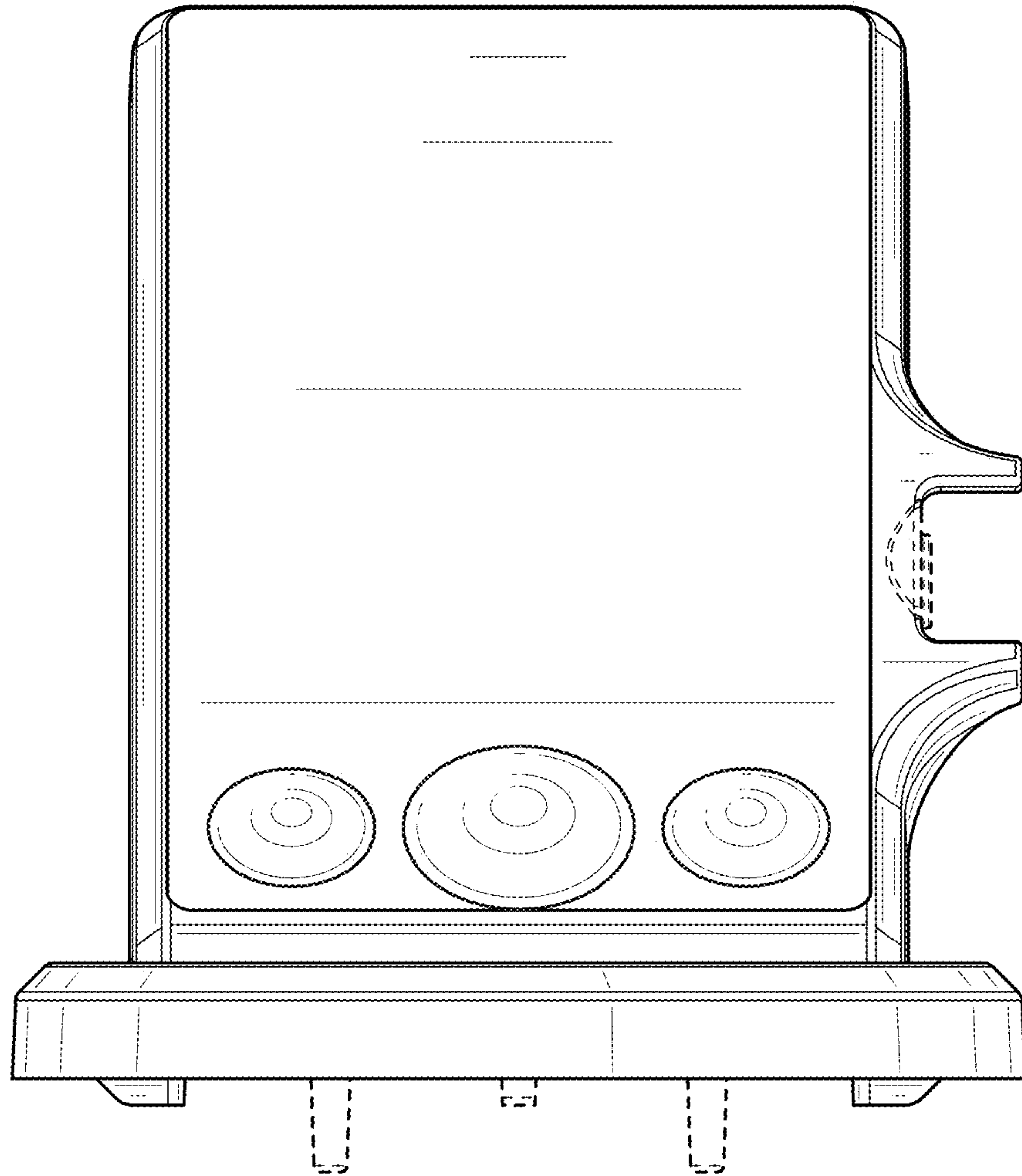

FIG. 7

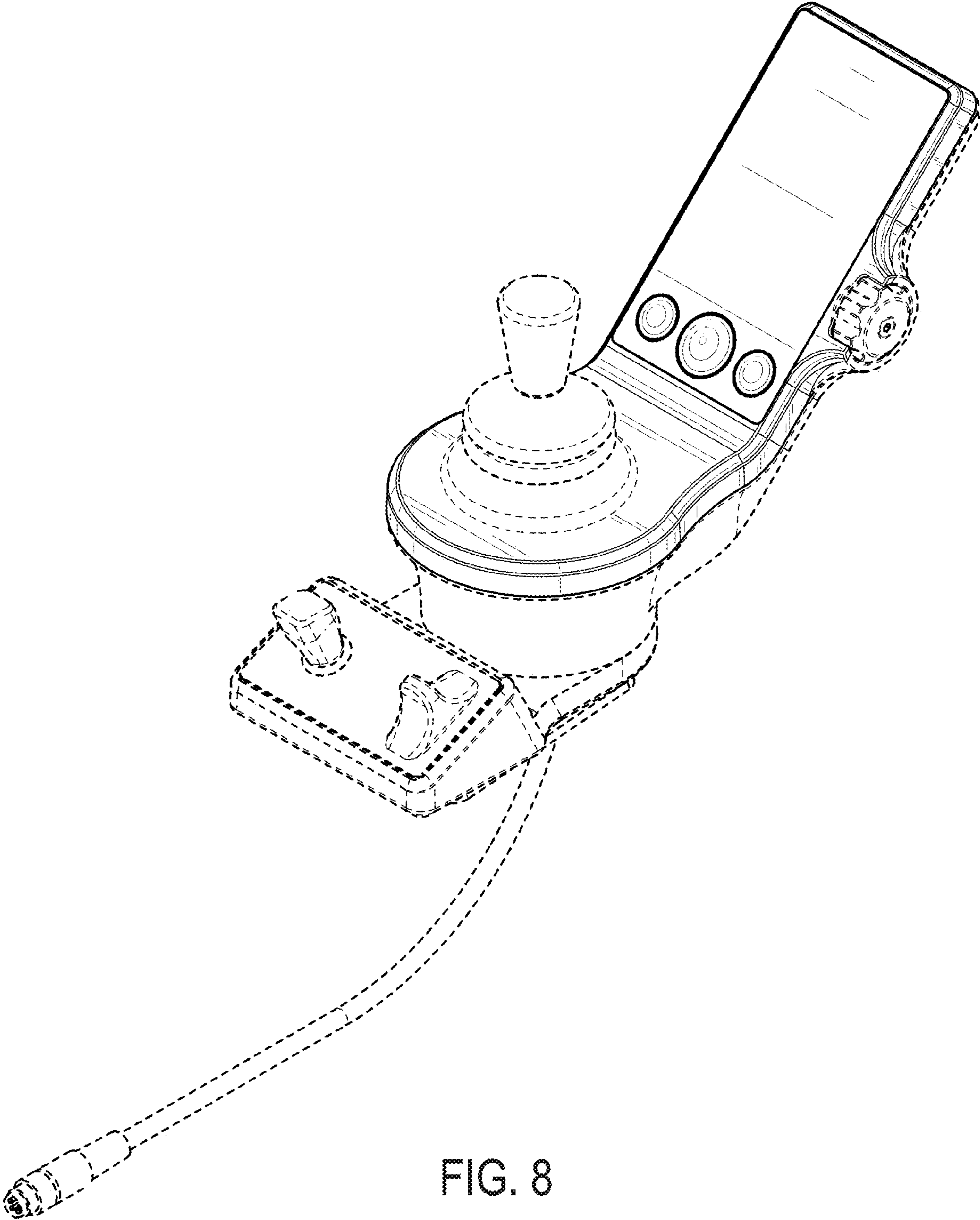

FIG. 8