



US00D876952S

(12) **United States Design Patent**  
**Ramsey**

(10) **Patent No.:** **US D876,952 S**  
(45) **Date of Patent:** **\*\* Mar. 3, 2020**

(54) **BEVERAGE CAN TAB**

(71) Applicant: **Crown Packaging Technology, Inc.**,  
Alsip, IL (US)

(72) Inventor: **Christopher Paul Ramsey**, Wantage  
(GB)

(73) Assignee: **Crown Packaging Technology, Inc.**,  
Alsip, IL (US)

(\*\*) Term: **15 Years**

(21) Appl. No.: **29/665,538**

(22) Filed: **Oct. 4, 2018**

**Related U.S. Application Data**

(62) Division of application No. 29/615,610, filed on Aug.  
30, 2017, now Pat. No. Des. 850,910.

(30) **Foreign Application Priority Data**

Mar. 2, 2017 (EM) ..... 003780642-0001  
Mar. 2, 2017 (EM) ..... 003780642-0002

(Continued)

(51) **LOC (12) Cl.** ..... **09-07**

(52) **U.S. Cl.**  
USPC ..... **D9/438**

(58) **Field of Classification Search**  
USPC ..... D3/202, 242, 318; D7/321, 387, 392,  
D7/392.1, 396.2, 397, 398, 509-511, 629;

(Continued)

(56) **References Cited**

**U.S. PATENT DOCUMENTS**

D199,703 S 12/1964 Potts  
D202,939 S 11/1965 Frazee

(Continued)

**OTHER PUBLICATIONS**

Beverage Daily. CrownSmart uses scannable codes under can tabs to give insight into consumer behavior by Rachel Arthur. Nov. 19, 2015. <URL:https://www.beveragedaily.com/Article/2015/11/19/CrownSmart-uses-scannable-codes-under-can-tabs-to-give-insight-into-consumer-behaviour>. (Year: 2015).\*

(Continued)

*Primary Examiner* — Darcey E Gottschalk

(74) *Attorney, Agent, or Firm* — BakerHostetler

(57) **CLAIM**

I claim the ornamental design for a beverage can tab, as shown and described.

**DESCRIPTION**

FIG. 1 is a top perspective view of a beverage can tab according to a first embodiment of my new design; FIG. 2 is a bottom perspective view thereof; FIG. 3 is a top plan view thereof; FIG. 4 is a bottom plan view thereof; FIG. 5 is a front elevation view thereof; FIG. 6 is a back elevation view thereof; FIG. 7 is a left side elevation view thereof, a right side elevation view being a mirror image of the left side elevation view; FIG. 8 is a top perspective view of a beverage can tab according to a second embodiment of my new design; FIG. 9 is a bottom perspective view thereof; FIG. 10 is a top plan view thereof; FIG. 11 is a bottom plan view thereof; FIG. 12 is a front elevation view thereof; FIG. 13 is a back elevation view thereof; and, FIG. 14 is a left side elevation view thereof, a right side elevation view being a mirror image of the left side elevation view.

**1 Claim, 14 Drawing Sheets**

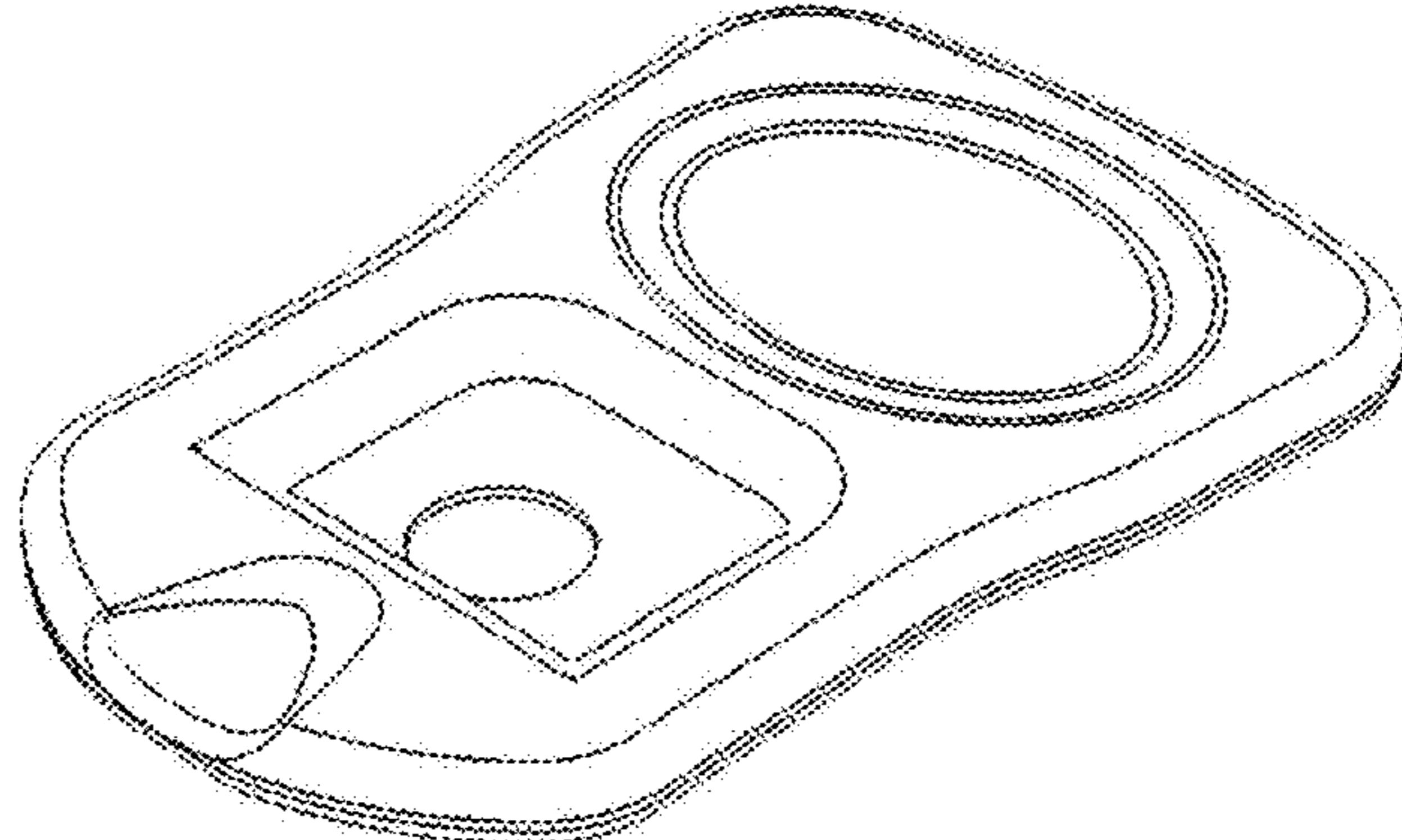
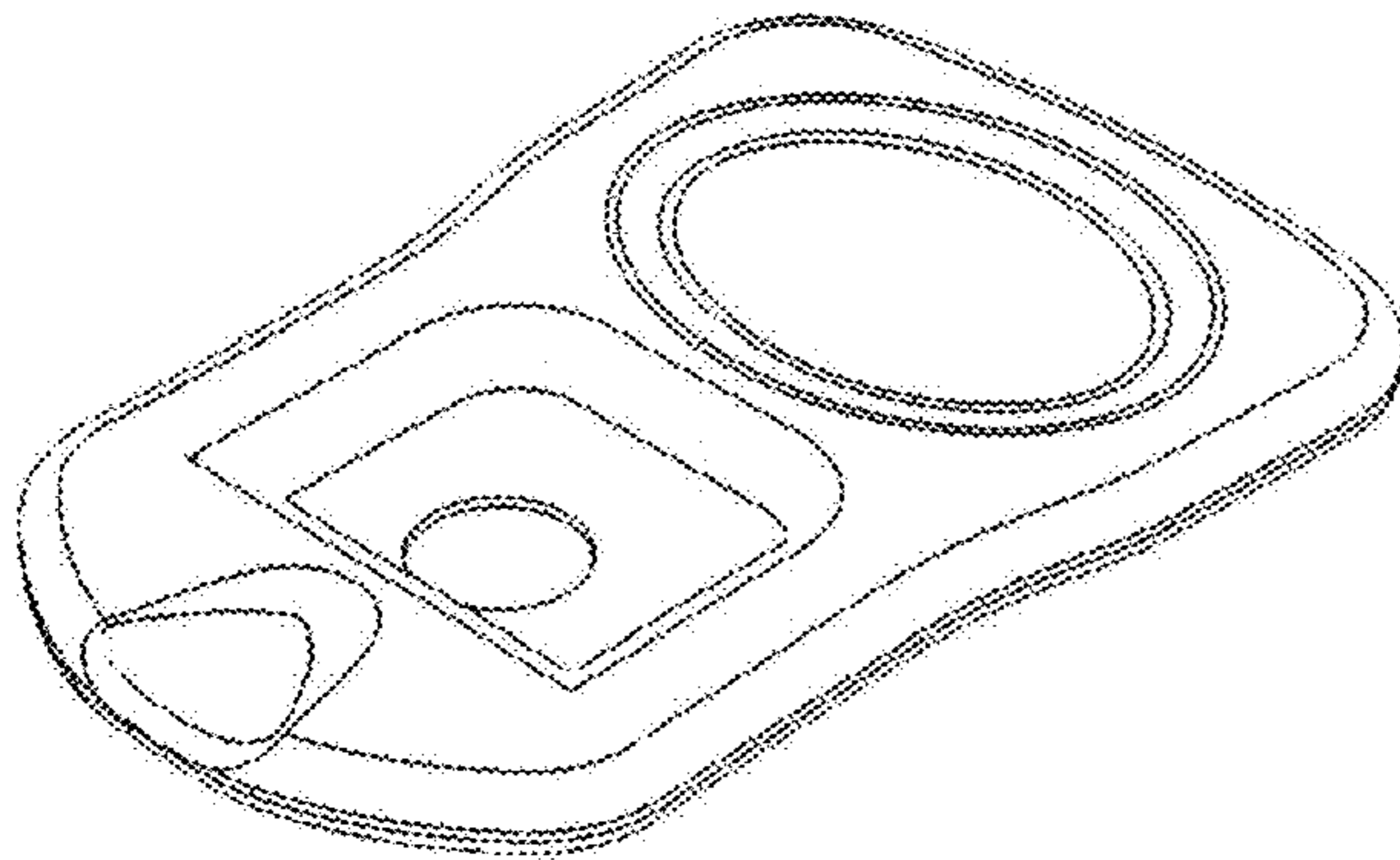

(30) **Foreign Application Priority Data**

Mar. 2, 2017 (EM) ..... 003780642-0003  
 Mar. 2, 2017 (EM) ..... 003780642-0004  
 Mar. 2, 2017 (EM) ..... 003780642-0005  
 Mar. 2, 2017 (EM) ..... 003780642-0006  
 Mar. 2, 2017 (EM) ..... 003780642-0007  
 Mar. 2, 2017 (EM) ..... 003780642-0008

(58) **Field of Classification Search**

USPC ..... D9/434-438, 440, 441, 443, 445-447,  
 D9/449, 499, 667  
 CPC .... B65D 2517/0014; B65D 17/34; B41J 2/47;  
 B23K 26/00  
 See application file for complete search history.

(56) **References Cited**

U.S. PATENT DOCUMENTS

3,499,573 A \* 3/1970 Adams ..... B65D 17/163  
 220/271  
 4,286,728 A \* 9/1981 Frazee ..... B65D 17/4012  
 220/270  
 D261,364 S 10/1981 Smyth  
 D261,867 S \* 11/1981 Hasegawa ..... D9/438  
 D262,607 S \* 1/1982 Drolen, Jr. .... D9/438  
 D269,251 S \* 6/1983 Frazee ..... D9/438  
 D272,607 S \* 2/1984 Hasegawa ..... D9/438  
 D406,236 S \* 3/1999 Brifcani ..... D9/438  
 D530,605 S 10/2006 Huckel

D533,060 S 12/2006 Huckel  
 D702,723 S 4/2014 Abratowski  
 D712,299 S 9/2014 DiPietro  
 D731,311 S 6/2015 Ramsey  
 D732,954 S 6/2015 Ramsey  
 D741,361 S 10/2015 Cornish  
 9,225,822 B2 12/2015 Davis  
 9,278,776 B2 3/2016 Ramsey  
 9,302,830 B2 4/2016 Ramsey  
 D769,296 S 10/2016 Grecia  
 D776,530 S \* 1/2017 Ramsey ..... D9/438  
 D799,267 S 10/2017 Luo  
 D803,052 S 11/2017 Senter  
 D810,503 S 2/2018 Murosky  
 D850,910 S 6/2019 Ramsey  
 2012/0024967 A1 2/2012 Chen  
 2013/0075296 A1 3/2013 Ramsey  
 2013/0270269 A1 10/2013 Lewis  
 2016/0332772 A1 \* 11/2016 Ramsey ..... B65D 17/4012

OTHER PUBLICATIONS

Best in Packaging. Reclosable Cans and the Can End as Marketing Tool by Anton Steeman. Oct. 26, 2012. <URL:https://bestinpackaging.com/2012/10/26/reclosable-cans-and-the-can-end-as-marketing-tool/>. (Year: 2012).\*  
 iOS Rider, "How to Scan QR codes from iPhone and iPad with iOS 11", http://iosrider.com/how-use-qr-codes-ios-iphone-ipad/, Oct. 17, 2017, 3 pages.

\* cited by examiner

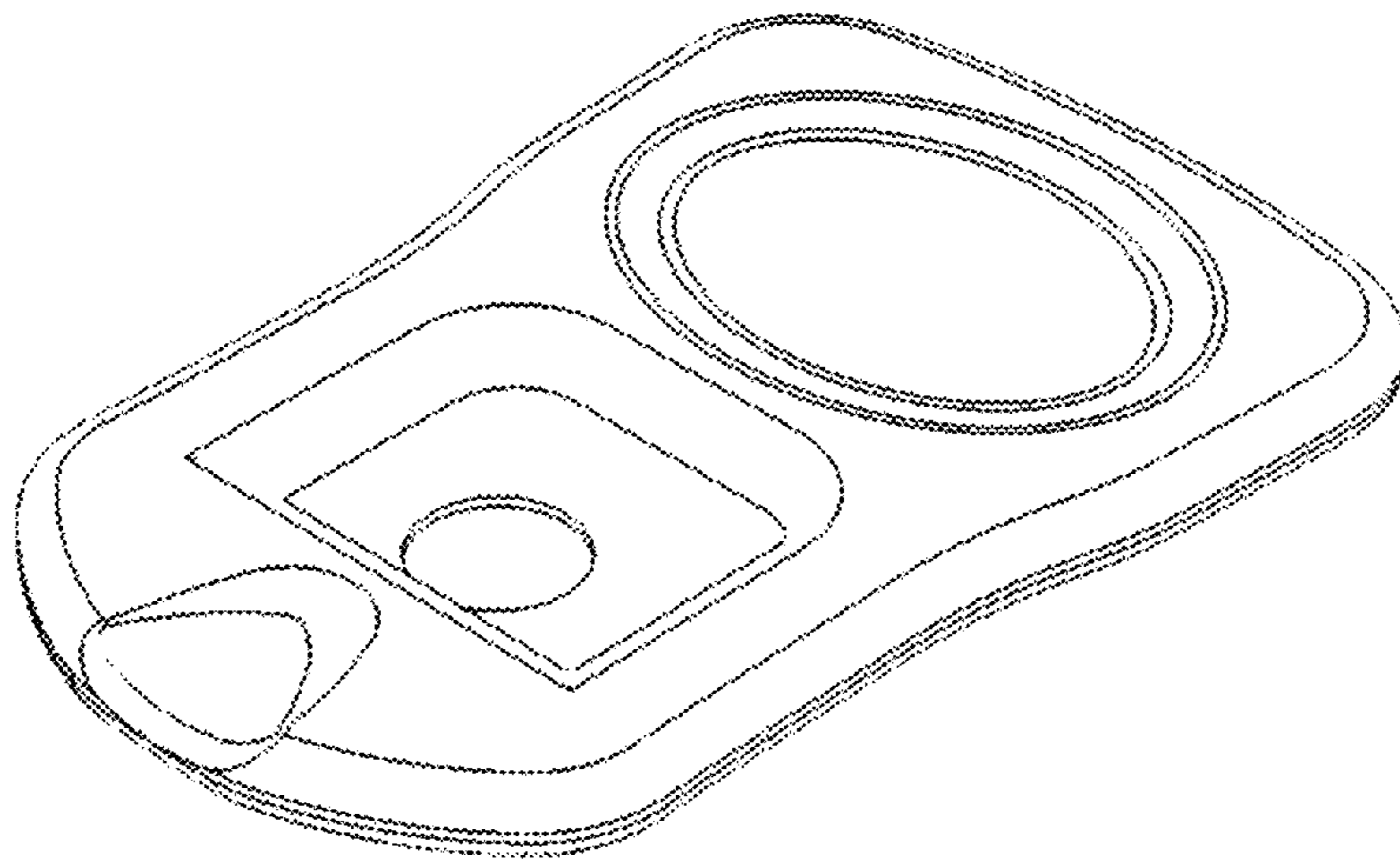

FIG. 1

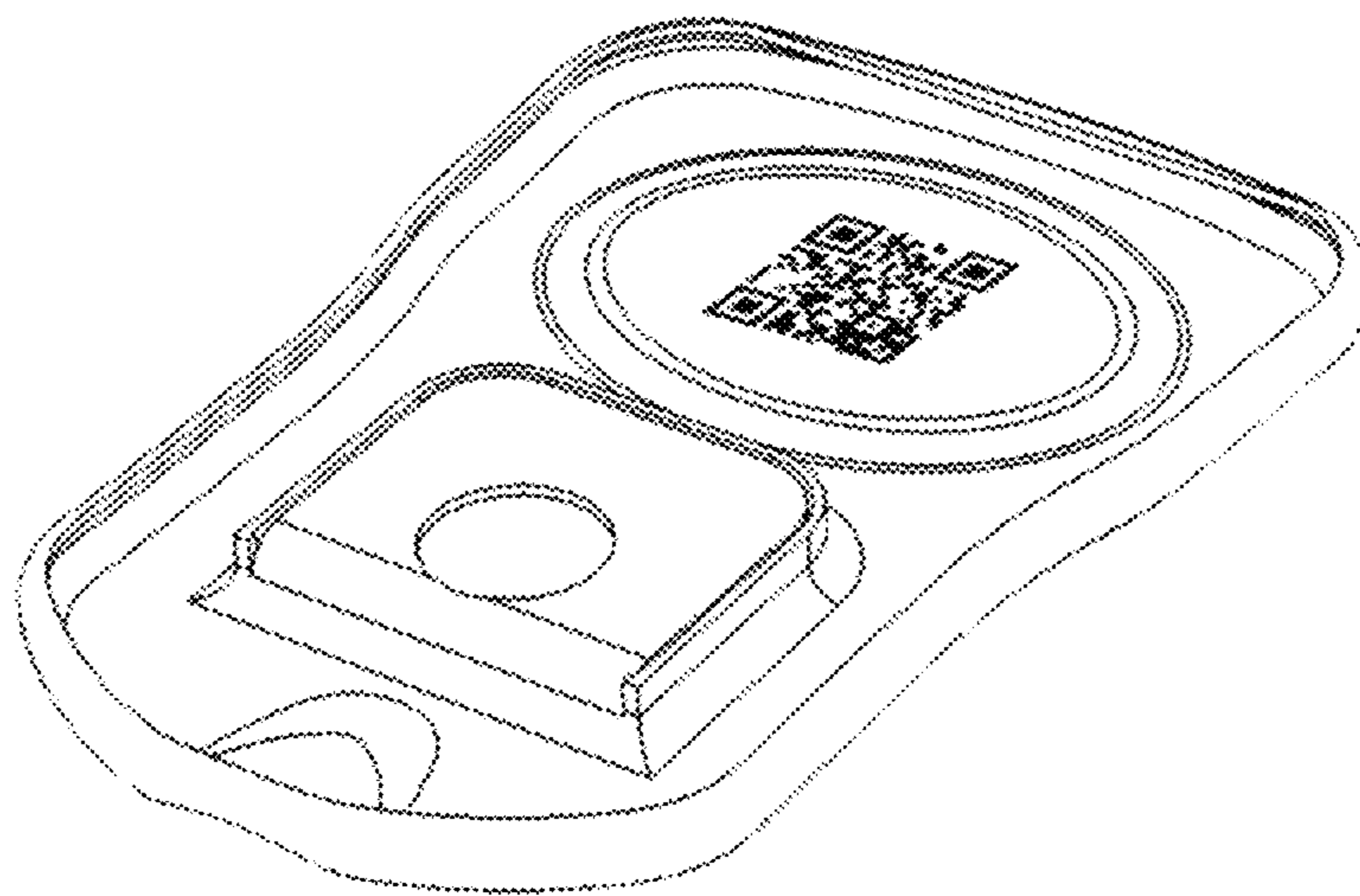

FIG. 2



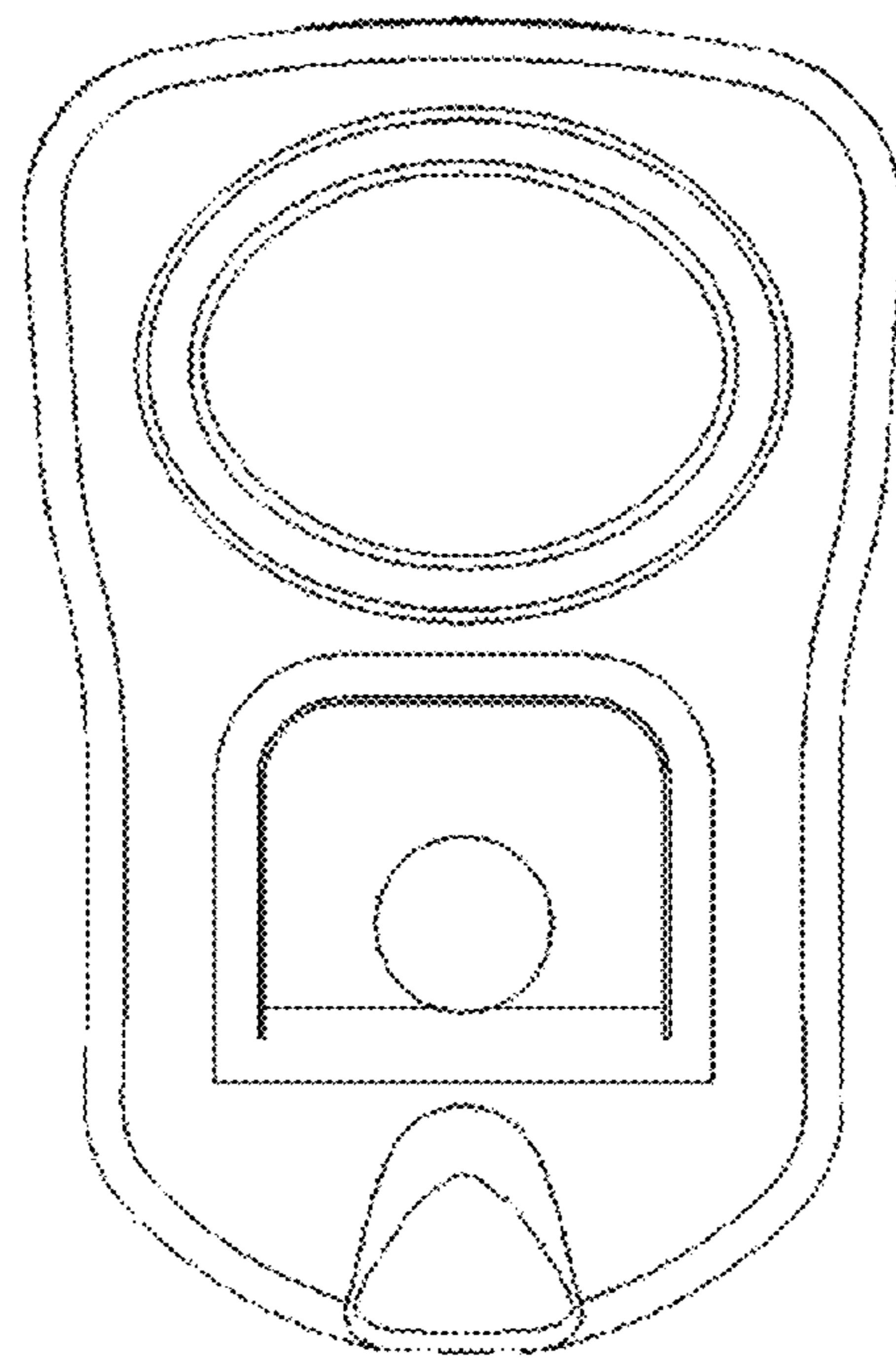

FIG. 3

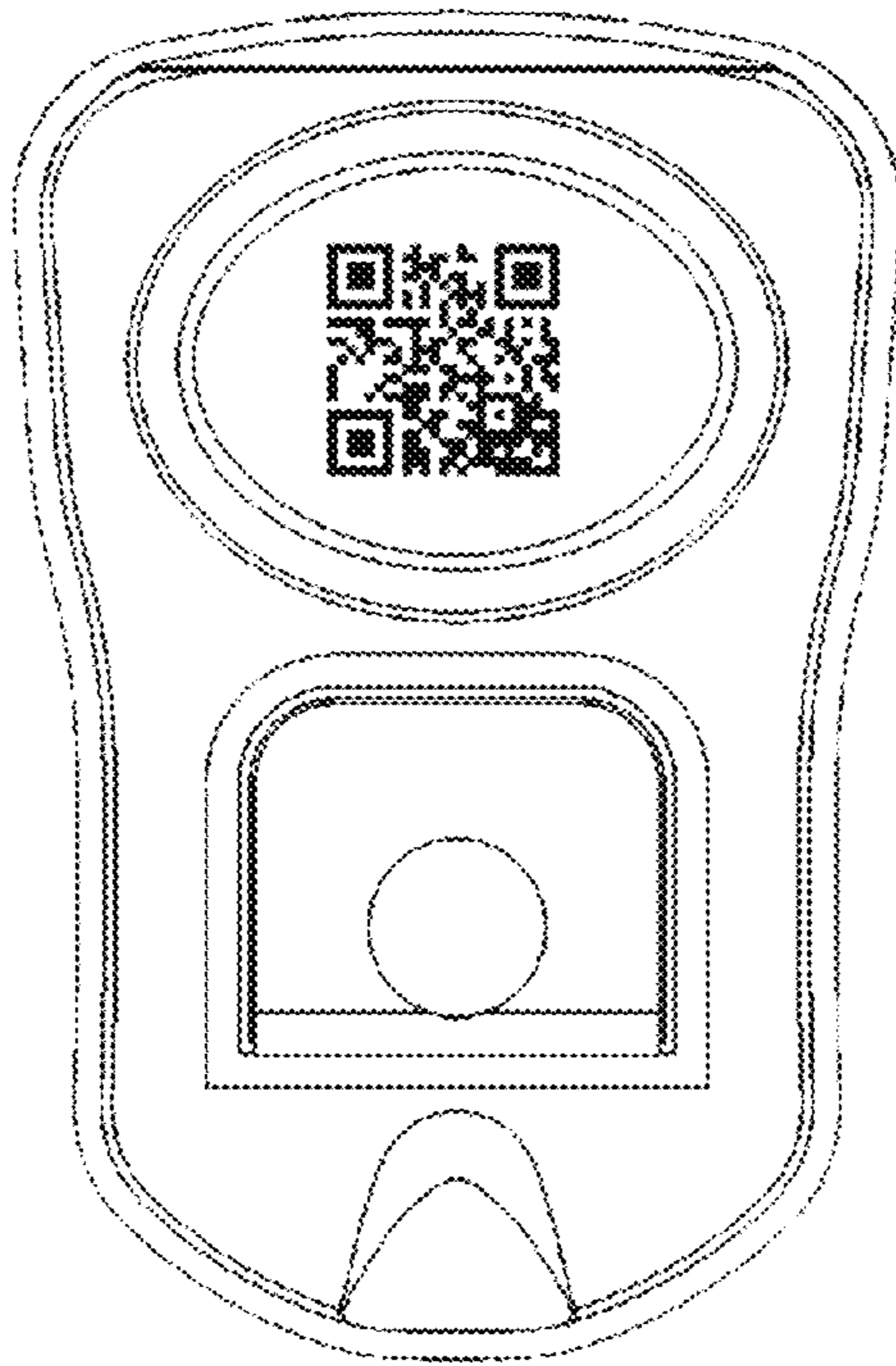

FIG. 4



FIG. 5

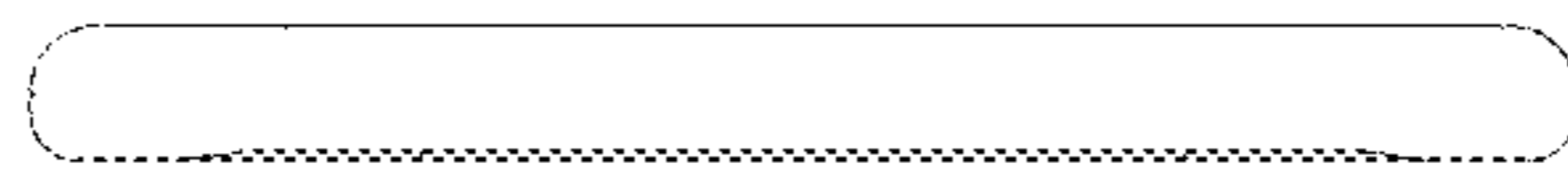

FIG. 6





FIG. 7

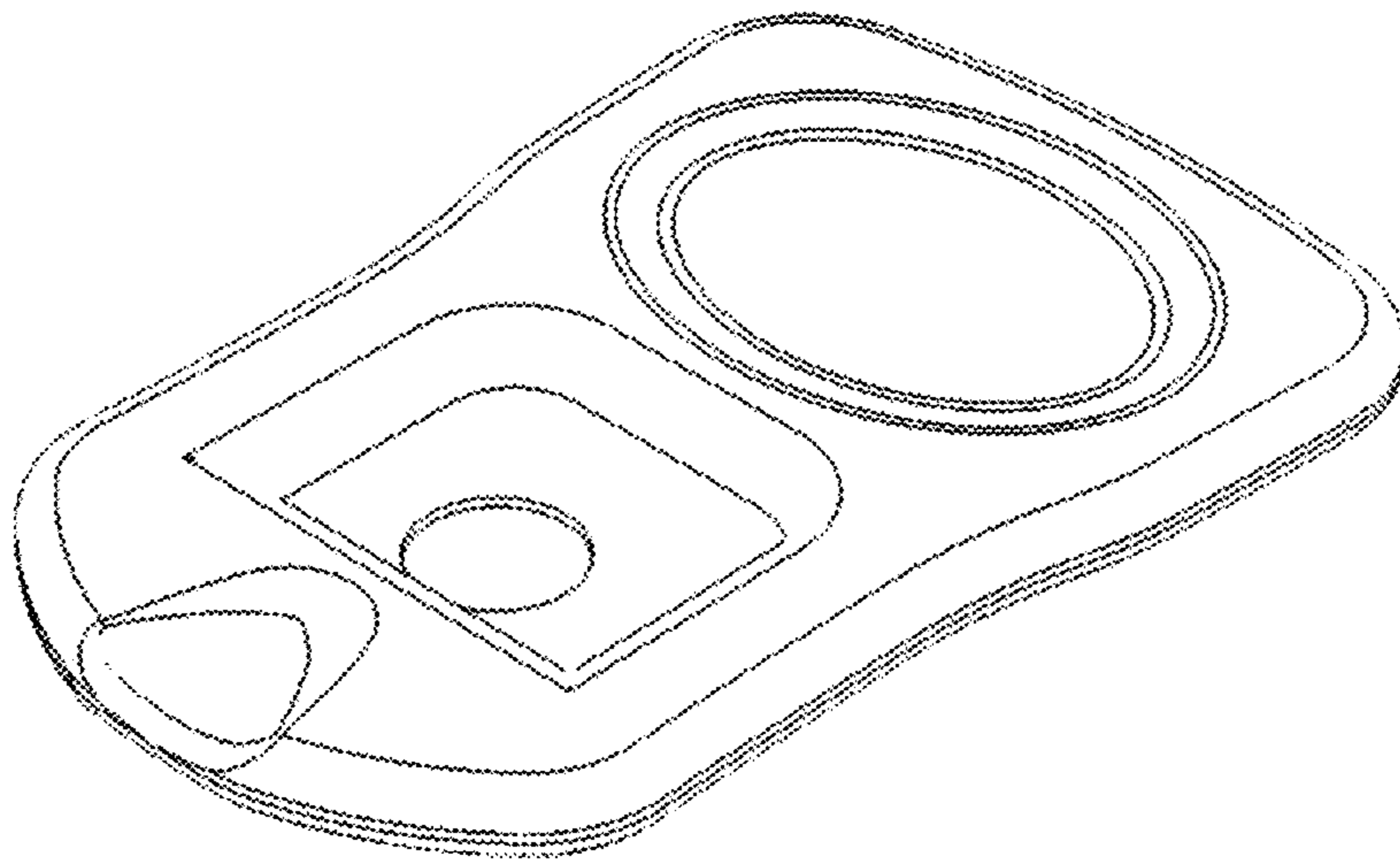

FIG. 8

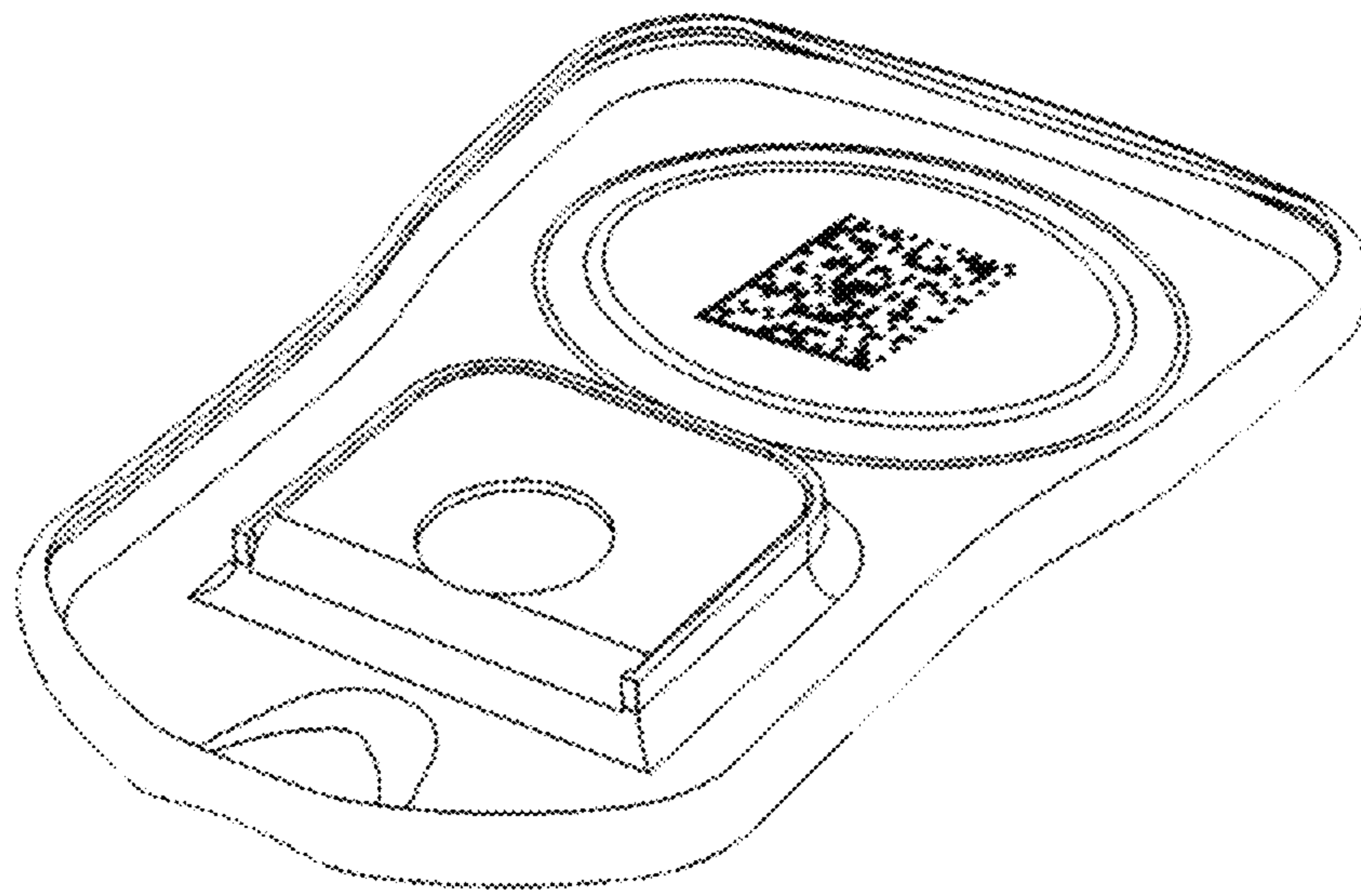

FIG. 9

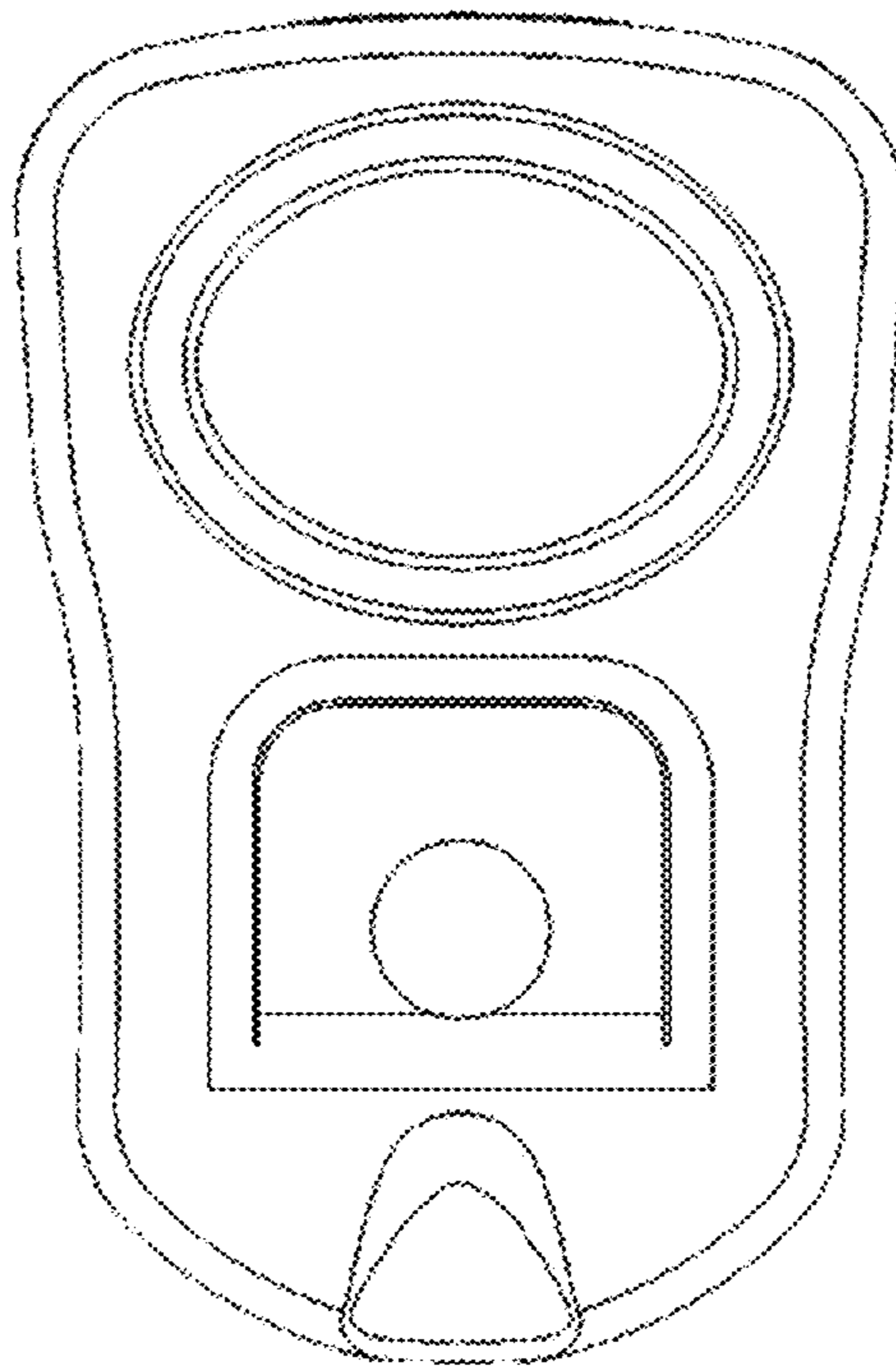

FIG. 10

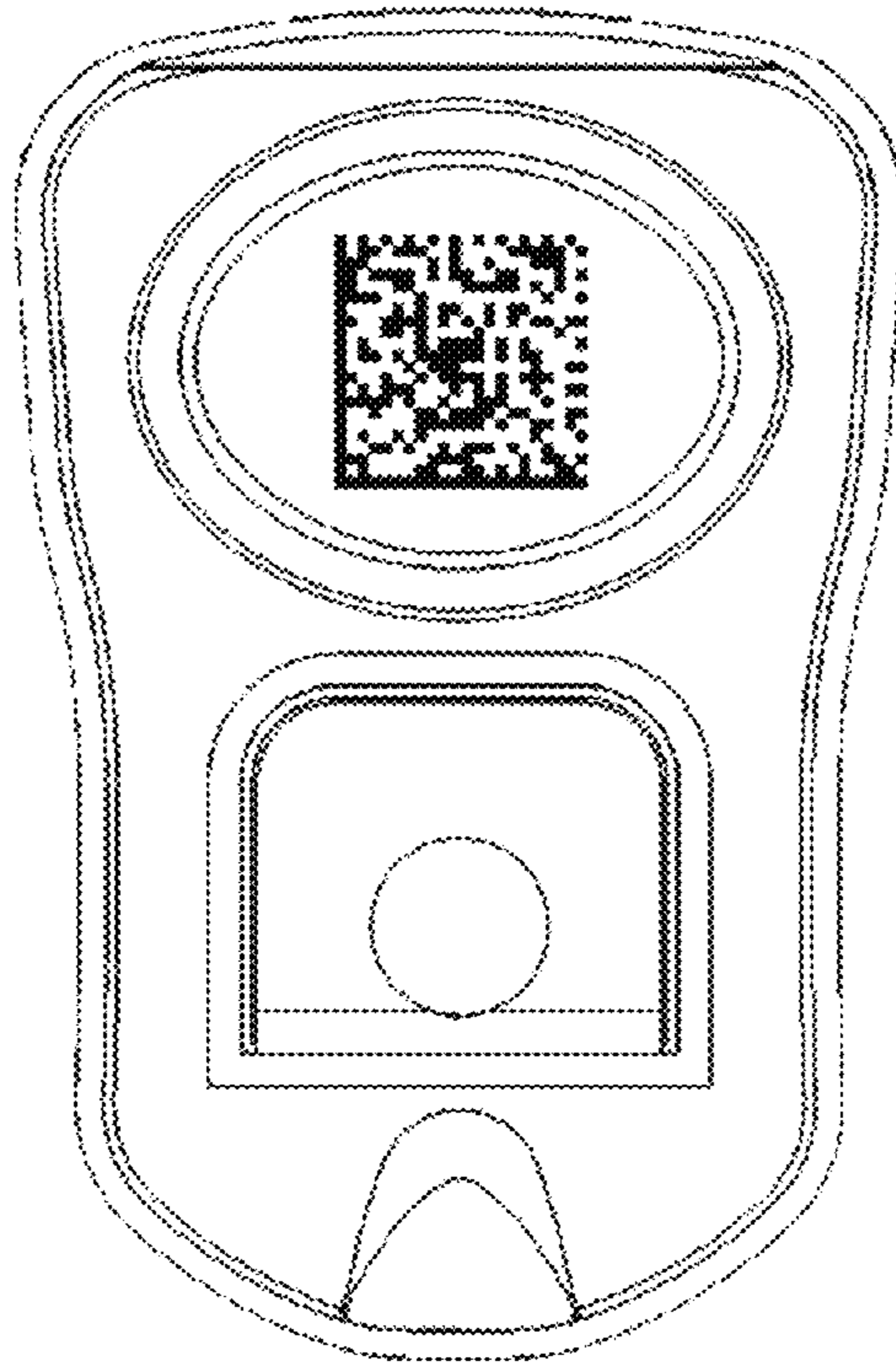

FIG. 11

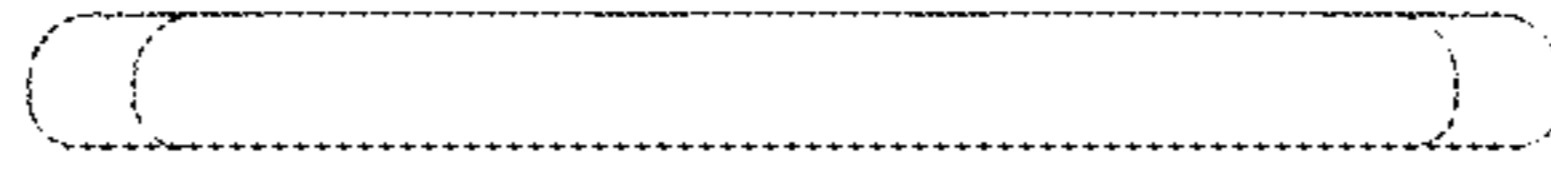

FIG. 12





FIG. 13



FIG. 14