



US00D87669S

(12) **United States Design Patent**
Månsson

(10) **Patent No.:** **US D876,669 S**

(45) **Date of Patent:** **** Feb. 25, 2020**

(54) **PROFILE RAIL**

(71) Applicant: **Movomech AB**, Kristianstad (SE)

(72) Inventor: **Emil Månsson**, Tollarp (SE)

(73) Assignee: **MOVOMECH AB**, Kristianstad (SE)

(**) Term: **15 Years**

(21) Appl. No.: **29/653,549**

(22) Filed: **Jun. 15, 2018**

(30) **Foreign Application Priority Data**

Dec. 22, 2017 (EM) 004562098

(51) **LOC (12) Cl.** **25-02**

(52) **U.S. Cl.**
USPC **D25/38.1**

(58) **Field of Classification Search**
USPC D25/119-125, 38.1, 48.2; 256/65.02,
256/65.04, 65.07, 65.11, 65.15; 49/130,
49/504, 408, 409, 410; 52/204.1, 204.5,
52/204.51, 656.5, 656.6, 208, 656.2,
52/656.7

CPC E06B 1/36; E06B 3/26301; E06B 1/18;
E06B 3/26343; E06B 3/5427; E06B
3/67339

See application file for complete search history.

(56) **References Cited**

U.S. PATENT DOCUMENTS

D503,484 S * 3/2005 Deleu D25/122
D537,173 S * 2/2007 Westphal D25/124

D572,372 S * 7/2008 Koch B66C 7/02
D25/38.1
D616,568 S * 5/2010 Desrosiers D25/122
D661,813 S * 6/2012 Walker D25/38.1
D734,495 S * 7/2015 Walde D25/38.1
D734,503 S * 7/2015 Massingham D25/124

* cited by examiner

Primary Examiner — Cynthia Ramirez

Assistant Examiner — Gino Colan

(74) *Attorney, Agent, or Firm* — Nixon & Vanderhye P.C.

(57) **CLAIM**

The ornamental design for a profile rail, as shown and described.

DESCRIPTION

FIG. 1 is a perspective view of a profile rail according to a first embodiment;
FIGS. 2 and 3 are side views thereof;
FIG. 4 is an end view thereof, the opposite end being a mirror image;
FIG. 5 is a front view thereof;
FIG. 6 is a rear view thereof;
FIG. 7 is a perspective view of a profile rail according to a second embodiment;
FIG. 8 is an end view thereof, the opposite end being a mirror image;
FIGS. 9 and 10 are side views thereof;
FIG. 11 is a front view thereof; and,
FIG. 12 is a rear view thereof.
The profile rail is shown with a symbolic break in its length. The appearance of any portion of the article between the break lines forms no part of the claimed design.

1 Claim, 12 Drawing Sheets

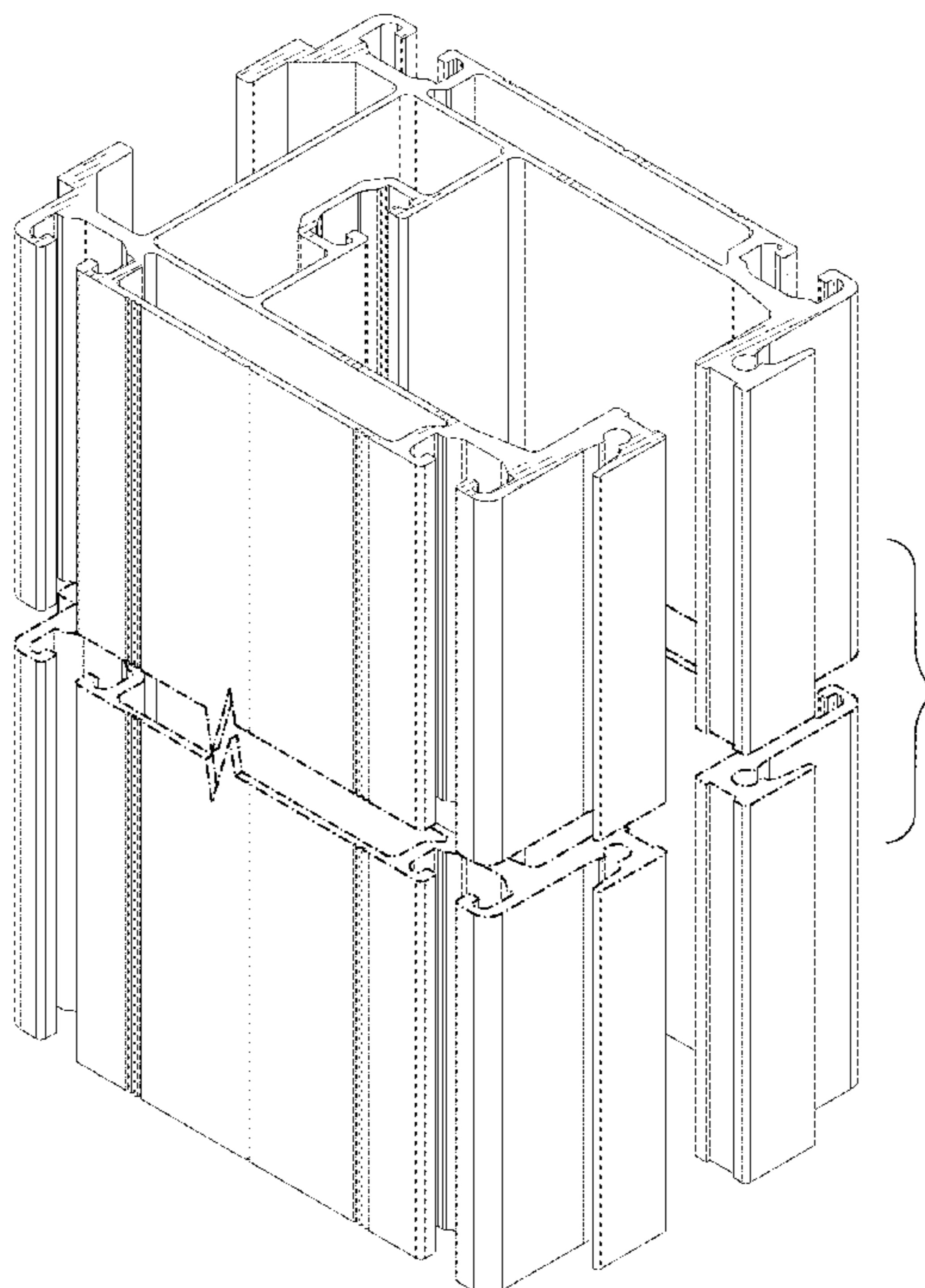

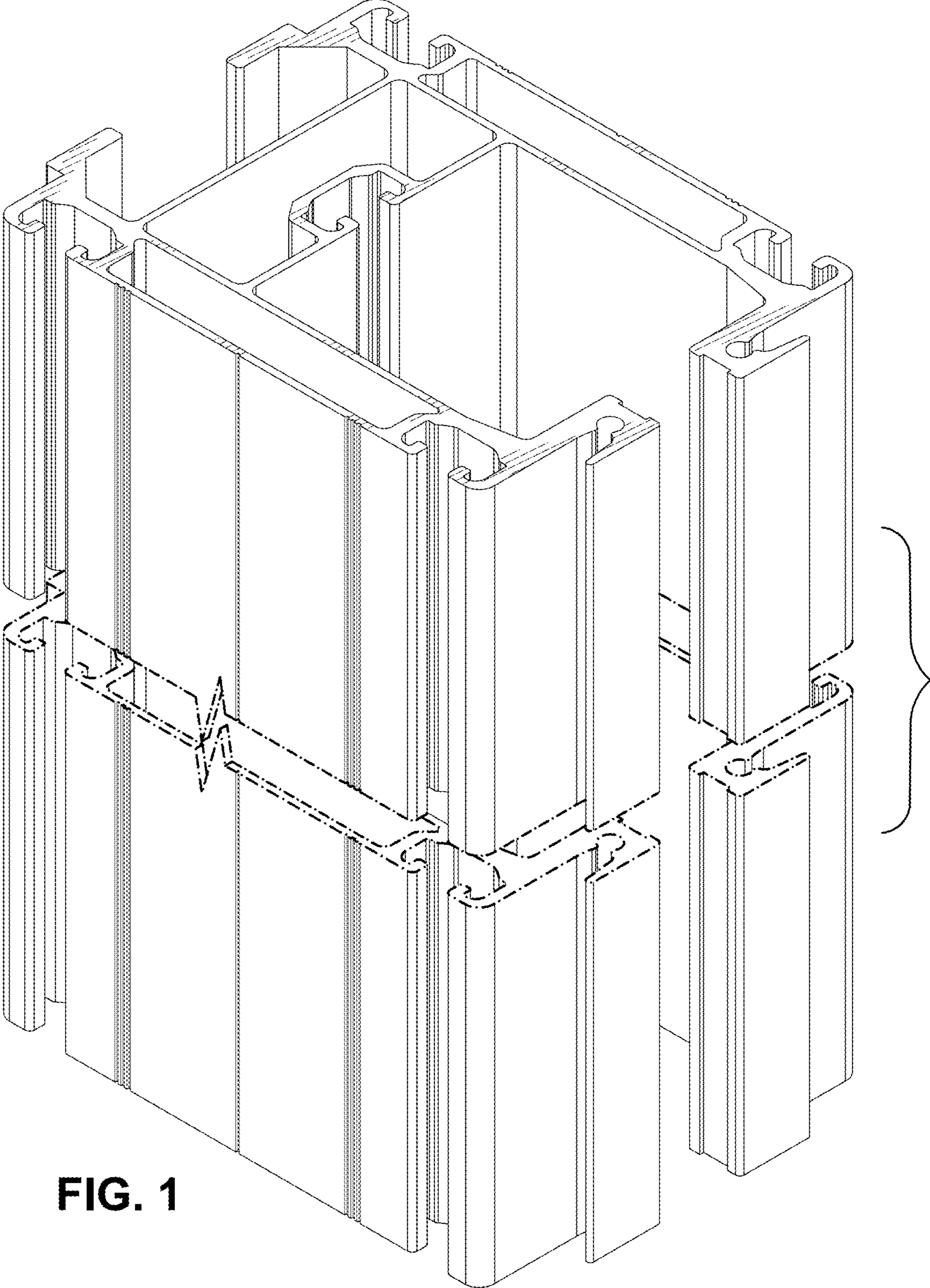

FIG. 1

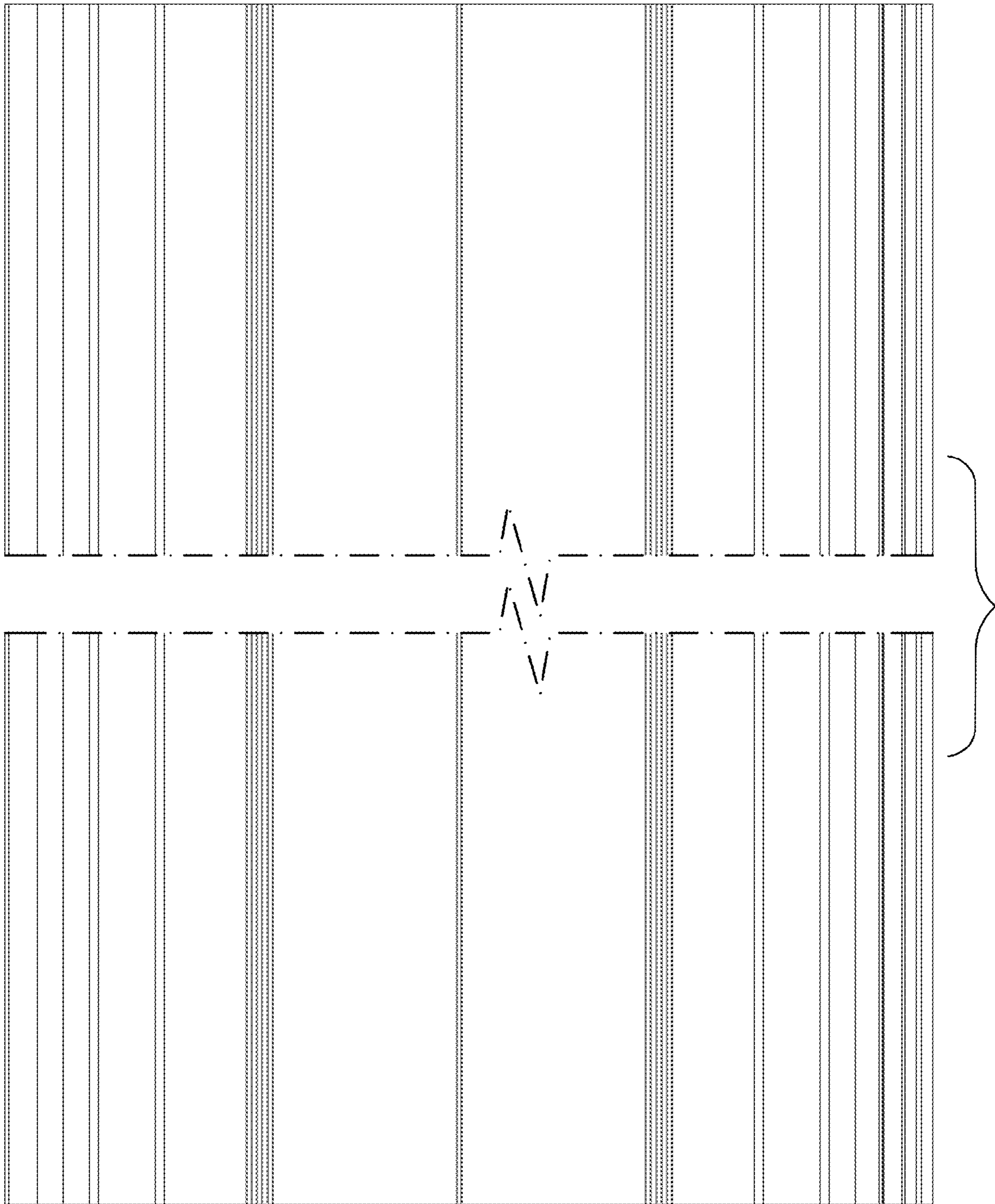

FIG. 2

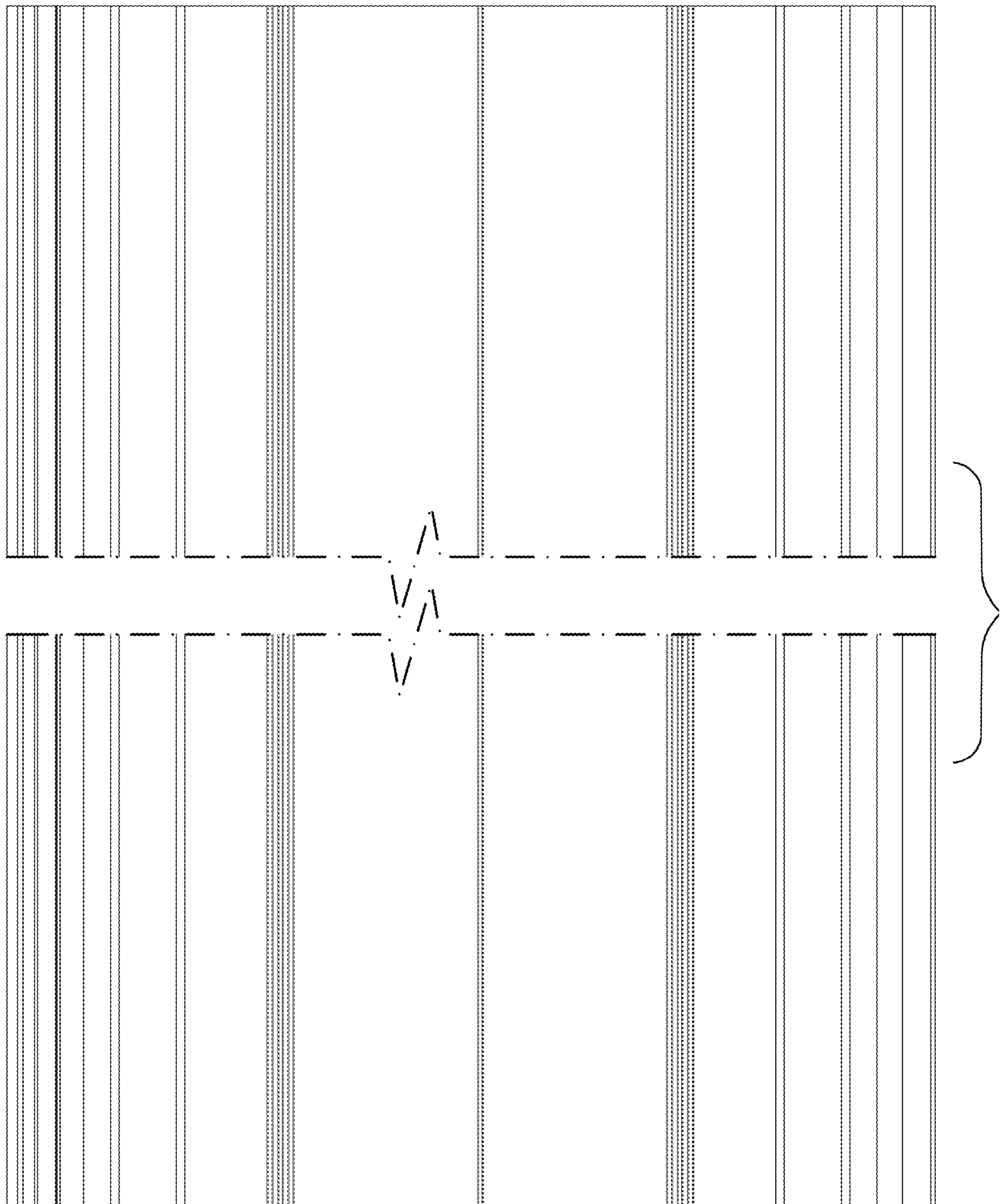

FIG. 3

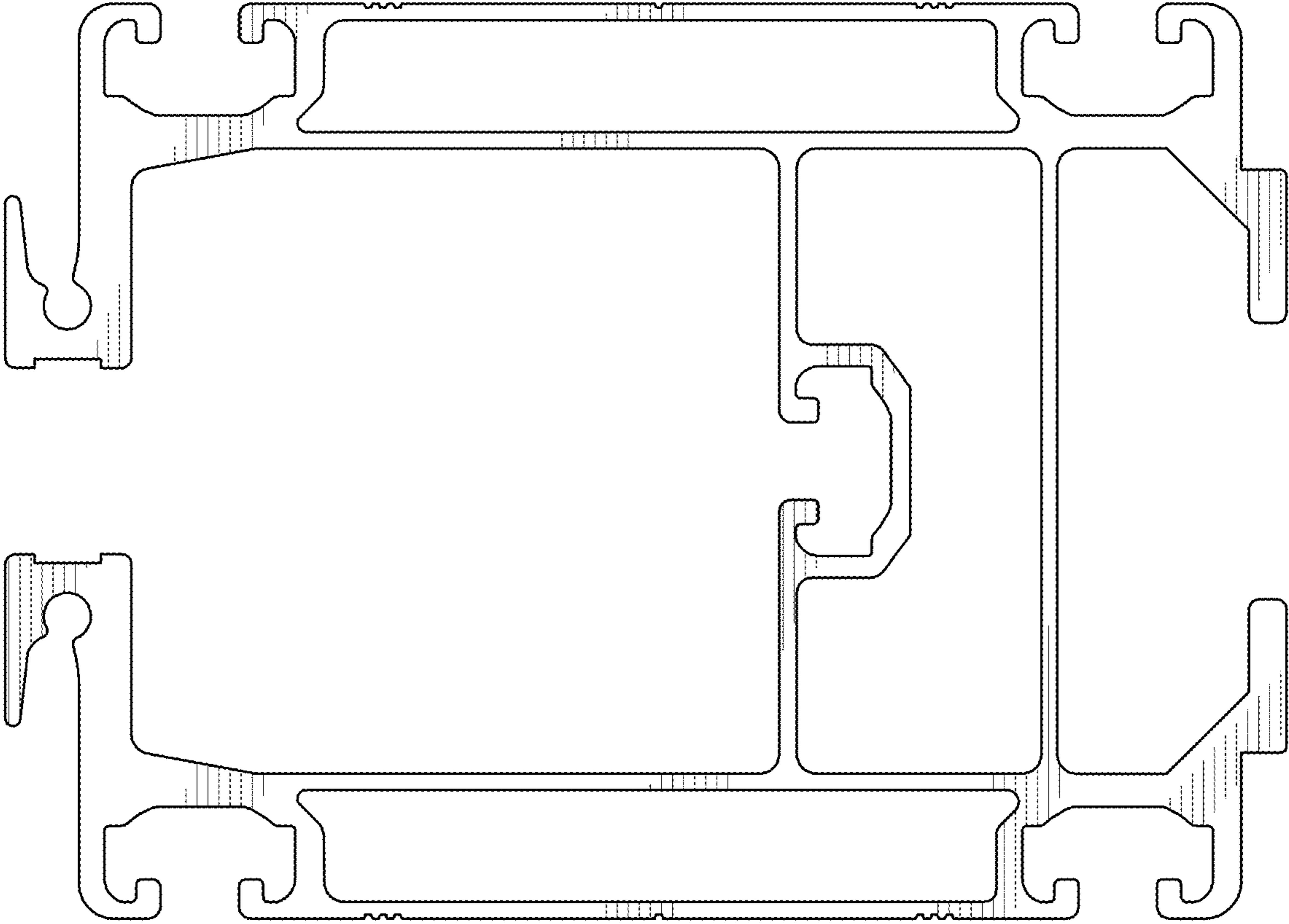

FIG. 4

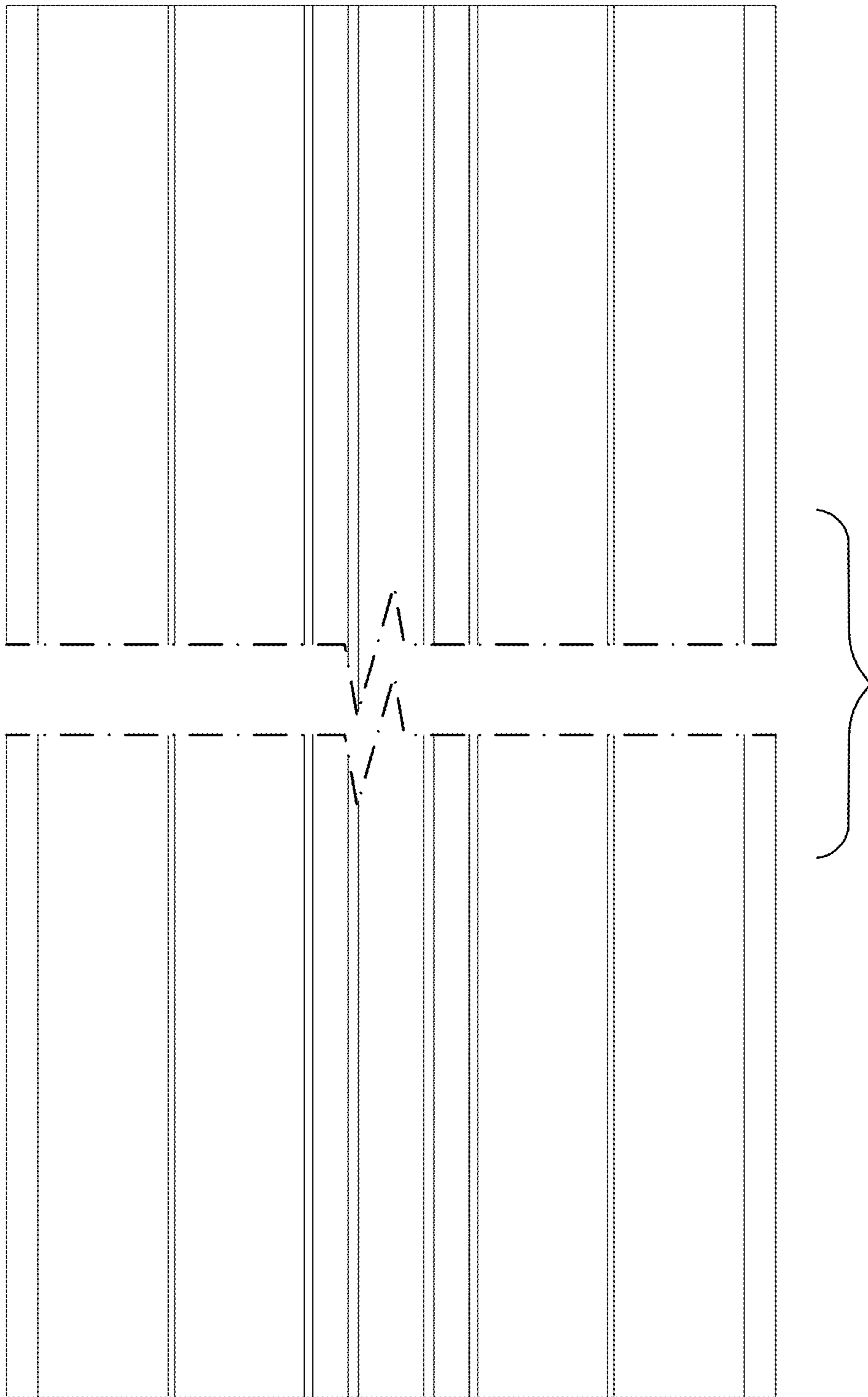

FIG. 5

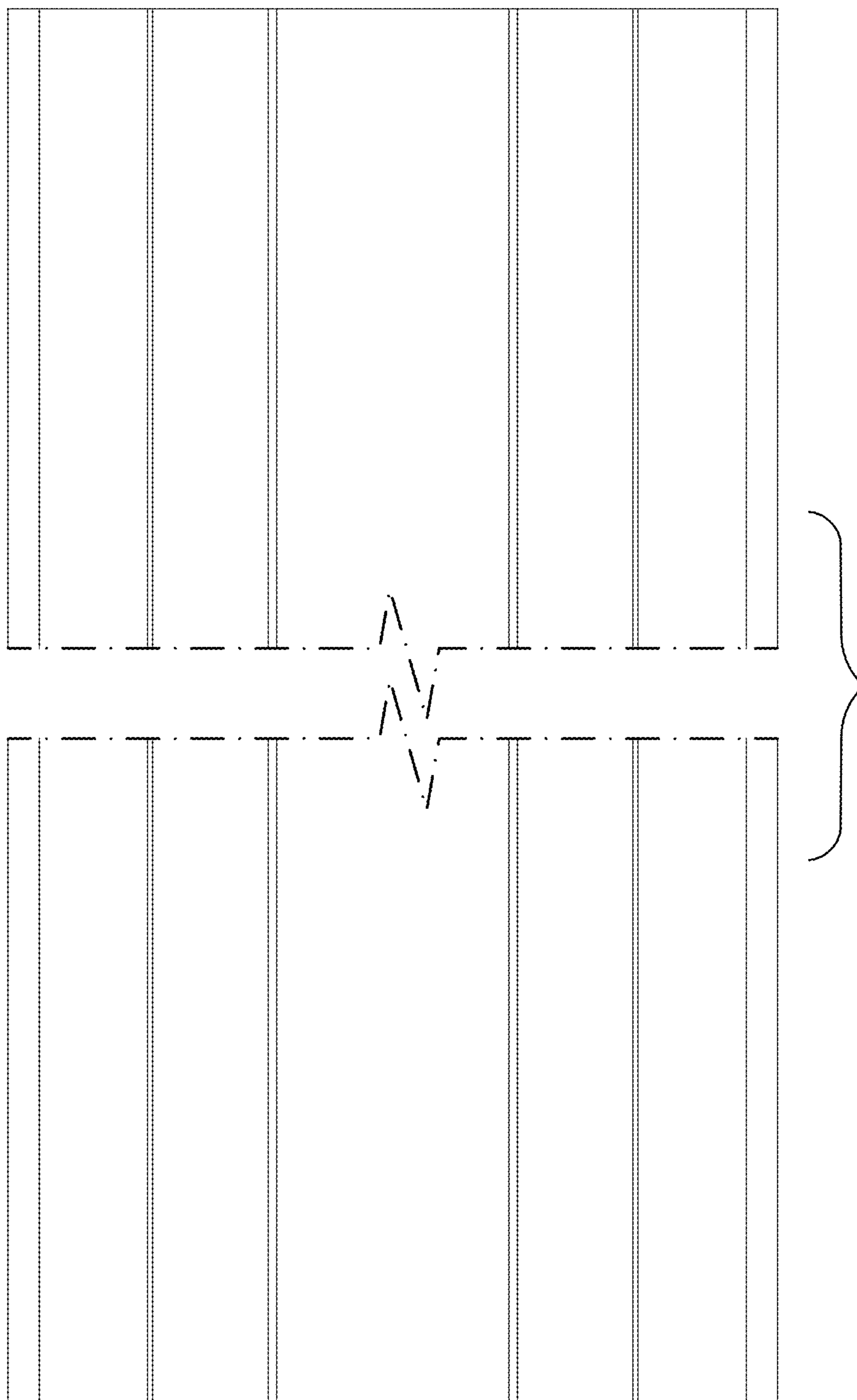

FIG. 6

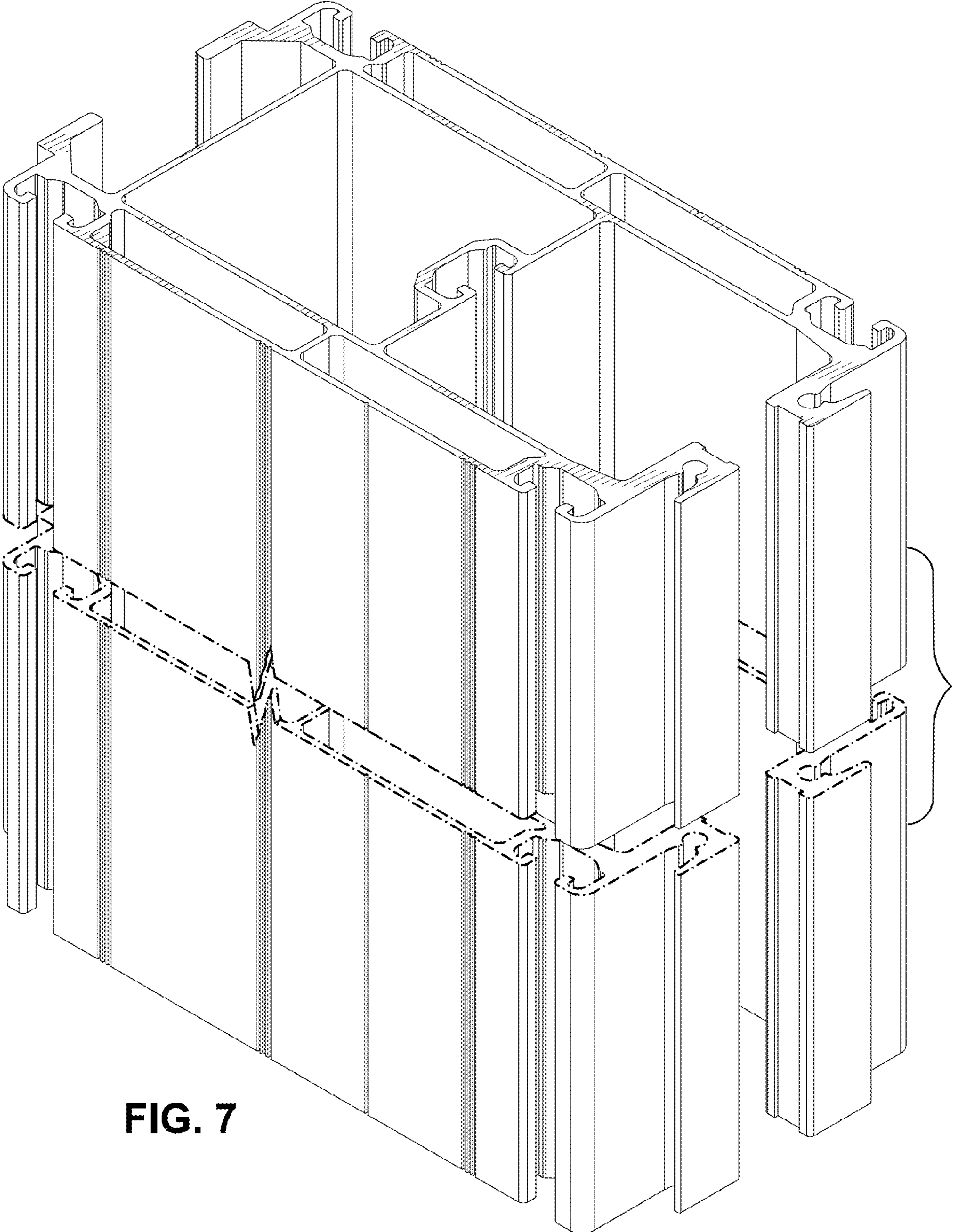

FIG. 7

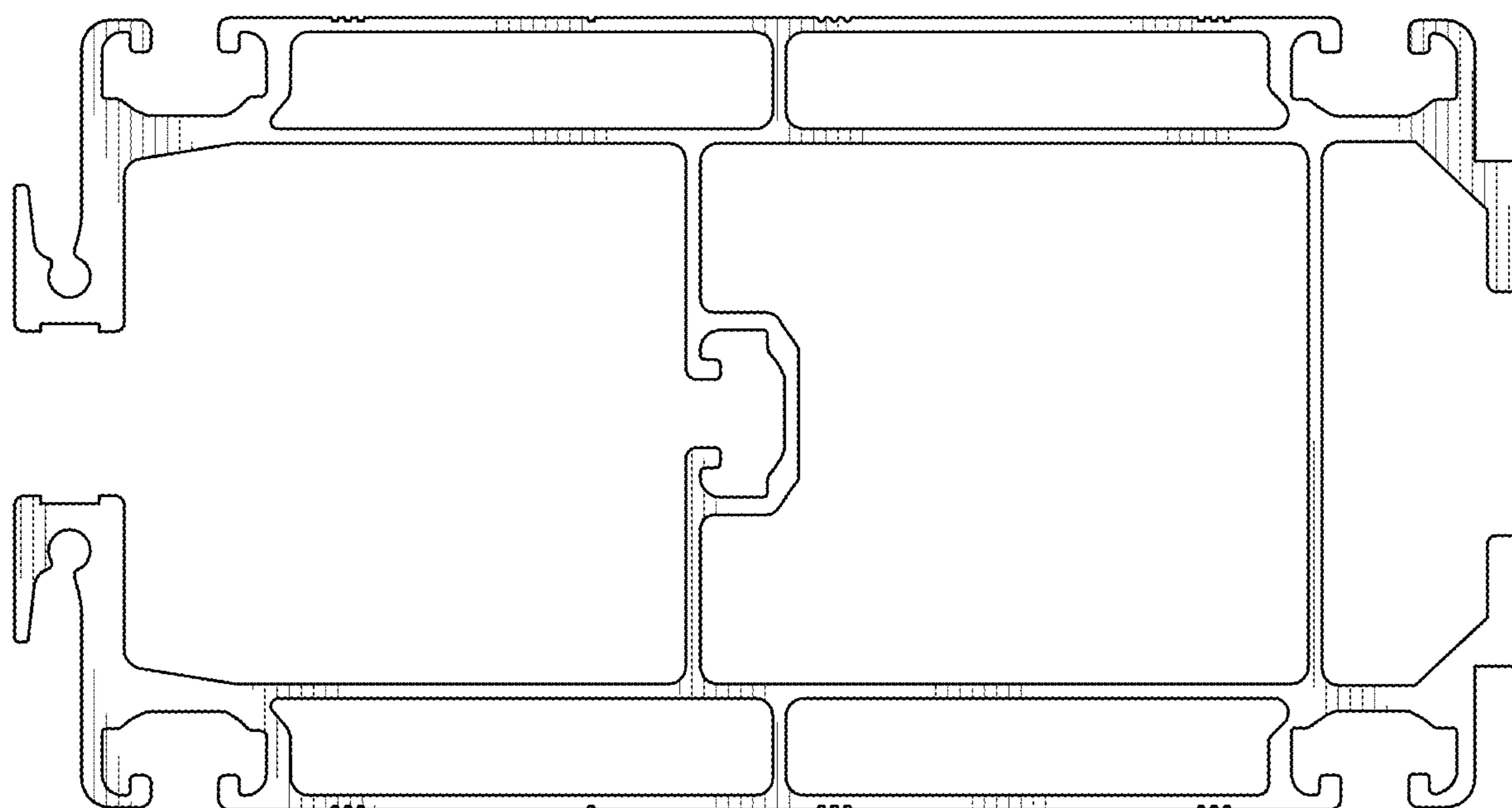

FIG. 8

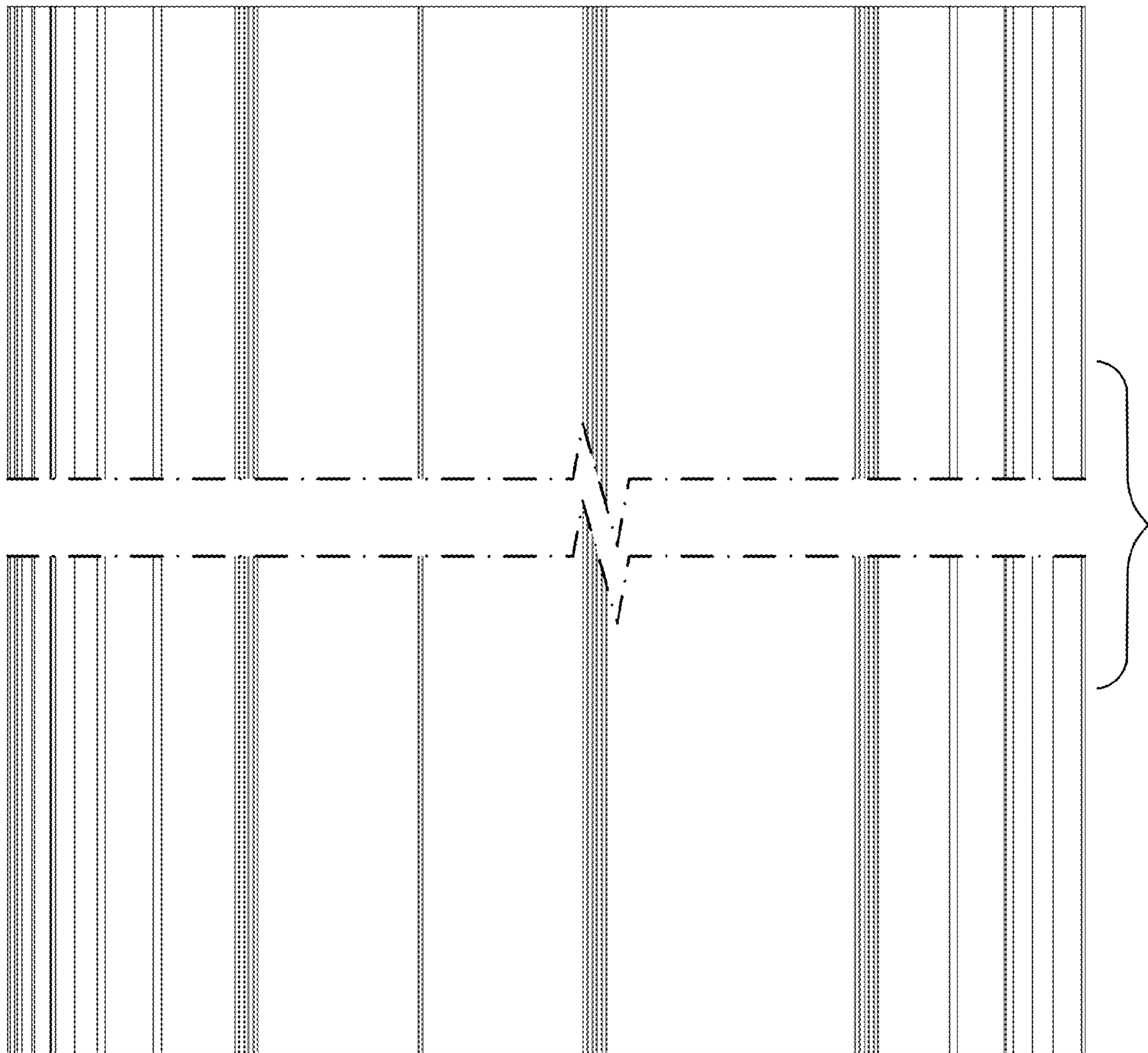

FIG. 9

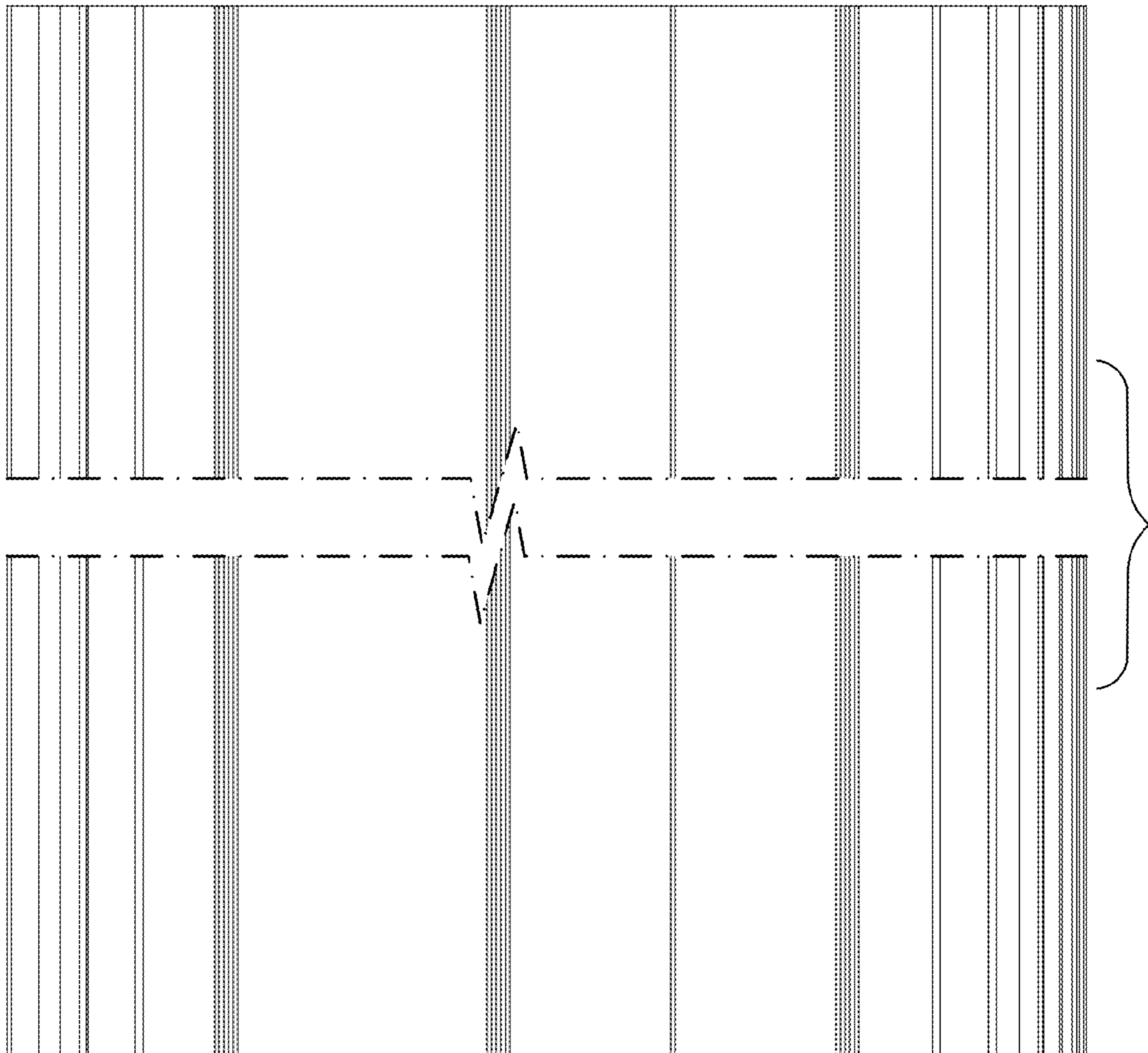

FIG. 10

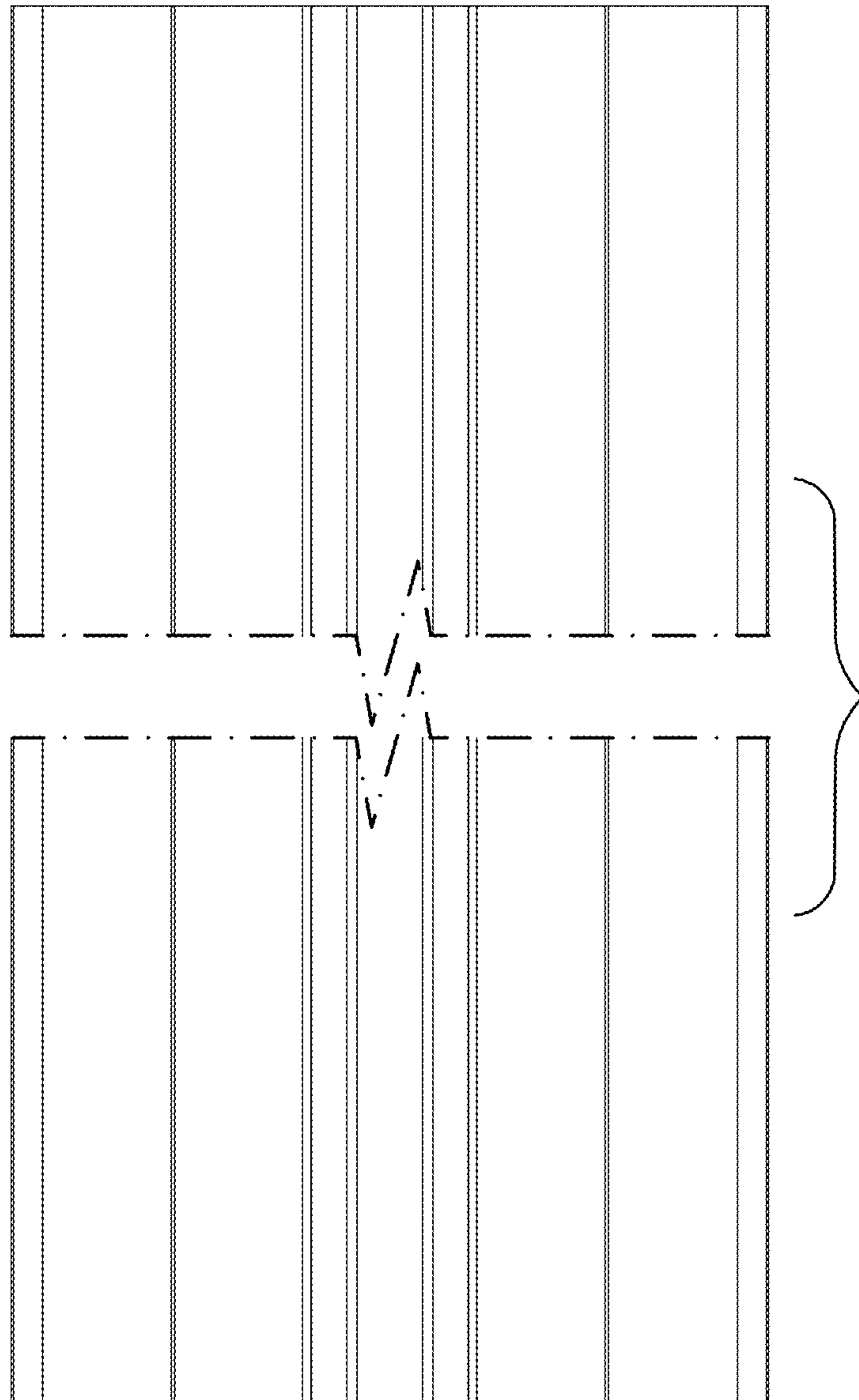

FIG. 11

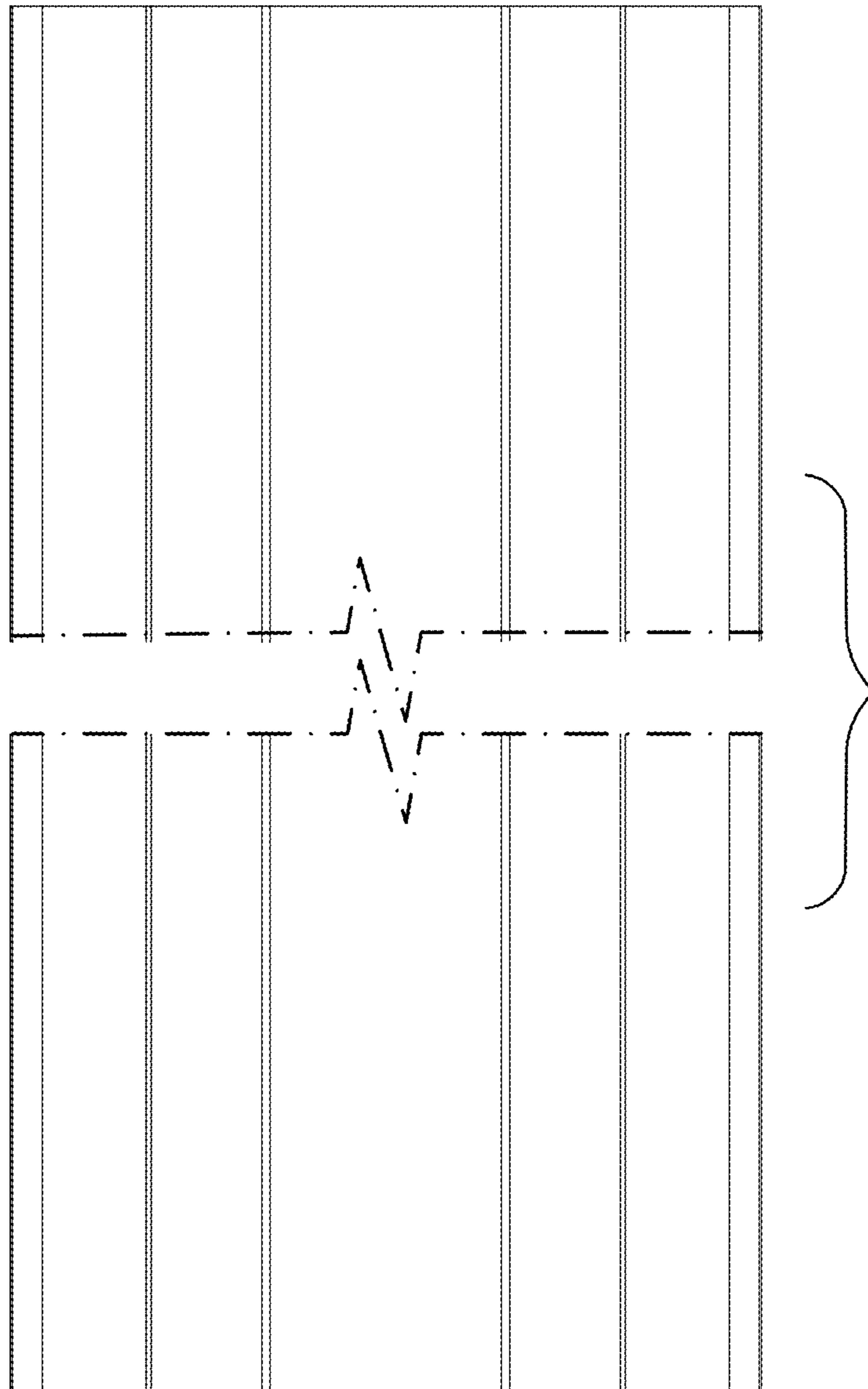

FIG. 12