



US00D876592S

(12) **United States Design Patent**  
**Vaz et al.**

(10) **Patent No.:** **US D876,592 S**  
(45) **Date of Patent:** **\*\* Feb. 25, 2020**

- (54) **FEMALE HOSE COUPLING**
- (71) Applicant: **TEKNOR APEX COMPANY,**  
Pawtucket, RI (US)
- (72) Inventors: **David Vaz,** Riverside, RI (US); **Mark Buchan,** Norton, MA (US)
- (73) Assignee: **TEKNOR APEX COMPANY,**  
Pawtucket, RI (US)
- (\*\*) Term: **15 Years**
- (21) Appl. No.: **29/657,903**
- (22) Filed: **Jul. 26, 2018**
- (51) **LOC (12) Cl.** ..... **23-01**
- (52) **U.S. Cl.**  
USPC ..... **D23/262**
- (58) **Field of Classification Search**  
USPC ..... D23/259, 262–266, 245, 213, 233, 235;  
285/197–200; 137/315.23, 798;  
138/109–110, 155, 96 T; D13/133, 151;  
D8/382, 396  
CPC ..... F16L 37/252; F16L 43/00  
See application file for complete search history.

D575,377 S *	8/2008	Roman	.....	D23/259
D637,697 S *	5/2011	Steiner	.....	D23/262
D648,005 S *	11/2011	Morishita	.....	D23/259
D736,357 S	8/2015	Melo et al.		
D736,358 S	8/2015	Melo et al.		
D736,359 S	8/2015	Melo et al.		
D738,471 S	9/2015	Melo et al.		
D757,233 S	5/2016	Vaz et al.		
D760,363 S *	6/2016	Yang	.....	D23/262
D777,888 S	1/2017	Vaz et al.		
D779,640 S	2/2017	Vaz et al.		
D782,623 S	3/2017	Vaz et al.		
D784,497 S	4/2017	Vaz et al.		
D785,141 S	4/2017	Vaz et al.		
9,810,357 B2 *	11/2017	Blanchette	.....	F16L 33/207
2013/0113205 A1 *	5/2013	Berardi	.....	F16L 11/10 285/123.1

\* cited by examiner

*Primary Examiner* — Amy C Wierenga

(74) *Attorney, Agent, or Firm* — Hudak, Shunk & Farine Co. LPA

(57) **CLAIM**

An ornamental design for a female hose coupling, as shown and described.

**DESCRIPTION**

FIG. 1 is a front perspective view of a female hose coupling; FIG. 2 is a side view of a female hose coupling; FIG. 3 is a front view of a female hose coupling; FIG. 4 is a rear view of a female hose coupling; and, FIG. 5 is a rear perspective view of a female hose coupling. Broken lines are included for the purpose of illustrating portions of the female hose coupling that form no part of the claim.

**1 Claim, 1 Drawing Sheet**

(56) **References Cited**  
U.S. PATENT DOCUMENTS

D130,493 S *	11/1941	Nelson	.....	D23/262
D296,581 S *	7/1988	Hattori	.....	D23/262
5,072,971 A *	12/1991	Roman	.....	F16L 37/252 285/402
D333,511 S *	2/1993	Mikiya	.....	D13/151
D437,919 S *	2/2001	Chao	.....	D23/262
D438,603 S *	3/2001	Chao	.....	D23/262

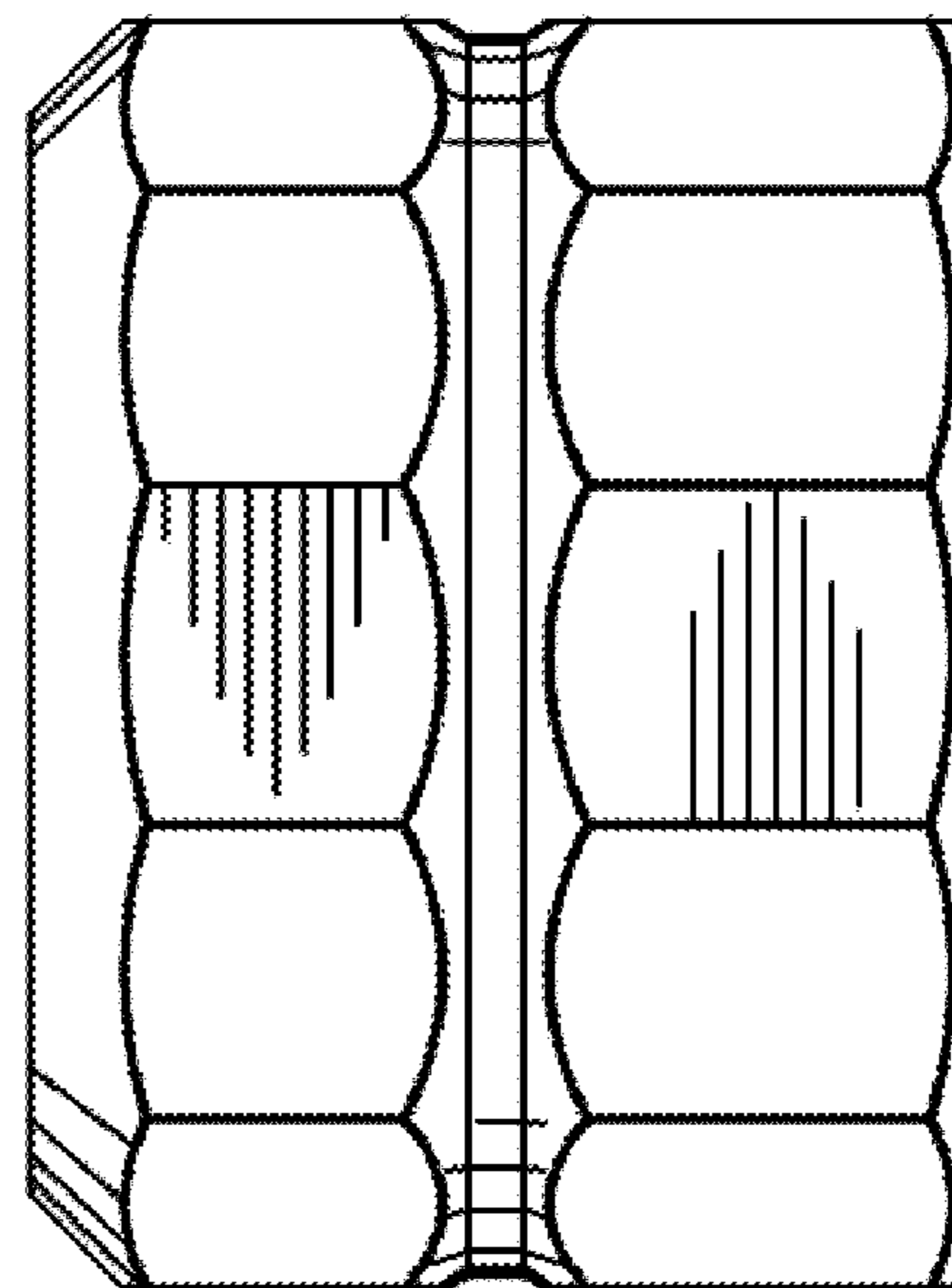
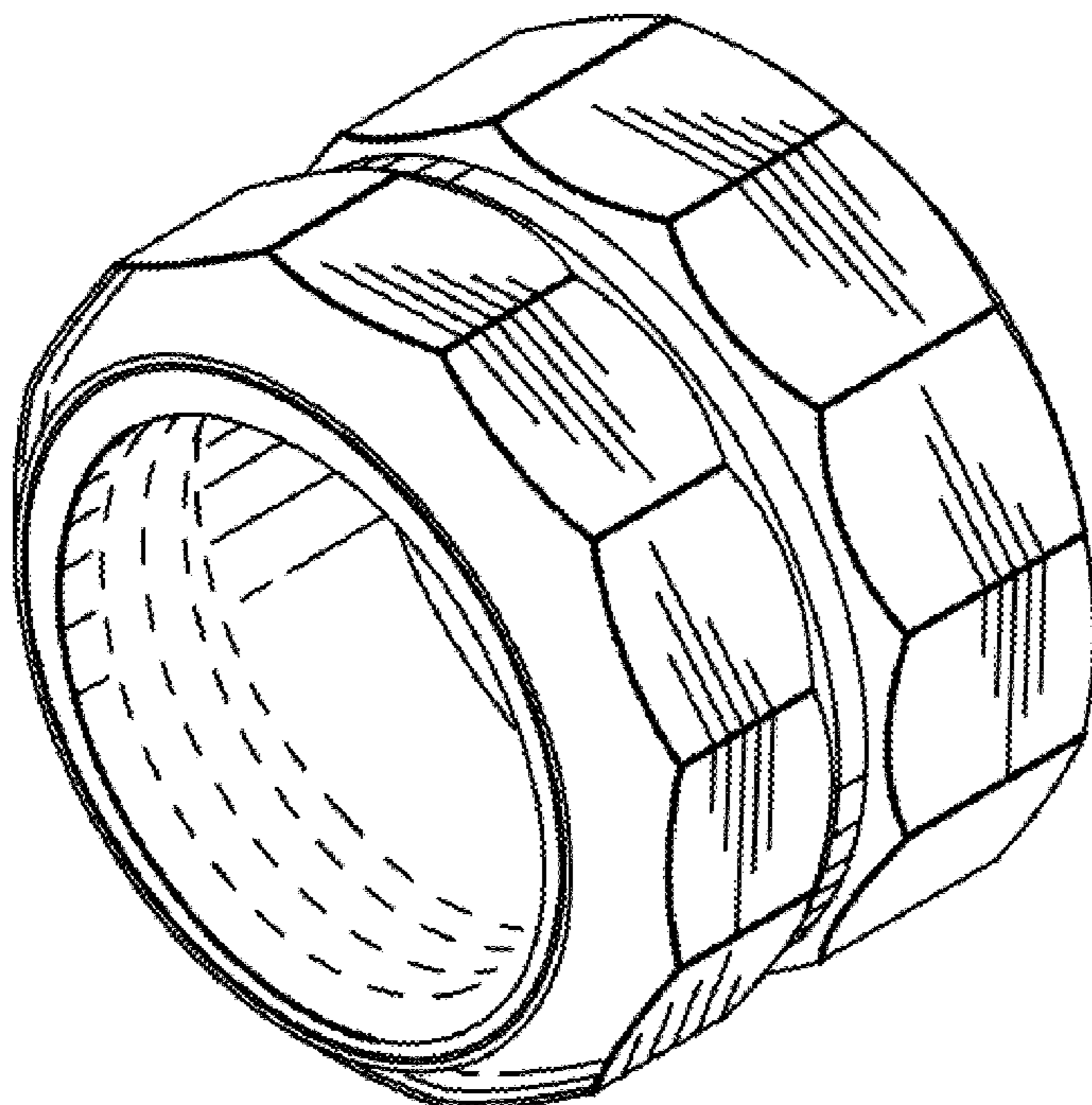

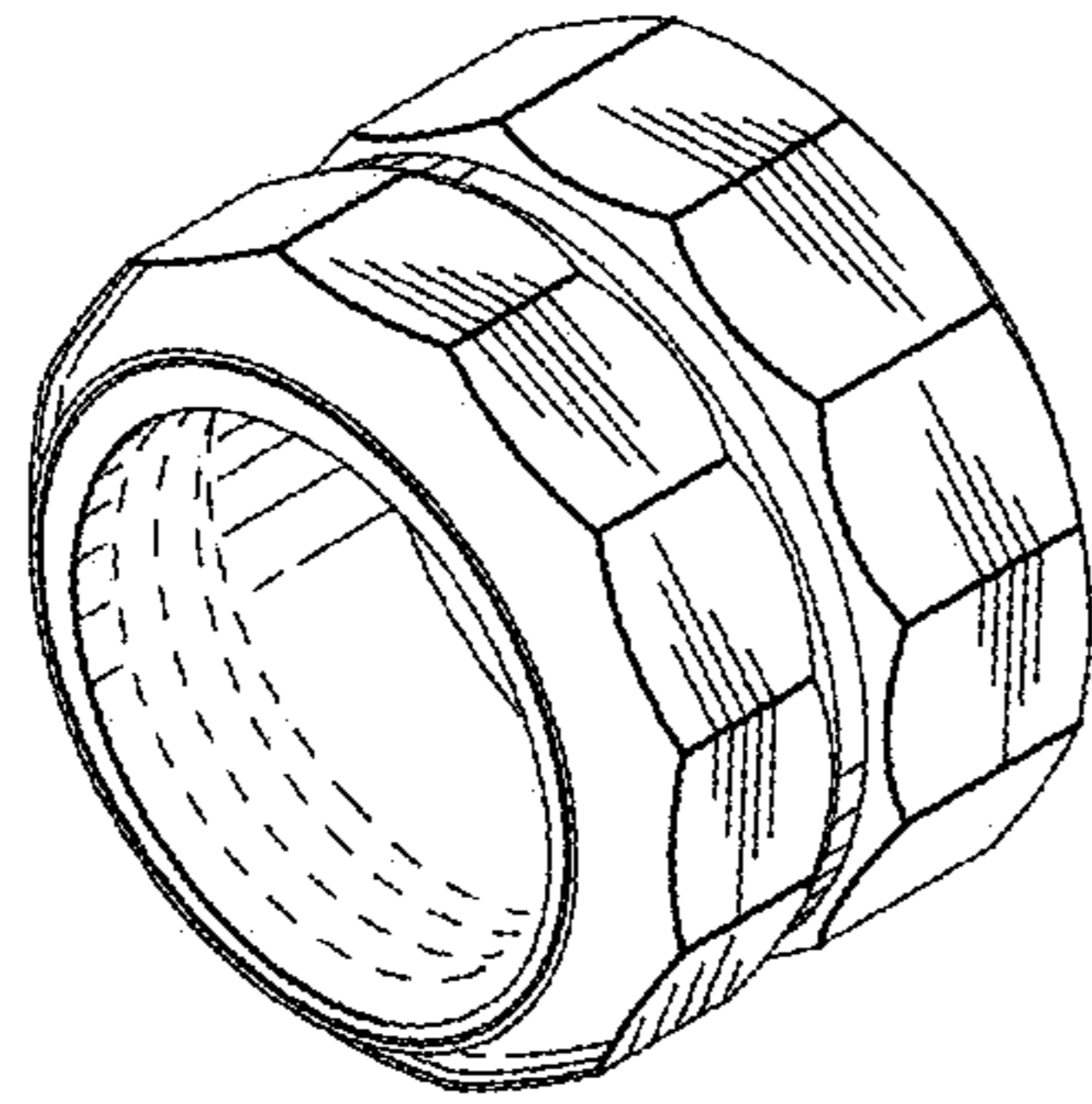

FIG. 1

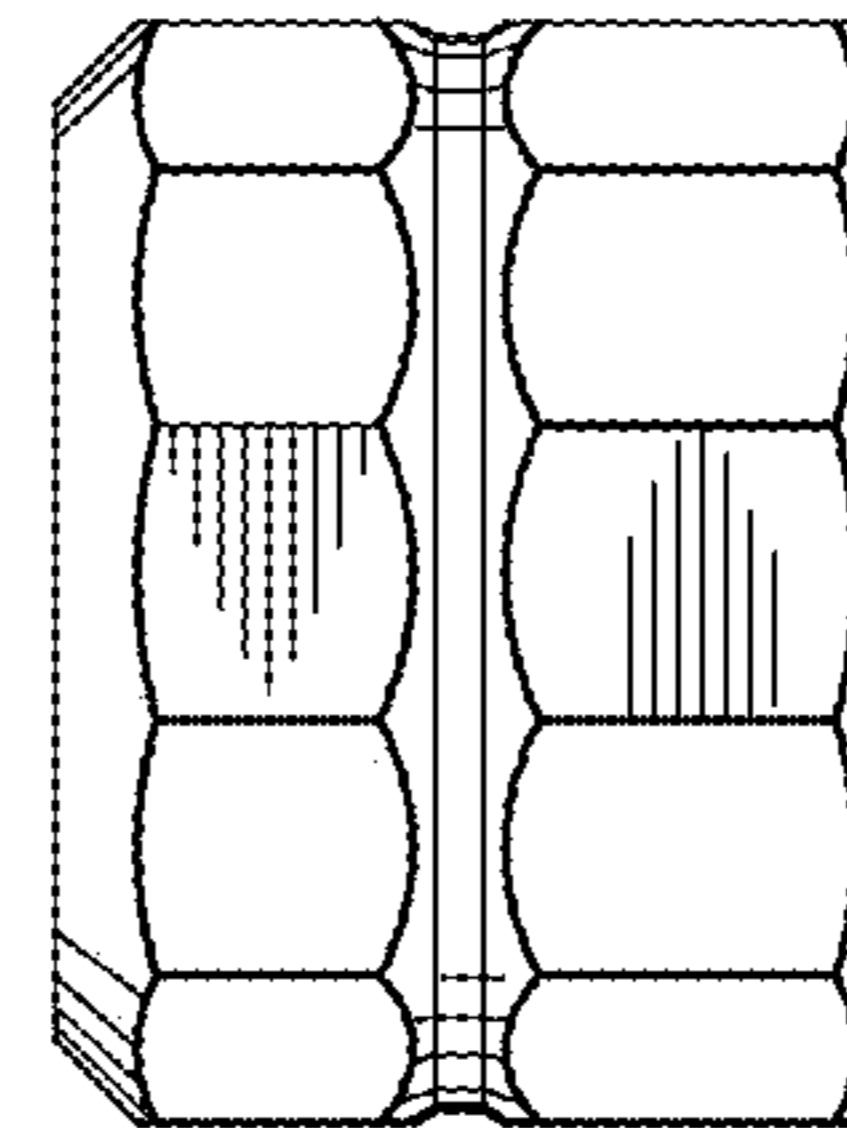

FIG. 2

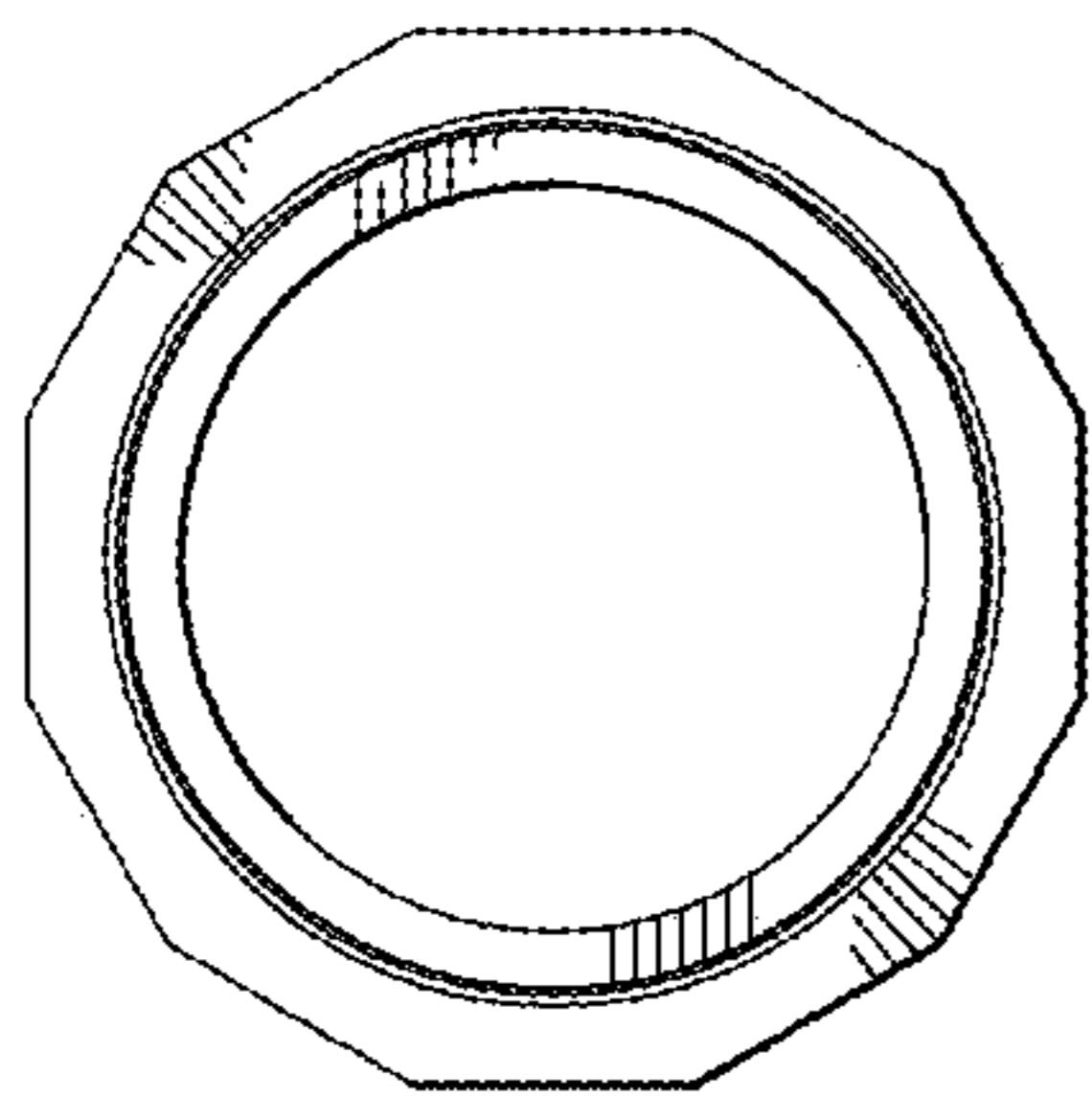

FIG. 3

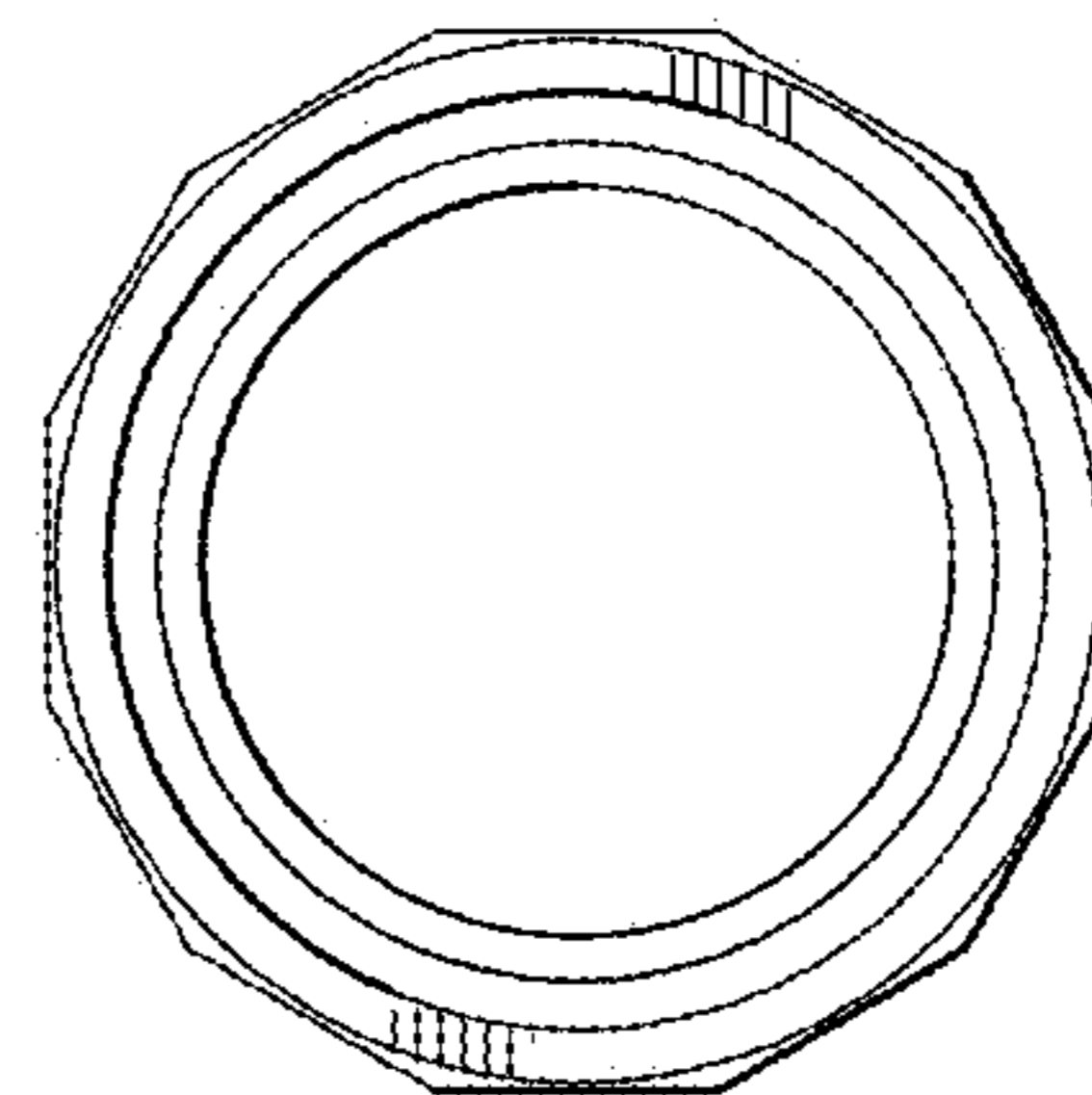

FIG. 4

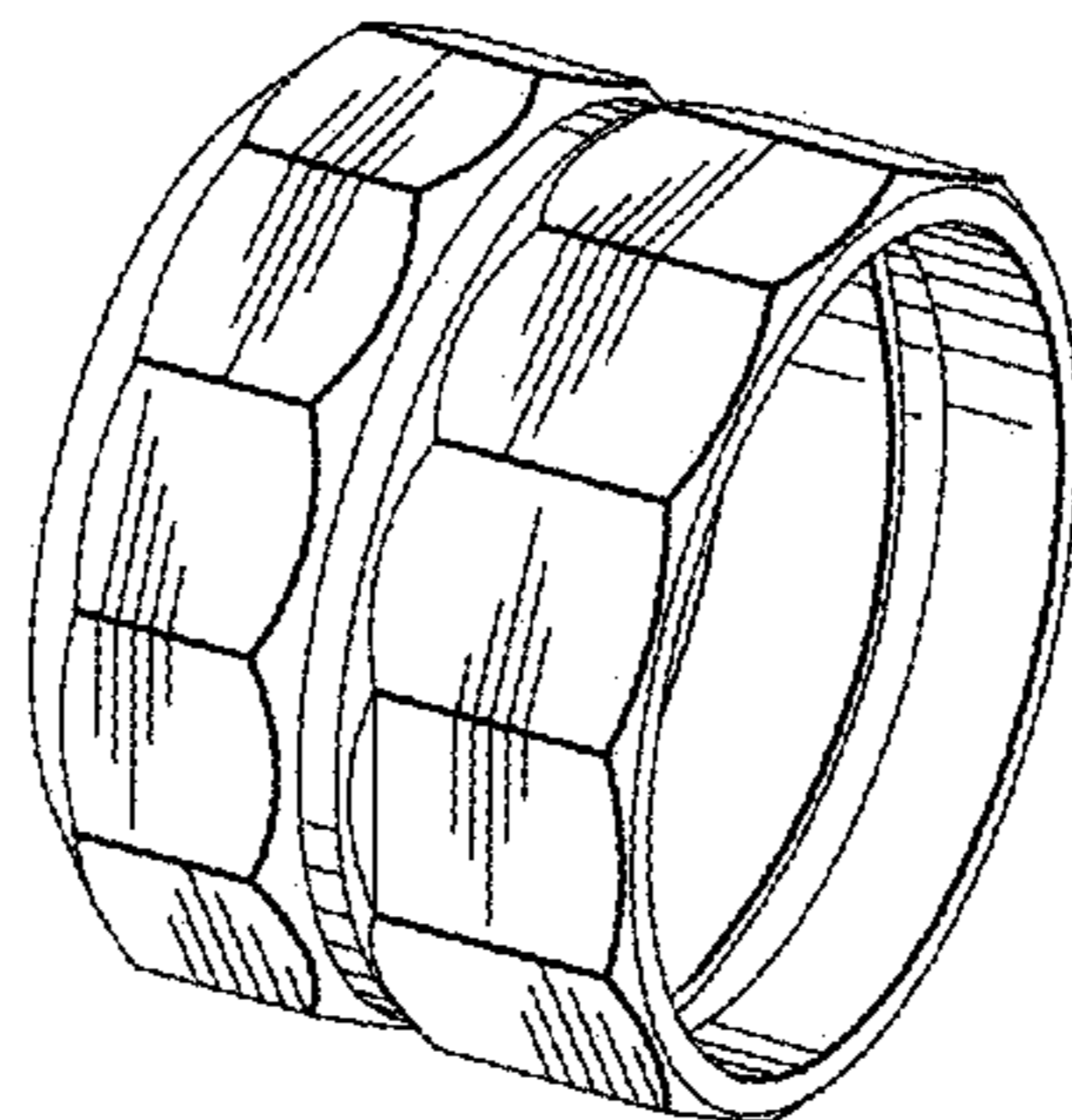

FIG. 5