



US00D876304S

(12) **United States Design Patent** (10) **Patent No.:** **US D876,304 S**
Kito (45) **Date of Patent:** **** Feb. 25, 2020**

(54) **AUTOMOTIVE CHARGING CONNECTOR CAP**

(71) Applicant: **Sumitomo Wiring Systems, Ltd.,**
Yokkaichi-shi (JP)

(72) Inventor: **Yu Kito,** Yokkaichi (JP)

(73) Assignee: **Sumitomo Wiring Systems, Ltd.,**
Yokkaichi-shi (JP)

(**) Term: **15 Years**

(21) Appl. No.: **29/692,265**

(22) Filed: **May 23, 2019**

(30) **Foreign Application Priority Data**

Nov. 28, 2018 (JP) 2018-025845

(51) **LOC (12) Cl.** **12-16**

(52) **U.S. Cl.**
USPC **D12/197**

(58) **Field of Classification Search**
USPC D12/197-201, 110, 114, 218; D23/260;
D15/150; D7/398; D9/443-444,
D9/451-454, 435; D8/301-312
CPC B60H 1/34; B25B 27/0042; B60K 15/05
See application file for complete search history.

(56) **References Cited**

U.S. PATENT DOCUMENTS

D573,928 S * 7/2008 Ratcliffe D12/197
D575,216 S * 8/2008 Shelby D12/197
D575,713 S * 8/2008 Ratcliffe D12/197
D582,327 S * 12/2008 Ratcliffe D12/197
D611,885 S * 3/2010 Dringenberg D12/197

D617,459 S * 6/2010 Bogue D12/197
8,291,608 B2 * 10/2012 Fogle F01M 11/0408
33/728
D756,280 S * 5/2016 Davito D12/197
D775,041 S * 12/2016 Matsumura D12/197
D806,624 S * 1/2018 Lu D12/197
D816,005 S * 4/2018 Johns D12/197
D842,789 S * 3/2019 Chen D12/197
D849,633 S * 5/2019 Capristo D12/197

* cited by examiner

Primary Examiner — Katrina A Betton

(74) *Attorney, Agent, or Firm* — Schwegman Lundberg & Woessner, P.A.

(57) **CLAIM**

The ornamental design for an automotive charging connector cap, as shown and described.

DESCRIPTION

FIG. 1 is a front, top and right side perspective view of an automotive charging connector cap showing my new design; FIG. 2 is a rear, bottom and left side perspective view thereof; FIG. 3 is a front view thereof; FIG. 4 is a rear view thereof; FIG. 5 is a top plan view thereof; FIG. 6 is a bottom plan view thereof; FIG. 7 is a right side view thereof; FIG. 8 is a left side view thereof; and, FIG. 9 is a perspective view thereof with a cap in an open position.

The broken lines illustrate portions of the automotive charging connector cap that form no part of the claimed design. The dash-dotted lines denote the boundary of the claim and form no part of the claimed design.

1 Claim, 9 Drawing Sheets

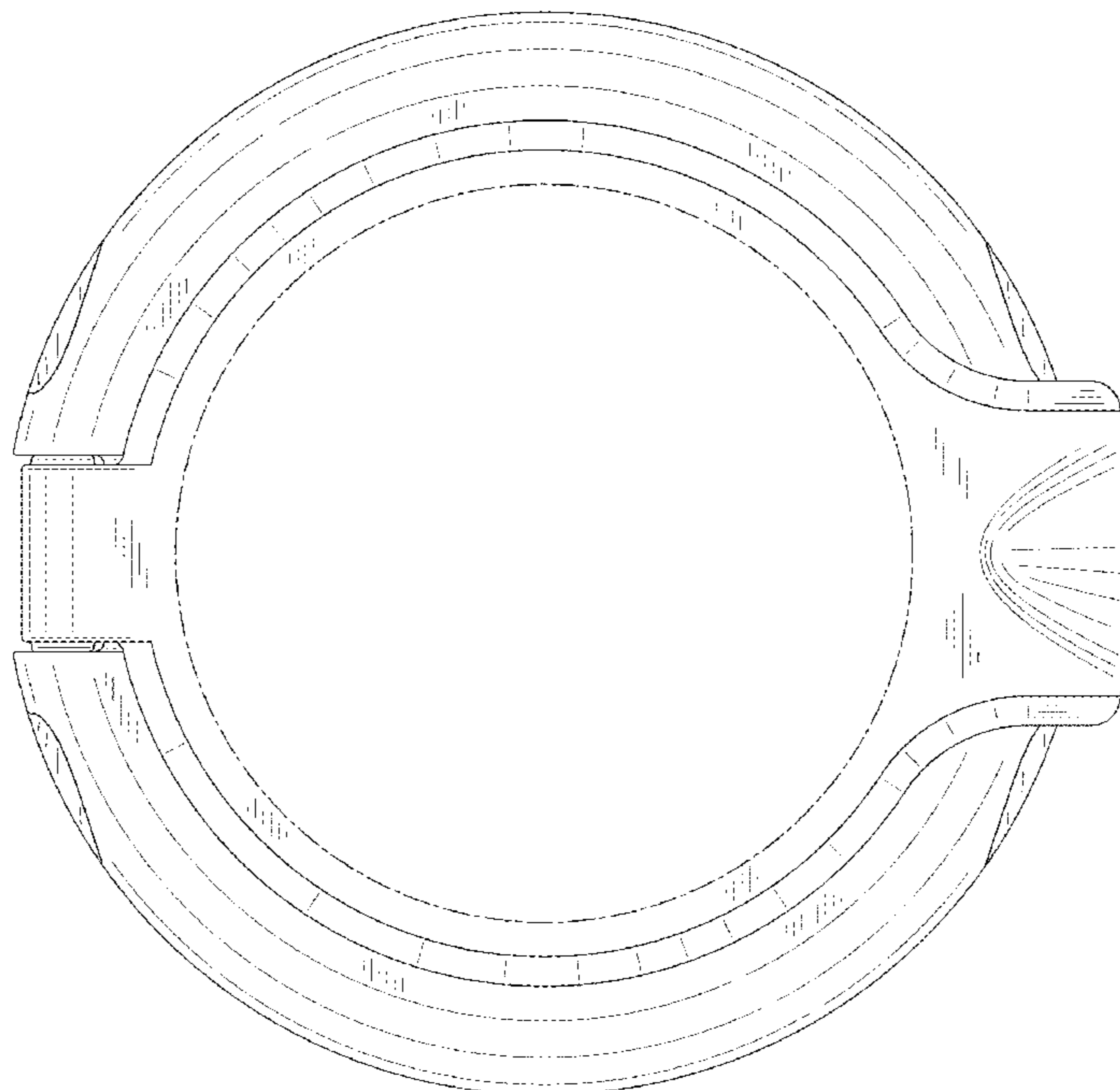

FIG. 1

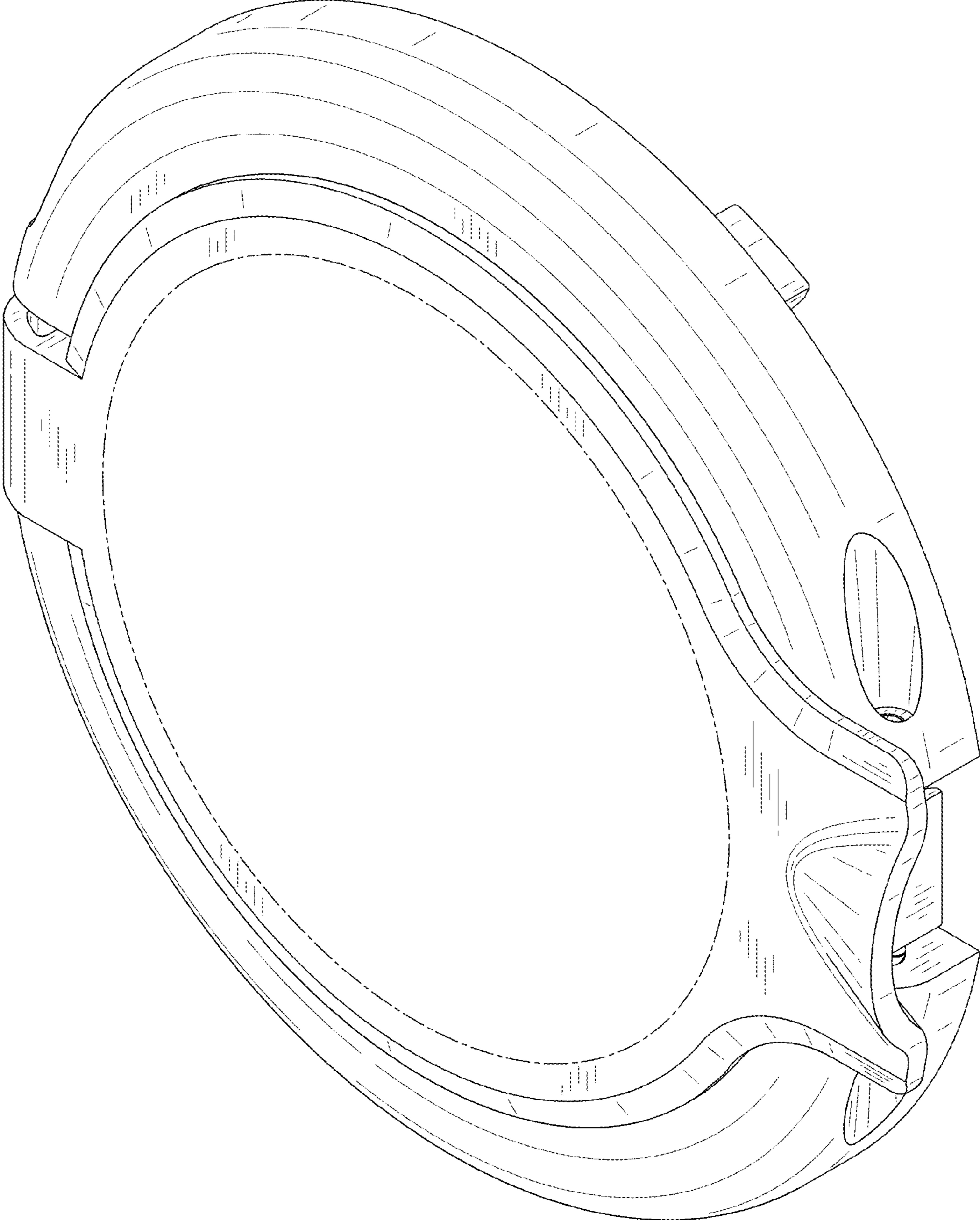

FIG.2

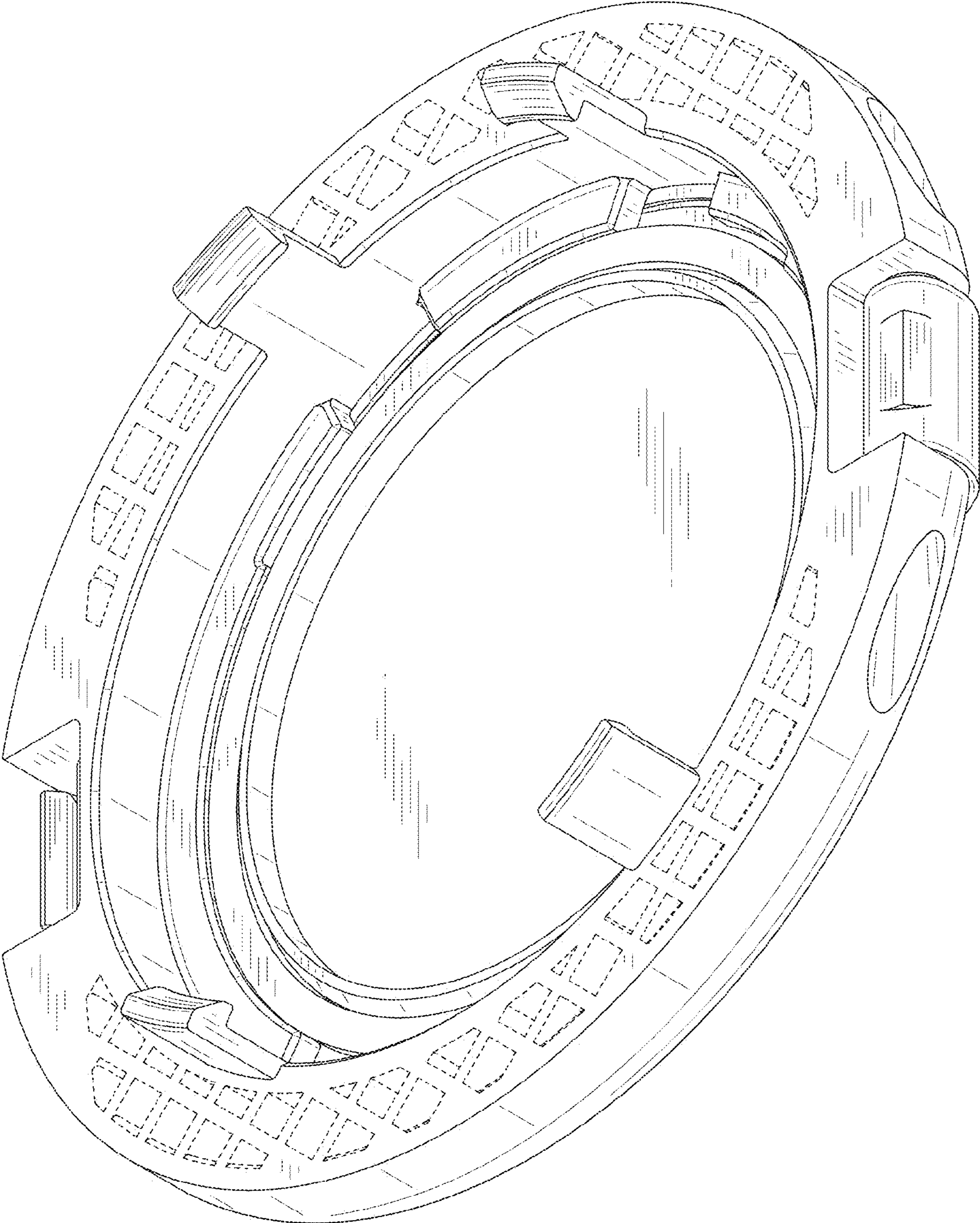

FIG.3

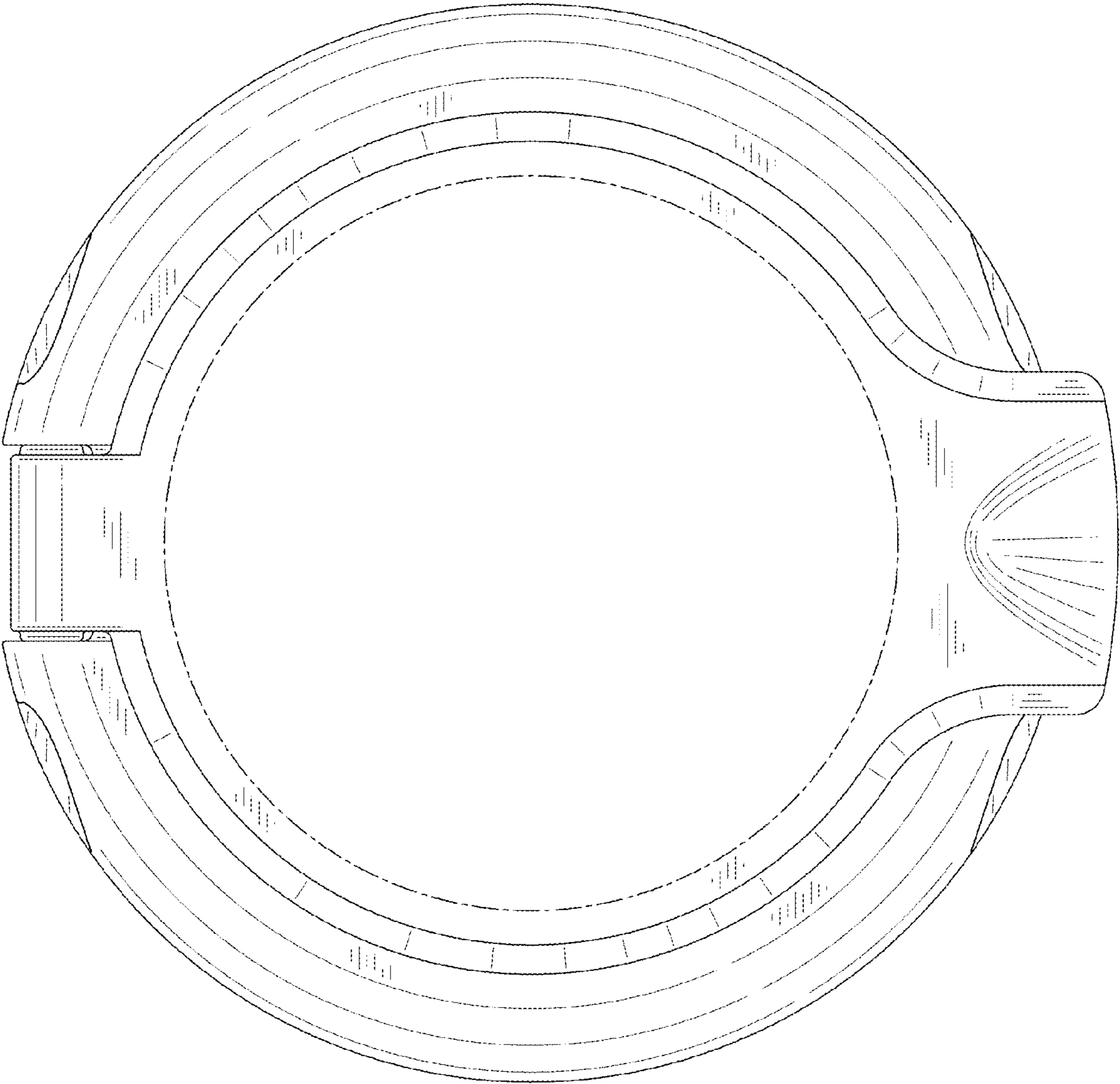

FIG.4

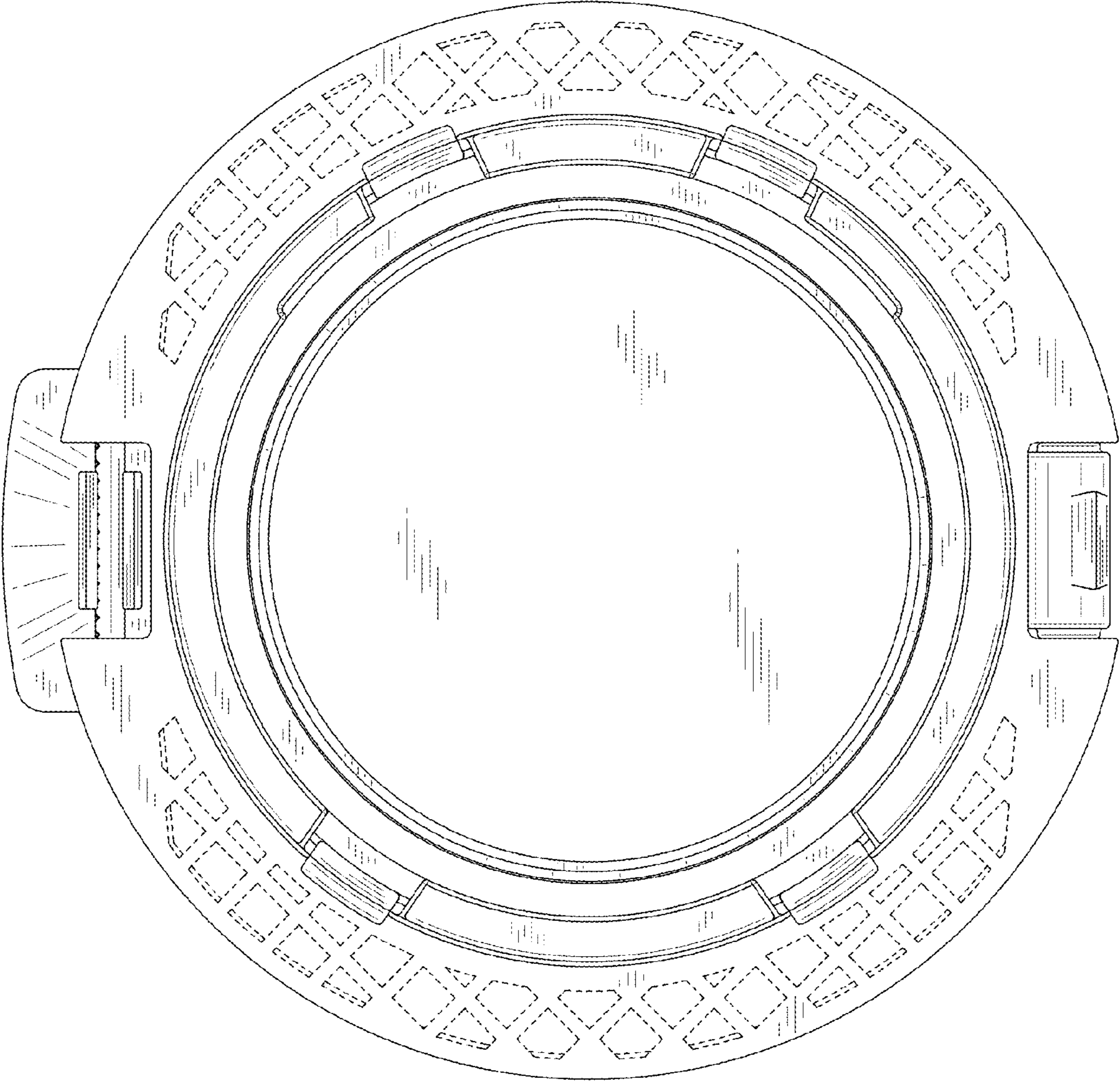

FIG.5

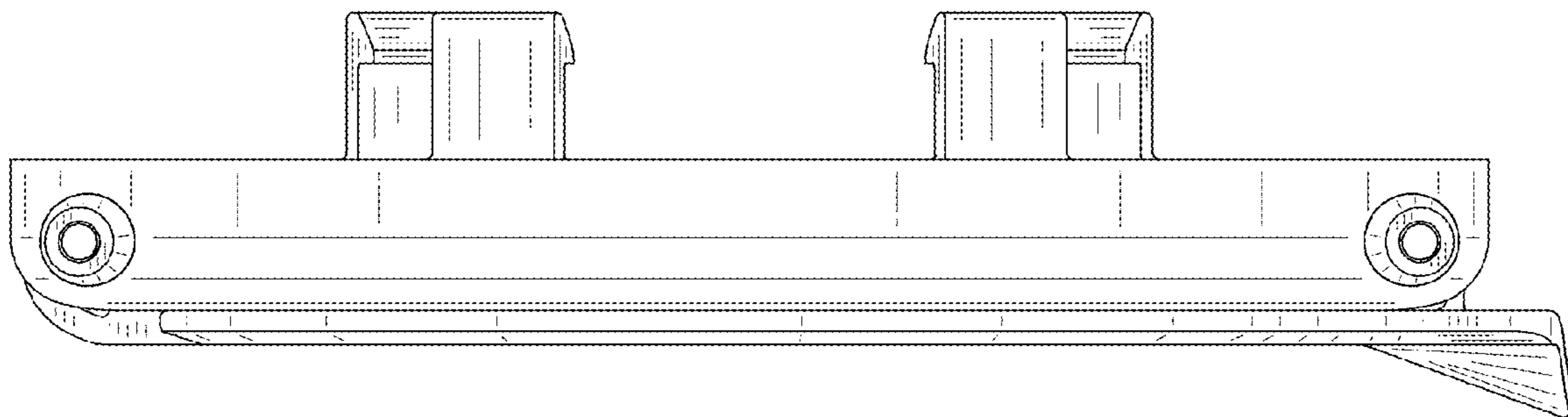

FIG.6

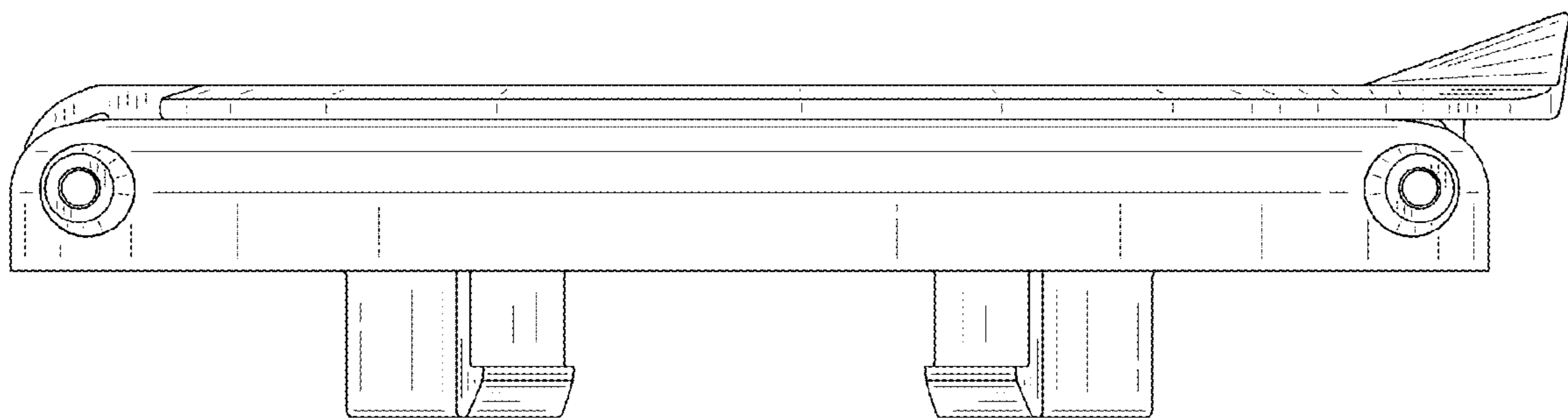

FIG.7

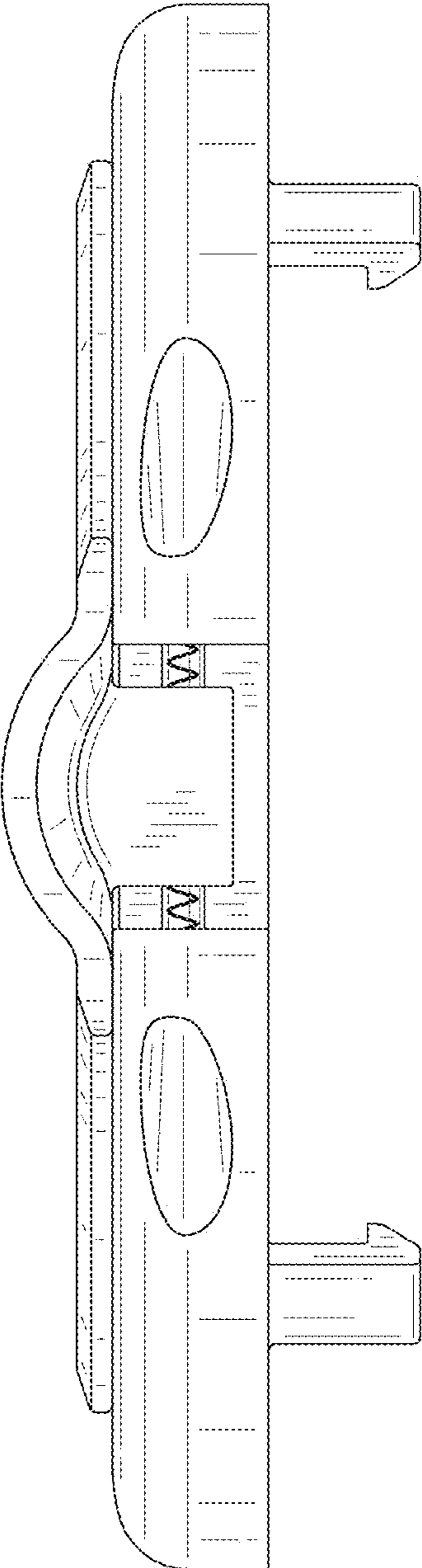
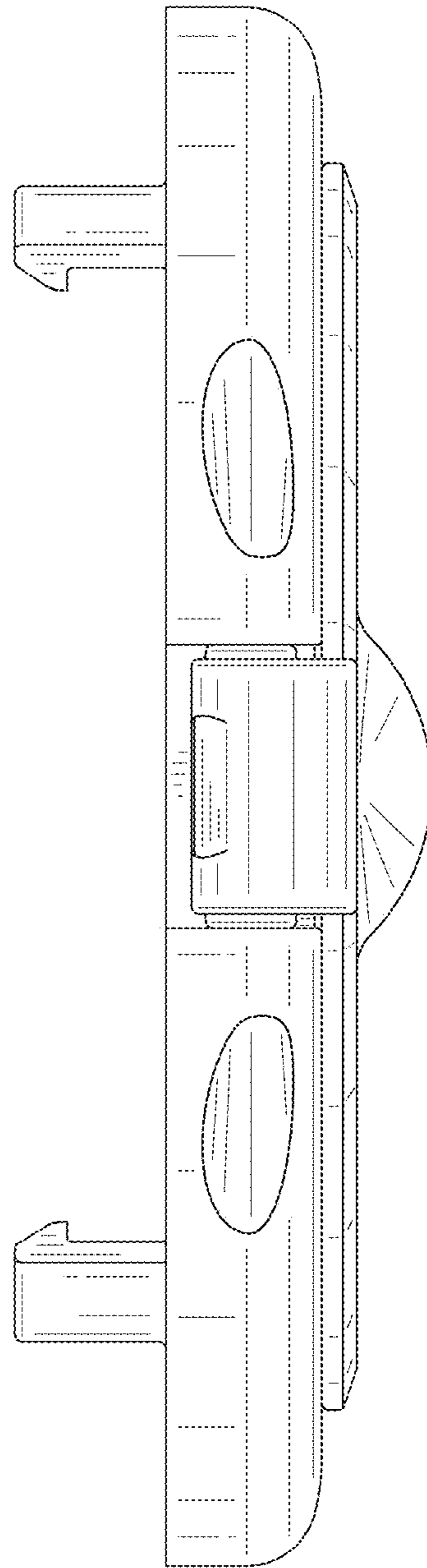

FIG.8



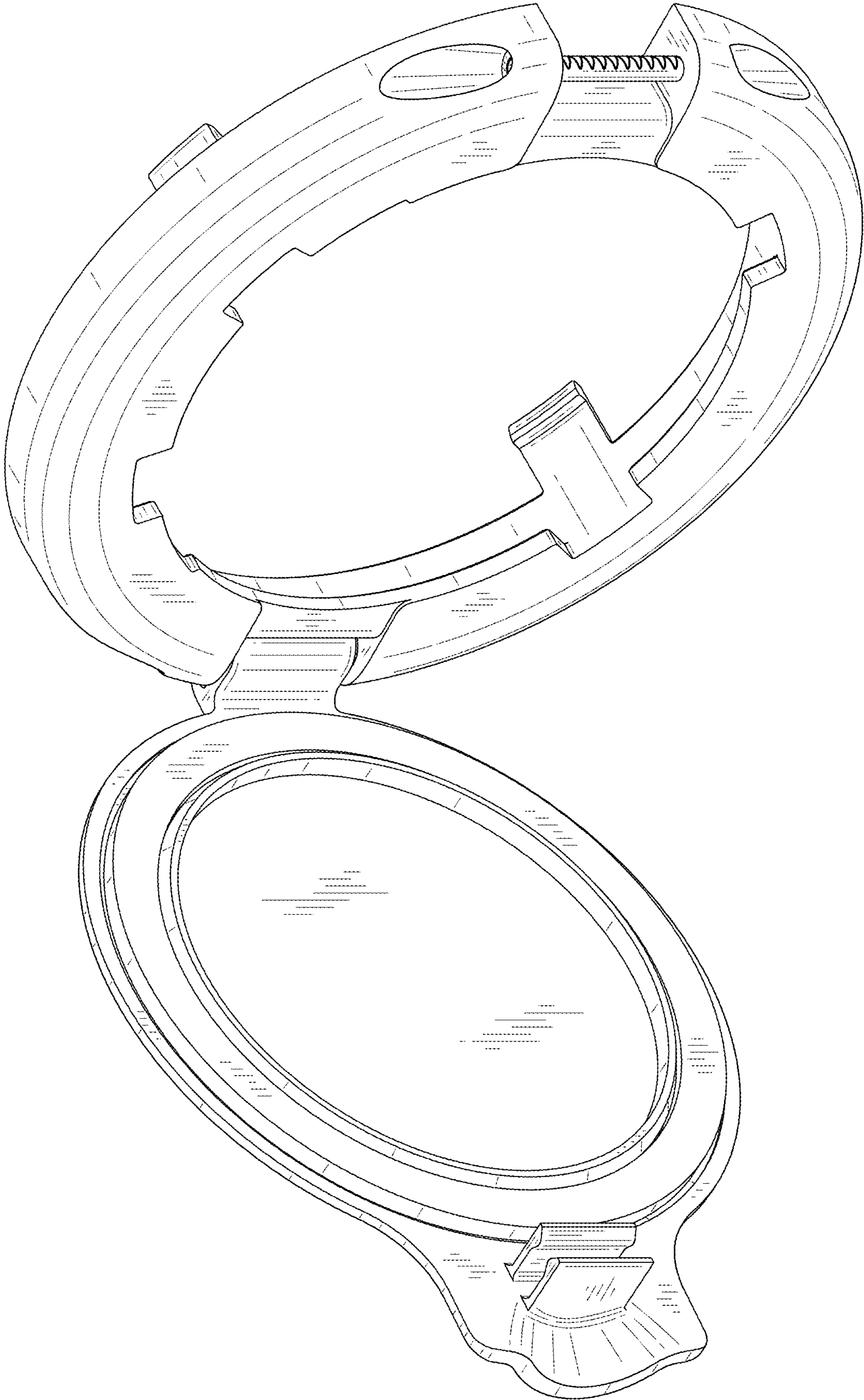

FIG.9