



US00D876301S

(12) **United States Design Patent**
Setina et al.

(10) **Patent No.: US D876,301 S**

(45) **Date of Patent: ** Feb. 25, 2020**

(54) **PANEL CONSTRUCTION FOR VEHICLE PARTITION**

(71) Applicant: **J.R. Setina Manufacturing Co., Inc.**,
Olympia, WA (US)

(72) Inventors: **Terry L. Setina**, Olympia, WA (US);
Adam Sampson, Tenino, WA (US)

(73) Assignee: **J.R. Setina Manufacturing Co., Inc.**,
Olympia, WA (US)

(**) Term: **15 Years**

(21) Appl. No.: **29/610,463**

(22) Filed: **Jul. 12, 2017**

(51) **LOC (12) Cl.** **12-08**

(52) **U.S. Cl.**
USPC **D12/190**

(58) **Field of Classification Search**
USPC D12/192, 181, 415, 195, 317, 196, 400,
D12/404; 114/201 R, 203; 49/381;
296/37.6, 37.8, 37.15
CPC B64C 1/14; B64C 1/446; B60H 1/262;
B63B 3/54; B60R 2011/0019; B60R
2013/018

See application file for complete search history.

(56) **References Cited**

U.S. PATENT DOCUMENTS

D289,152 S * 4/1987 Fritz D12/190
D386,458 S * 11/1997 Smith D12/167
D644,584 S * 9/2011 Vardis D12/190

* cited by examiner

Primary Examiner — Abraham Bahta
(74) *Attorney, Agent, or Firm* — Klarquist Sparkman,
LLP

(57) **CLAIM**

We claim the ornamental design for a panel construction for vehicle partition, as shown and described.

DESCRIPTION

FIG. 1 is a rear perspective view of the panel construction for vehicle partition showing my new design.

FIG. 2 is a rear elevational view thereof.

FIG. 3 is a front elevational view thereof.

FIG. 4 is a top plan view thereof.

FIG. 5 is a bottom plan view thereof.

FIG. 6 is right side elevational view thereof.

FIG. 7 is a left side elevational view thereof.

FIG. 8 is a section view in elevation taken along the line 8-8 of FIG. 3 and showing a section thereof.

FIG. 9 is a perspective view of the panel construction for vehicle partition of FIG. 1 shown in isolation for clarity of illustration.

FIG. 10 is a top plan view thereof.

FIG. 11 is a bottom plan view thereof.

FIG. 12 is a front elevational view thereof.

FIG. 13 is a left side elevational view thereof; and,

FIG. 14 is a right side elevational view thereof.

The broken line showings of the foot well, window frame, roll bar, center portion, right side panel and mounting brackets illustrate portions of the panel construction for vehicle partition that form no part of the claimed design.

1 Claim, 7 Drawing Sheets

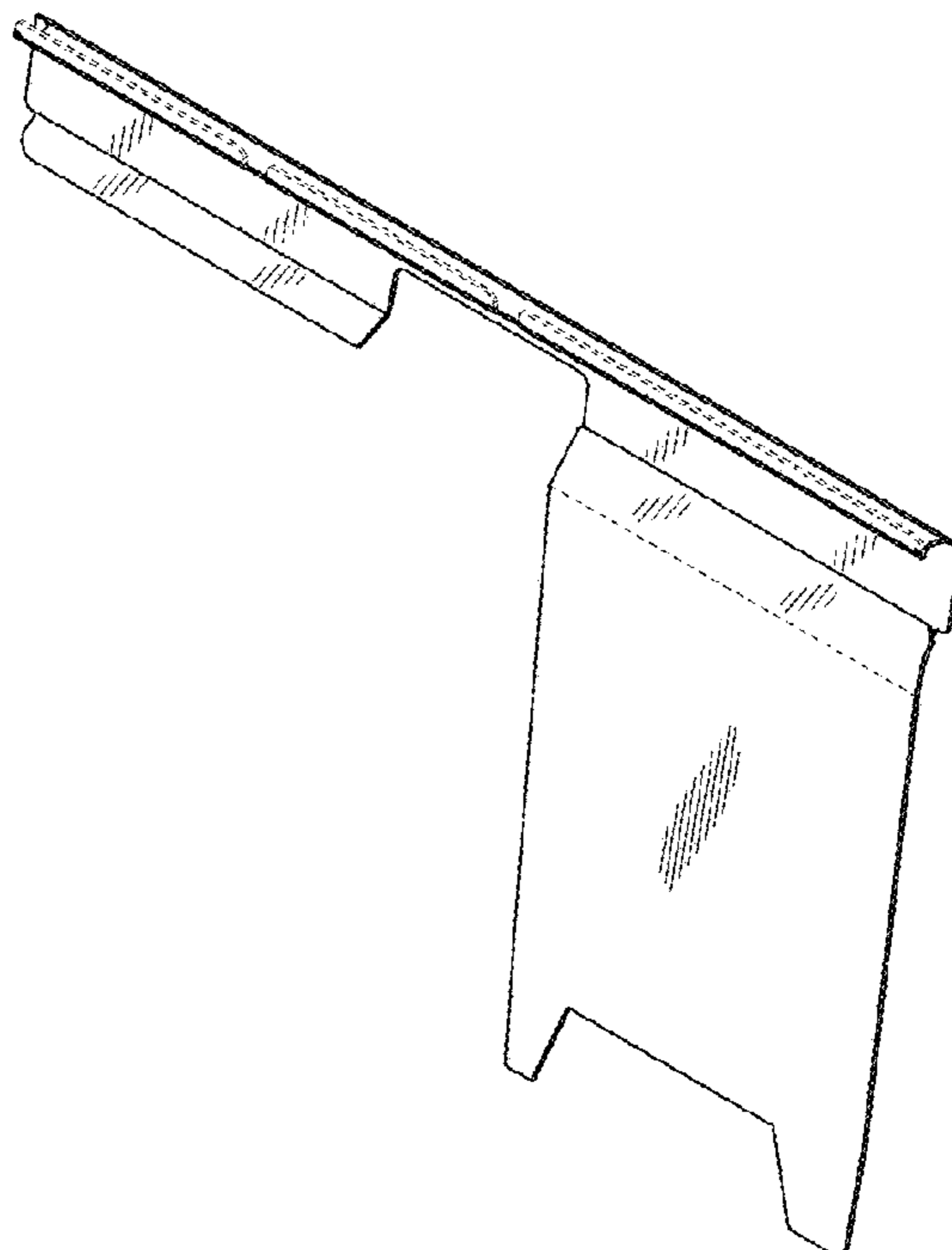
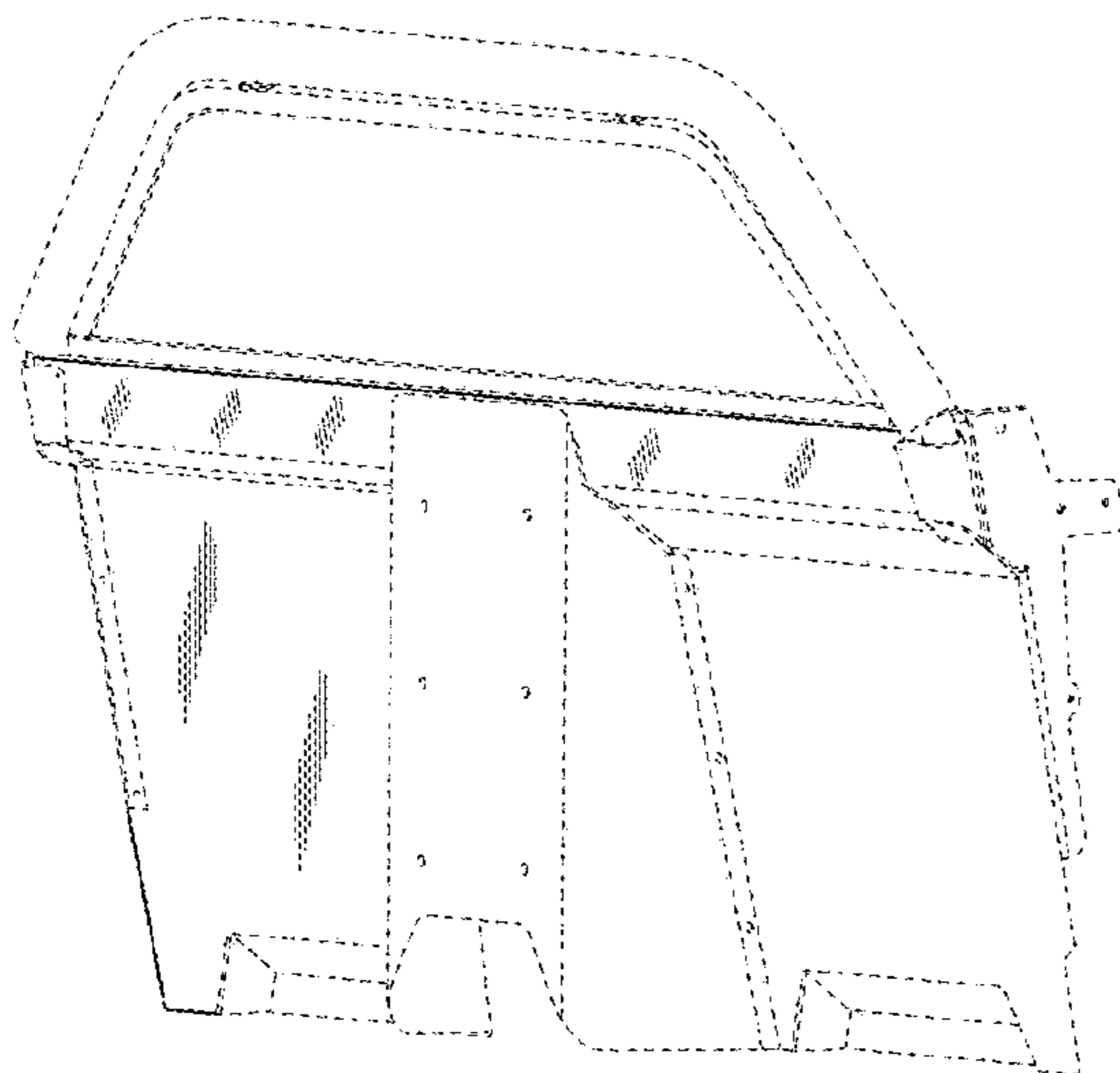

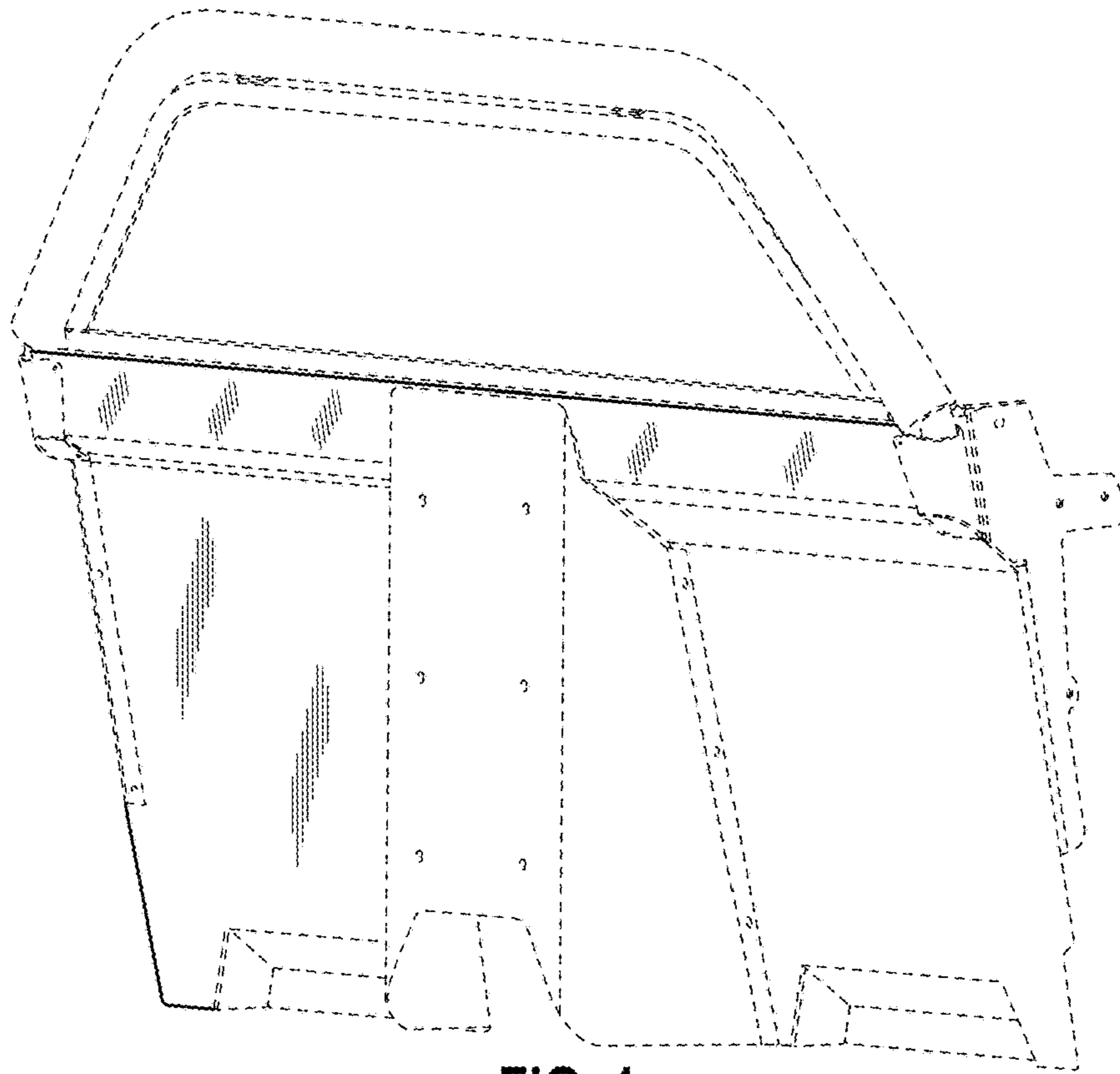

FIG. 1

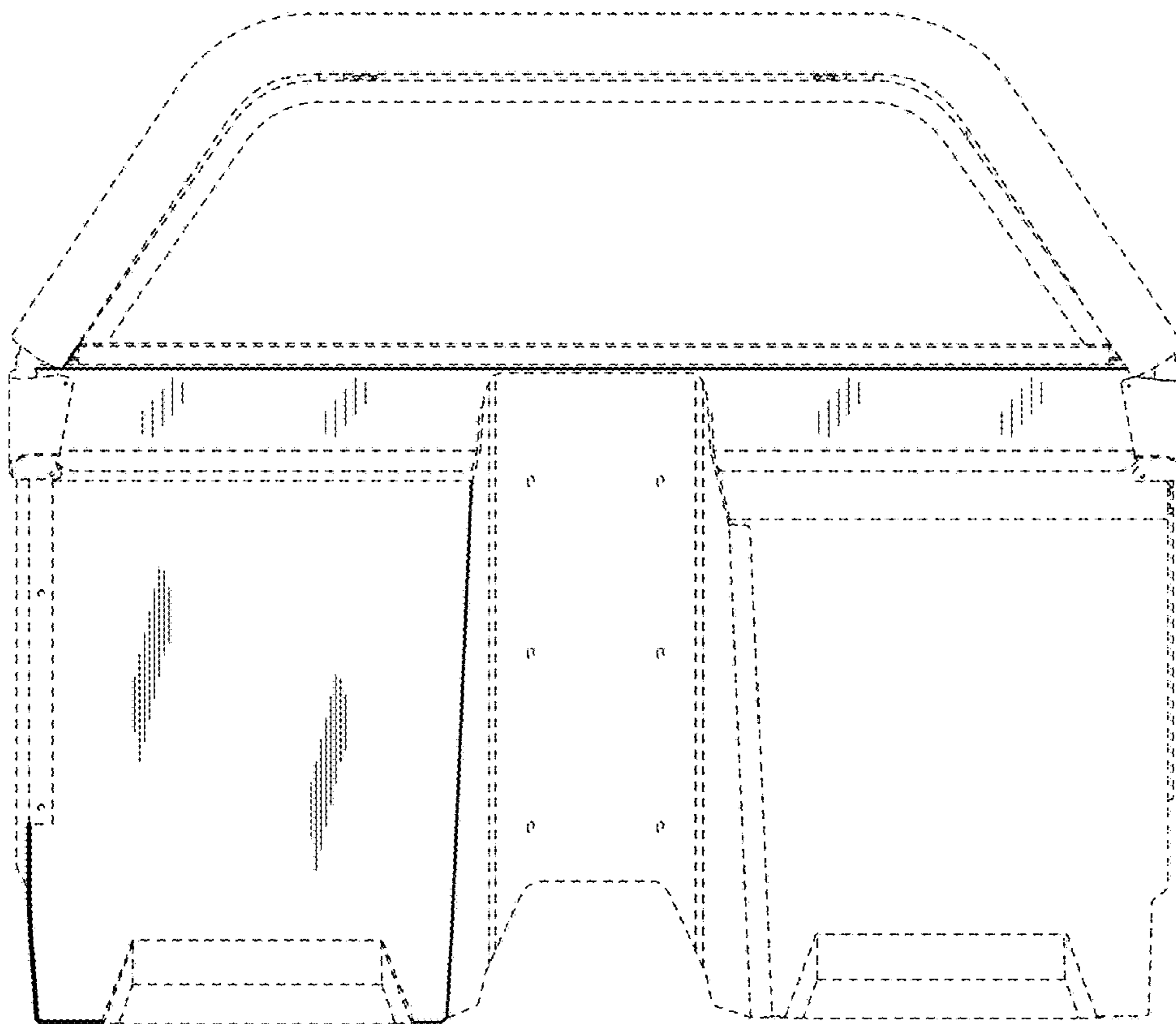

FIG. 2

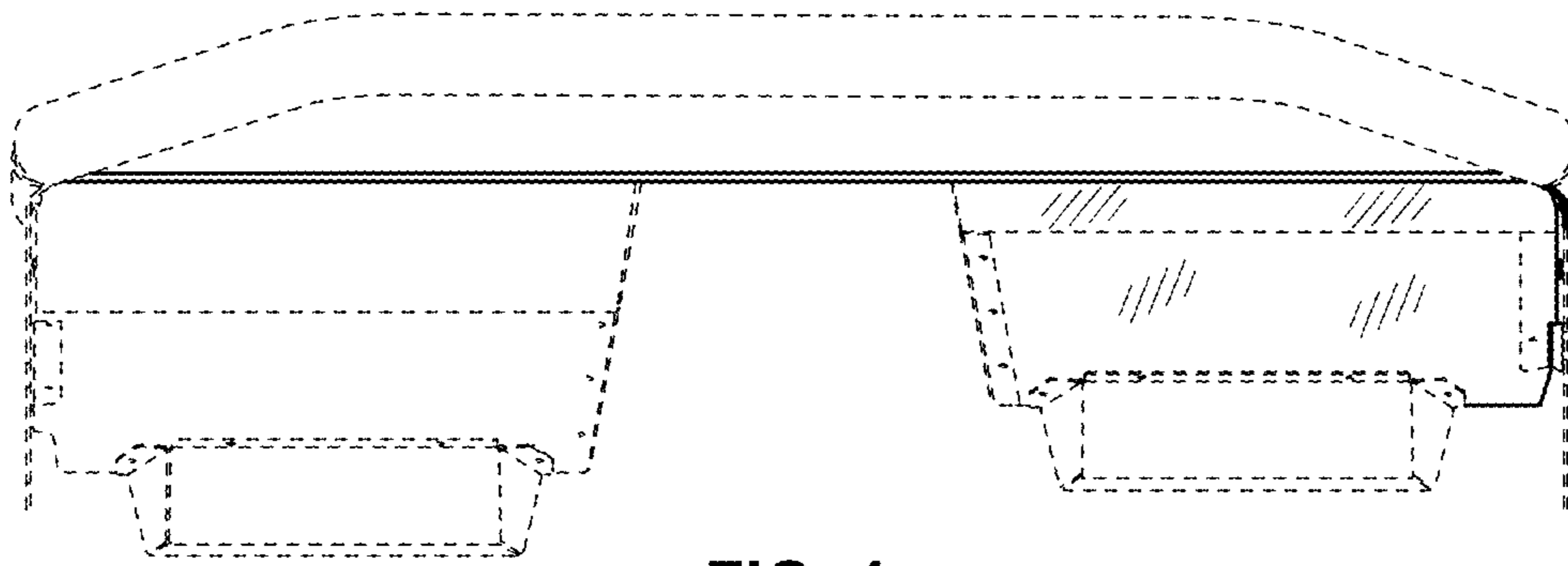

FIG. 4

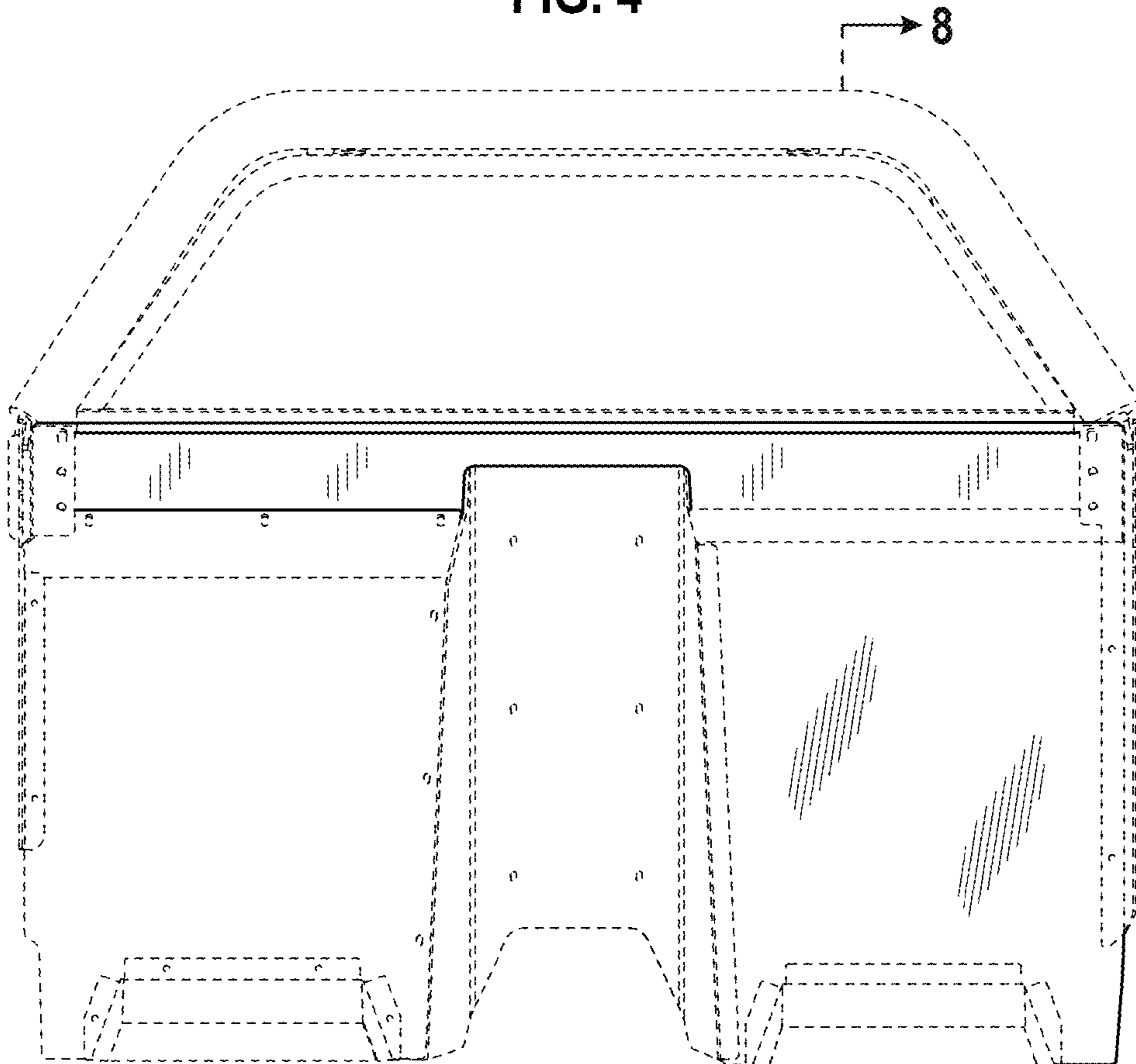

FIG. 3

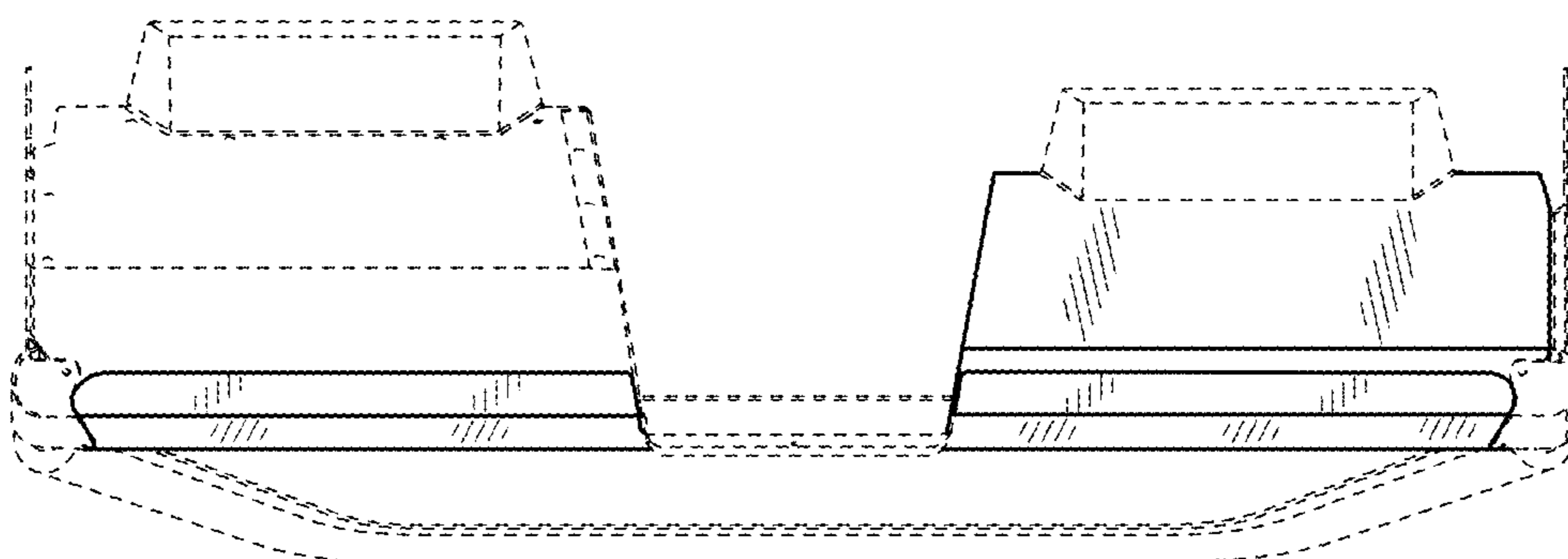

FIG. 5

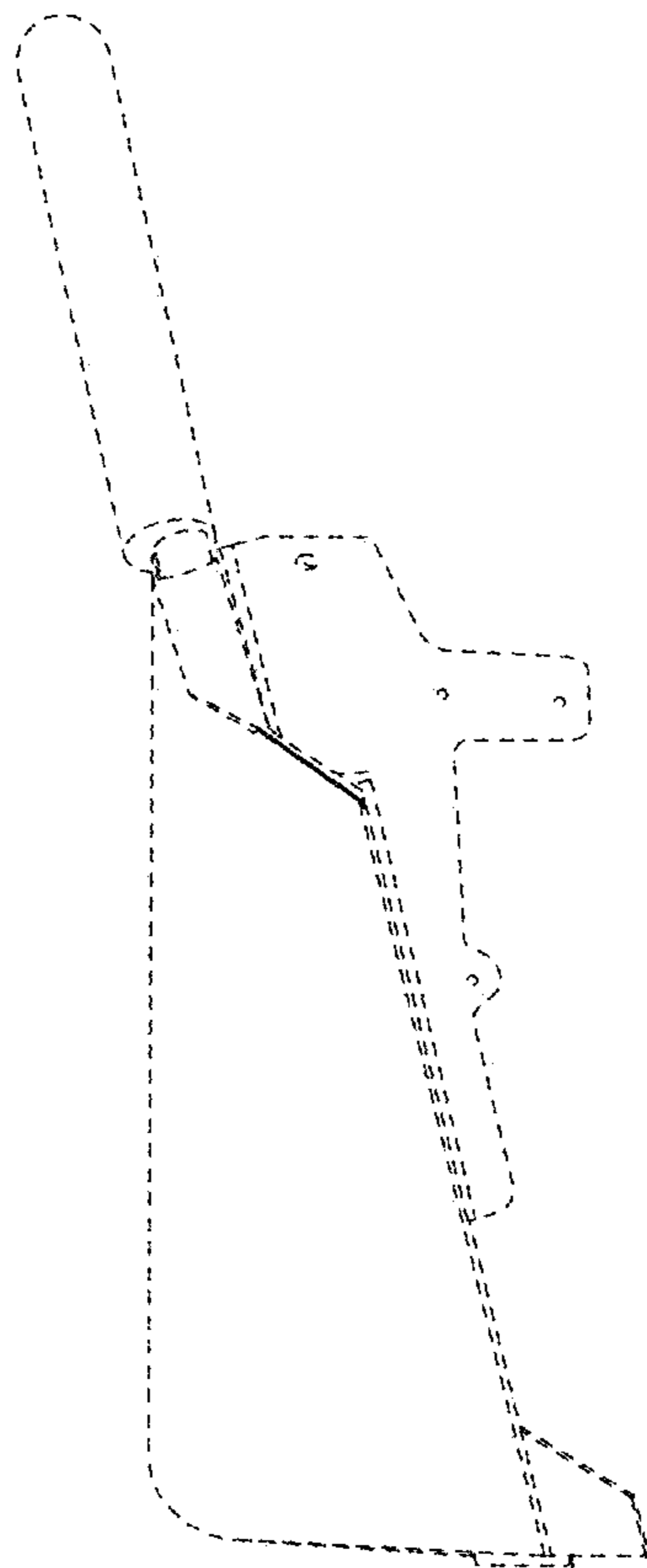

FIG. 6

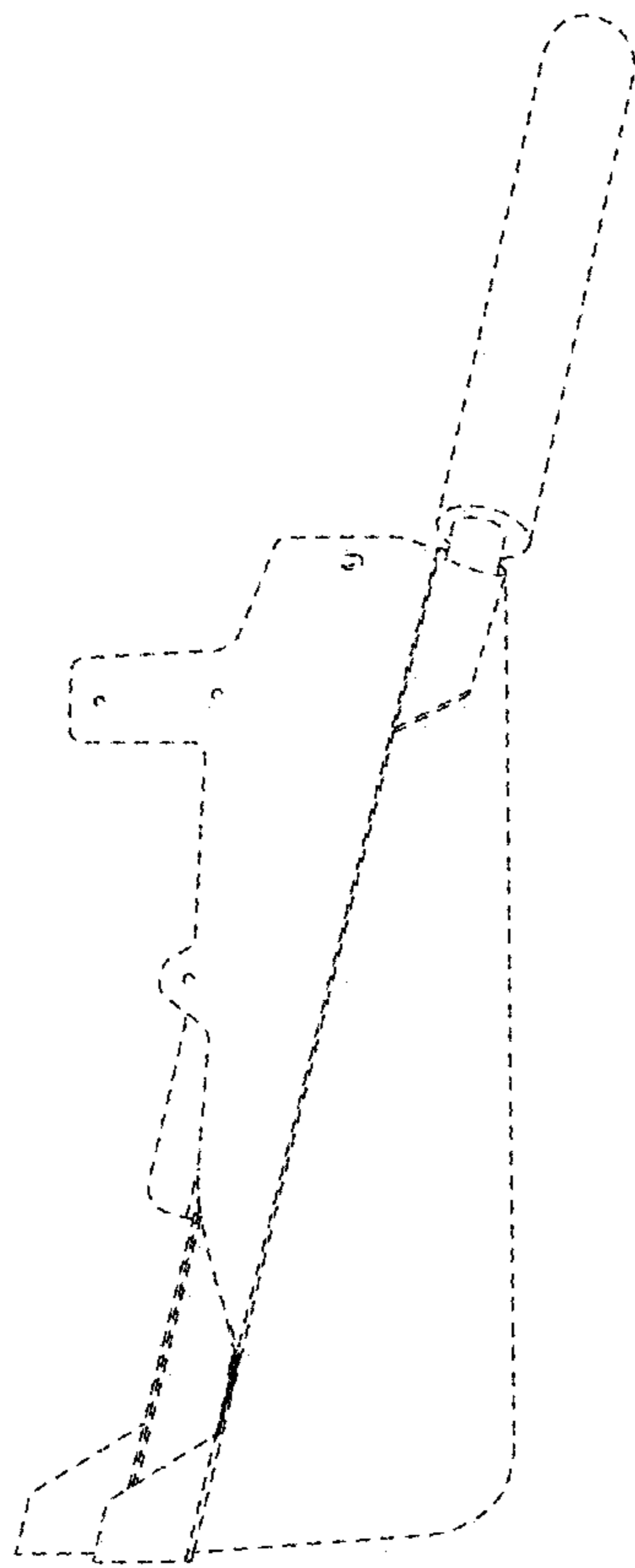

FIG. 7

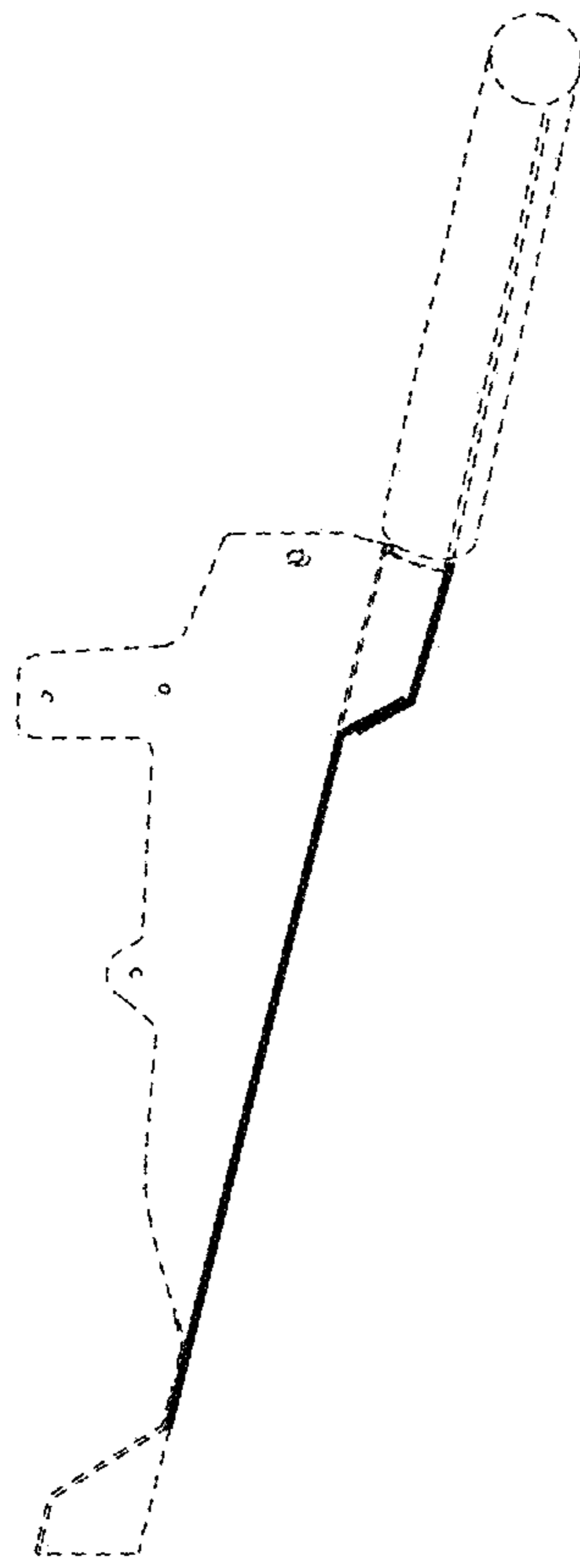

FIG. 8

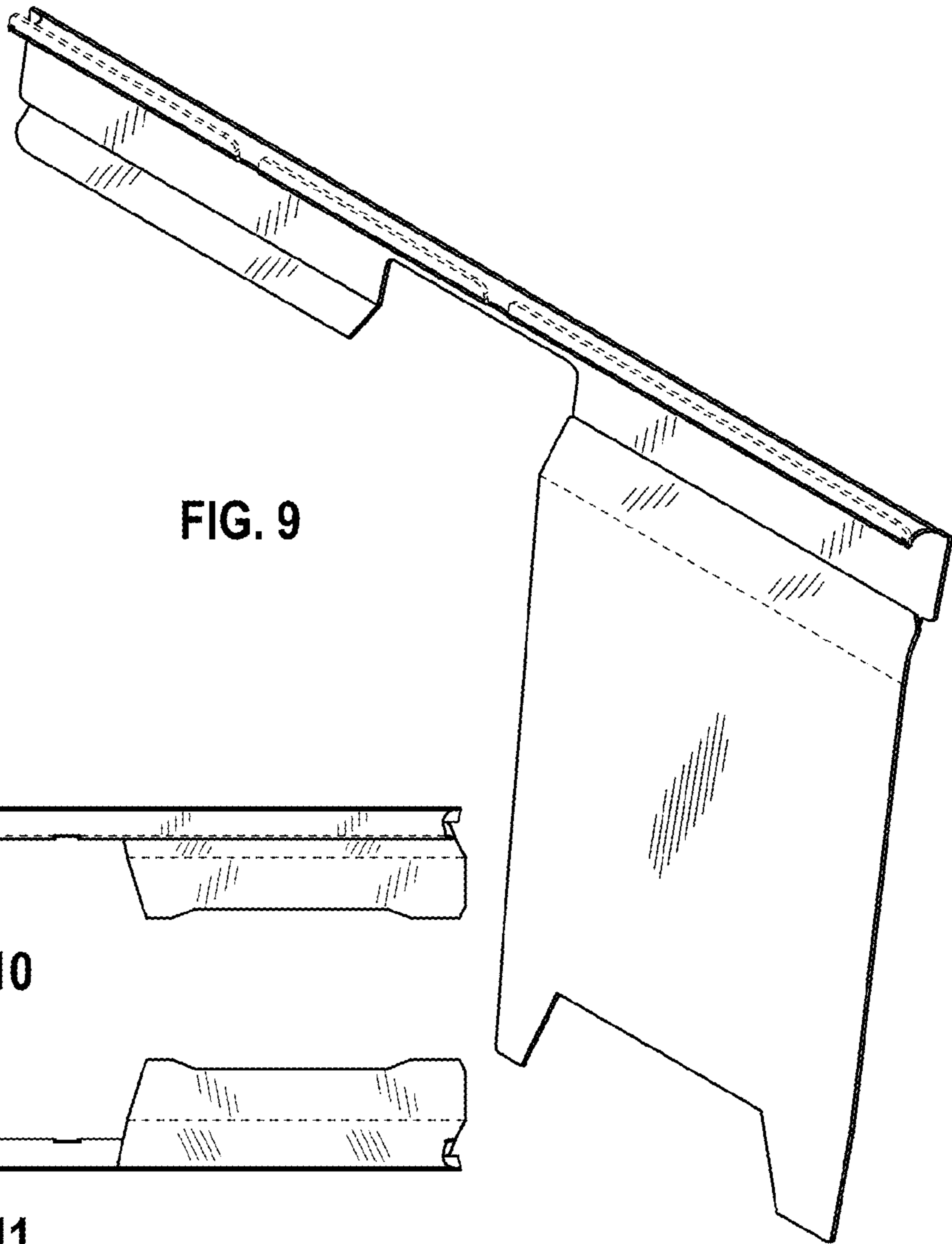

FIG. 9

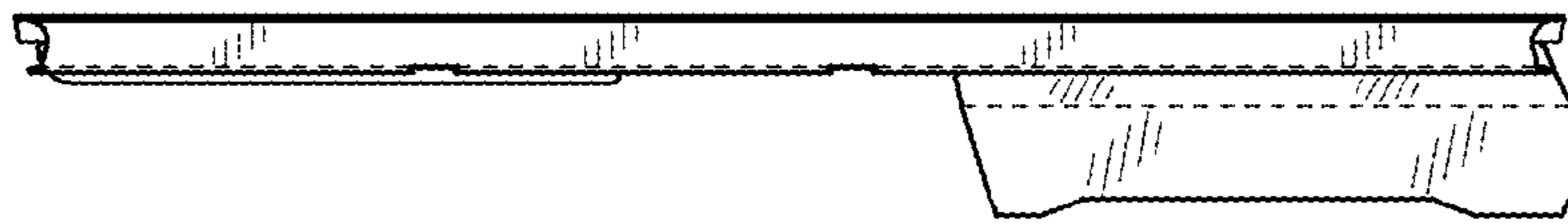

FIG. 10

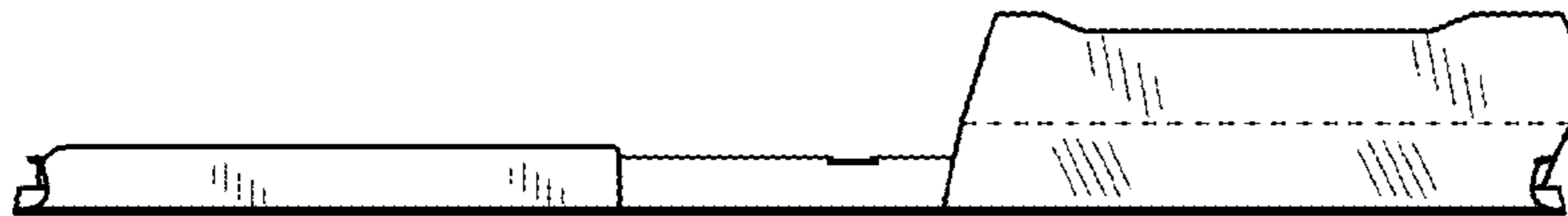

FIG. 11

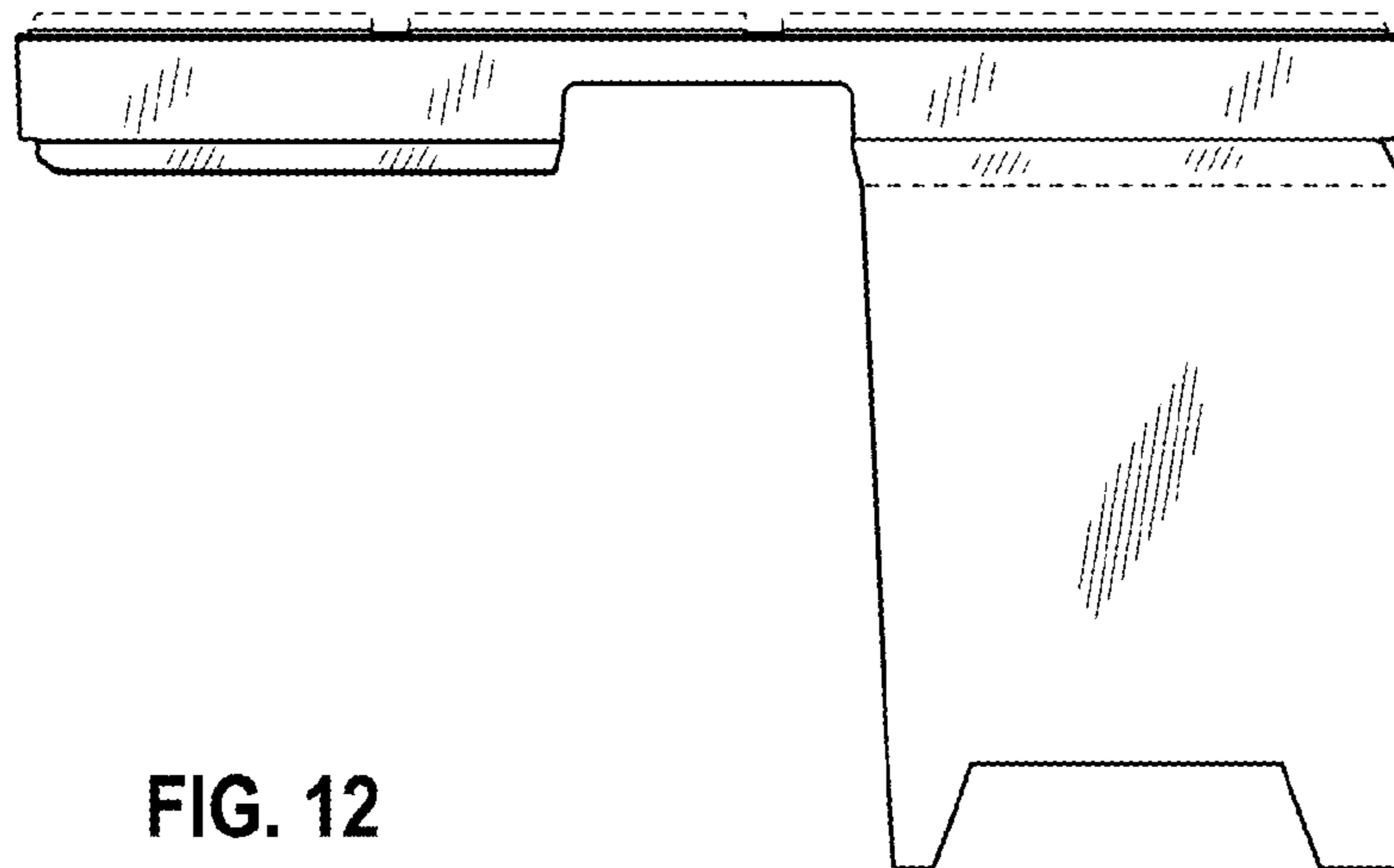

FIG. 12



FIG. 13



FIG. 14