



US00D876285S

(12) **United States Design Patent** (10) **Patent No.:** **US D876,285 S**
Watanabe et al. (45) **Date of Patent:** **** Feb. 25, 2020**

(54) **MOTORCYCLE AND/OR REPLICA THEREOF**

FOREIGN PATENT DOCUMENTS

(71) Applicant: **HONDA MOTOR CO., LTD.**, Tokyo (JP)

CN 304219249 S 7/2017
JP 1293811 S 2/2007
(Continued)

(72) Inventors: **Kazuki Watanabe**, Wako (JP); **Takashi Watanabe**, Wako (JP)

OTHER PUBLICATIONS

(73) Assignee: **HONDA MOTOR CO., LTD.**, Tokyo (JP)

Joseph Gustafson. "The 2019 CB650R Continues Honda's . . ." Cycle World., Nov. 6, 2018 [online], [retrieved on Oct. 22, 2019]. Retrieved from the Internet <URL: <https://www.cycleworld.com/2019-cb650r-continues-hondas-neo-retro-lineup/><https://www.cycleworld.com/2019-cb650r-continues-hondas-neo-retro-lineup/>>.*

(**) Term: **15 Years**

(Continued)

(21) Appl. No.: **29/671,758**

(22) Filed: **Nov. 29, 2018**

Primary Examiner — Darlington Ly

(30) **Foreign Application Priority Data**

(74) *Attorney, Agent, or Firm* — Birch, Stewart, Kolasch & Birch, LLP

May 30, 2018 (JP) 2018-011845

(51) **LOC (12) Cl.** **12-11**

(57) **CLAIM**

(52) **U.S. Cl.**

The ornamental design for a motorcycle and/or replica thereof, as shown and described.

USPC **D12/110**

(58) **Field of Classification Search**

USPC D12/110, 111, 117; D21/432, 538

CPC B62K 11/00; B62K 11/02; B62K 11/04;

B62K 11/10; B62K 17/00; B62K 19/00;

B62K 2202/00

See application file for complete search history.

DESCRIPTION

(56) **References Cited**

FIG. 1 is a front elevation view of a motorcycle and/or replica thereof showing our new design;
FIG. 2 is a rear elevation view thereof;
FIG. 3 is a top plan view thereof;
FIG. 4 is a right side elevation view thereof;
FIG. 5 is a left side elevation view thereof;
FIG. 6 is a front and right side perspective view thereof;
FIG. 7 is a front and left side perspective view thereof;
FIG. 8 is a rear and right side perspective view thereof; and,
FIG. 9 is a rear and left side perspective view thereof.
The broken lines in the drawings illustrate portions of the motorcycle and/or replica thereof that form no part of the claimed design.

U.S. PATENT DOCUMENTS

D444,103 S * 6/2001 Robb D12/110

D492,222 S * 6/2004 Uchiyama D12/110

D516,468 S * 3/2006 Kuboshima D12/110

D543,905 S * 6/2007 Domergue D12/110

D566,010 S * 4/2008 Hohdorf D12/110

D566,011 S * 4/2008 Hohdorf D12/110

D599,253 S * 9/2009 Isokari D12/110

D695,648 S * 12/2013 Yamazaki D12/110

D715,696 S * 10/2014 Sasanami D12/110

D718,670 S * 12/2014 Kiska D12/110

(Continued)

1 Claim, 5 Drawing Sheets

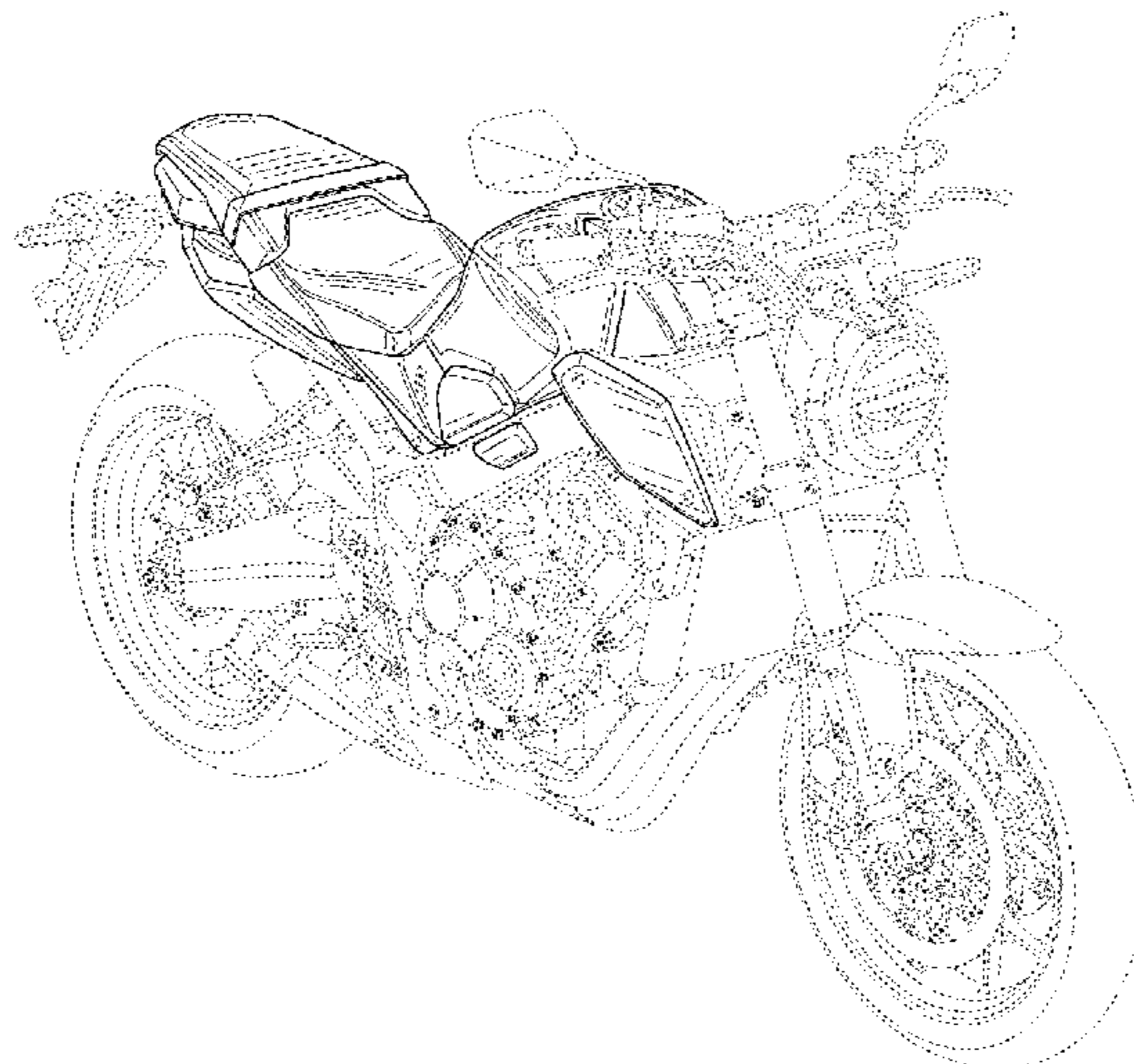

(56)

References Cited

U.S. PATENT DOCUMENTS

D723,430 S *	3/2015	Schmidt	D12/110
D734,216 S *	7/2015	Sasanami	D12/110
D756,269 S *	5/2016	Hahn-Woernle	D12/110
D793,285 S *	8/2017	Toyama	D12/110
D859,220 S *	9/2019	Kishi	D12/110
D859,221 S *	9/2019	Shigihara	D12/110
2010/0025140 A1 *	2/2010	Takenaka	B62K 11/14 180/219
2012/0318598 A1 *	12/2012	Fujiyama	B60K 5/12 180/219

FOREIGN PATENT DOCUMENTS

JP	1585637 S	11/2017
JP	1598940 S	3/2018
JP	1598942 S	3/2018
JP	1598944 S	3/2018
TW	D124155 S	8/2008
TW	D145785 S	3/2012

TW	D146782 S	5/2012
TW	D157571 S	12/2013
TW	D164306 S	11/2014
TW	D168293 S	6/2015
TW	D171215 S	10/2015
TW	D171307 S	10/2015
TW	D171872 S	11/2015
TW	D179460 S	11/2016
TW	D180754 S	1/2017

OTHER PUBLICATIONS

Japanese Magazine, "Mono Magazine", HA30002805, published on May 16, 2018, p. 32.

Japanese Magazine, "Motorcycle", HA30000982, published on Apr. 1, 2018, p. 23.

Japanese Magazine, "Motorcycle", HA30001585, published on May 1, 2018, p. 62.

Japanese Magazine, "Motorcycle", HA30000986, published on Apr. 1, 2018, p. 52.

* cited by examiner

FIG.1

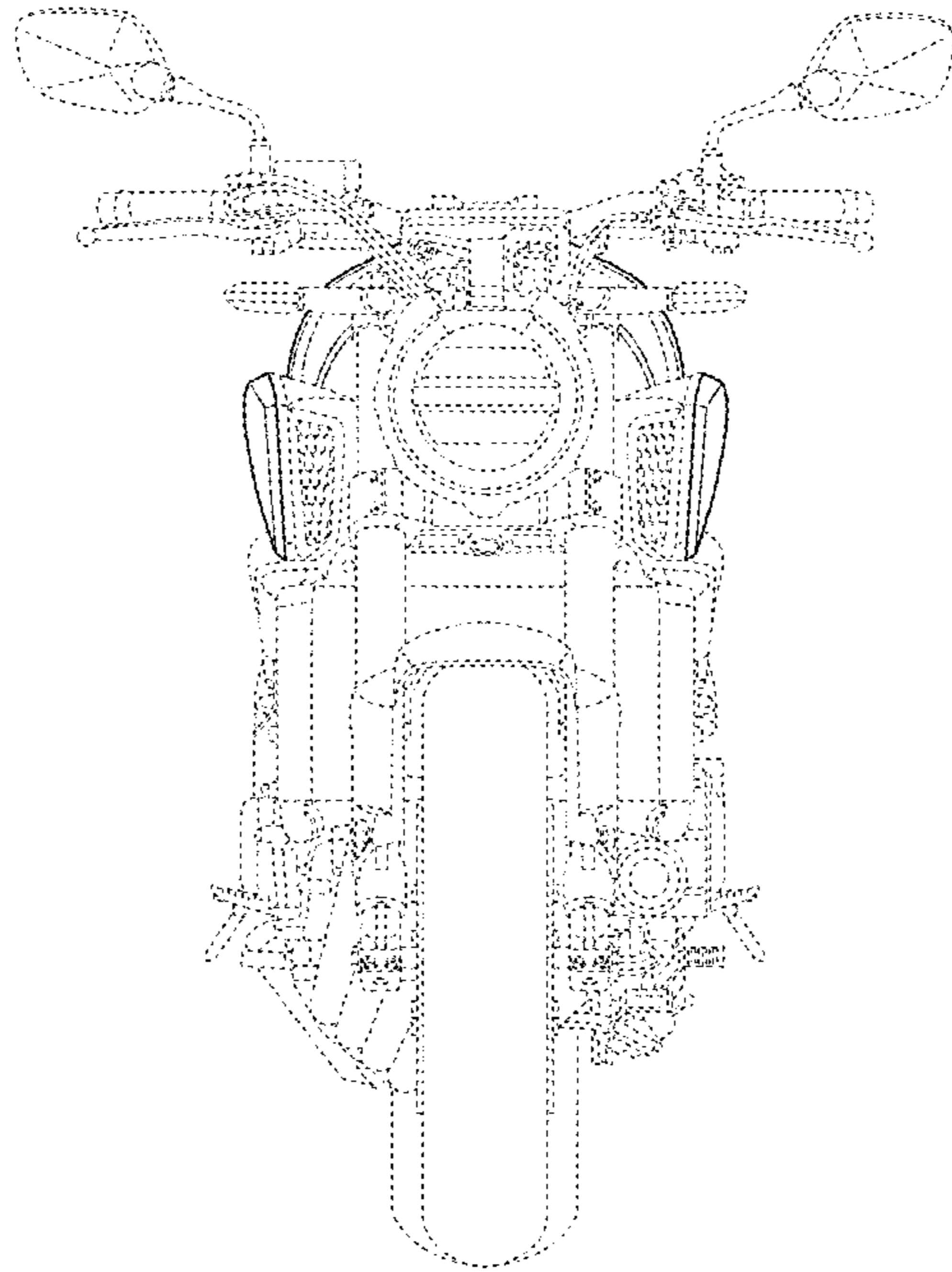

FIG.2

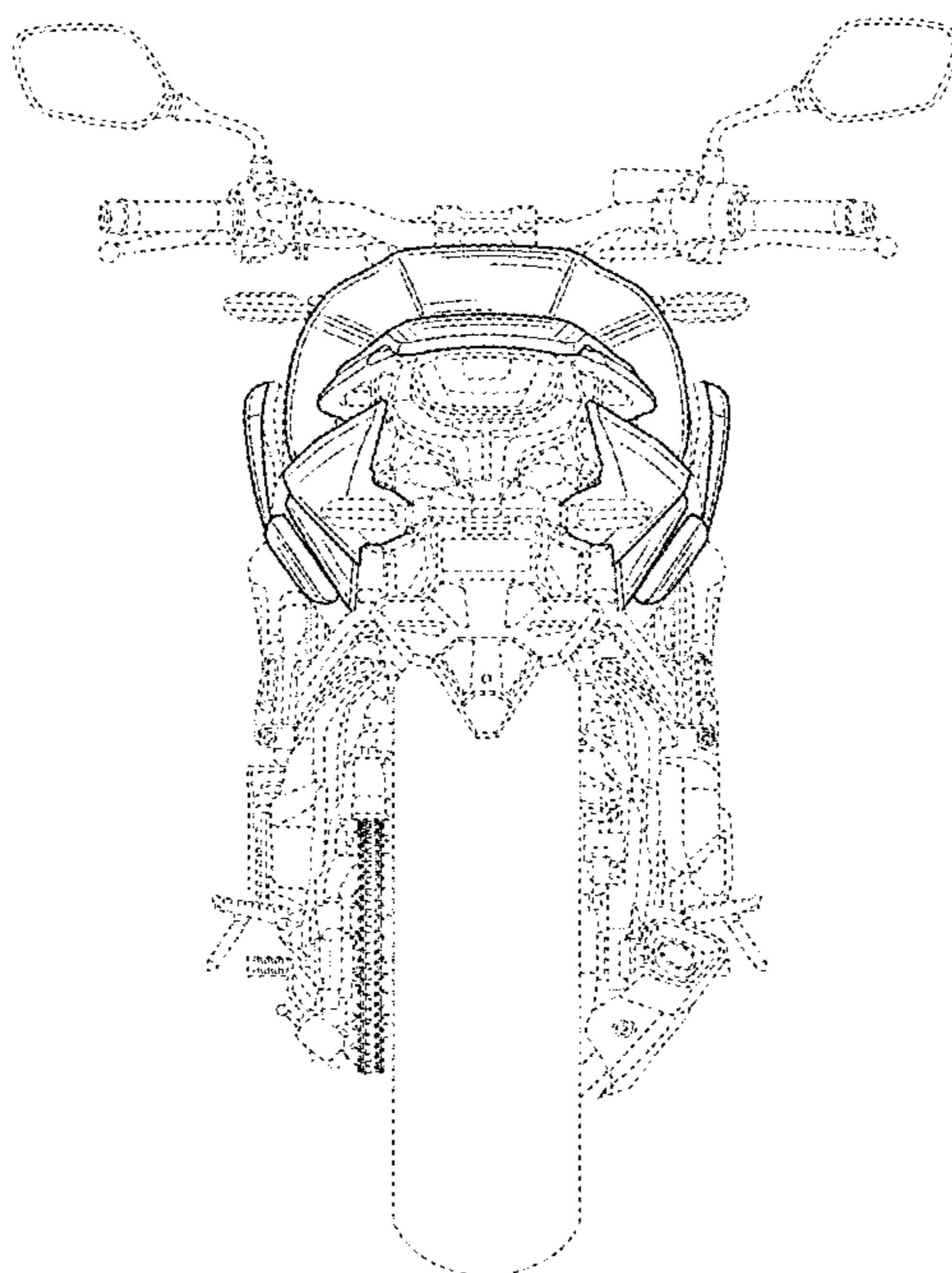

FIG.3

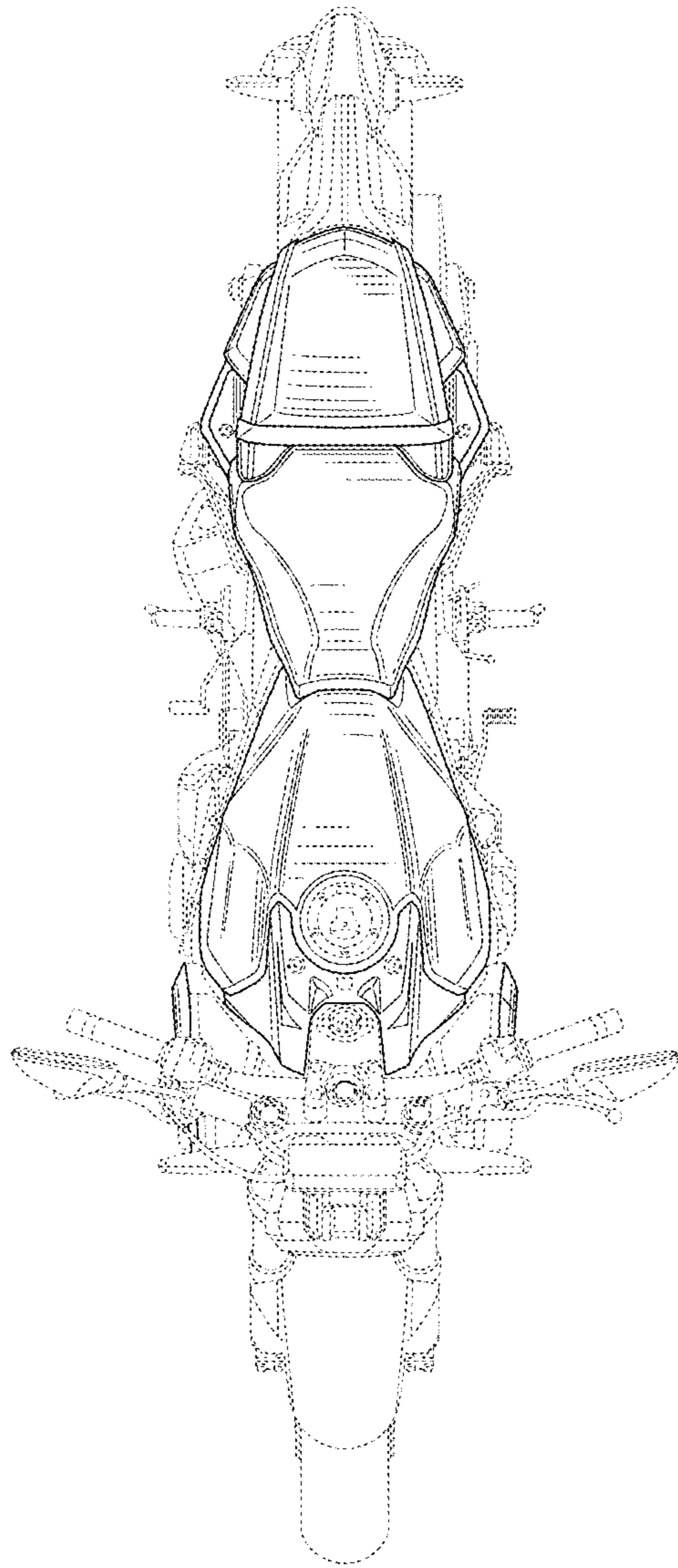

FIG.4

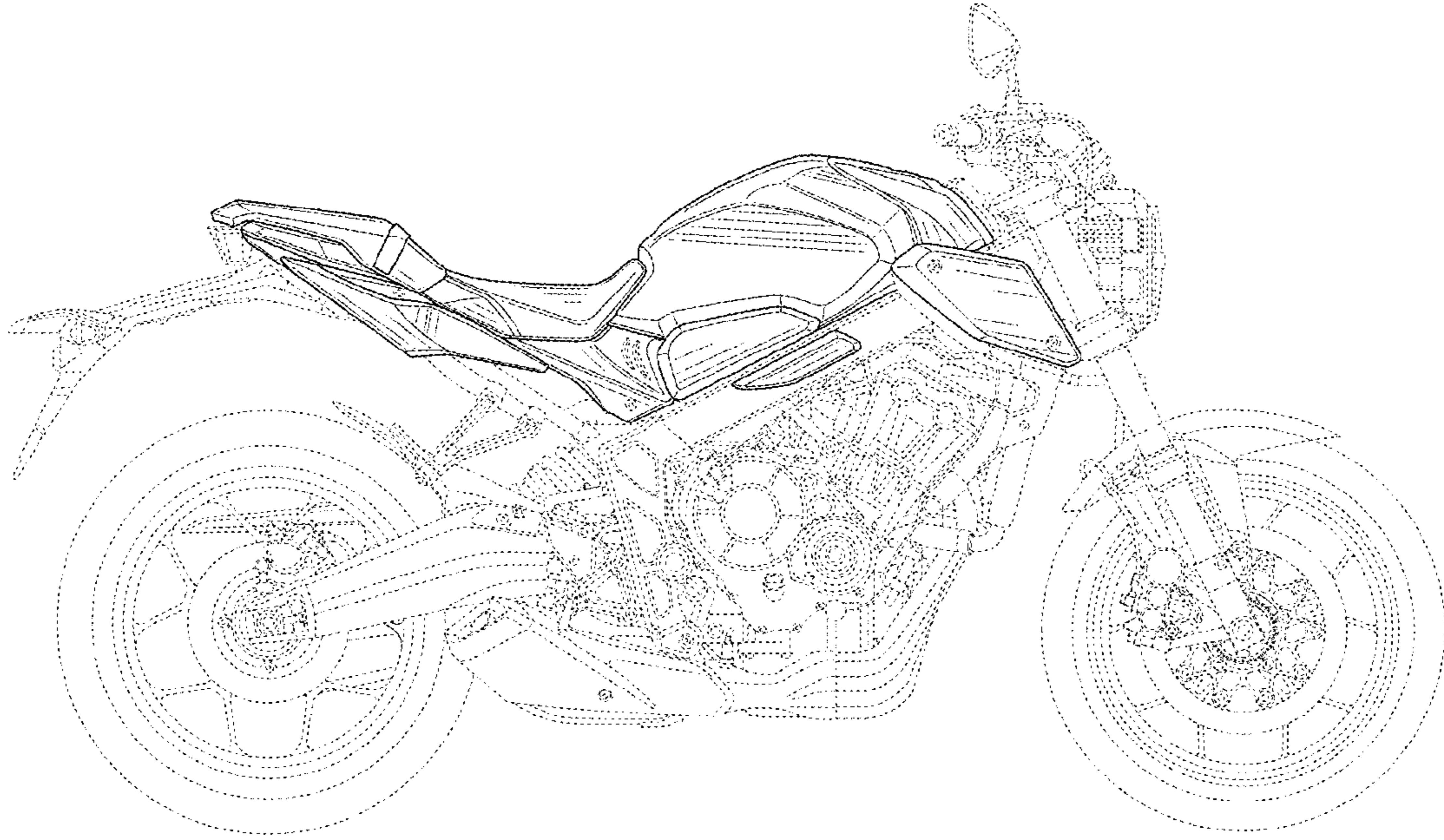

FIG.5

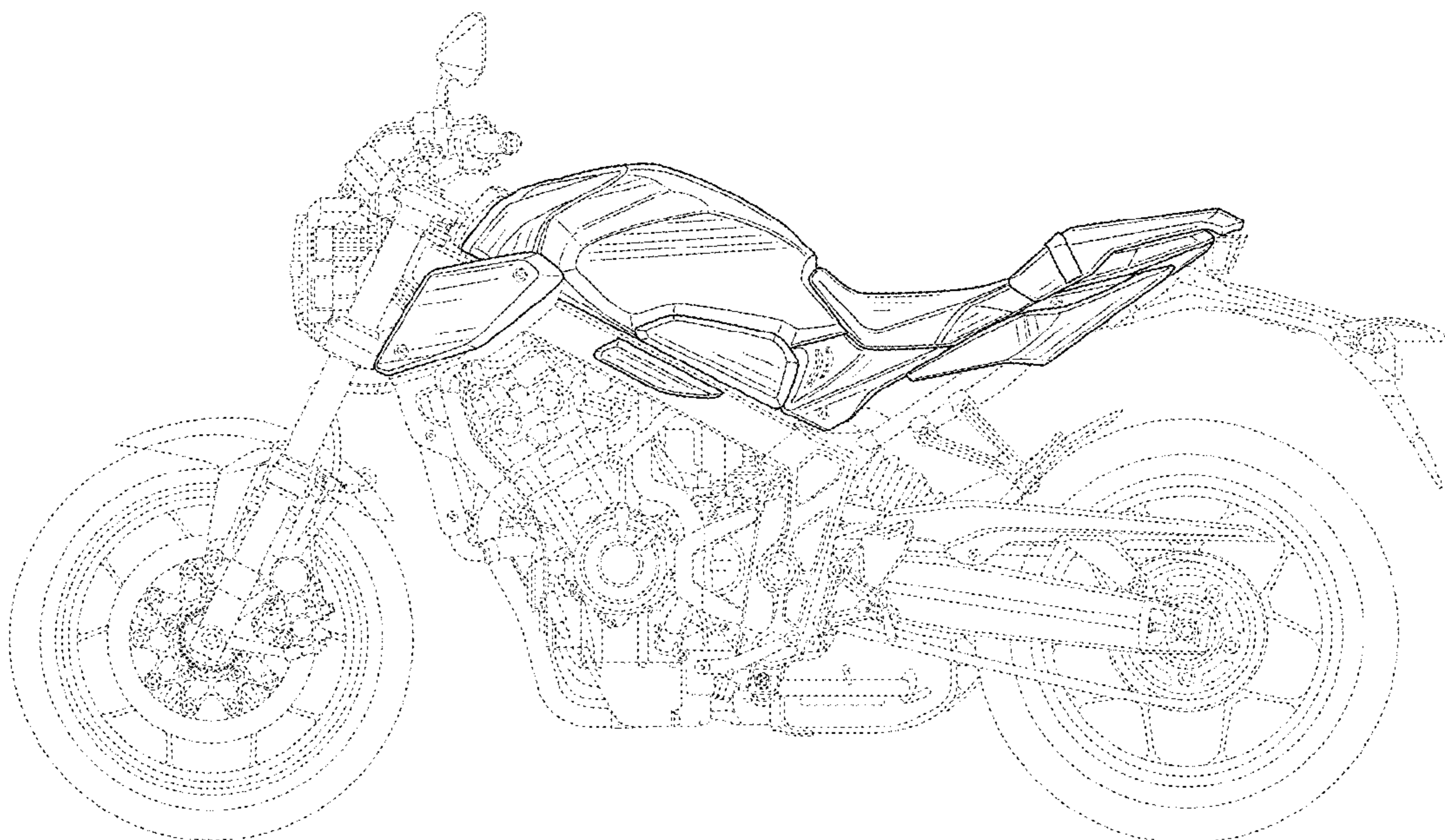

FIG.6

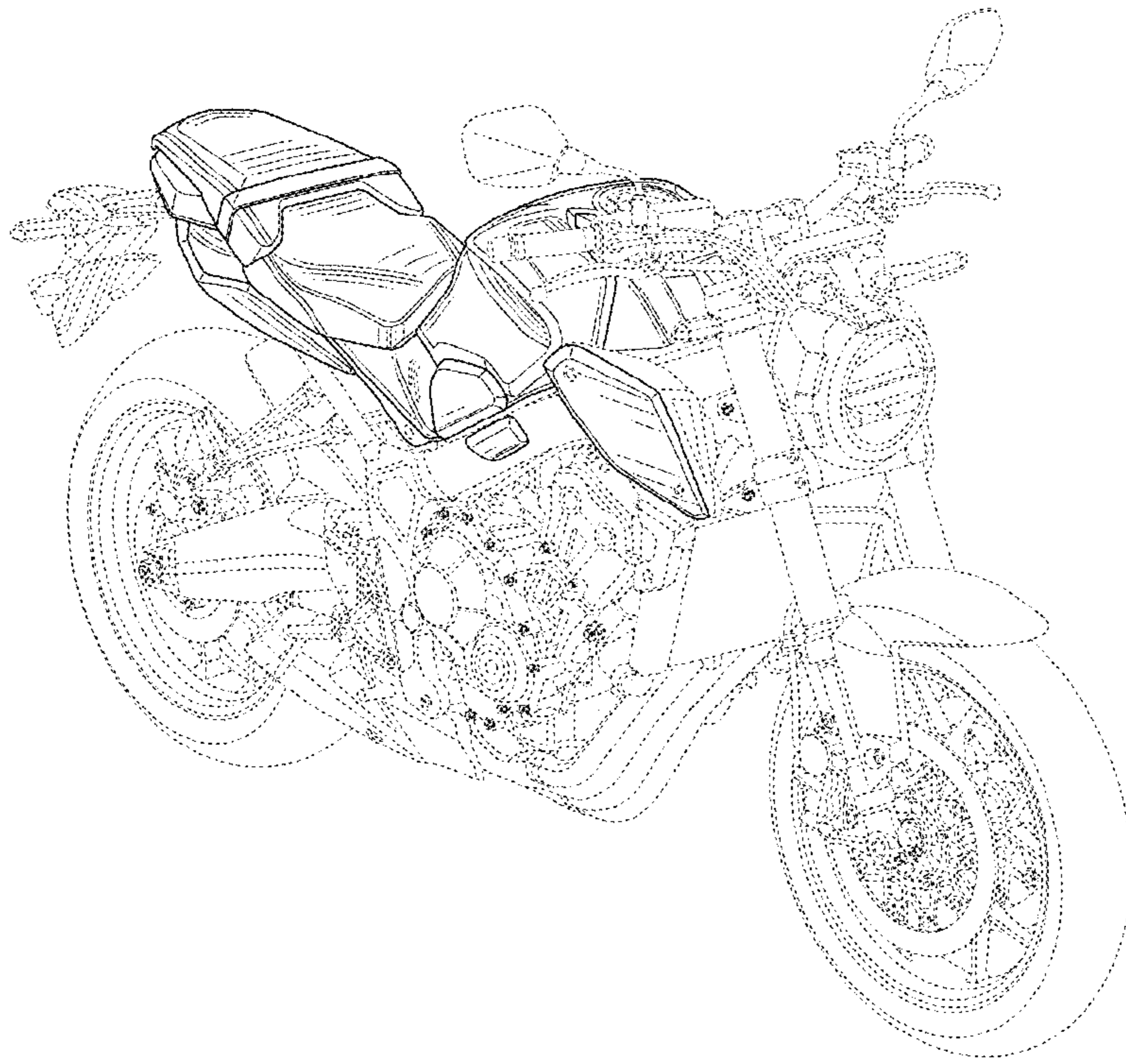

FIG.7

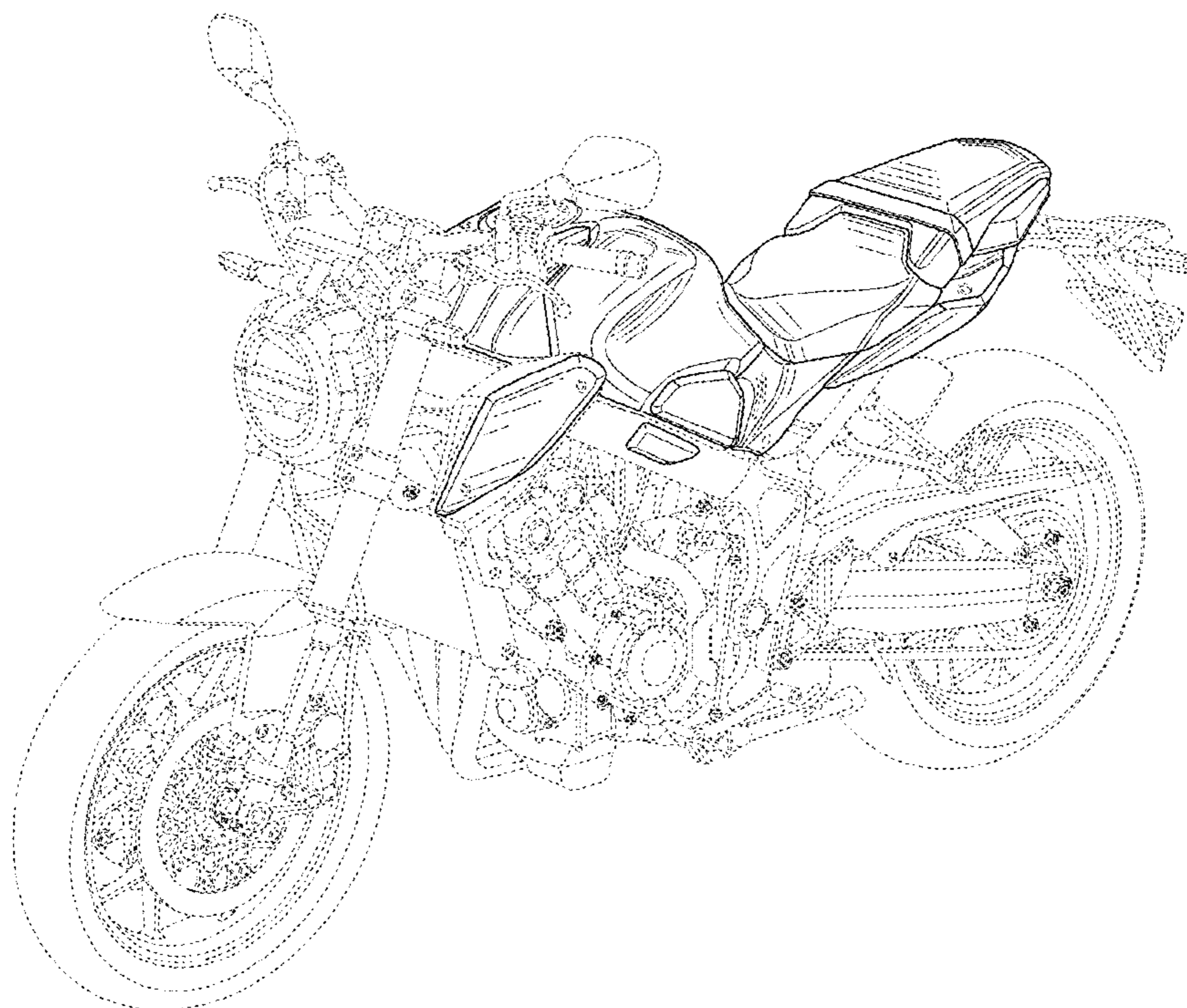

FIG.8

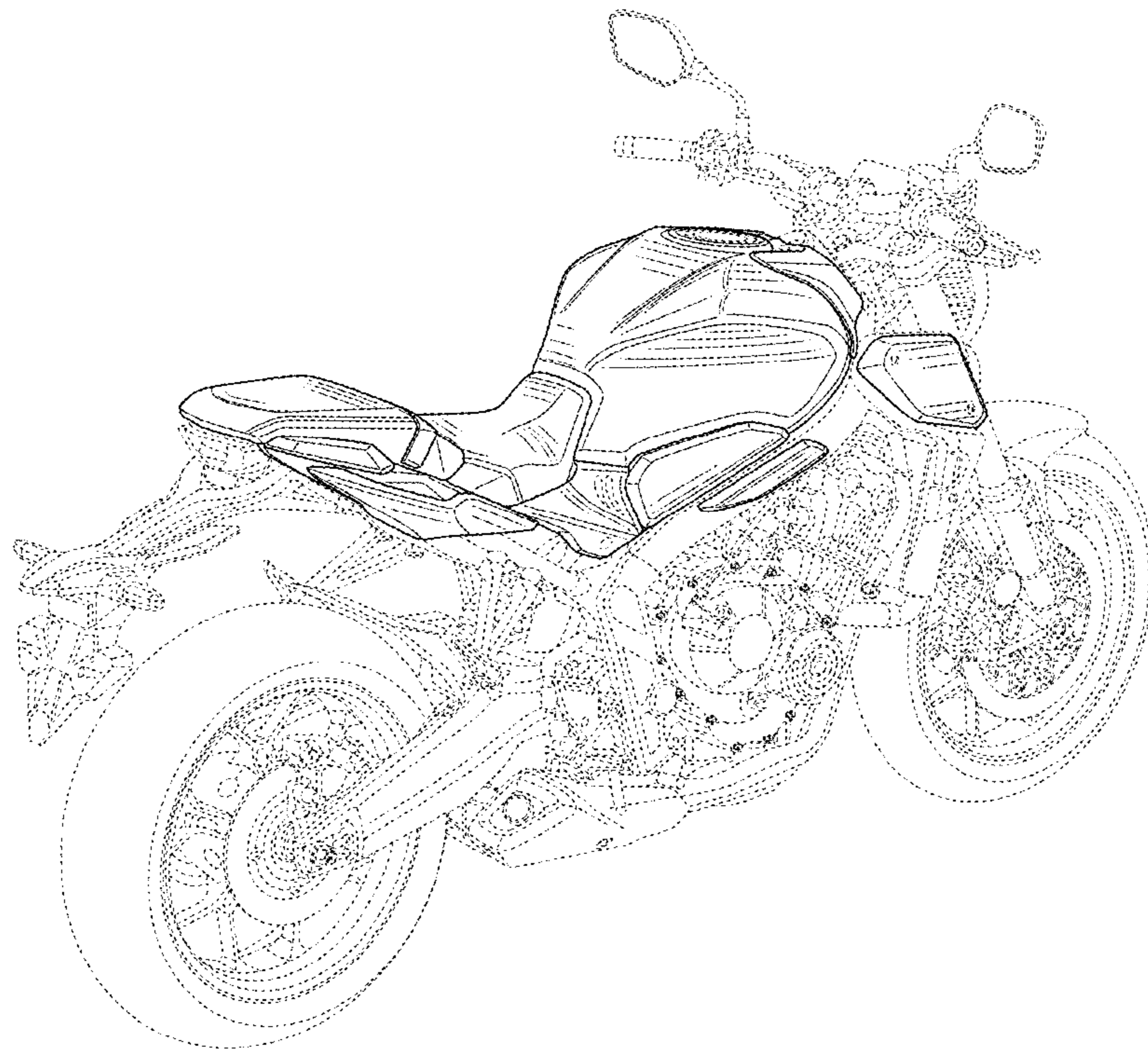

FIG.9

