



US00D876041S

(12) **United States Design Patent** (10) **Patent No.:** **US D876,041 S**
Wiskus (45) **Date of Patent:** **** Feb. 18, 2020**

(54) **DOLLY FOR AN AIRCRAFT**

FOREIGN PATENT DOCUMENTS

(71) Applicant: **West Metro Aviation, LLC.**, Buffalo, MN (US)

GB 1105364 3/1968

(72) Inventor: **Michael Wiskus**, Spring Park, MN (US)

OTHER PUBLICATIONS

(73) Assignee: **West Metro Aviation, LLC**, Buffalo, MN (US)

The Brackett Aircraft Company, Inc. [online] "Towbar Model TY-TB-FTD", First accessed on Mar. 3, 2014, Retrieved from the Internet: <http://www.brackettaircraft.com/TY-TB-FTDspec.sht.htm>, 2 pgs.

(**) Term: **15 Years**

(Continued)

(21) Appl. No.: **29/612,759**

Primary Examiner — Cynthia Ramirez

(22) Filed: **Aug. 3, 2017**

(74) *Attorney, Agent, or Firm* — Christensen, Fonder, Dardi & Herbert PLLC

Related U.S. Application Data

(63) Continuation of application No. 14/657,911, filed on Mar. 13, 2015, now abandoned.

(51) **LOC (12) Cl.** **12-02**

(52) **U.S. Cl.**
USPC **D34/23**

(58) **Field of Classification Search**
USPC D34/12, 18, 23; D12/345
CPC ... B62B 3/02; B62B 3/12; B62B 3/125; B64F 1/227; B64F 1/22; B66F 7/246; B60B 30/02; B60B 30/10
See application file for complete search history.

(57) **CLAIM**

I claim the ornamental design for a dolly for an aircraft, as shown and described.

DESCRIPTION

FIG. 1 is a front, top perspective view of a dolly for an aircraft showing my new design; FIG. 2 is a rear, top perspective view thereof; and, FIG. 3 is another rear, top, perspective view thereof. The portions of the drawings depicted in broken lines illustrate structure or features that form no part of the claim design.

We understand embodiments of our inventions includes different combinations of such discrete components as illustrated by the drawings herein and in the applications incorporated by reference. Whereby we reserve the right and contemplate making solid lines dashed for any specific feature or component, part, or portion in the various embodiments illustrated herein and in the drawings of the applications incorporated by reference herein as we have contemplated such as being embodiments of our invention, and we reserve the right and contemplate making dashed lines solid for any specific feature or component, part, or portion.

(56) **References Cited**

U.S. PATENT DOCUMENTS

834,146 A	10/1906	Lewis	
1,248,896 A	12/1917	Olson	
1,419,067 A	6/1922	McCarthy	
1,751,874 A	3/1930	Moore	
1,802,809 A *	4/1931	Funk	B62B 5/0083 280/47.23
1,819,625 A	8/1931	Schroeder	

(Continued)

1 Claim, 3 Drawing Sheets

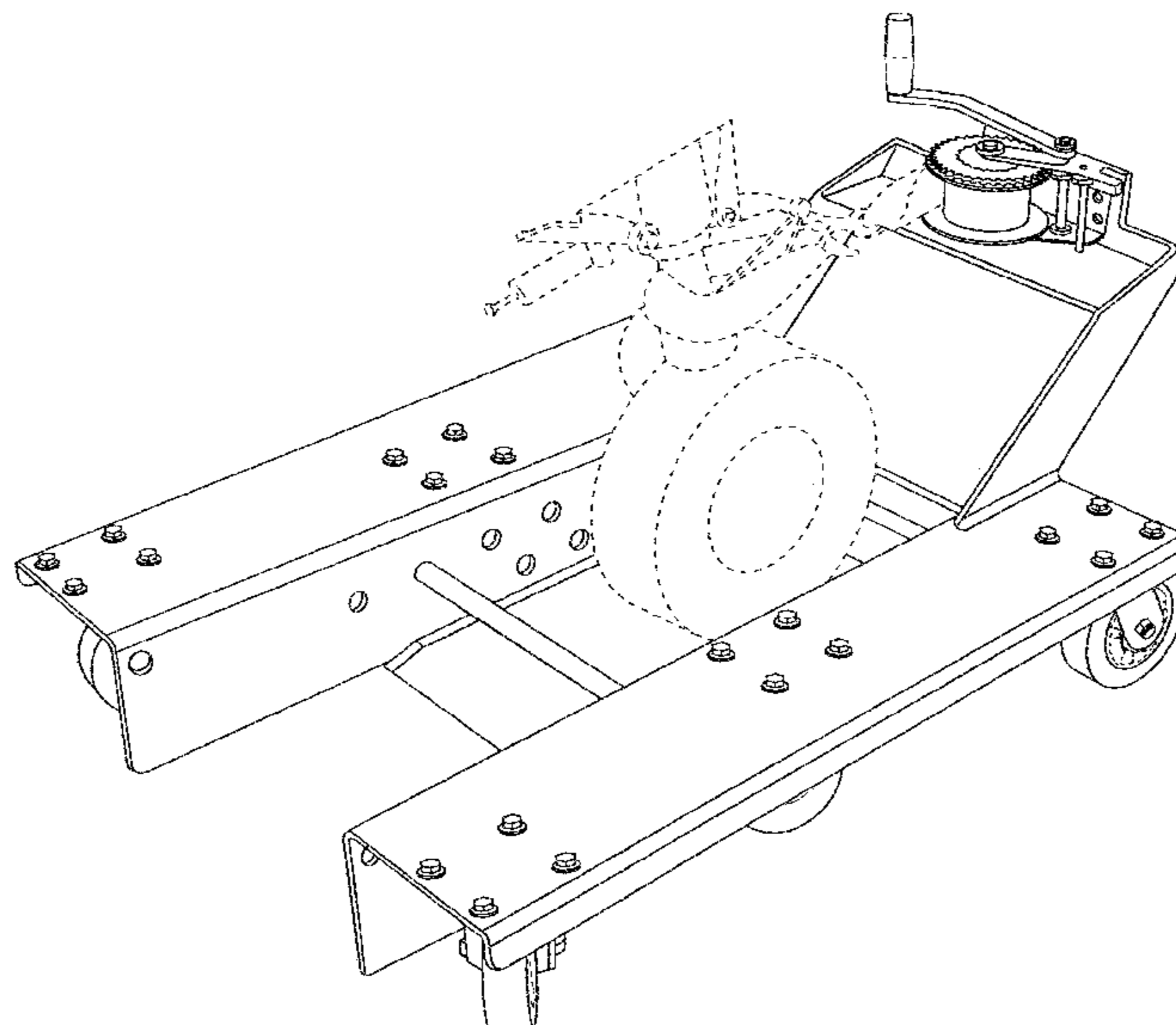

(56)

References Cited

U.S. PATENT DOCUMENTS

1,902,834 A * 3/1933 Cohen-Venezian B64F 1/22
280/1

2,222,111 A 11/1940 McCarthy
2,362,981 A 11/1944 Baum
2,392,409 A 1/1946 Ray
2,576,544 A 11/1951 Smith
2,608,312 A 8/1952 Day
2,610,750 A 9/1952 Hulbert
2,980,270 A 4/1961 Elliott et al.
3,024,036 A 3/1962 Reynolds
3,583,723 A 6/1971 Nowell
3,586,187 A 6/1971 Wright
3,598,259 A 8/1971 Wright
3,720,422 A 3/1973 Nelson
3,946,886 A 3/1976 Robinson
4,036,384 A 7/1977 Johnson
4,212,580 A 7/1980 Fluck
4,286,800 A * 9/1981 Lomas B60P 3/1033
280/414.1

4,429,897 A * 2/1984 Friedman B62B 1/12
280/47.24

4,690,605 A 9/1987 Coccaro
4,854,803 A * 8/1989 Coccaro B60B 29/002
414/429

4,968,210 A 11/1990 Friederich
5,071,151 A 12/1991 Irwin
D354,263 S * 1/1995 Clark D12/162
5,386,737 A 2/1995 Soeder et al.
D357,888 S * 5/1995 Geddes D12/101
D365,315 S * 12/1995 Parker, Jr. D12/162
5,511,929 A 4/1996 Loftus
D384,316 S * 9/1997 Freeman, Jr. D12/162
5,666,747 A * 9/1997 MacQueen E01H 5/06
280/79.11

5,791,593 A * 8/1998 Warren, III B64C 25/52
244/103 R

6,024,374 A * 2/2000 Friesen B60D 1/06
280/47.27

6,450,756 B1 9/2002 Stahancyk et al.
D475,497 S * 6/2003 DiStaulo D34/28
D475,829 S * 6/2003 DiStaulo D34/28
6,663,136 B2 * 12/2003 Stevens B60D 1/075
280/47.27

7,040,556 B2 5/2006 Jones
7,074,003 B2 * 7/2006 Klein B64F 1/22
244/17.17

7,097,406 B1 8/2006 Gang
7,234,665 B2 * 6/2007 MacGregor B64F 1/224
244/50

7,607,608 B2 10/2009 Morris et al.
7,845,670 B2 * 12/2010 Oberg B60D 1/66
280/47.24

8,336,900 B2 * 12/2012 Perry B60S 13/00
180/904

8,366,373 B2 2/2013 Wood
8,475,108 B2 7/2013 Hamman
8,496,230 B1 7/2013 Jiron
8,534,980 B2 9/2013 Kuramoto
8,967,637 B2 * 3/2015 Perry B60P 3/11
280/47.34

9,108,463 B2 * 8/2015 Winters B60B 30/02
9,108,477 B2 * 8/2015 Van Der Lelij B60D 1/02
9,452,767 B2 * 9/2016 Falcaro B62B 1/20
10,124,822 B2 * 11/2018 Nielsen B62B 5/0079
10,214,229 B2 * 2/2019 Brown B62B 3/001
2003/0021661 A1 1/2003 Fluss
2014/0037409 A1 2/2014 Winters

OTHER PUBLICATIONS

Airtug®, [online] “NFE-4 Aircraft Tug”, First accessed on Mar. 3, 2014, Retrieved from the Internet: <http://airtug.com/products/aircraft-tugs/the-cirrus-airtug-tug/>, 8 pgs.

* cited by examiner

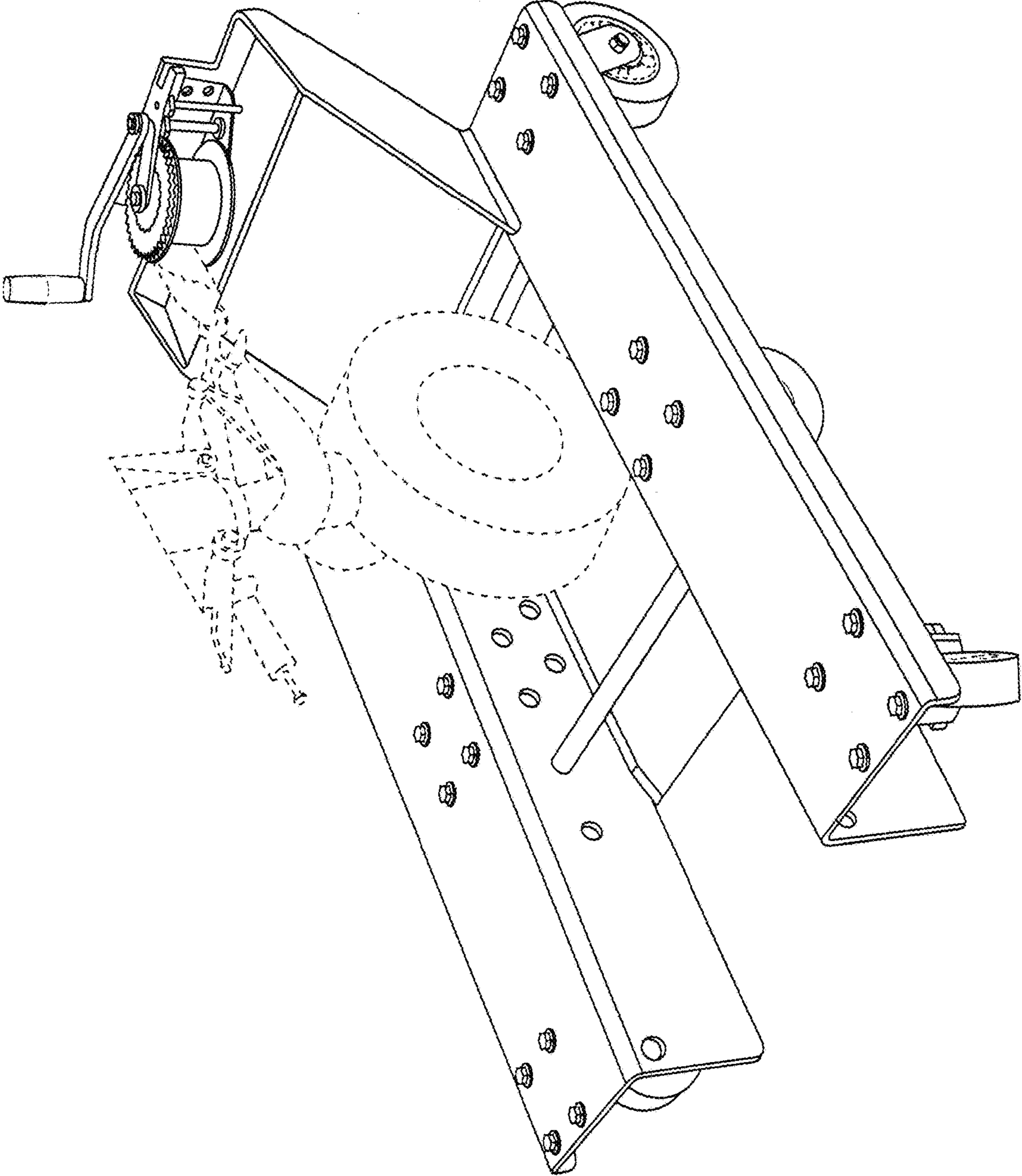

FIG. 1

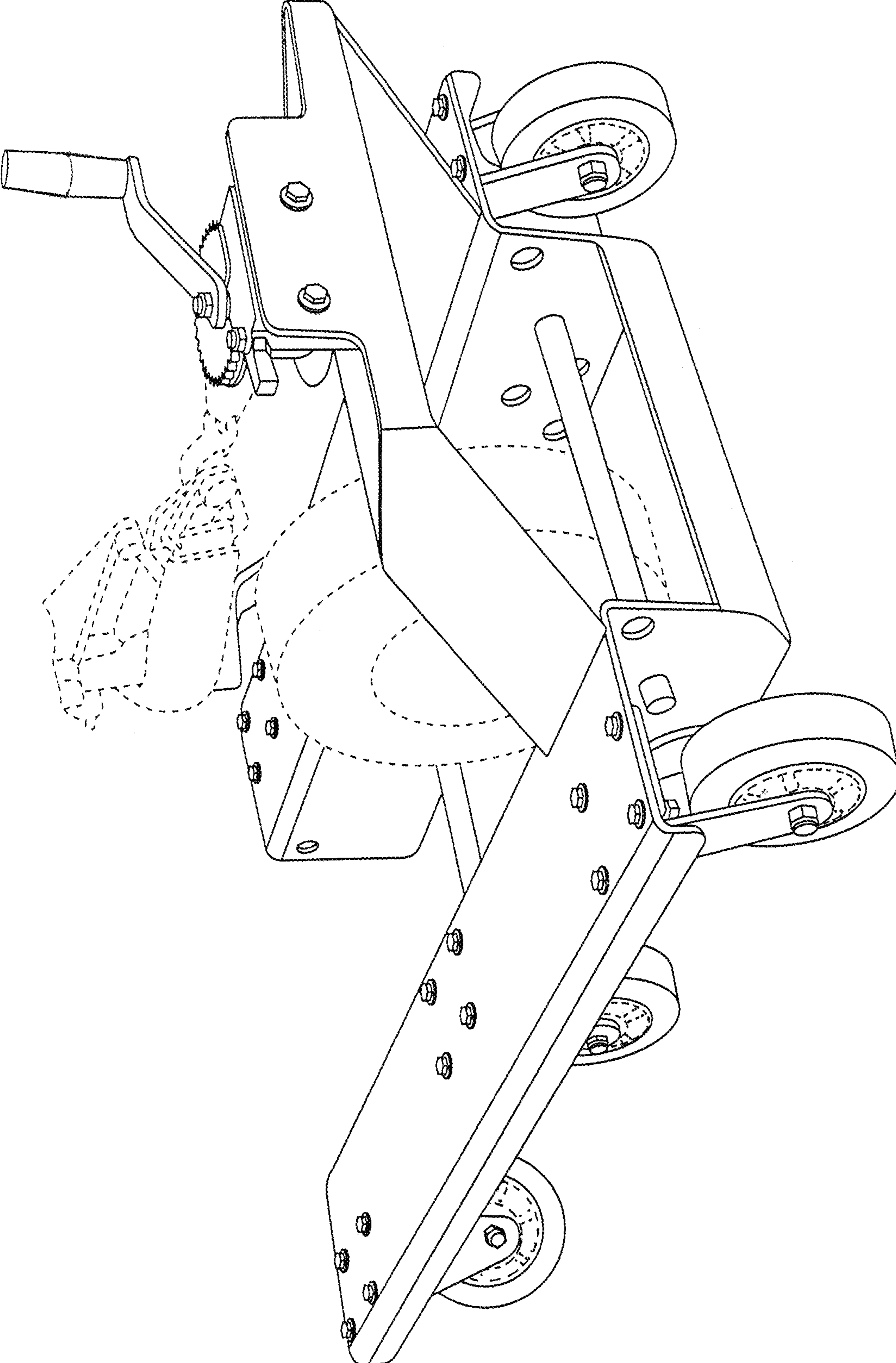

FIG. 2

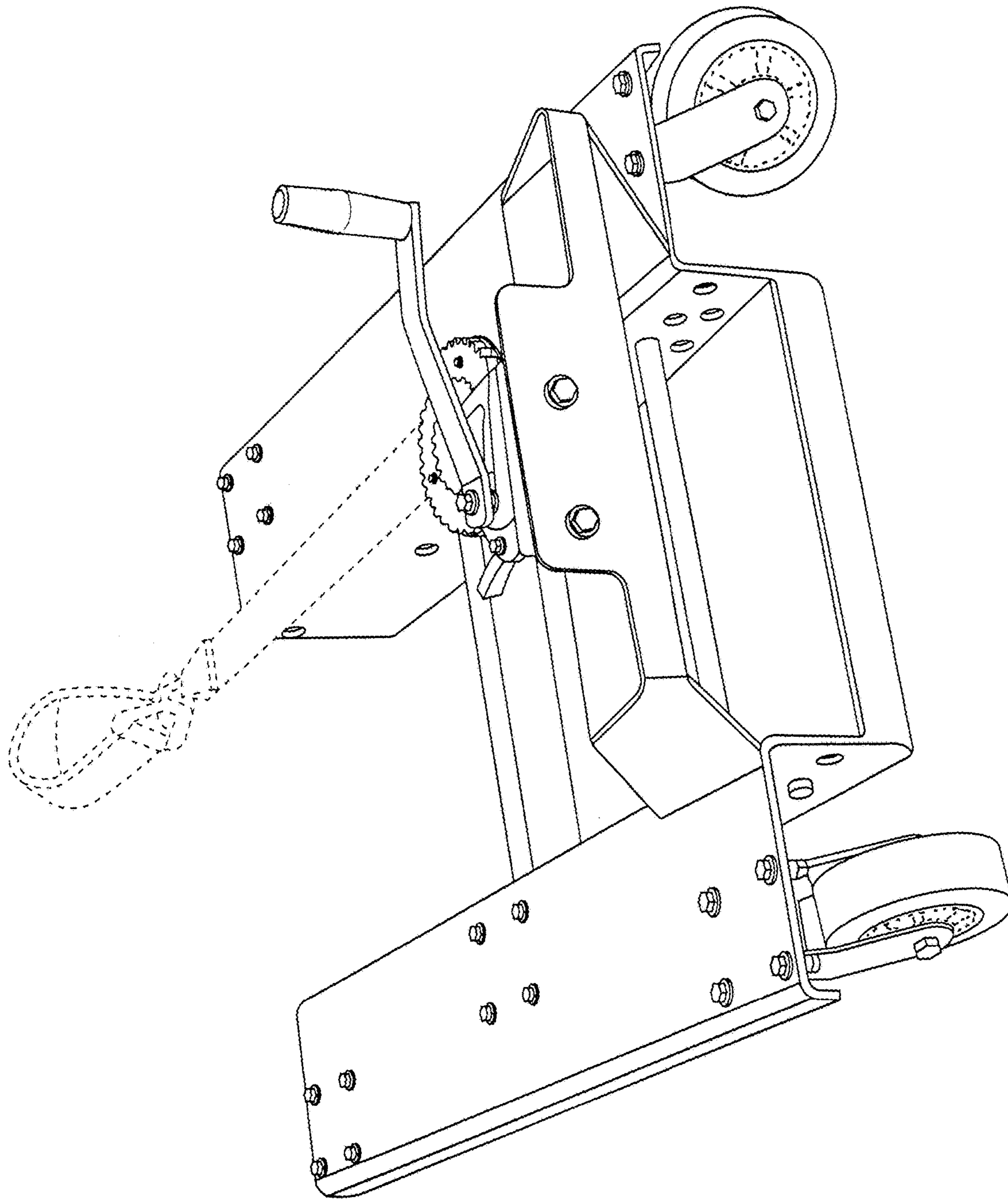

FIG. 3