



US00D875969S

(12) **United States Design Patent** (10) **Patent No.:** **US D875,969 S**  
**Jaskiewicz et al.** (45) **Date of Patent:** **\*\* Feb. 18, 2020**

(54) **THRESHOLD CAP**  
(71) Applicant: **Endura Products, Inc.**, Colfax, NC (US)  
(72) Inventors: **Tomasz Jaskiewicz**, Oak Ridge, NC (US); **Michael K. Mitchell**, Winston-Salem, NC (US)  
(73) Assignee: **Endura Products, Inc.**, Colfax, NC (US)

220,460 A 10/1879 York  
313,742 A 3/1885 Kintner  
394,864 A 12/1888 Lathrop  
435,658 A 9/1890 Brennaman  
500,885 A 7/1893 Green et al.  
582,451 A 5/1897 Brannon  
600,301 A 3/1898 Barger  
618,013 A 1/1899 Roeder  
1,468,958 A 9/1923 Champion  
(Continued)

(\*\*) Term: **15 Years**  
(21) Appl. No.: **29/601,563**  
(22) Filed: **Apr. 24, 2017**

**FOREIGN PATENT DOCUMENTS**

CA 166338 \* 9/2016  
CA 166339 \* 9/2016  
(Continued)

**Related U.S. Application Data**

(63) Continuation-in-part of application No. 29/534,779, filed on Jul. 31, 2015, which is a continuation-in-part of application No. 14/717,194, filed on May 20, 2015, now Pat. No. 9,528,314.

**OTHER PUBLICATIONS**

<https://www.enduraproducts.com/products/sills-sill-systems/> Available Dec. 2016 (Year: 2016).\*

(Continued)

(51) **LOC (12) Cl.** ..... **25-02**  
(52) **U.S. Cl.**

*Primary Examiner* — Leanne Was-Englehart

(74) *Attorney, Agent, or Firm* — Womble Bond Dickinson (US) LLP

USPC ..... **D25/48.2**  
(58) **Field of Classification Search**  
USPC ..... D25/48.1–48.4, 48.8, 55, 60, 119–125, D25/164, 199  
CPC ..... E06B 7/18; E06B 7/22; E06B 7/26; E06B 7/231; E06B 7/2305; E06B 7/2309; E06B 7/2312; E06B 7/2314; E06B 7/2316; E06B 1/70; E06B 3/28; A62C 3/14; B60J 10/16; B60J 10/86; B60J 10/235  
See application file for complete search history.

(57) **CLAIM**

The ornamental design for a threshold cap, as shown and described.

**DESCRIPTION**

FIG. 1 is a profile view of our new design; FIG. 2 is a top perspective view thereof; and, FIG. 3 is a bottom perspective view thereof. The views not shown form no part of the claimed design. The dash-dot lines in the figures adjacent to the shaded areas represent unclaimed boundaries of the claimed design. The dash-dash lines in the figures represent portions and environmental elements that form no part of the claimed design.

(56) **References Cited**  
U.S. PATENT DOCUMENTS  
56,046 A 7/1866 Hawkins  
126,014 A 4/1872 Brown et al.

**1 Claim, 3 Drawing Sheets**

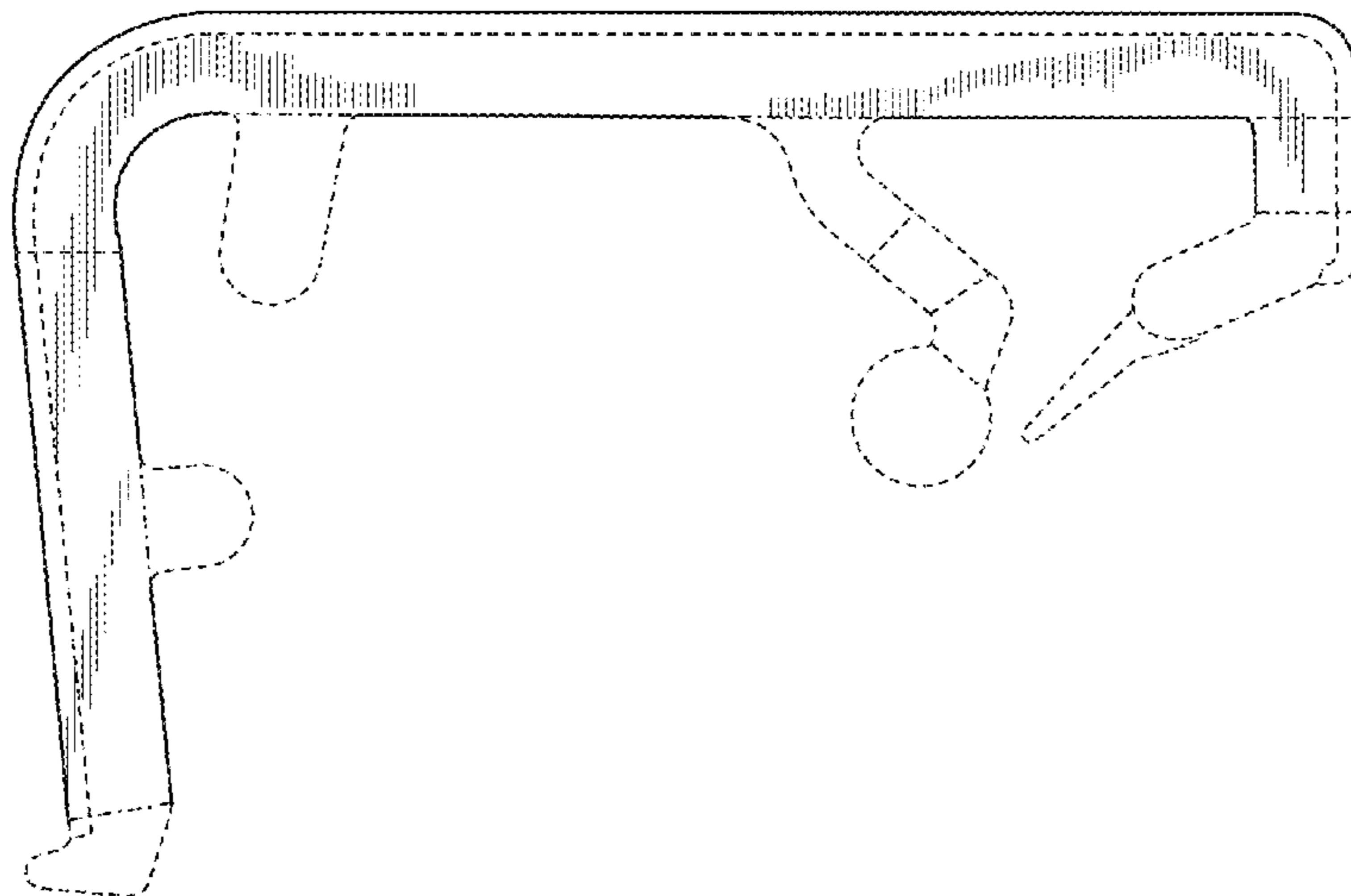

(56)

References Cited

U.S. PATENT DOCUMENTS

1,595,827 A 8/1926 Frisque  
 1,795,853 A 3/1931 Glass  
 1,993,506 A 10/1933 Fauner  
 2,108,137 A 2/1938 Oftedal et al.  
 2,129,381 A 9/1938 Oftedal et al.  
 2,202,482 A 5/1940 Dahl  
 2,579,875 A 12/1951 Stanko  
 2,663,056 A 12/1953 Hardgrave  
 2,696,029 A 12/1954 Neff  
 2,728,118 A 12/1955 Gossen  
 2,818,614 A 1/1958 Lapka, Jr.  
 3,083,420 A 4/1963 Tinflow  
 3,114,180 A 12/1963 Riedl  
 3,273,287 A 9/1966 Pease, Jr.  
 3,374,579 A 3/1968 Neff  
 3,402,512 A 9/1968 Peterson  
 3,432,966 A 3/1969 Bordner  
 3,475,866 A 11/1969 Johansen  
 3,762,100 A 10/1973 Kempel  
 3,854,246 A 12/1974 McAllister  
 3,900,967 A 8/1975 Bursk et al.  
 3,962,828 A 6/1976 McAllister  
 3,967,412 A 7/1976 Governale  
 4,055,917 A 11/1977 Coller  
 4,073,093 A 2/1978 Ookawa et al.  
 4,079,550 A 3/1978 Bursk et al.  
 4,104,830 A 8/1978 Eagle  
 4,146,995 A 4/1979 Britt  
 4,156,325 A 5/1979 McMullen et al.  
 4,213,275 A 7/1980 Oehmig  
 4,224,766 A 9/1980 Procton  
 4,287,684 A 9/1981 McKann  
 4,310,991 A 1/1982 Seely  
 4,352,258 A 10/1982 Bursk et al.  
 4,387,535 A 6/1983 Corbo  
 4,411,104 A 10/1983 St. Aubin  
 4,447,987 A 5/1984 Lesosky  
 4,447,989 A 5/1984 Malland et al.  
 4,513,536 A 4/1985 Giguere  
 4,525,953 A 7/1985 Stutzman  
 4,625,457 A 12/1986 Avery  
 4,628,639 A 12/1986 Lownsdale  
 4,716,683 A 1/1988 Minter  
 4,831,779 A 5/1989 Kehrl et al.  
 5,010,690 A 4/1991 Geoffrey  
 5,012,614 A 5/1991 Shea  
 5,018,307 A 5/1991 Burrous et al.  
 5,067,279 A 11/1991 Hagemeyer  
 5,136,814 A 8/1992 Headrick  
 5,179,804 A 1/1993 Young  
 5,230,181 A 7/1993 Geoffrey et al.  
 5,426,894 A 6/1995 Headrick  
 5,588,266 A 12/1996 Headrick  
 5,592,782 A 1/1997 Scott  
 5,638,641 A 6/1997 Joffe et al.  
 5,675,935 A 10/1997 Lin  
 5,706,607 A 1/1998 Frey  
 5,857,291 A 1/1999 Headrick  
 5,943,825 A 8/1999 Procton et al.  
 6,006,375 A 12/1999 Carr  
 6,052,949 A 4/2000 Procton et al.  
 6,061,967 A 5/2000 Judda  
 6,125,584 A 10/2000 Sanders  
 6,138,413 A 10/2000 Fehr  
 6,216,395 B1 4/2001 Kelly  
 6,345,477 B1 2/2002 Kepler et al.  
 6,367,201 B1 4/2002 Massey  
 6,371,188 B1 4/2002 Baczuk et al.  
 6,484,446 B2 11/2002 Young  
 D488,243 S 4/2004 Babka et al.  
 6,763,639 B2 7/2004 Bennett et al.  
 6,789,358 B2 9/2004 Procton et al.  
 7,114,293 B2 10/2006 Purlee  
 D549,850 S 8/2007 Perlman  
 7,263,808 B2 9/2007 Massey et al.

7,350,336 B2 4/2008 Bennett  
 7,389,611 B2 6/2008 Palenske  
 7,472,516 B2 1/2009 Pepper et al.  
 7,600,346 B2 10/2009 Meeks  
 7,644,539 B2 1/2010 Baxter  
 7,669,369 B2 3/2010 Henry et al.  
 7,788,863 B2 9/2010 Pepper  
 D627,488 S 11/2010 Abdollahzadeh et al.  
 7,878,559 B2 2/2011 Meeks  
 D638,958 S \* 5/2011 Van Camp ..... D25/119  
 8,074,699 B2 12/2011 Jones et al.  
 8,371,069 B2 2/2013 O'Sullivan  
 8,413,383 B2 4/2013 Van Camp et al.  
 8,522,483 B2 \* 9/2013 Van Camp ..... E06B 1/70  
 49/303  
 D696,794 S 12/2013 Mossman  
 8,813,427 B2 \* 8/2014 Meeks ..... E06B 1/70  
 49/467  
 D722,387 S \* 2/2015 Van Camp ..... D25/48.2  
 8,991,100 B2 \* 3/2015 Van Camp ..... E06B 1/70  
 49/469  
 8,991,101 B2 3/2015 Van Camp  
 D733,927 S 7/2015 Van Camp  
 9,316,041 B2 4/2016 Olson  
 9,528,314 B2 \* 12/2016 Mitchell ..... E06B 7/18  
 9,725,945 B2 \* 8/2017 Swank ..... E06B 1/70  
 D797,309 S \* 9/2017 Jaskiewicz ..... D25/48.2  
 9,874,054 B2 \* 1/2018 Mitchell ..... E06B 7/18  
 2002/0194787 A1 12/2002 Bennett  
 2003/0005644 A1 1/2003 Reithmeyer et al.  
 2004/0139667 A1 7/2004 Massey et al.  
 2004/0200153 A1 10/2004 Khanlarian  
 2004/0256858 A1 12/2004 Governale  
 2005/0210754 A1 9/2005 Ferrell  
 2006/0053695 A1 3/2006 Palenske  
 2006/0174545 A1 8/2006 Young  
 2006/0283087 A1 12/2006 Baxter  
 2006/0283090 A1 12/2006 Moody  
 2007/0227076 A1 10/2007 Braun  
 2008/0110100 A1 5/2008 Heppner  
 2008/0229669 A1 9/2008 Abdollahzadeh et al.  
 2009/0199486 A1 8/2009 Wemiund et al.  
 2010/0107503 A1 5/2010 Chapman  
 2010/0257789 A1 10/2010 Meeks  
 2013/0047518 A1 2/2013 Van Camp et al.  
 2013/0199100 A1 \* 8/2013 Van Camp ..... E06B 1/70  
 49/468  
 2016/0145931 A1 5/2016 Meeks  
 2016/0340968 A1 \* 11/2016 Mitchell ..... E06B 7/18  
 2017/0101817 A1 \* 4/2017 Swank ..... E06B 1/70  
 2017/0298677 A1 \* 10/2017 Swank ..... E06B 1/70

FOREIGN PATENT DOCUMENTS

DE 19932332 2/2001  
 EP 327840 1/1989  
 GB 411361 6/1934  
 GB 3000477 \* 1/2002

OTHER PUBLICATIONS

AFCO Industries, Inc., Millwork Products Catalogue (52 pgs.), pp. cover page, 6 (vinyl cap) and 9 (riser), believed available as of 2012.  
 American Architectural Manufacturers Association, AAMA AG-11 AAMA Glossary (58 pgs.), believed to be available as of 2011, pp. 50 ("threshold"), 54 ("weatherstrip"), (<http://www.aamanet.org/general/1/241/skylight-glossary-of-terms>), accessed on Mar. 20, 2013).  
 Association of Millwork Distributors, Millwork Principles and Practices (6 pgs.), believed to be available as of 2010, pp. cover page, 130 (door sill), 131 (threshold), 160 (adjustable sill), 162 (weatherstrip).  
 Combo Aluminum Products, 50th Anniversary Catalog (59 pgs.), believed to be available 2008, cover page, pp. 1, 28 (hardwood cap), 31 (composite cap), 45 (foam weather-strip), ([http://www.comboaluminum.com/Catalog/Combo\\_Aluminum\\_Catalog.pdf](http://www.comboaluminum.com/Catalog/Combo_Aluminum_Catalog.pdf)), accessed Mar. 20, 2013).



(56)

**References Cited**

## OTHER PUBLICATIONS

Endura Products, Glossary, 7 pages (“Cap/Riser”, “Sill”, “Weatherstrip”), available as of Aug. 22, 2011 (<http://www.enduraproducts.com/technical-info/glossary.aspx>, accessed Mar. 20, 2013).

Official Action of U.S. Appl. No. 13/215,905, dated Feb. 15, 2013, 21 pgs.

Official Action of U.S. Appl. No. 13/215,905, dated Nov. 14, 2012, 18 pgs.

Profile Selection Guide Building Products Division (3 pgs.), Schlegel Systems, Inc., believed to be available as of Jun. 2008, page entitled T-Slot APTUS® TPE Weatherseals.

ThermaTru Doors Product Manual, Comp 13, Comp11, Jan. 2011 (online). Designs shown therein known at least as early as Aug. 24, 2010. Retrieved on Mar. 3, 2011: <URL: [www.thermatru.com/customer-support/technical-manuals/ArchComp/Comp-12-14.pdf](http://www.thermatru.com/customer-support/technical-manuals/ArchComp/Comp-12-14.pdf)>; <URL: <http://www.thermatru.com/customer-support/technical-manuals/manuals/ArchComp/Comp11.pdf>>, 6 pgs.

ThermaTru Doors Product Manual, Comp 13, Kerf Door Bottom, Jun. 2005, 2 pgs.

ThermaTru Doors, Sills Product Manual, Comp 11, Self-Adjusting Thermal Break Sill, Jun. 2005, 4 pgs.

Window & Door Manufacturers Association, The Door Glossary (9 pgs.), AAMA/WDMA/CSA 101/I.S.2/A440-11, NAFS—North American Fenestration Standard/Specification for Windows, Doors, and Skylights, believed to be available 2011, (<https://www.wdma.com/TechnicalCenter/TheDoorGlossary/tabid/84/Default.aspx>, accessed on Mar. 20, 2013).

Window & Door Manufacturers Association, The Window Glossary (11 pgs.), AAMA/WDMA/CSA 101/I.S.2/A440-11, NAFS—North American Fenestration Standard/Specification for Windows, Doors, and Skylights, believed to be available 2011, (<https://www.wdma.com/TechnicalCenter/TheWindowGlossary/tabid/109/Default.aspx>, accessed on Mar. 18, 2013).

\* cited by examiner

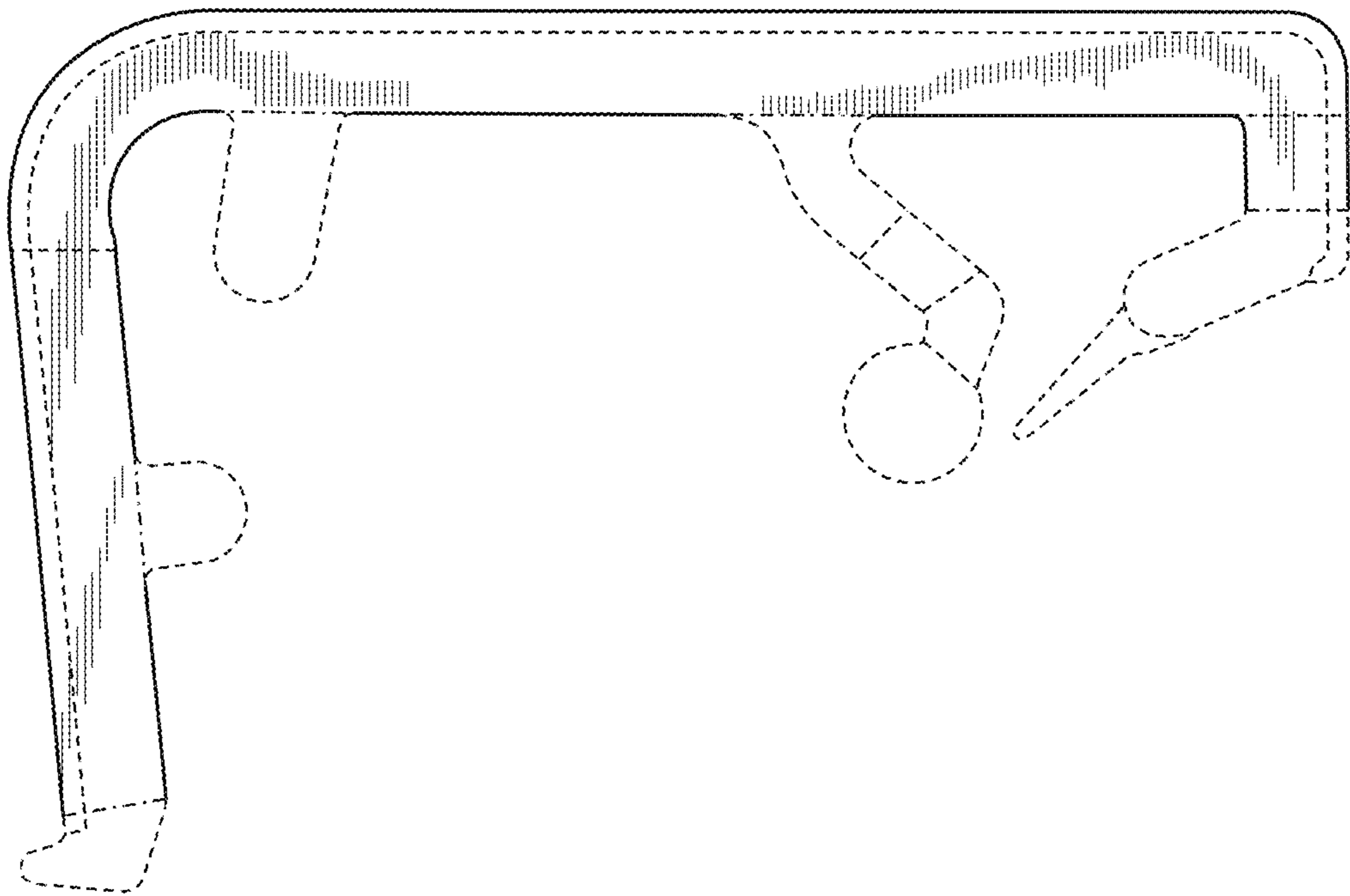

**FIG. 1**

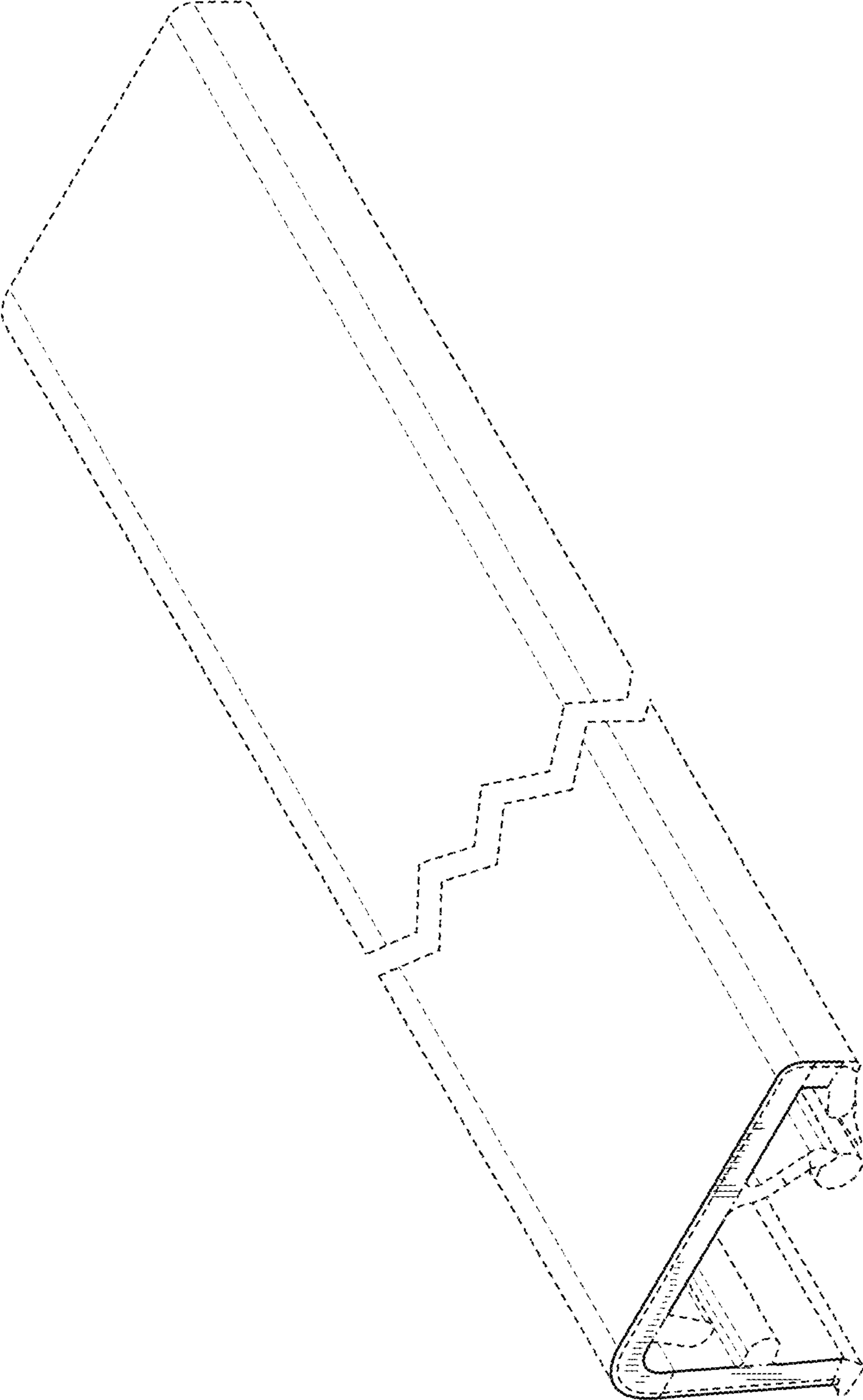

FIG. 2

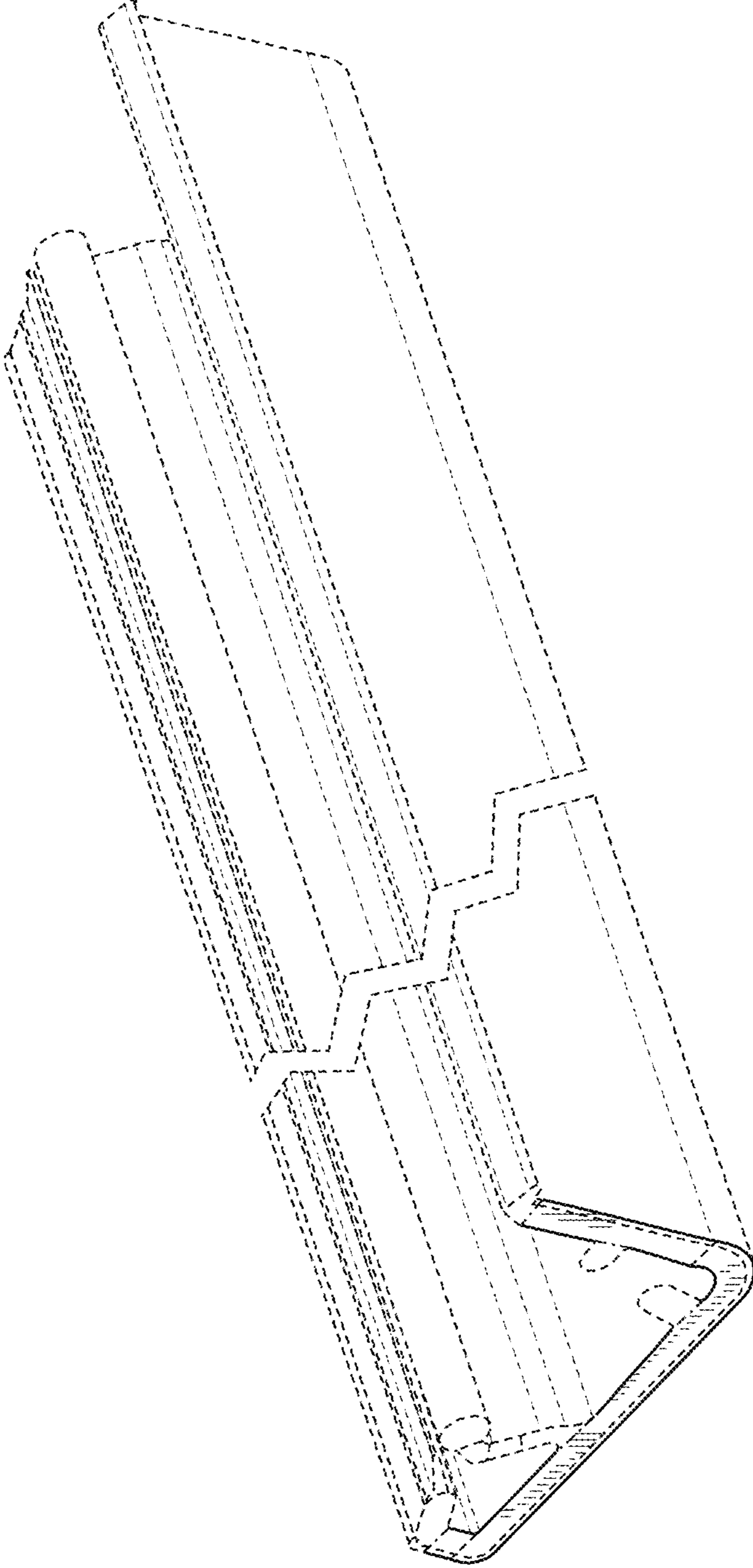

FIG. 3