



US00D875627S

(12) **United States Design Patent** (10) **Patent No.:** **US D875,627 S**
Duncan et al. (45) **Date of Patent:** **** Feb. 18, 2020**

(54) **FENDER**

(71) Applicant: **PACCAR Inc**, Bellevue, WA (US)

(72) Inventors: **Jonathan S. Duncan**, Seattle, WA (US); **Steven H. Hovind**, Renton, WA (US); **Scott D. Hite**, Pilot Point, TX (US); **Brent Johnson**, Denton, TX (US); **Tu H. Do**, Lewisville, TX (US); **Troy R. McCuller**, Corinth, TX (US)

(73) Assignee: **PACCAR Inc**, Bellevue, WA (US)

(**) Term: **15 Years**

(21) Appl. No.: **29/630,165**

(22) Filed: **Dec. 19, 2017**

(51) **LOC (12) Cl.** **12-16**

(52) **U.S. Cl.**
USPC **D12/184**

(58) **Field of Classification Search**
USPC D12/166, 167, 169, 171, 172, 181, 183, D12/190, 196, 216
CPC B60R 1/06; B62D 25/10; B62D 25/16; B62D 25/168
See application file for complete search history.

(56) **References Cited**

U.S. PATENT DOCUMENTS

D50,345 S	2/1917	Green	
D50,346 S	2/1917	Green	
4,392,669 A *	7/1983	Martin, Jr.	B60J 1/04 180/89.12
4,925,235 A *	5/1990	Fingerle	B60R 3/00 280/833
D319,036 S *	8/1991	Fingerle	D12/96
D320,582 S *	10/1991	Fingerle	D12/96
D366,638 S	1/1996	Tucker et al.	
D366,640 S	1/1996	Tucker et al.	
D378,812 S	4/1997	Aycock	

(Continued)

OTHER PUBLICATIONS

“AeroCab,” Kenworth Truck Company, Kirkland, Washington, 1993, 5-page brochure.

(Continued)

Primary Examiner — Susan Bennett Hattan

Assistant Examiner — Suzanne E Tisdell

(74) *Attorney, Agent, or Firm* — Seed IP Law Group LLP

(57) **CLAIM**

The ornamental design for a fender, as shown and described.

DESCRIPTION

FIG. 1 is a perspective view of a fender showing a first embodiment of our new design for one side of a vehicle; FIG. 2 is a perspective view of the fender of FIG. 1 without the environmental elements; FIG. 3 is a right side view of the fender shown in FIG. 2; FIG. 4 is a front view of the fender shown in FIG. 2; FIG. 5 is a rear view of the fender shown in FIG. 2; FIG. 6 is a top view of the fender shown in FIG. 2; FIG. 7 is a bottom view of the fender shown in FIG. 2; FIG. 8 is a perspective view of a fender showing a second embodiment of our new design for the other side of the vehicle; FIG. 9 is a perspective view of the fender of FIG. 8 without the environmental elements; FIG. 10 is a left side view of the fender shown in FIG. 9; FIG. 11 is a front view of the fender shown in FIG. 9; FIG. 12 is a rear view of the fender shown in FIG. 9; FIG. 13 is a top view of the fender shown in FIG. 9; and, FIG. 14 is a bottom view of the fender shown in FIG. 9. The broken lines shown in the figures represent portions of the fender that form no part of the claimed design. Phantom lines comprising long dashes separated by pairs of short dashes show environmental elements associated with the fender.

1 Claim, 8 Drawing Sheets

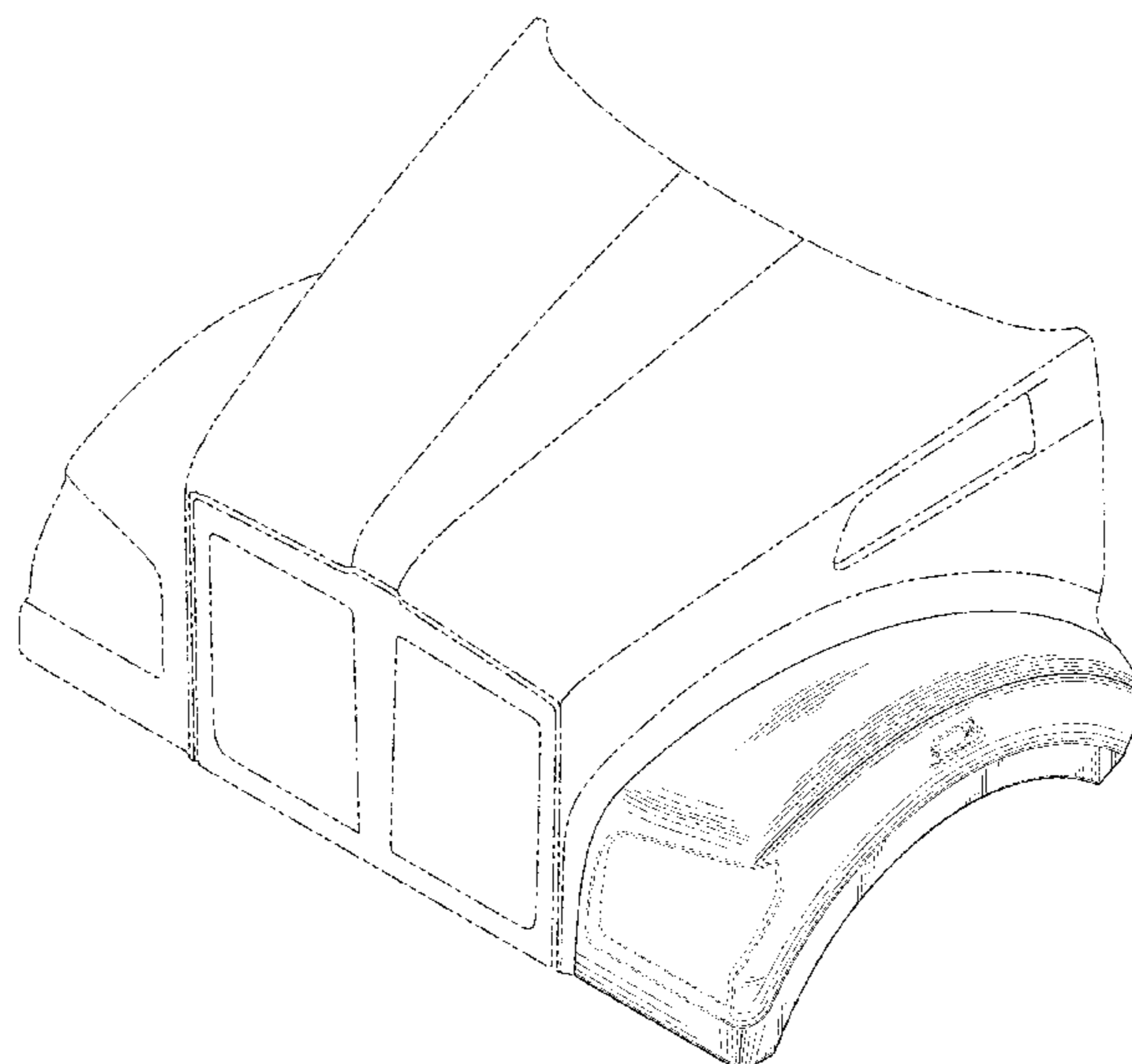

(56)

References Cited

U.S. PATENT DOCUMENTS

D382,239 S 8/1997 Logan et al.
 D382,841 S 8/1997 Norwood et al.
 D382,844 S 8/1997 Norwood et al.
 D395,848 S * 7/1998 Meryman D12/97
 D395,860 S 7/1998 Meryman et al.
 D401,198 S 11/1998 Mueller et al.
 D403,636 S 1/1999 Meryman et al.
 D403,639 S 1/1999 Gale et al.
 D411,494 S 6/1999 Meryman et al.
 D412,689 S 8/1999 Onopa
 D422,251 S 4/2000 Bader et al.
 D431,806 S 10/2000 Damon et al.
 D433,980 S 11/2000 Conway et al.
 D433,981 S * 11/2000 Davis D12/196
 D434,358 S 11/2000 Conway et al.
 D435,816 S 1/2001 Delashaw et al.
 D436,563 S 1/2001 Delashaw et al.
 D443,853 S 6/2001 Barraclough et al.
 D446,175 S 8/2001 Hoyle, Jr.
 D450,277 S 11/2001 Onopa
 D460,023 S * 7/2002 Beigel D12/96
 D465,749 S 11/2002 Beigel
 D466,450 S 12/2002 Maher et al.
 D478,300 S 8/2003 Chiang
 D482,993 S 12/2003 Conway et al.
 D484,077 S 12/2003 Conway et al.
 D488,112 S 4/2004 Satou
 D490,749 S 6/2004 Satou et al.
 D491,858 S 6/2004 Velazco
 D492,921 S 7/2004 Perfetti et al.
 D494,900 S 8/2004 Satou
 D495,633 S 9/2004 Chiang
 D497,581 S 10/2004 Conway et al.
 D502,901 S 3/2005 Delashaw et al.
 D502,904 S 3/2005 Delashaw et al.
 6,883,860 B1 * 4/2005 Budge B62D 33/0612
 296/190.02
 D504,642 S 5/2005 Perfetti et al.
 D511,727 S 11/2005 Shaw et al.
 D512,666 S 12/2005 Chiang
 D514,483 S 2/2006 Chiang
 D517,965 S 3/2006 Metros et al.
 D518,761 S 4/2006 Chiang
 D523,793 S 6/2006 Beigel et al.
 D524,204 S 7/2006 Beigel
 D531,947 S 11/2006 Angelo et al.
 D532,350 S 11/2006 Angelo et al.
 D532,352 S 11/2006 Angelo et al.
 D540,725 S 4/2007 Gunter et al.
 D540,727 S 4/2007 Elliott et al.
 D545,250 S 6/2007 Angelo et al.
 D545,251 S 6/2007 Angelo et al.
 D545,254 S 6/2007 Angelo et al.
 D545,255 S 6/2007 Angelo et al.
 D560,575 S 1/2008 Simons et al.
 D560,582 S 1/2008 Simons et al.
 D560,583 S 1/2008 Simons et al.
 D563,281 S 3/2008 Simons et al.
 D563,849 S 3/2008 Medina et al.
 D563,850 S 3/2008 Rosen et al.
 D563,851 S 3/2008 Rosen et al.
 D563,852 S 3/2008 Rosen et al.
 D563,853 S 3/2008 Rosen et al.
 D564,427 S 3/2008 Beigel et al.
 D566,635 S 4/2008 Rosen et al.
 D571,696 S 6/2008 Rosen et al.
 D578,453 S 10/2008 Raghavendran et al.
 D588,512 S 3/2009 Raghavendran et al.
 D592,574 S 5/2009 Larson
 D597,003 S 7/2009 Yamazaki et al.
 D605,986 S 12/2009 Raghavendran et al.
 D619,941 S 7/2010 Krauss
 D621,754 S 8/2010 Angelo et al.
 D622,188 S 8/2010 Angelo et al.
 D632,234 S 2/2011 Peltola et al.

D634,244 S * 3/2011 Aris D12/96
 D643,352 S 8/2011 Hjorten et al.
 D647,016 S 10/2011 Medina et al.
 D647,832 S 11/2011 Medina et al.
 D651,136 S * 12/2011 Stimel, Jr. D12/96
 D654,401 S 2/2012 Peltola et al.
 D654,417 S 2/2012 Peltola et al.
 D685,294 S 7/2013 Hanson et al.
 D686,122 S 7/2013 Peltola et al.
 D690,242 S 9/2013 Conway et al.
 D690,632 S 10/2013 Peltola et al.
 D699,650 S 2/2014 Peltola et al.
 D699,651 S 2/2014 Peltola et al.
 D702,609 S 4/2014 Hovind et al.
 D702,615 S 4/2014 Conway et al.
 D706,690 S 6/2014 Peltola et al.
 D707,160 S 6/2014 Peltola et al.
 D707,161 S 6/2014 Peltola et al.
 D707,163 S 6/2014 Peltola et al.
 D708,104 S 7/2014 Conway et al.
 D708,553 S 7/2014 Conway et al.
 D708,985 S 7/2014 Peltola et al.
 D708,986 S 7/2014 Conway et al.
 D708,989 S 7/2014 Peltola et al.
 D708,990 S 7/2014 Conway et al.
 D708,999 S 7/2014 Conway et al.
 D709,000 S 7/2014 Peltola et al.
 D709,001 S 7/2014 Conway et al.
 D709,406 S 7/2014 Conway et al.
 D709,407 S 7/2014 Conway et al.
 D709,408 S 7/2014 Peltola et al.
 D709,410 S 7/2014 Conway et al.
 D709,411 S 7/2014 Peltola et al.
 D709,421 S 7/2014 Conway et al.
 D709,422 S 7/2014 Peltola et al.
 D709,423 S 7/2014 Peltola et al.
 D709,424 S 7/2014 Conway et al.
 D709,425 S 7/2014 Conway et al.
 D710,765 S 8/2014 Conway et al.
 D714,195 S 9/2014 Conway et al.
 D722,934 S 2/2015 Conway et al.
 8,960,769 B2 * 2/2015 He B62D 35/001
 296/180.2
 D729,709 S 5/2015 Conway et al.
 D746,200 S 12/2015 Leetz
 D756,855 S 5/2016 Leetz et al.
 D770,335 S 11/2016 Walterscheid et al.
 D782,381 S 3/2017 Conway et al.
 D799,380 S * 10/2017 Cosme D12/96
 D805,981 S 12/2017 Conway et al.
 D842,182 S * 3/2019 Lee D12/190
 2013/0025954 A1 1/2013 Miller et al.

OTHER PUBLICATIONS

“AeroCab,” Kenworth Truck Company, Kirkland, Washington, as early as 1995, 3-page brochure.
 “C500B,” Kenworth Truck Company, Kirkland, Washington, as early as 1990, 4-page brochure.
 “Class Pays, Medium Duty,” Peterbilt Motors Company, Denton, Texas, Sep. 2000, 12-page brochure.
 “Class Pays, Truck Models,” Peterbilt Motors Company, Denton, Texas, Mar. 2005, 24-page brochure.
 “Class Pays,” Peterbilt Motors Company, Denton, Texas, Nov. 1998, 10-page brochure.
 “Class Pays,” Peterbilt Motors Company, Denton, Texas, Sep. 1997, 10-page brochure.
 “Class Pays, Construction Trucks,” Peterbilt Motors Company, Denton, Texas, Nov. 2003, 16-page brochure.
 “Kenworth Truck Models,” Kenworth Truck Company, Kirkland, Washington, 2010, 16-page brochure.
 “Model 330,” Peterbilt Motors Company, Denton, Texas, Oct. 1997, 3-page brochure.
 “Model 357 Heavy Haul,” Peterbilt Motors Company, Denton, Texas, Mar. 2005, 2-page brochure.

(56)

References Cited

OTHER PUBLICATIONS

- “Model 357 Standard Specifications,” Peterbilt Motors Company, Newark, California, Sep. 1986, 6-page brochure.
- “Model 357, New Sloped Hood,” Peterbilt Motors Company, Denton, Texas, May 2002, 2-page brochure.
- “Model 357,” Peterbilt Motors Company, Denton, Texas, May 1994, 3-page brochure.
- “Model 357-115,” Peterbilt Motors Company, Denton, Texas, Mar. 2005, 2-page brochure.
- “Model 375 Standard Specifications,” Peterbilt Motors Company, Newark, California, Sep. 1986, 6-page brochure.
- “Model 377A/E,” Peterbilt Motors Company, Denton, Texas, Aug. 1997, 2-page brochure.
- “Model 377A/E,” Peterbilt Motors Company, Denton, Texas, Jan. 1995, 6-page brochure.
- “Model 378,” Peterbilt Motors Company, Denton, Texas, Mar. 1998, 3-page brochure.
- “Model 379,” Peterbilt Motors Company, Denton, Texas, Apr. 2005, 2-page brochure.
- “Model 379,” Peterbilt Motors Company, Denton, Texas, Mar. 1996, 5-page brochure.
- “Model 385,” Peterbilt Motors Company, Denton, Texas, Oct. 1996, 5-page brochure.
- “Model 387,” Peterbilt Motors Company, Denton, Texas, Oct. 2002, 2-page brochure.
- “Rest with Class,” Peterbilt Motors Company, Newark, California, Apr. 1978, 4-page brochure.
- “T170 Class 5,” Kenworth Truck Company, Kirkland, Washington, 2008, 4-page brochure.
- “T2000,” Kenworth Truck Company, Kirkland, Washington, 1999, 20-page brochure.
- “T2000,” Kenworth Truck Company, Kirkland, Washington, 2002, 20-page brochure.
- “T2000,” Kenworth Truck Company, Kirkland, Washington, 2005, 20-page brochure.
- “T270 Class 6 and T370 Class 7,” Kenworth Truck Company, Kirkland, Washington, 2008, 6-page brochure.
- “T270 Class 6 and T370 Class 7,” Kenworth Truck Company, Kirkland, Washington, 2009, 6-page brochure.
- “T270 Class 6 and T370 Class 7 Hybrid,” Kenworth Truck Company, Kirkland, Washington, 2009, 6-page brochure.
- “T300,” Kenworth Truck Company, Kirkland, Washington, 1994, 4-page brochure.
- “T300,” Kenworth Truck Company, Kirkland, Washington, 2001, 16-page brochure.
- “T300,” Kenworth Truck Company, Kirkland, Washington, 2005, 16-page brochure.
- “T680,” Kenworth Truck Company, Kirkland, Washington, 2013, 34-page brochure.
- “T680,” Kenworth Truck Company, Kirkland, Washington, 2016, 34-page brochure.
- “T880,” Kenworth Truck Company, Kirkland, Washington, 2017, 32-page brochure.
- “Model 579,” Peterbilt Motors Company, Denton, Texas, 2013, 13-page brochure.
- “Model 587,” Peterbilt Motors Company, Denton, Texas, 2011, 4-page brochure.
- “Medium-Duty,” Peterbilt Motors Company, Denton, Texas, 2013, 9-page brochure.
- “On-Highway,” Peterbilt Motors Company, Denton, Texas, 2013, 13-page brochure.
- “Vocational,” Peterbilt Motors Company, Denton, Texas, 2013, 11-page brochure.
- “T440,” Kenworth Truck Company, Kirkland, Washington, 2010, 2-page brochure.
- “T440,” Kenworth Truck Company, Kirkland, Washington, 2010, 6-page brochure.
- “T470,” Kenworth Truck Company, Kirkland, Washington, 2010, 6-page brochure.
- “T470H,” Kenworth Truck Company, Kirkland, Washington, 2009, 2-page brochure.
- “T600,” Kenworth Truck Company, Kirkland, Washington, 1996, 7-page brochure.
- “T600,” Kenworth Truck Company, Kirkland, Washington, 2002, 28-page brochure.
- “T600,” Kenworth Truck Company, Kirkland, Washington, 2005, 24-page brochure.
- “T600A,” Kenworth Truck Company, Kirkland, Washington, 1985, 10-page brochure.
- “T660,” Kenworth Truck Company, Kirkland, Washington, 2007, 36-page brochure.
- “T660,” Kenworth Truck Company, Kirkland, Washington, 2009, 36-page brochure.
- “T700,” Kenworth Truck Company, Kirkland, Washington, 2010, 6-page brochure.
- “T800,” Kenworth Truck Company, Kirkland, Washington, 1996, 7-page brochure.
- “T800,” Kenworth Truck Company, Kirkland, Washington, 2002, 32-page brochure.
- “T800,” Kenworth Truck Company, Kirkland, Washington, 2003, 32-page brochure.
- “T800,” Kenworth Truck Company, Kirkland, Washington, 2005, 28-page brochure.
- “T800,” Kenworth Truck Company, Kirkland, Washington, 2009, 28-page brochure.
- “T800B,” Kenworth Truck Company, Kirkland, Washington, 1993, 8-page brochure.
- “The Working Class,” Peterbilt Motors Company, Newark, California, Sep. 1976, 6-page brochure.
- “The World’s Best,” Kenworth Truck Company, Kirkland, Washington, 1992, 12-page brochure.
- “Unibilt™ Cab Sleeper System,” Peterbilt Motors Company, Denton Texas, Aug. 1994, 6-page brochure.
- “W900,” Kenworth Truck Company, Kirkland, Washington, 1996, 7-page brochure.
- “W900,” Kenworth Truck Company, Kirkland, Washington, 2002, 32-page brochure.
- “W900,” Kenworth Truck Company, Kirkland, Washington, 2005, 28-page brochure.
- “W900,” Kenworth Truck Company, Kirkland, Washington, 2009, 28-page brochure.
- “W900L Aero Cab,” Kenworth Truck Company, Kirkland, Washington, 1994, 2-page brochure.

* cited by examiner

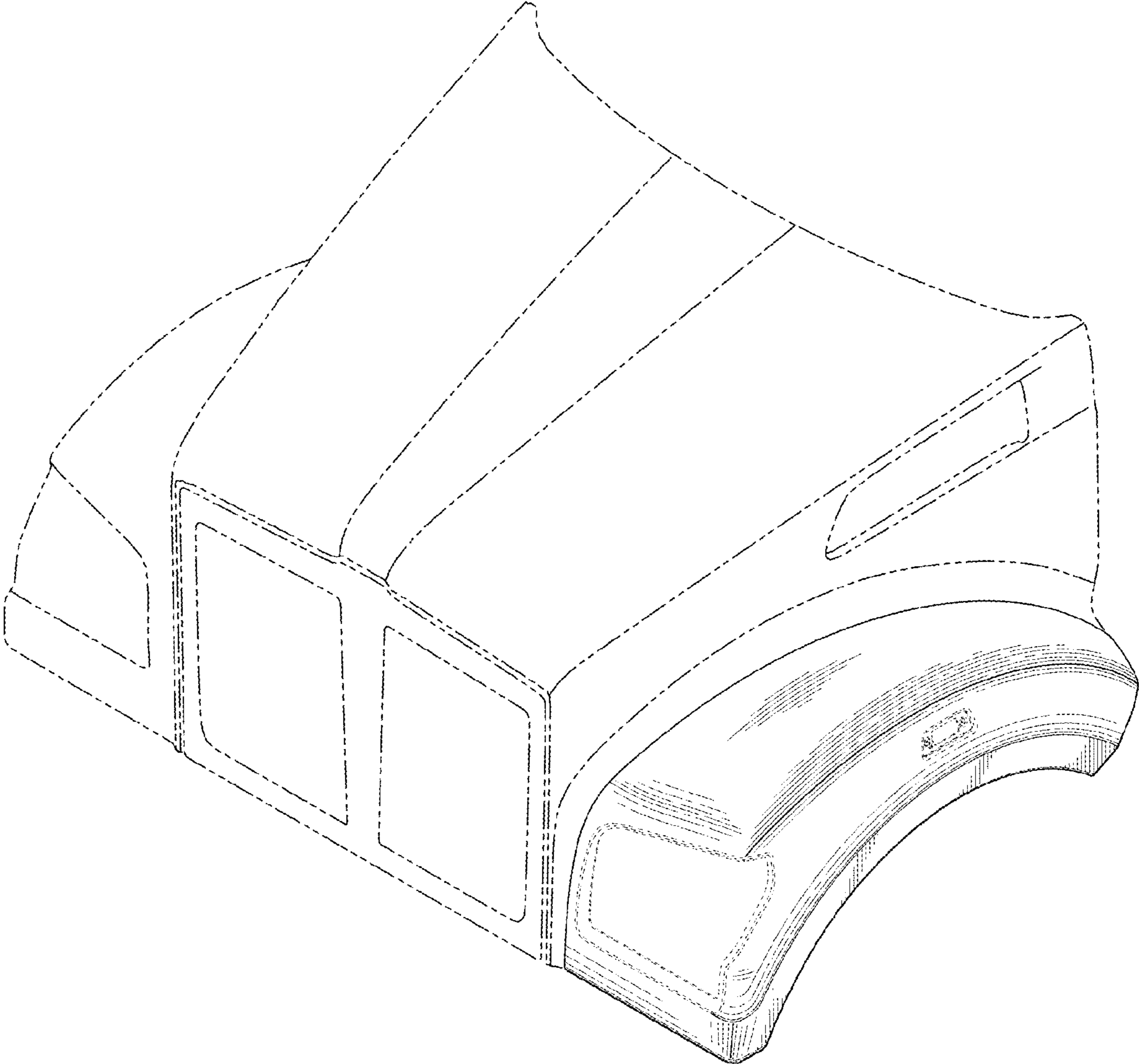

Fig. 1.

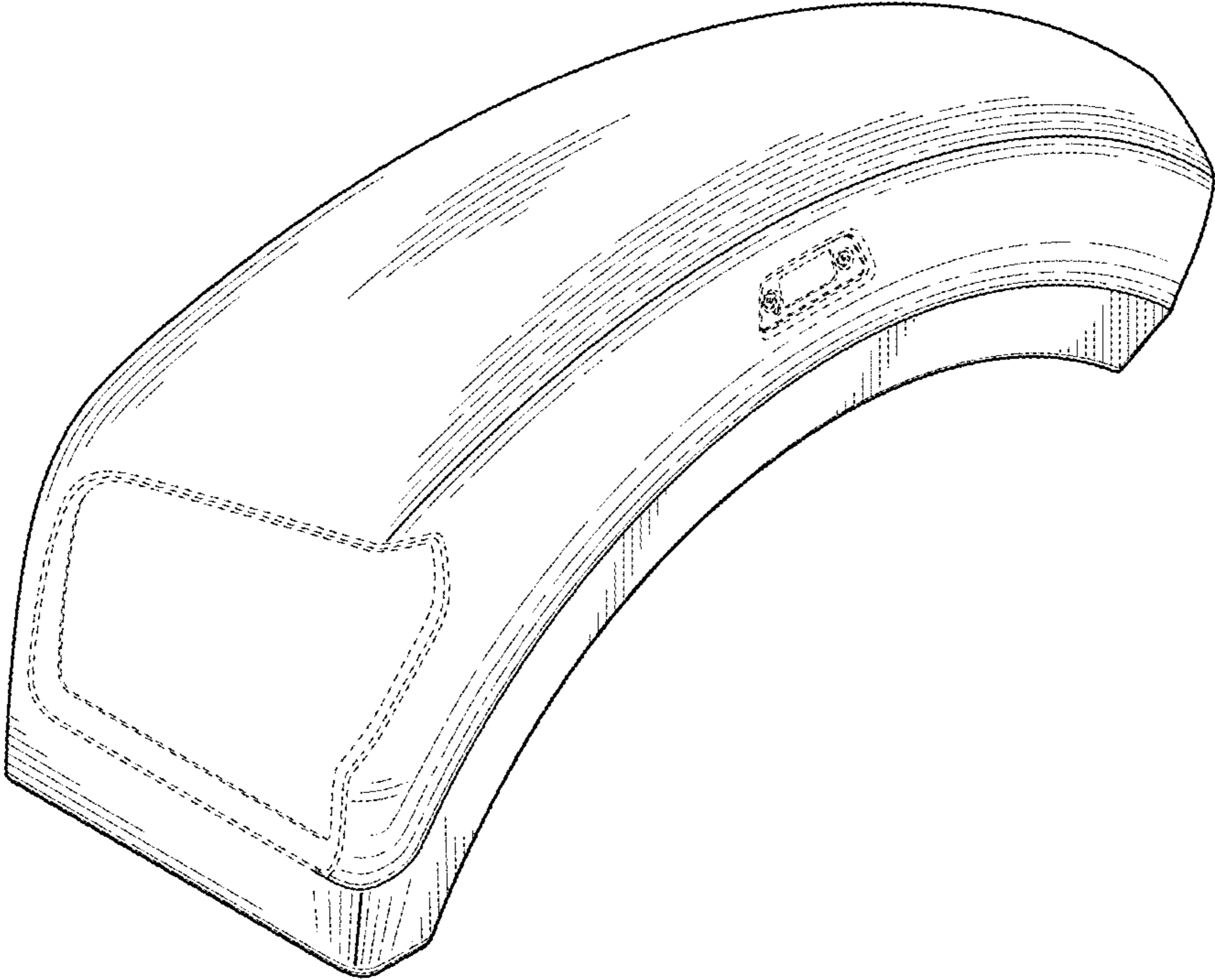

Fig. 2.

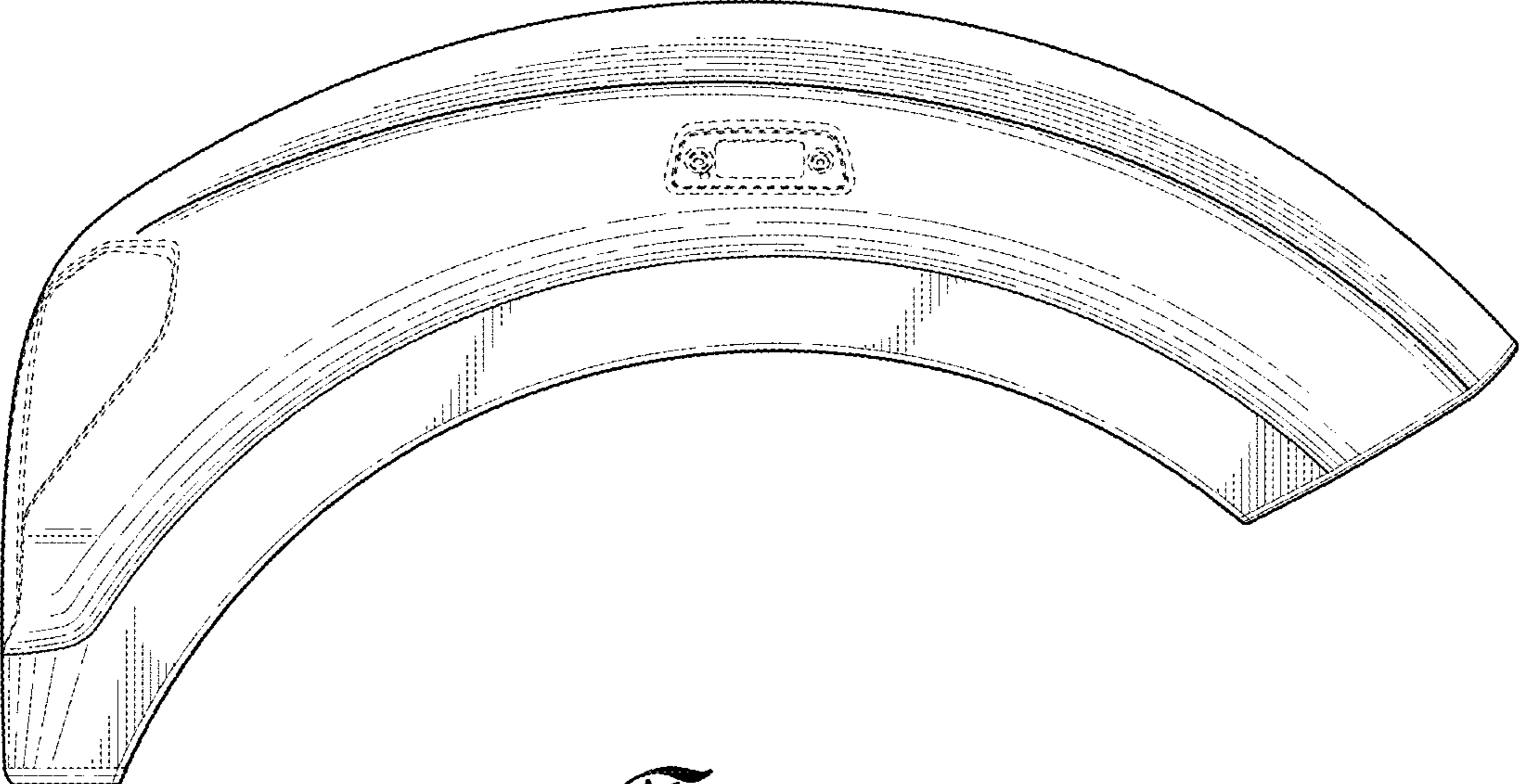

Fig. 3.

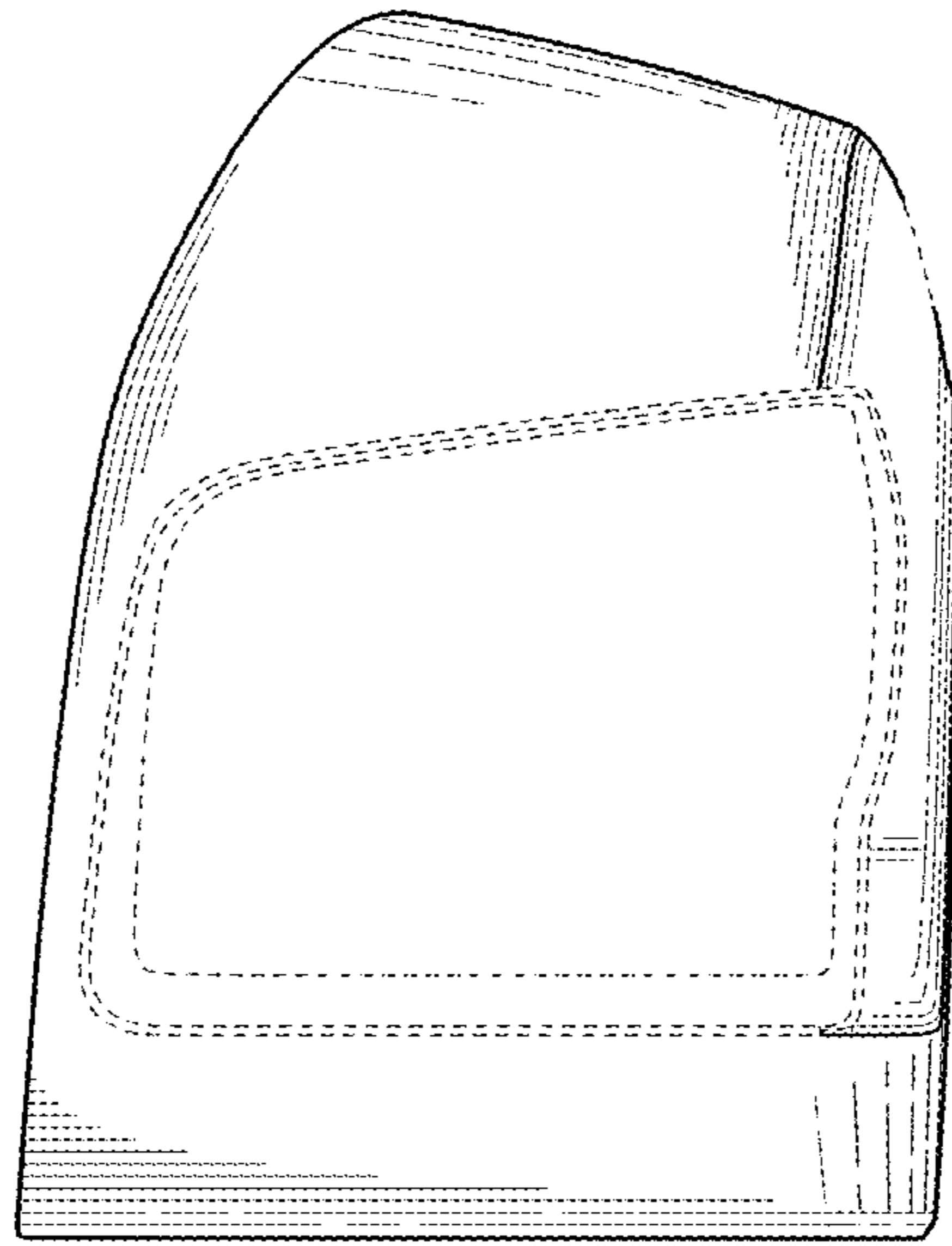

Fig. 4.

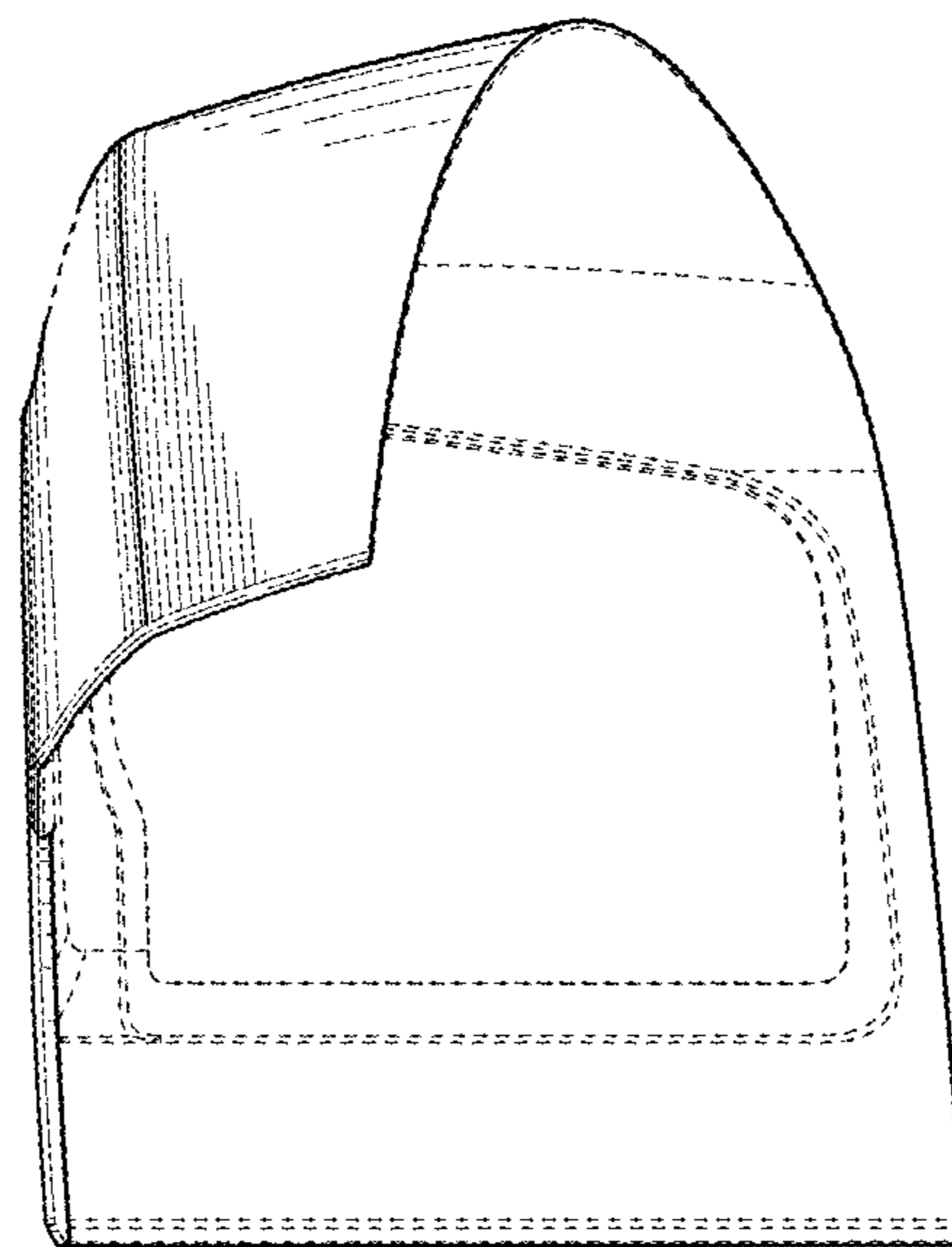

Fig. 5.



Fig. 6.

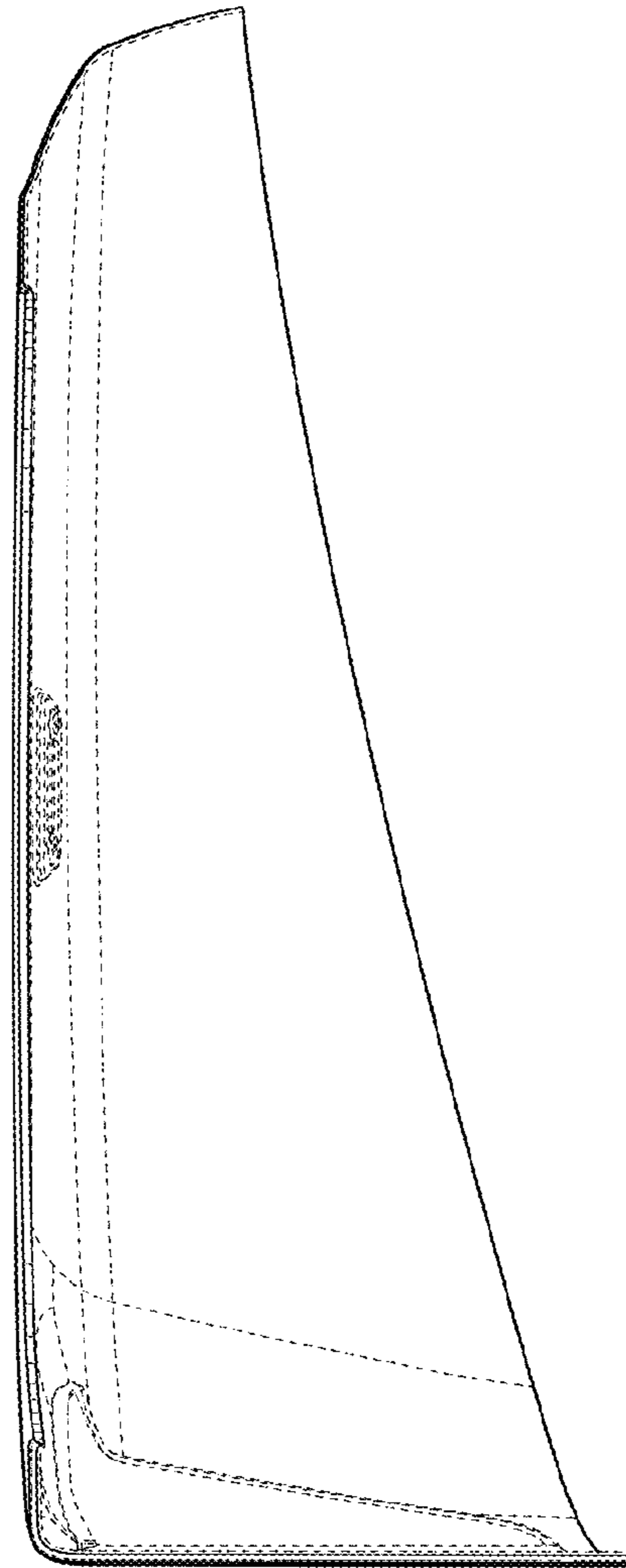

Fig. 7.

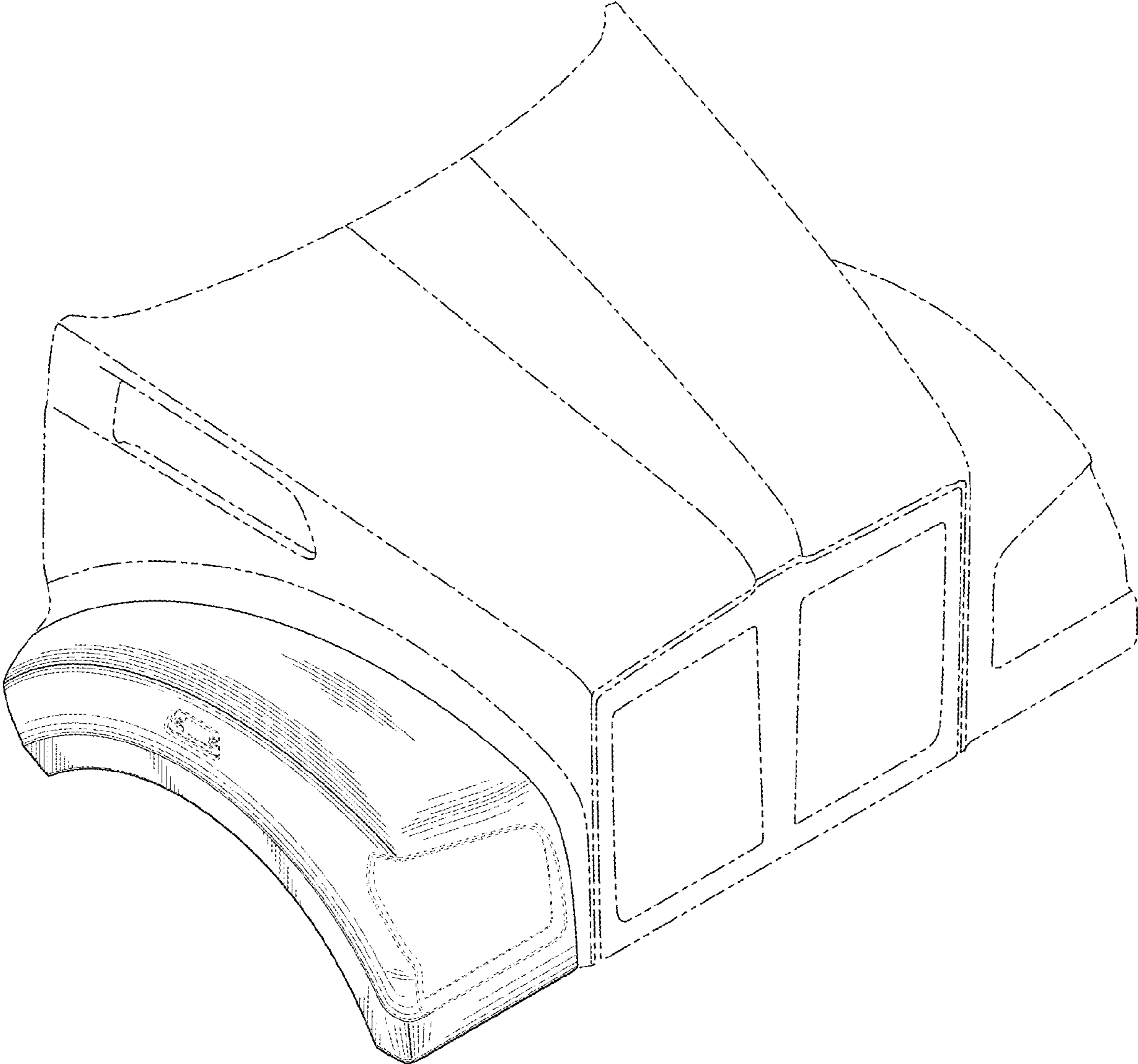

Fig. 8.

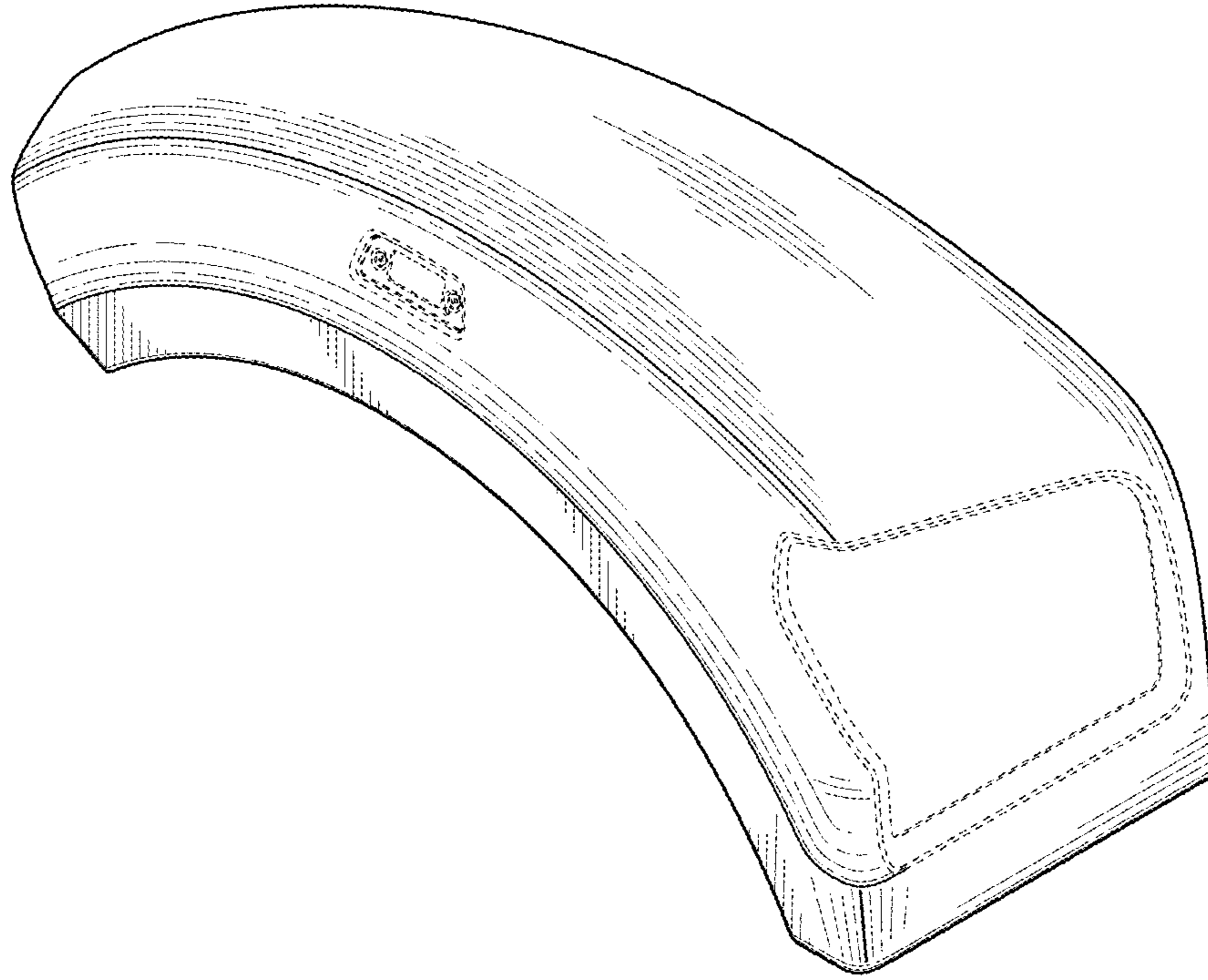

Fig. 9.

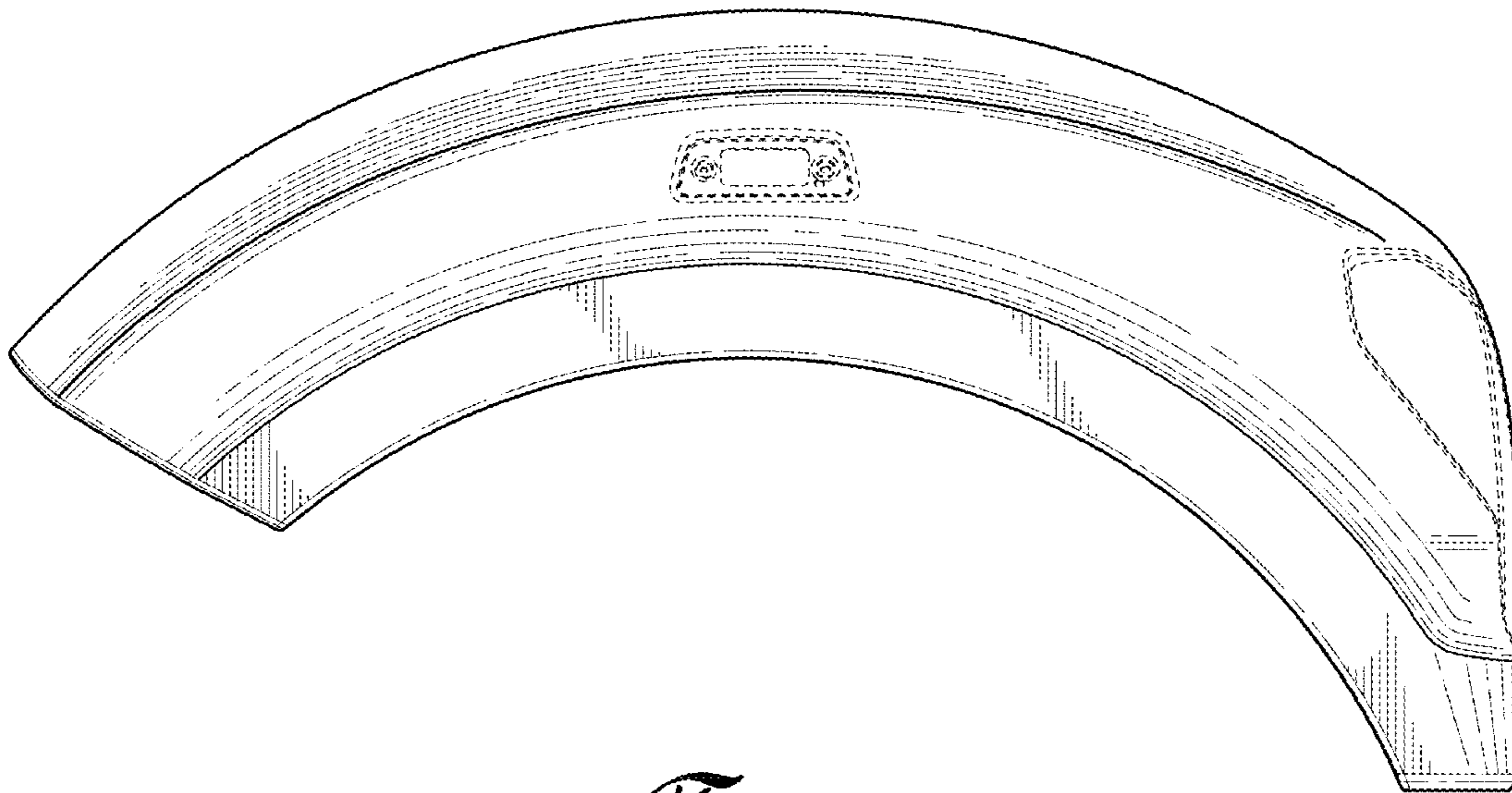

Fig. 10.

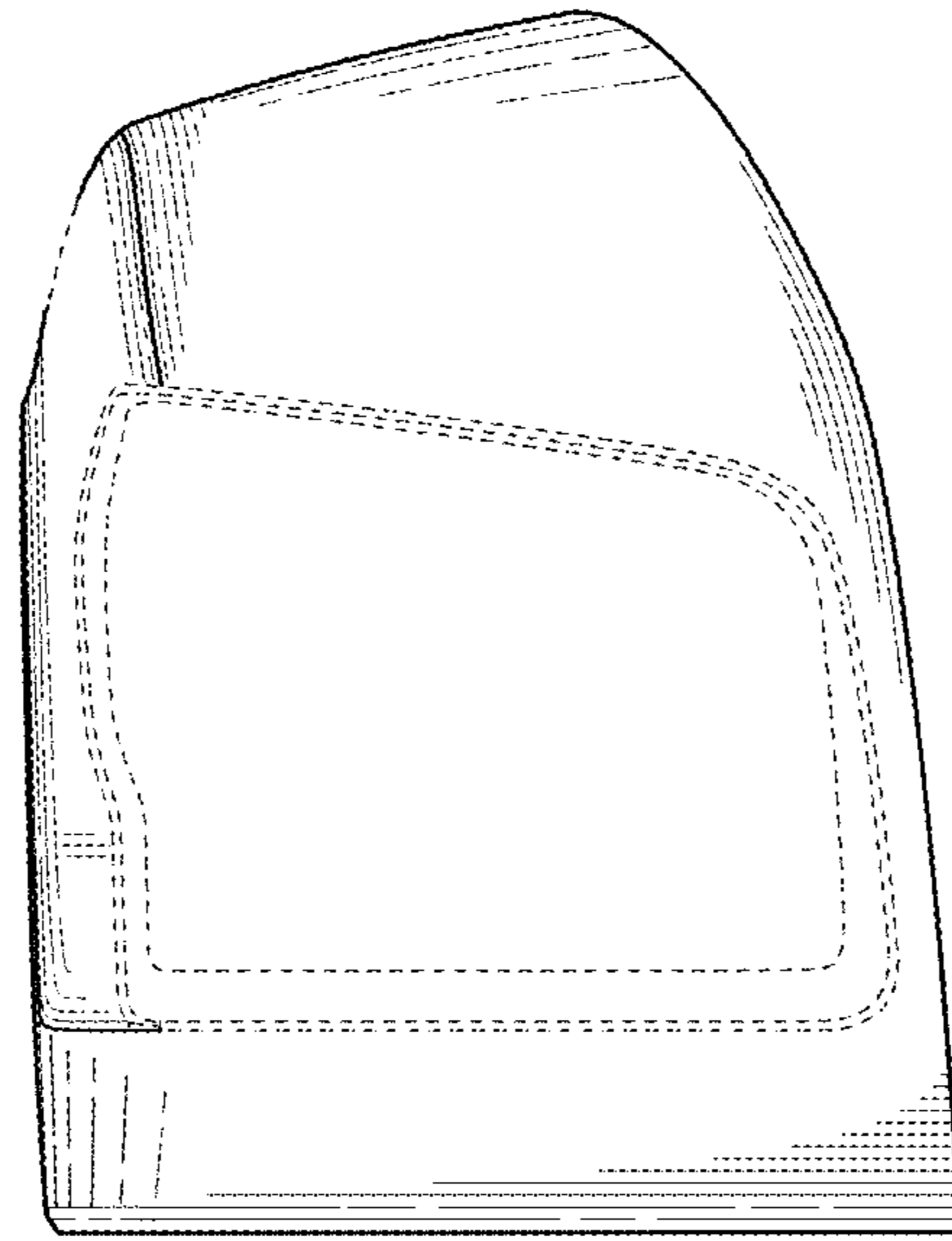

Fig. 11.

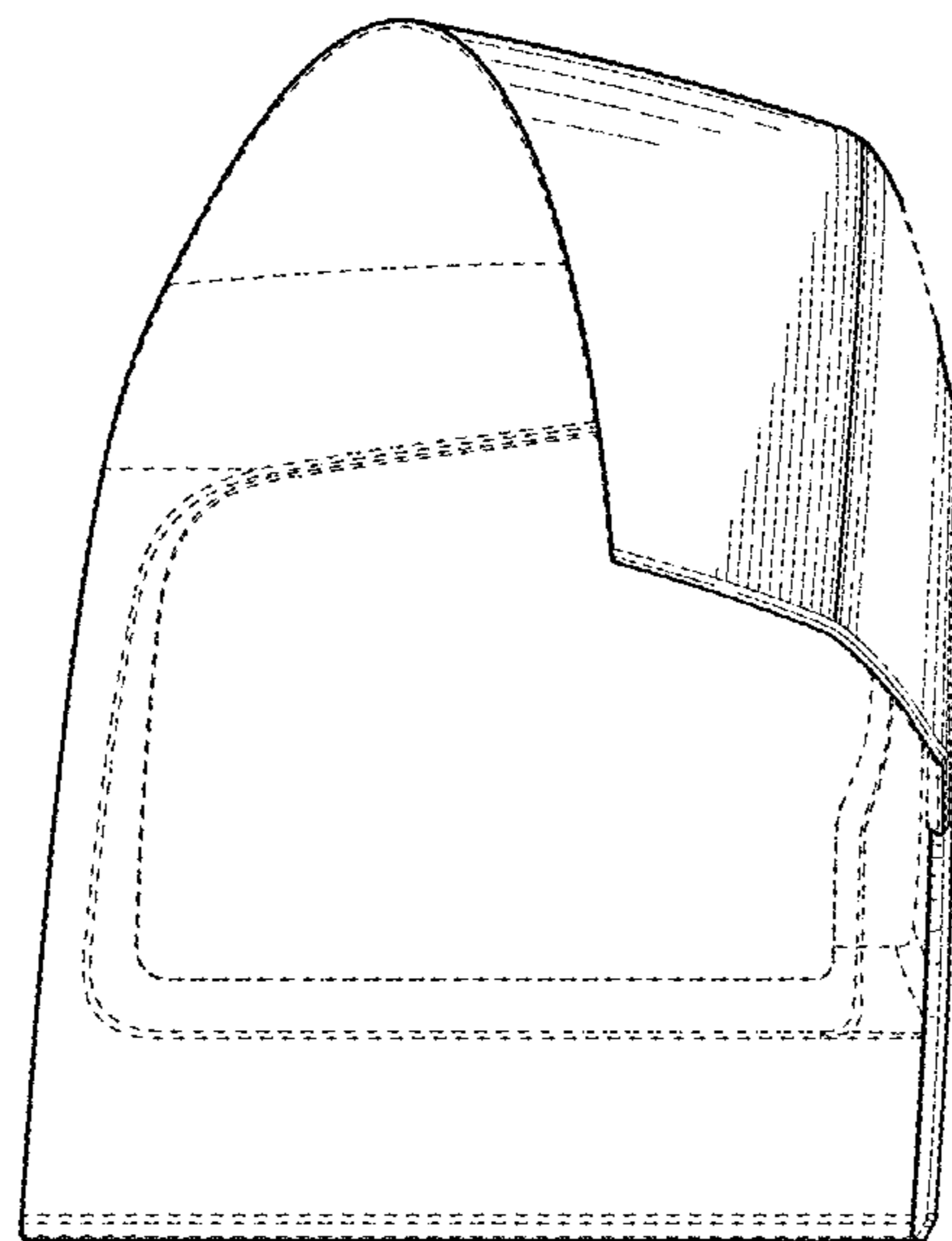

Fig. 12.

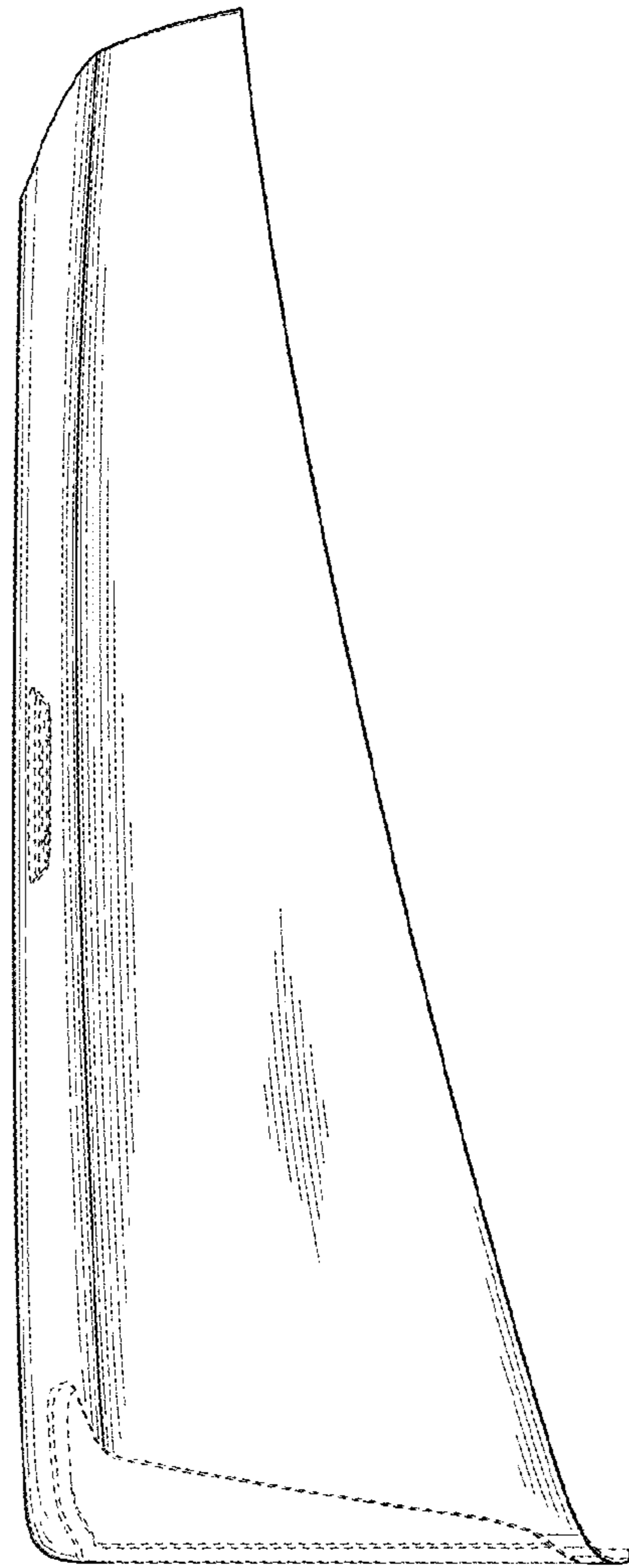

Fig. 13.

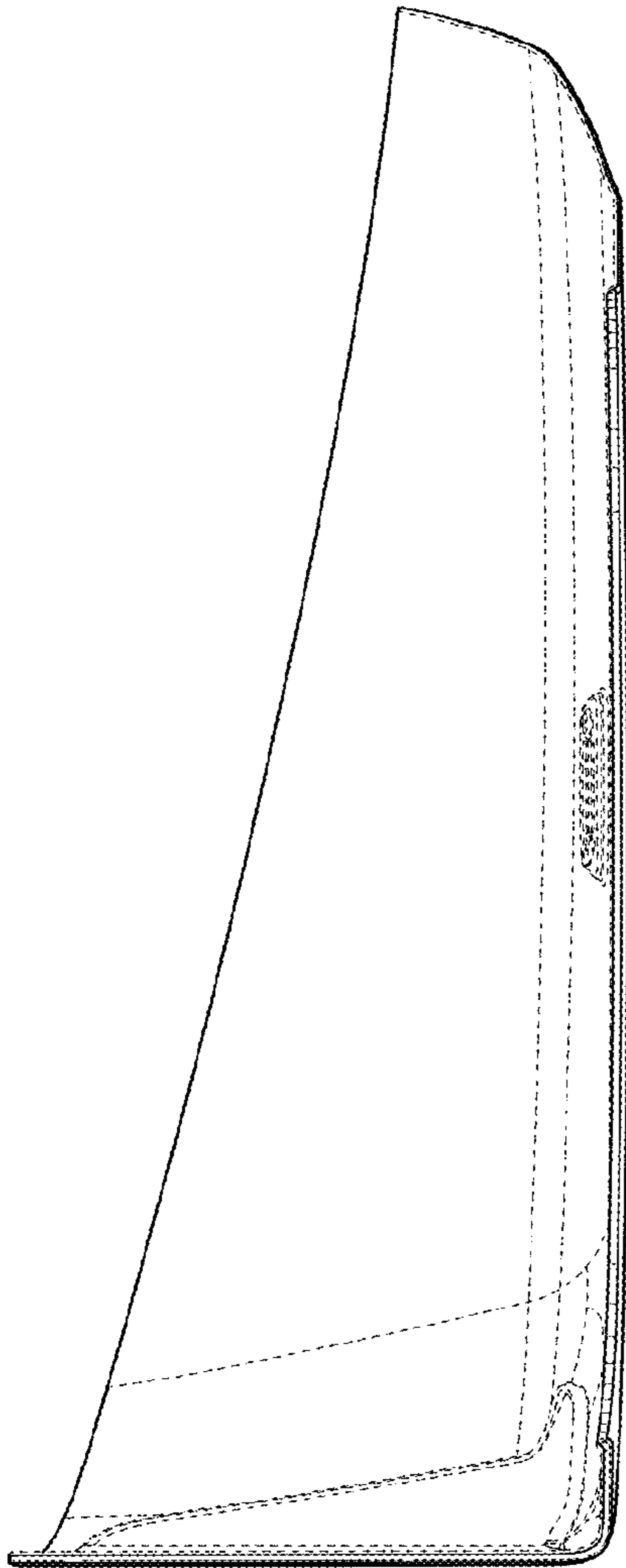

Fig. 14.