



US00D875582S

(12) **United States Design Patent**  
**Bivans et al.**

(10) **Patent No.:** **US D875,582 S**

(45) **Date of Patent:** **\*\* Feb. 18, 2020**

(54) **INLINE PRESSURE SENSOR AND ELECTRICAL CONNECTOR**

(71) Applicants: **Baxter International Inc.**, Deerfield, IL (US); **Baxter Healthcare SA**, Glattpark (Opfikon) (CH)

(72) Inventors: **Matthew Alan Bivans**, Barrington, IL (US); **William R. Griswold**, Lake Geneva, WI (US); **Karl Hans Cazzini**, Lindenhurst, IL (US); **Jonathan Toback**, Chicago, IL (US); **Keerthika Lakshmi Niharika Chinthapalli**, Round Lake, IL (US); **Julia Radchenko**, Buffalo Grove, IL (US); **Sarah Louise Corbin**, Hawthorn Woods, IL (US); **Andrea Frances Ritchie**, Alameda, CA (US); **Timothy Brian Sanchez**, Chicago, IL (US); **Ulf Quensel**, Ystad (SE); **Jonathan A. Handler**, Northbrook, IL (US)

(73) Assignees: **BAXTER INTERNATIONAL INC.**, Deerfield, IL (US); **BAXTER HEALTHCARE SA**, Glattpark (Opfikon) (CH)

(\*\*) Term: **15 Years**

(21) Appl. No.: **29/692,701**

(22) Filed: **May 28, 2019**

**Related U.S. Application Data**

(62) Division of application No. 29/647,517, filed on May 14, 2018.

(51) **LOC (12) Cl.** ..... **10-04**

(52) **U.S. Cl.**  
USPC ..... **D10/85; D24/186**

(58) **Field of Classification Search**  
USPC ..... **D10/85; D24/186**

CPC . G01L 7/02; G01L 7/022; G01L 7/024; G01L 7/026; G01L 7/04; G01L 7/08; G01L 9/00; G01L 9/0001; G01L 9/0026; G01L 9/0033; G01L 9/0041; G01L 9/0042; G01L 9/0044; G01L 2019/0053; G01L 19/14; G01L 19/0092; G01L 19/141; G01L 19/142; G01L 19/143; G01L 19/144; G01L 19/145; G01L 19/146; G01L 19/147; G01L 19/148; G01L 19/149; A61B 90/06; A61B 2090/064

See application file for complete search history.

(56) **References Cited**

**U.S. PATENT DOCUMENTS**

D840,357 S \* 2/2019 Zhao ..... D24/186

\* cited by examiner

*Primary Examiner* — Antoine Duval Davis

(74) *Attorney, Agent, or Firm* — K&L Gates LLP

(57) **CLAIM**

The ornamental design for an inline pressure sensor and electrical connector, as shown and described herein.

**DESCRIPTION**

FIG. 1 illustrates a perspective view of an inline pressure sensor embodying the invention.

FIG. 2 illustrates a front view of the inline pressure sensor shown in FIG. 1.

FIG. 3 illustrates a rear view of the inline pressure sensor shown in FIG. 1.

FIG. 4 illustrates a right side view of the inline pressure sensor shown in FIG. 1.

FIG. 5 illustrates a left side view of the inline pressure sensor shown in FIG. 1.

FIG. 6 illustrates a top view of the inline pressure sensor shown in FIG. 1; and,

FIG. 7 illustrates a bottom view of the inline pressure sensor shown in FIG. 1.

**1 Claim, 5 Drawing Sheets**

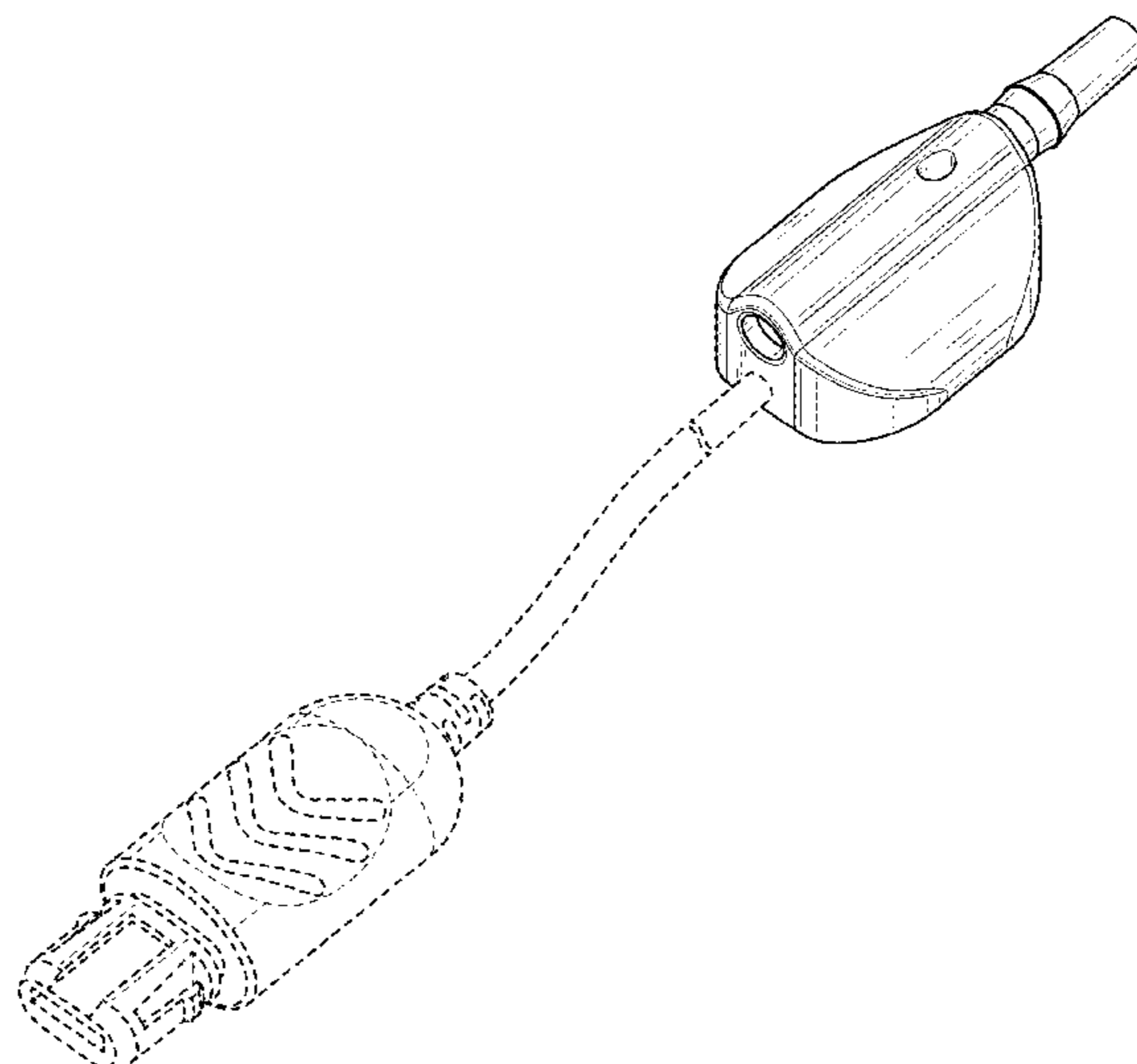

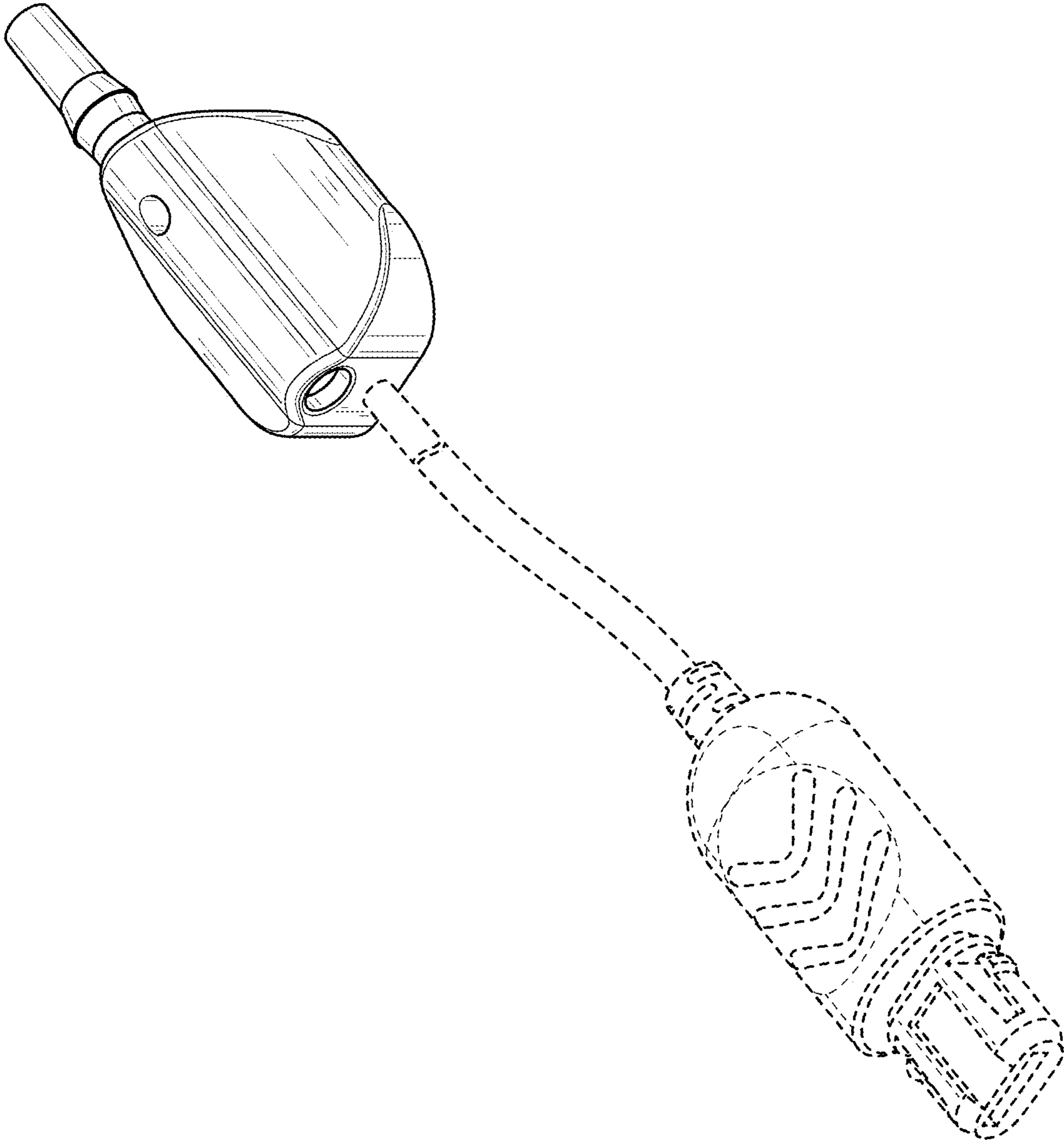

FIG. 1

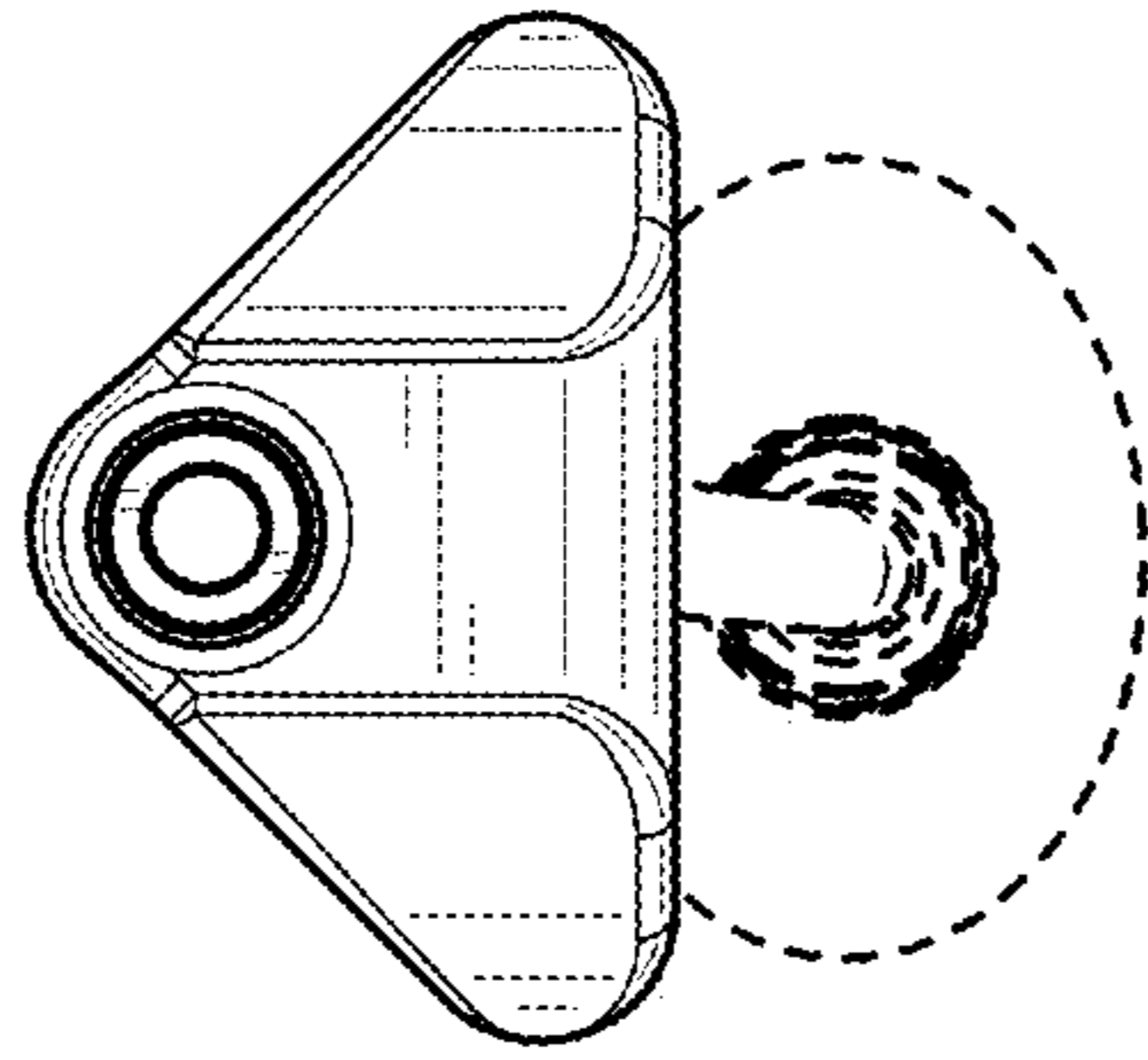

FIG. 3

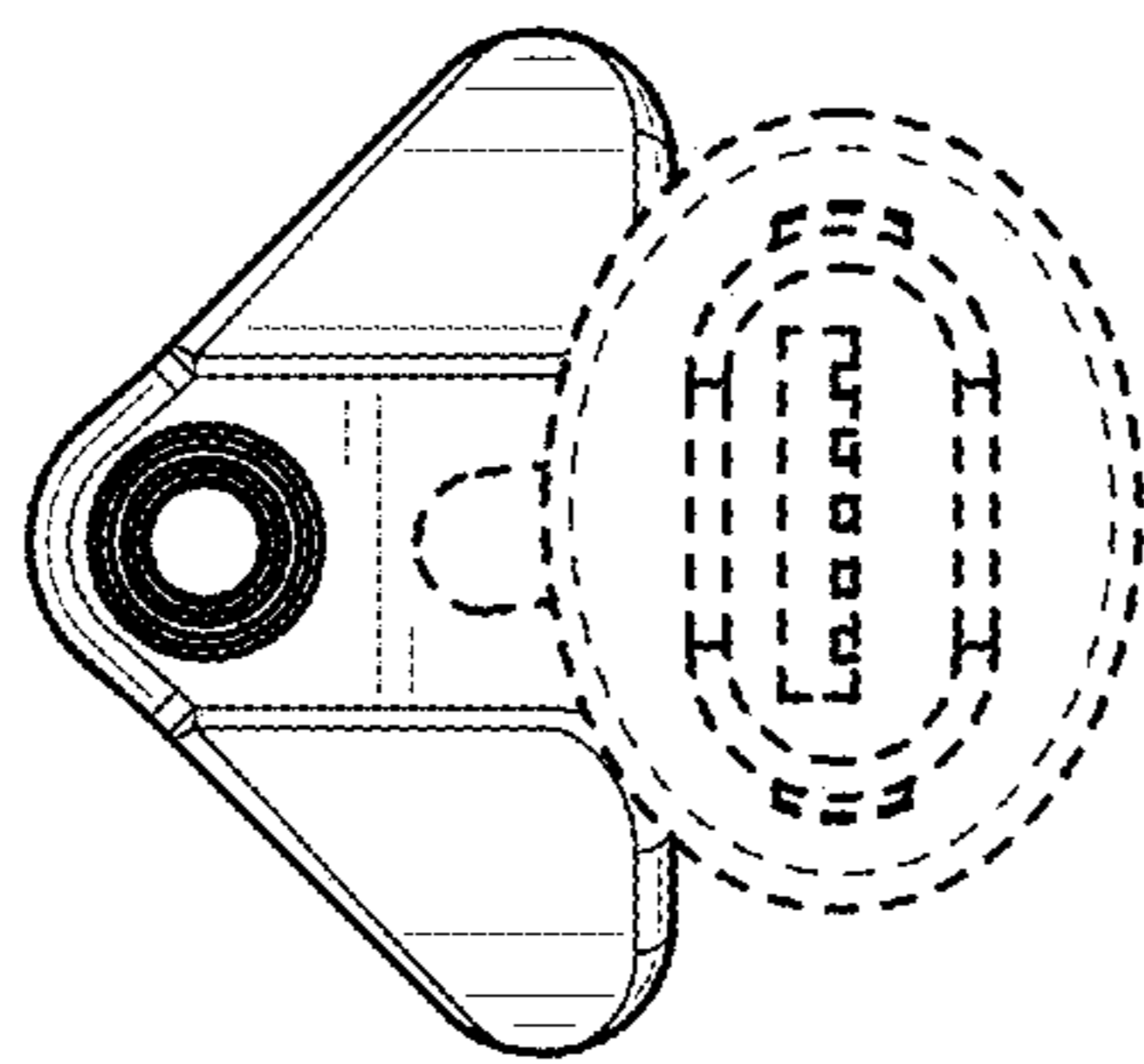

FIG. 2

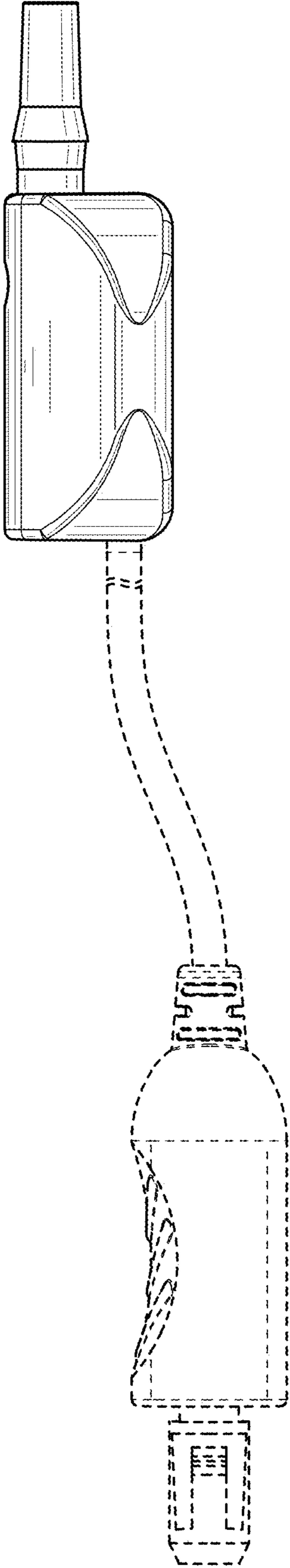

FIG. 4

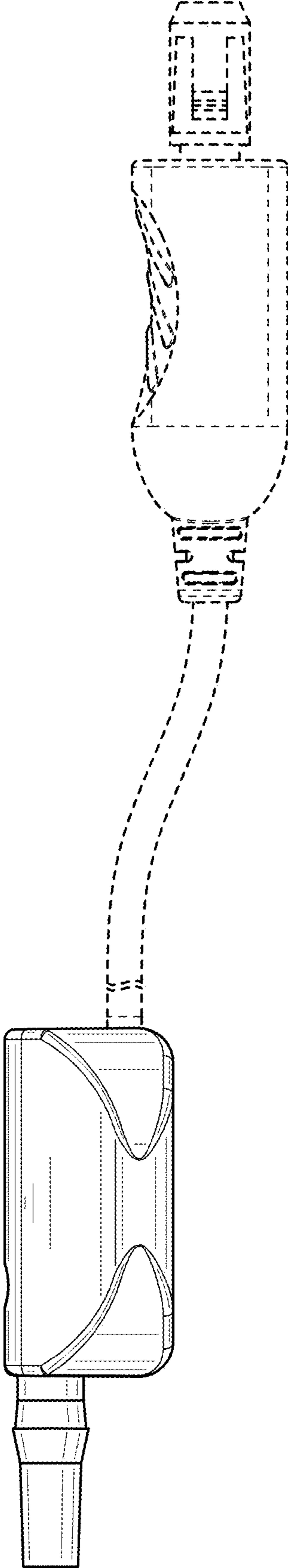

FIG. 5

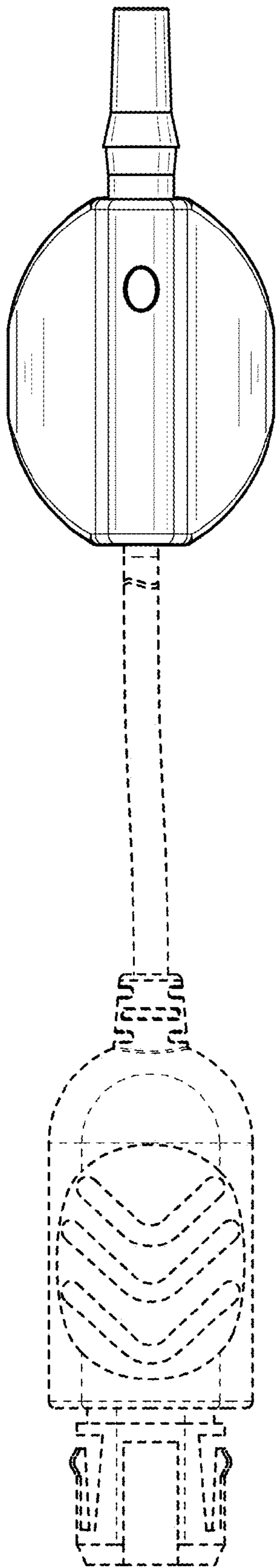

FIG. 6

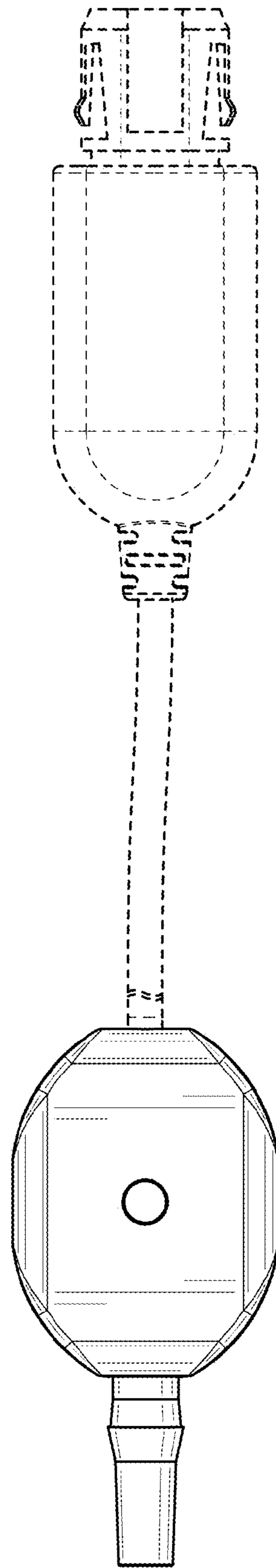

FIG. 7