



US00D875445S

(12) **United States Design Patent** (10) **Patent No.:** **US D875,445 S**
Wilfer (45) **Date of Patent:** **** *Feb. 18, 2020**

(54) **MULTIPLE GUITAR STAND**

(74) *Attorney, Agent, or Firm* — Scarinci Hollenbeck, LLC; Libby Babu Verghese

(71) Applicant: **Warwick GmbH & Co. Music Equipment KG**, Markneukirchen (DE)

(57) **CLAIM**

(72) Inventor: **Hans-Peter Wilfer**, Markneukirchen (DE)

The ornamental design for a multiple guitar stand, as shown and described.

(73) Assignee: **WARWICK GMBH & CO. MUSIC EQUIPMENT KG**, Markneukirchen (DE)

DESCRIPTION

(*) Notice: This patent is subject to a terminal disclaimer.

(**) Term: **15 Years**

FIG. 1 is a perspective view of a multiple guitar stand in the extended position;
FIG. 2 is a left-side view of a multiple guitar stand in the extended position;
FIG. 3 is a right-side view of a multiple guitar stand in the extended position;
FIG. 4 is a top view of a multiple guitar stand in the extended position;
FIG. 5 is a back view of a multiple guitar stand in the extended position;
FIG. 6 is a front view of a multiple guitar stand in the extended position;
FIG. 7 is a bottom view of a multiple guitar stand in the extended position;
FIG. 8 is a perspective view of a multiple guitar stand in the retracted position;
FIG. 9 is a left-view of a multiple guitar stand in the retracted position;
FIG. 10 is a right-view of a multiple guitar stand in the retracted position;
FIG. 11 is a top view of a multiple guitar stand in the retracted position;
FIG. 12 is a back view of a multiple guitar stand in the retracted position;
FIG. 13 is a front view of a multiple guitar stand in the retracted position; and,
FIG. 14 is a bottom view of a multiple guitar stand in the retracted position.

(21) Appl. No.: **29/654,648**

(22) Filed: **Jun. 26, 2018**

(30) **Foreign Application Priority Data**

Jan. 19, 2018 (EM) 004672426

(51) **LOC (12) Cl.** **06-06**

(52) **U.S. Cl.**
USPC **D6/682**

(58) **Field of Classification Search**
USPC D6/672-673, 678, 680, 682, 682.3;
D17/9, 20; D14/229, 447
CPC A47F 7/00; A47F 7/0021; A47F 7/0042;
A47B 23/004; A47B 19/002; G01G 5/00
See application file for complete search history.

(56) **References Cited**

U.S. PATENT DOCUMENTS

D44,078 S * 5/1913 Treadway 211/65
2,058,184 A * 10/1936 Sherrard G10G 5/00
211/20
D162,207 S * 2/1951 Mettenleiter 211/64
(Continued)

The elements shown in broken lines do not form any part of the claimed design. The break lines shown in FIGS. 1, 4, 5, 6, 7, 8, 11, 12, 13 and 14 are not part of the claimed design and represent that no particular length is claimed.

Primary Examiner — Kelley A Donnelly

1 Claim, 14 Drawing Sheets

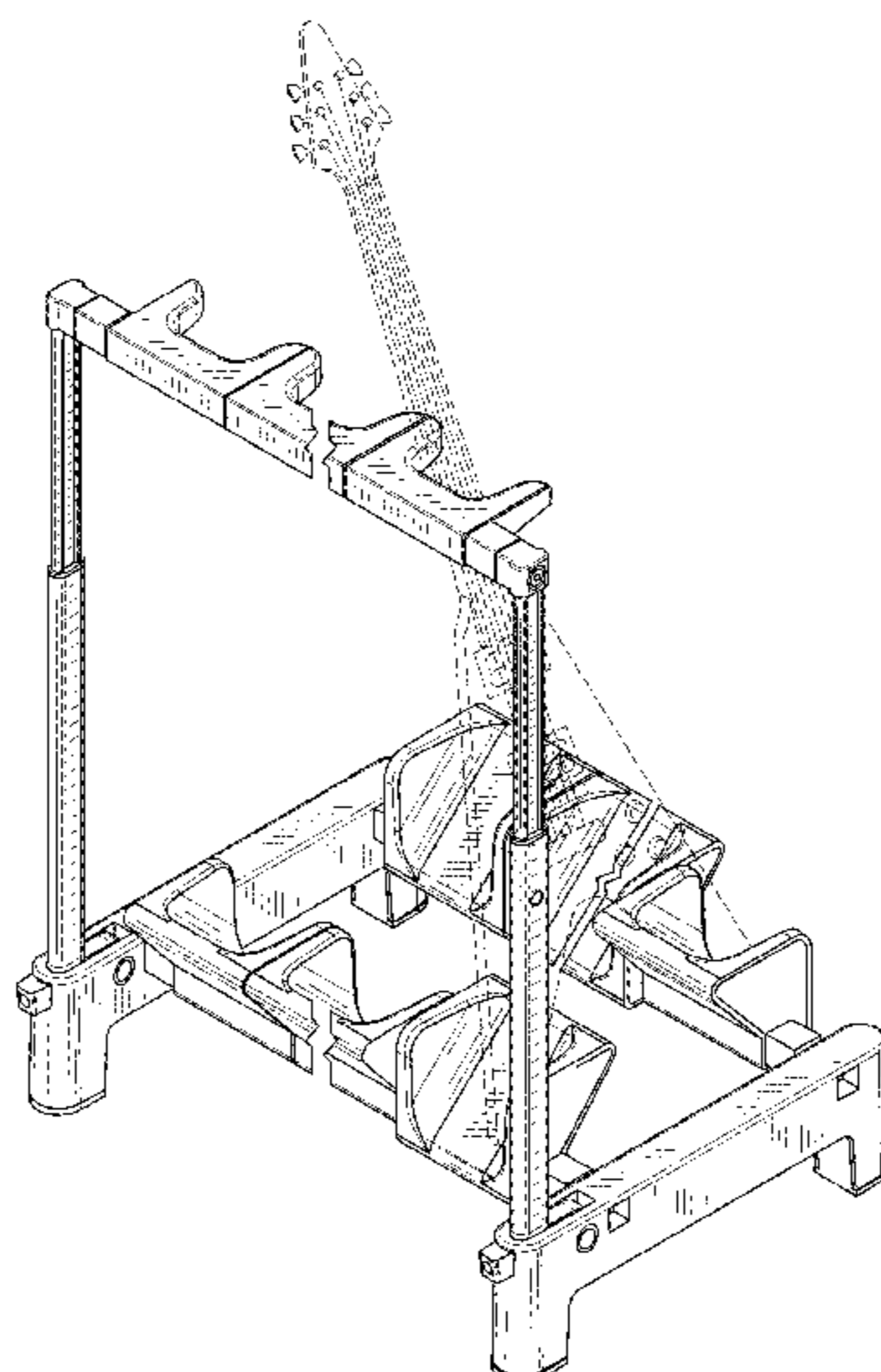

(56)

References Cited

U.S. PATENT DOCUMENTS

3,550,786 A * 12/1970 Brown A47F 5/12
 211/189
 D278,670 S * 5/1985 Schoenig D6/681.1
 D288,509 S * 3/1987 van de Oudeweetering
 D6/682
 D295,814 S * 5/1988 Chang D6/682
 D361,012 S * 8/1995 Dardashti D6/407
 D361,917 S * 9/1995 Dardashti D6/407
 D375,003 S * 10/1996 Nordstrom, Jr. D17/99
 D392,123 S * 3/1998 Lynch D17/99
 D407,240 S * 3/1999 Payne D17/99
 6,296,213 B1 * 10/2001 Law, III G10G 5/00
 206/45.2
 D464,508 S * 10/2002 Wilfer D6/552
 D538,554 S * 3/2007 Tai D6/682
 D650,611 S * 12/2011 Melhart D6/682.4
 D679,117 S * 4/2013 Werner D6/682.4
 8,770,535 B1 * 7/2014 Yu G10G 5/00
 211/85.6
 D758,769 S * 6/2016 Terpening D6/682
 D782,227 S * 3/2017 Hepburn D6/674
 D782,554 S * 3/2017 Karsten D16/131
 D827,344 S * 9/2018 Dillon D6/682
 2009/0184074 A1 * 7/2009 Jacobson A47B 81/00
 211/85.6

* cited by examiner

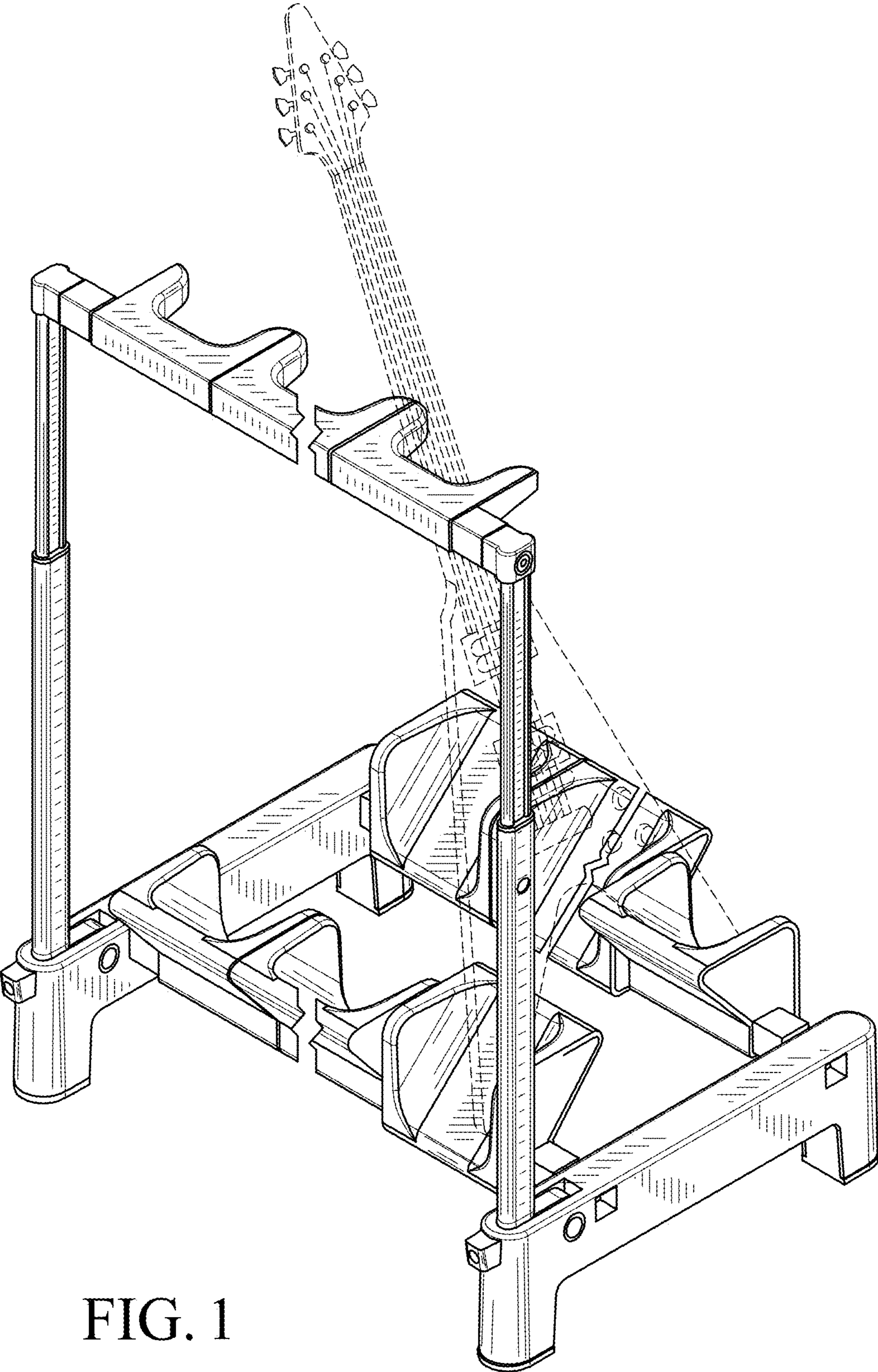

FIG. 1

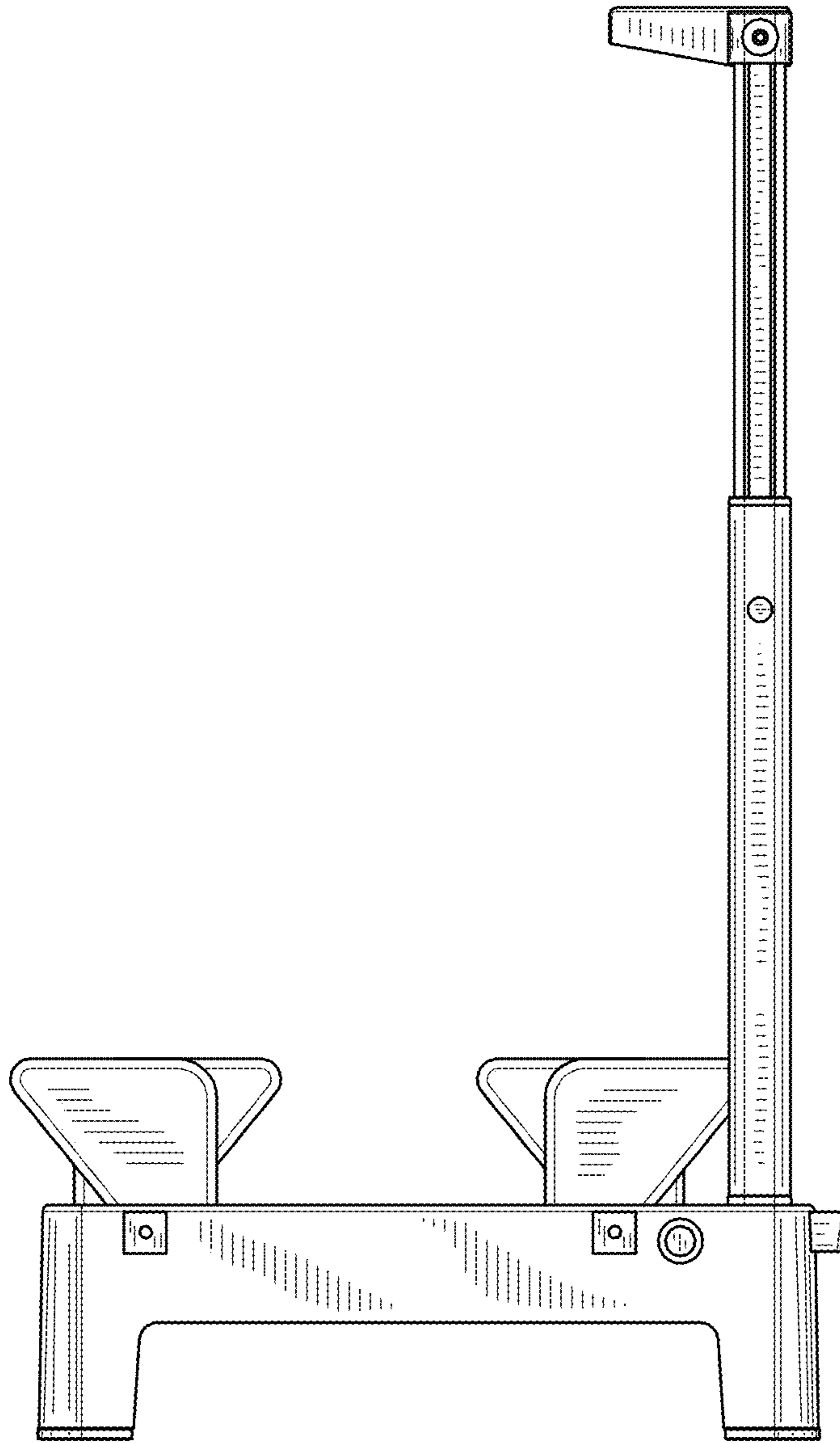

FIG. 2

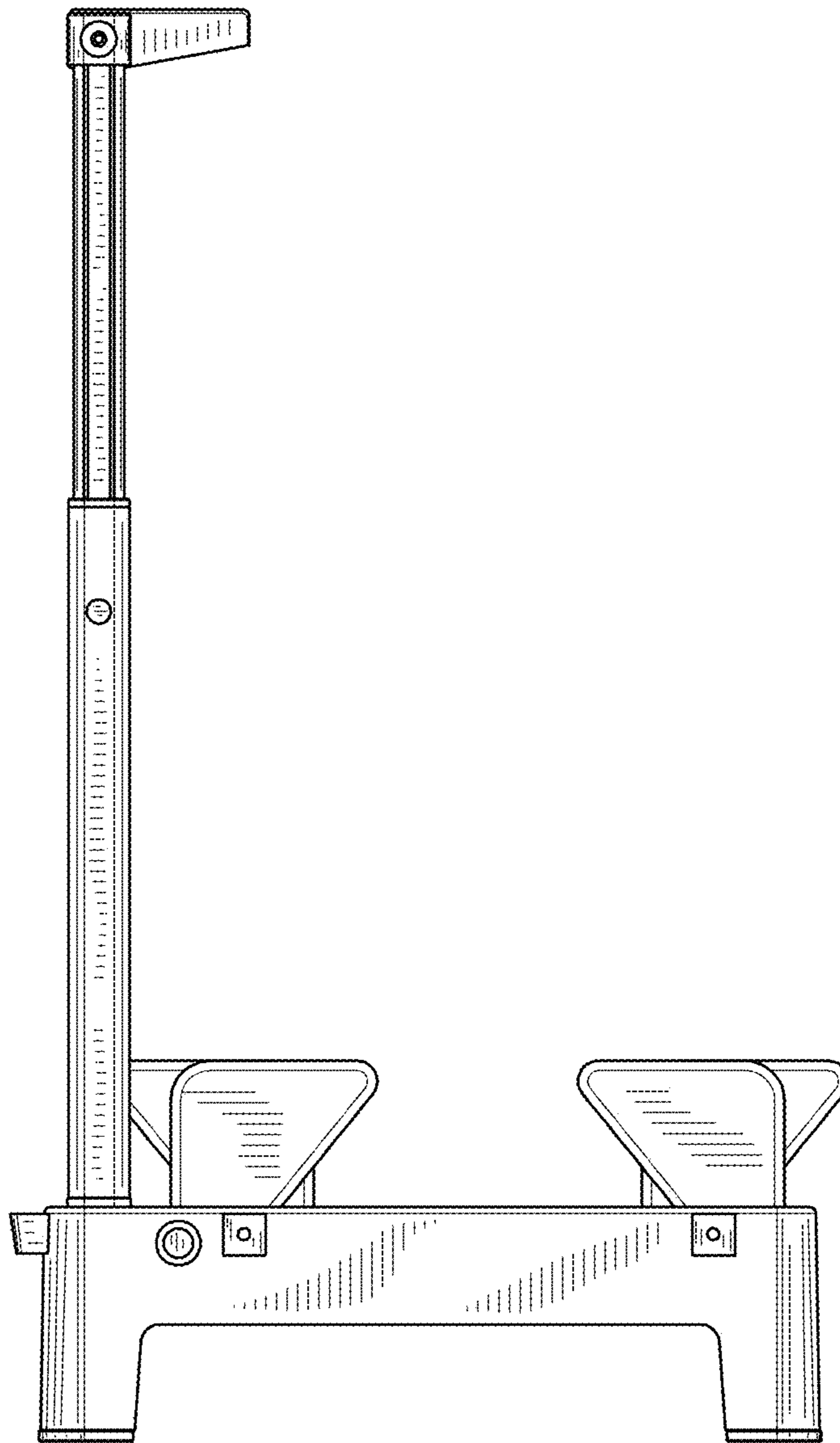

FIG. 3

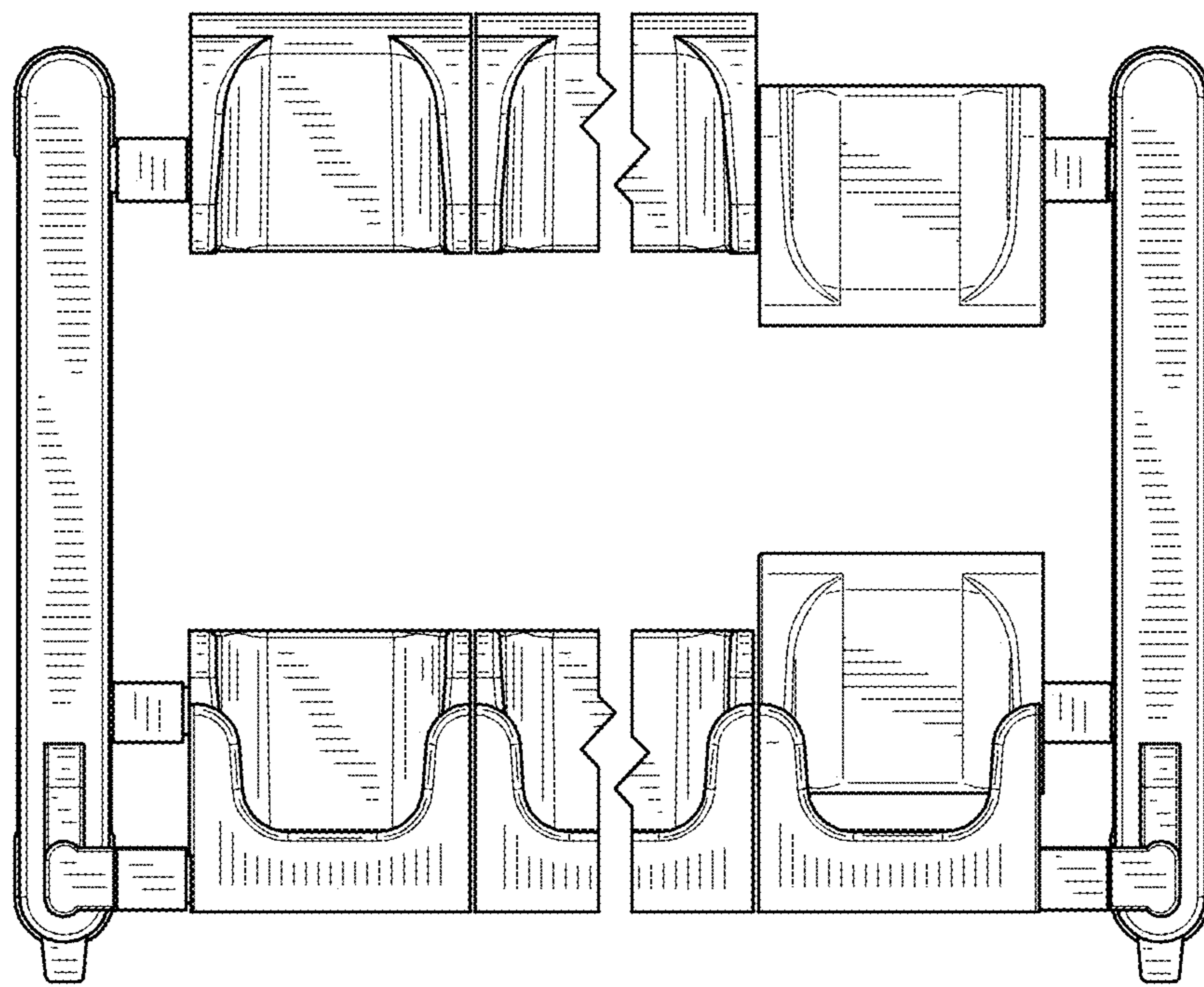

FIG. 4

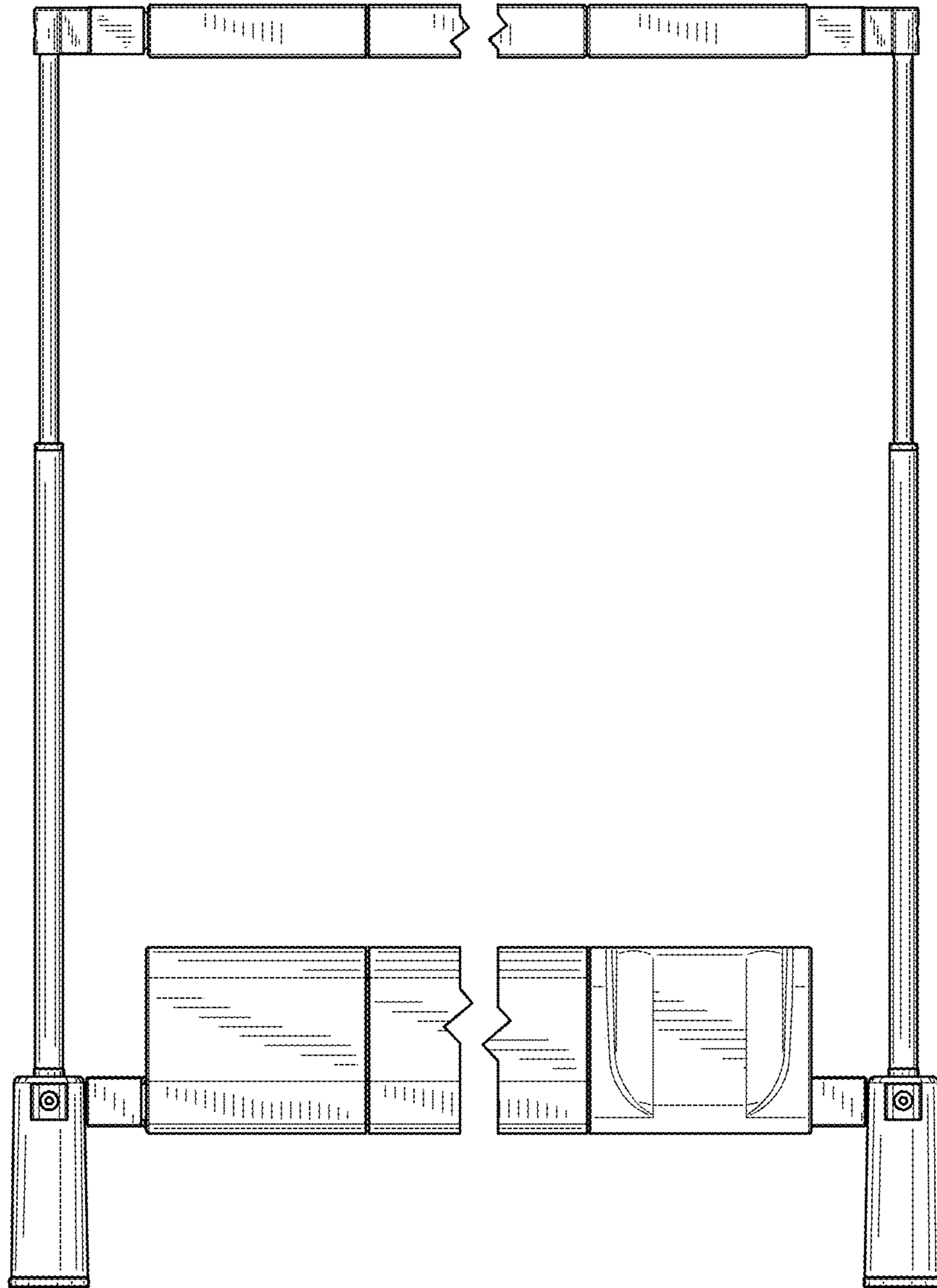

FIG. 5

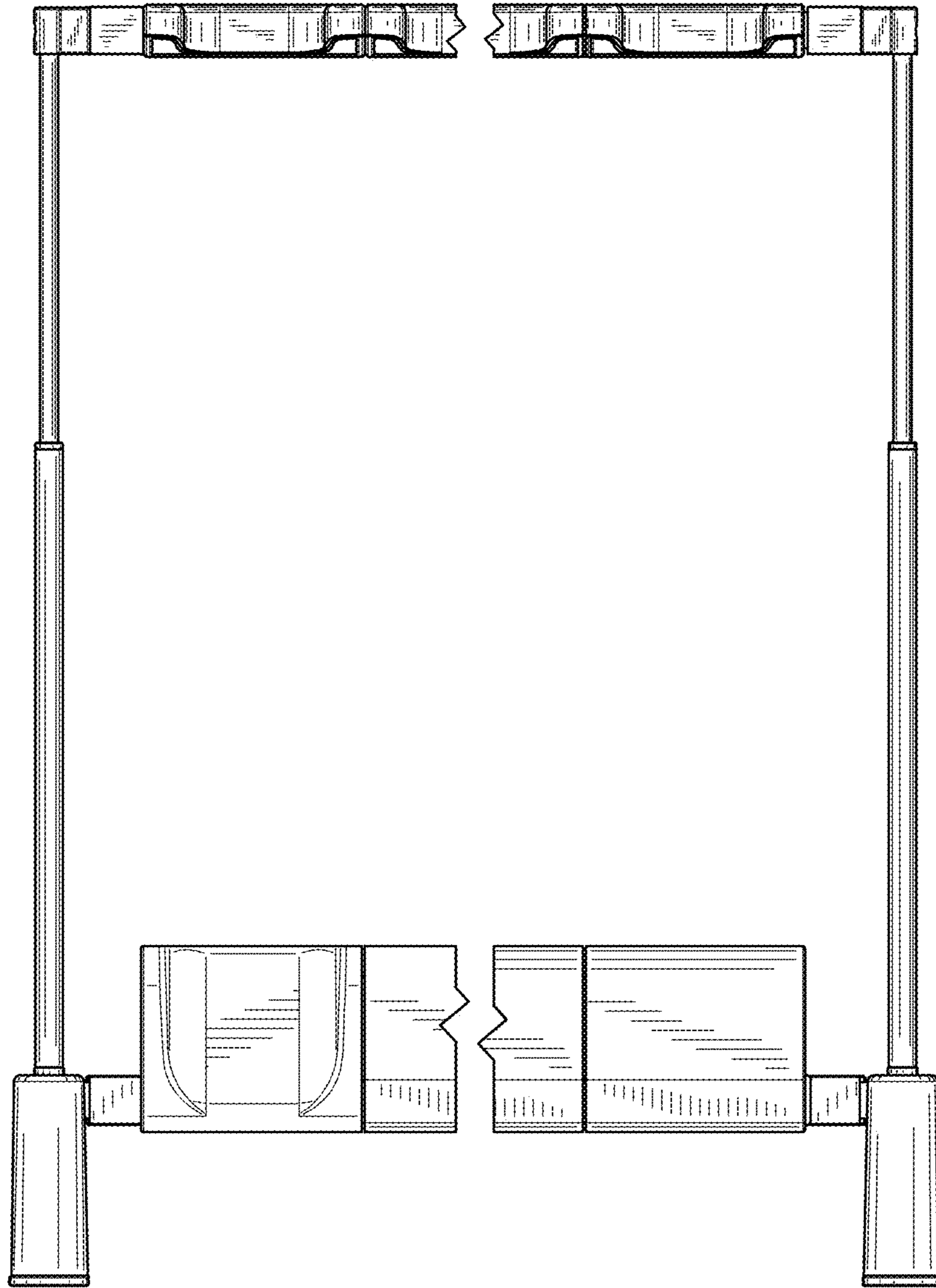

FIG. 6

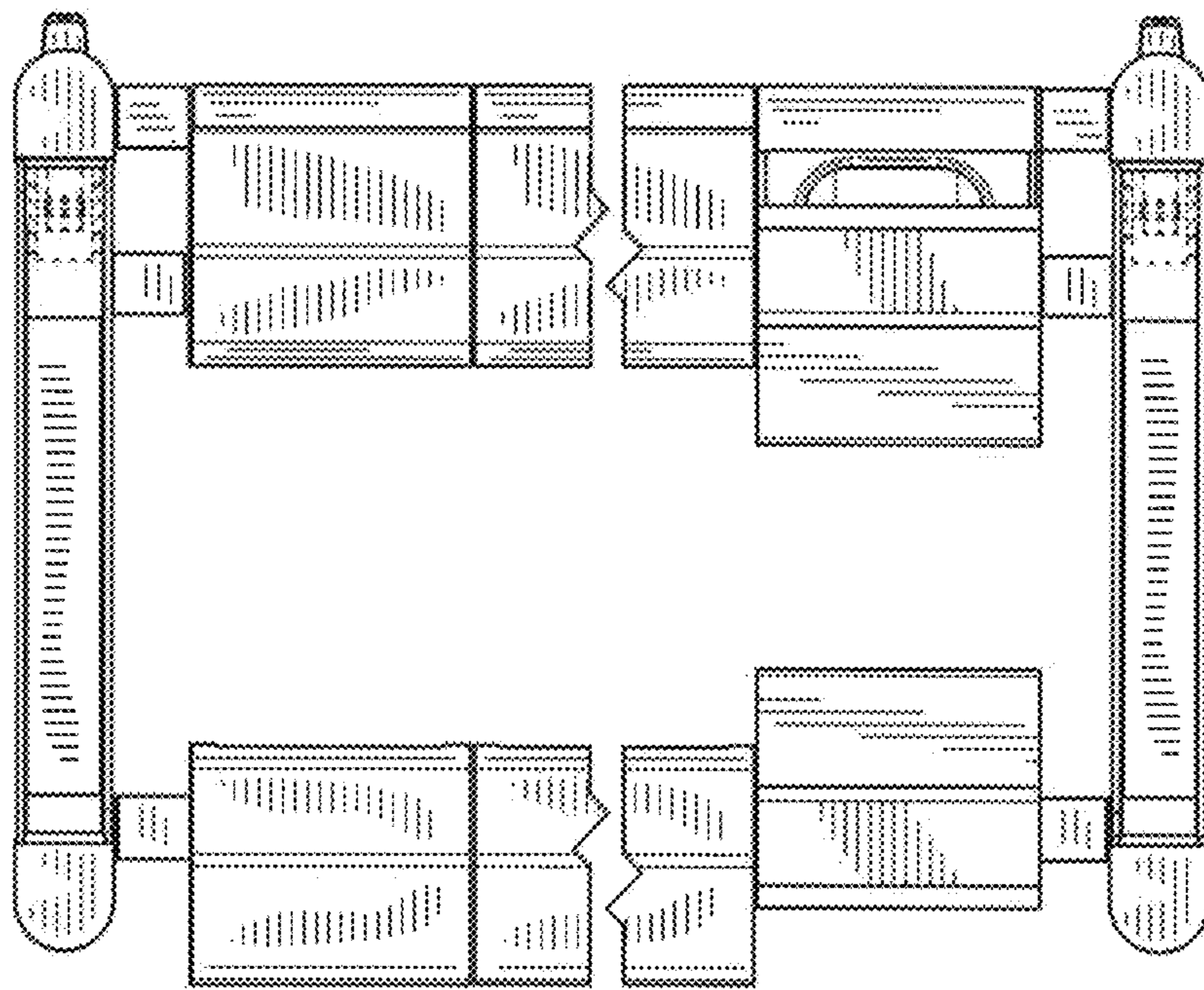

FIG. 7

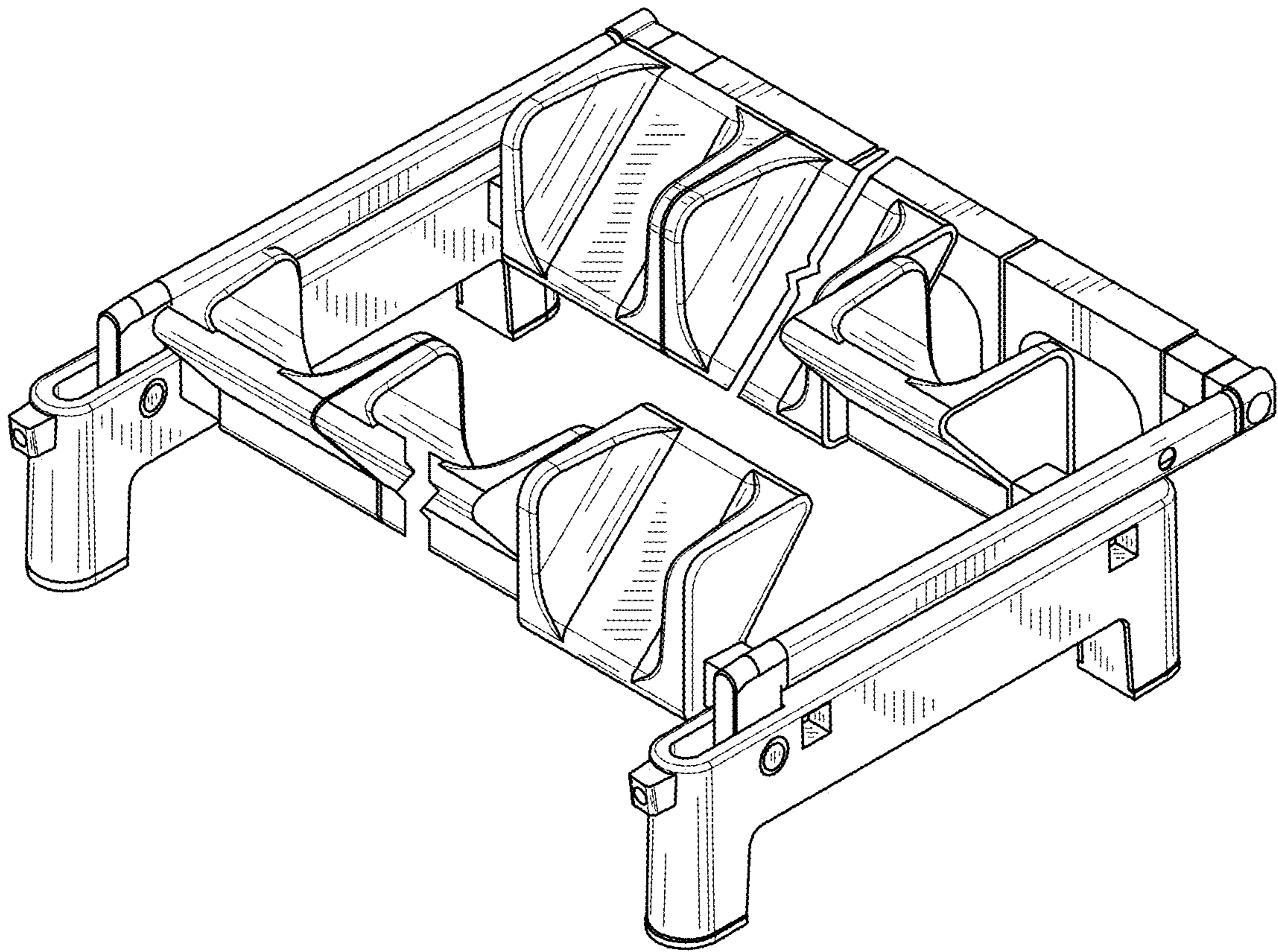

FIG. 8

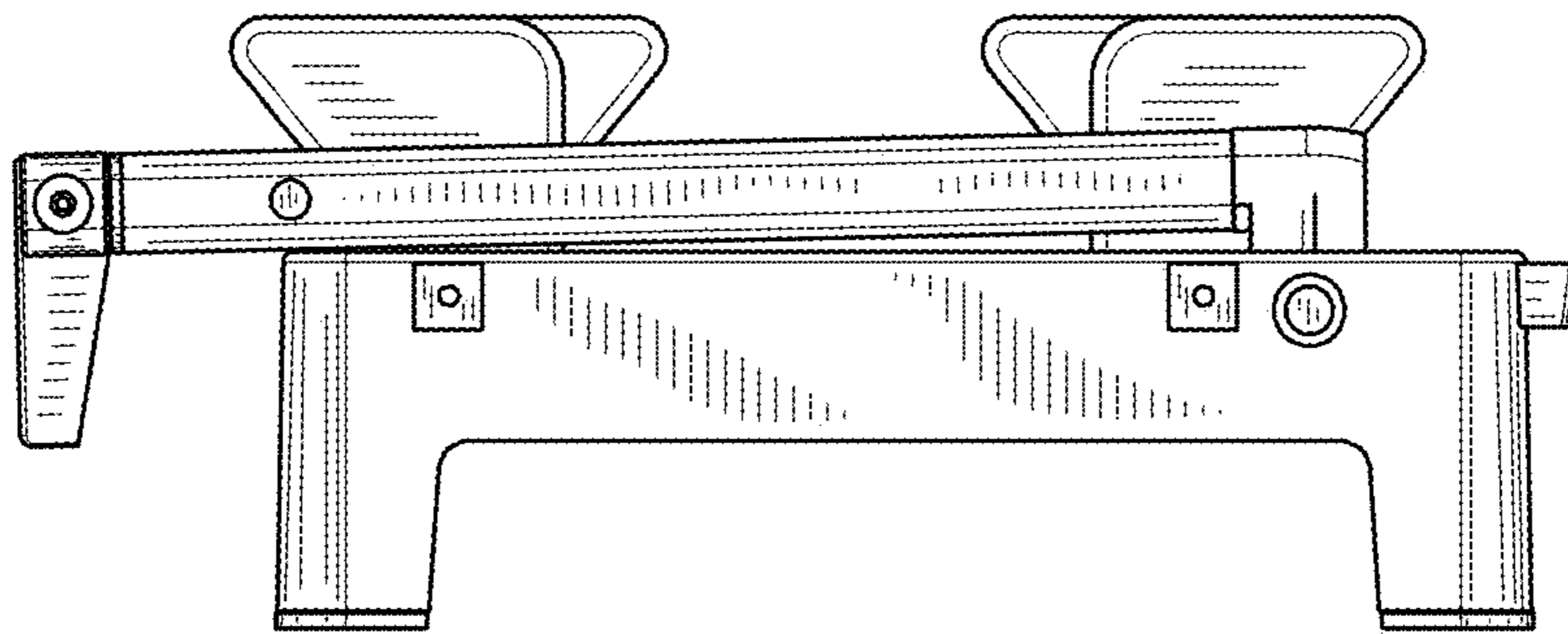

FIG. 9

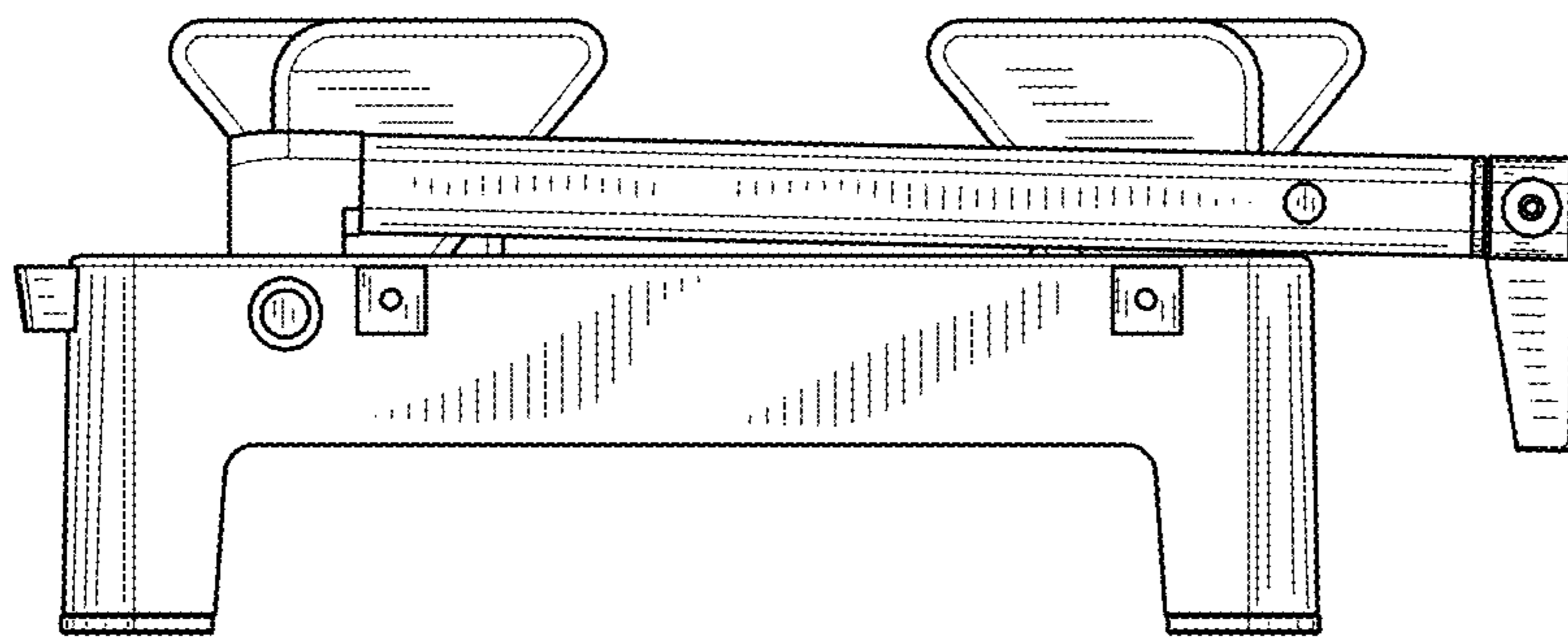

FIG. 10

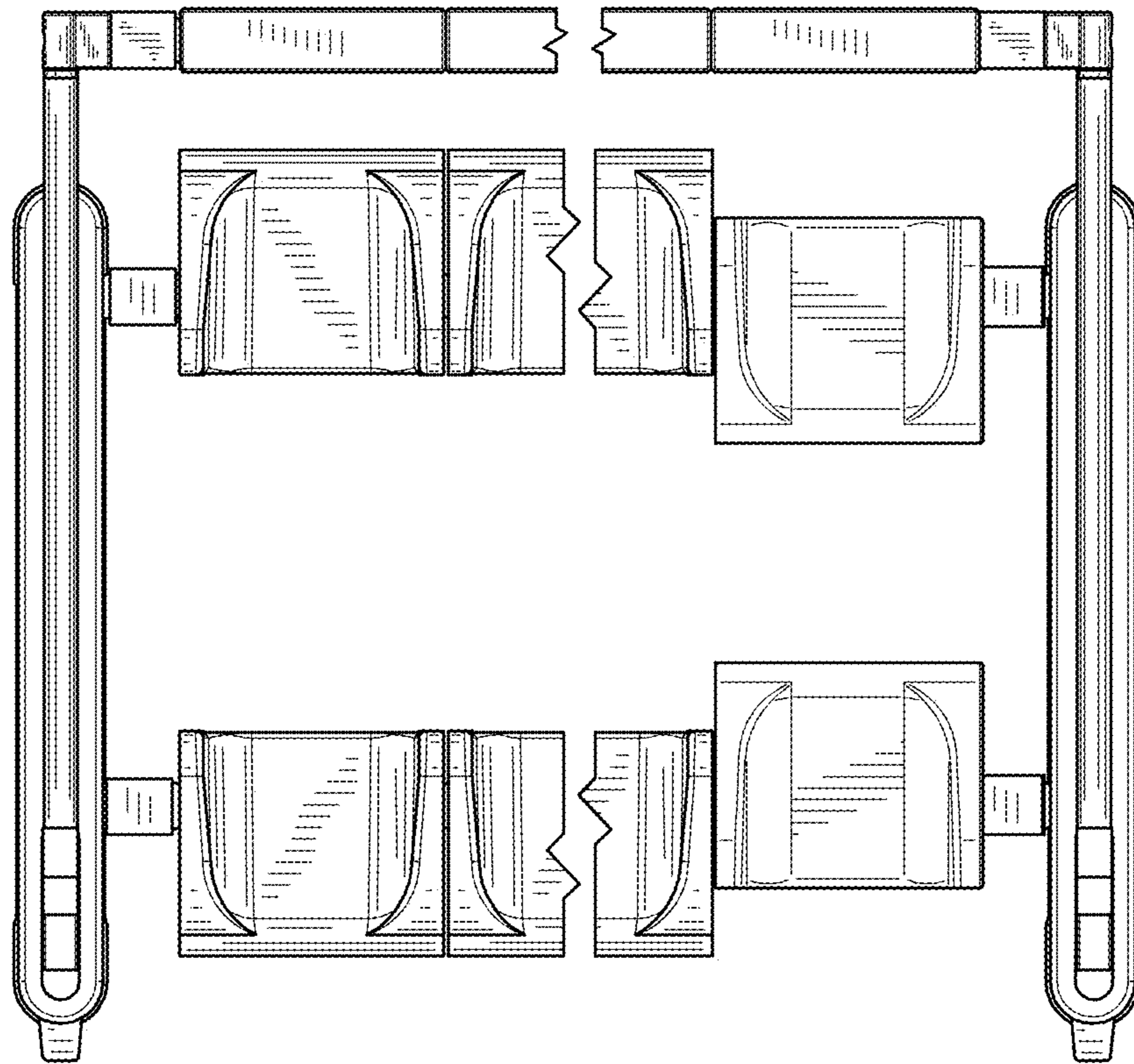

FIG. 11

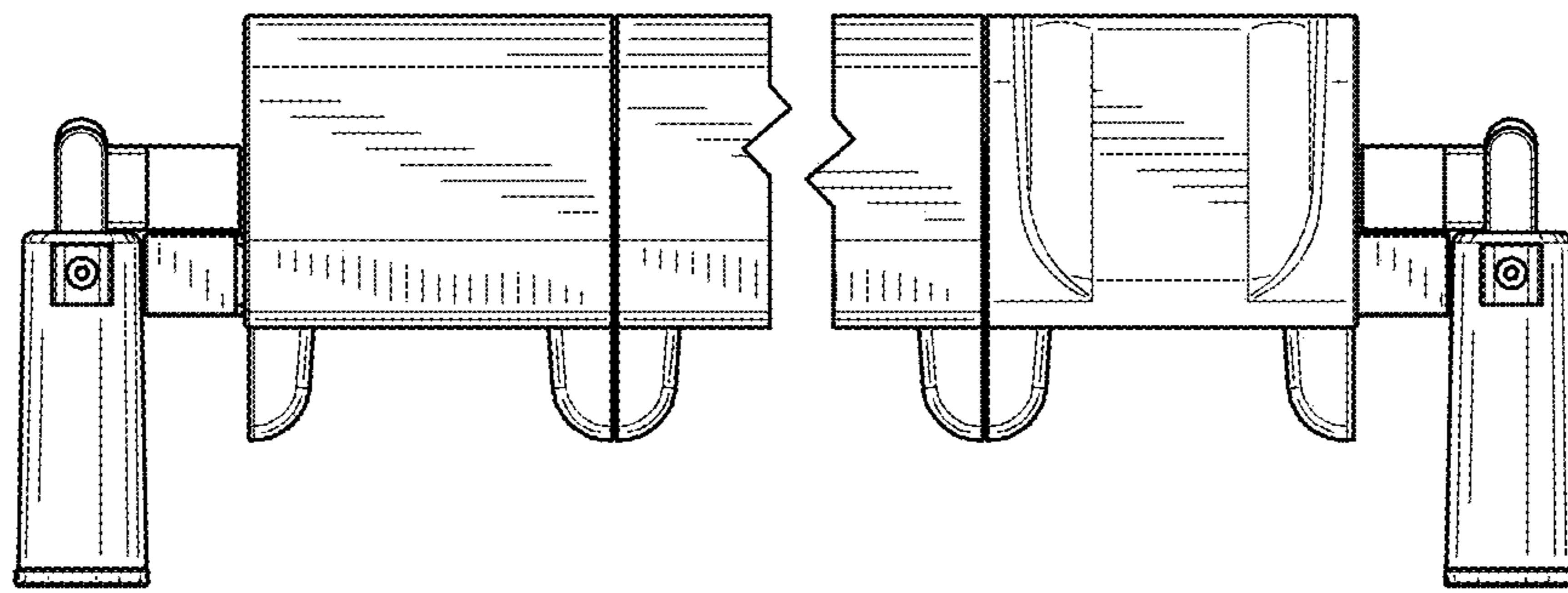

FIG. 12

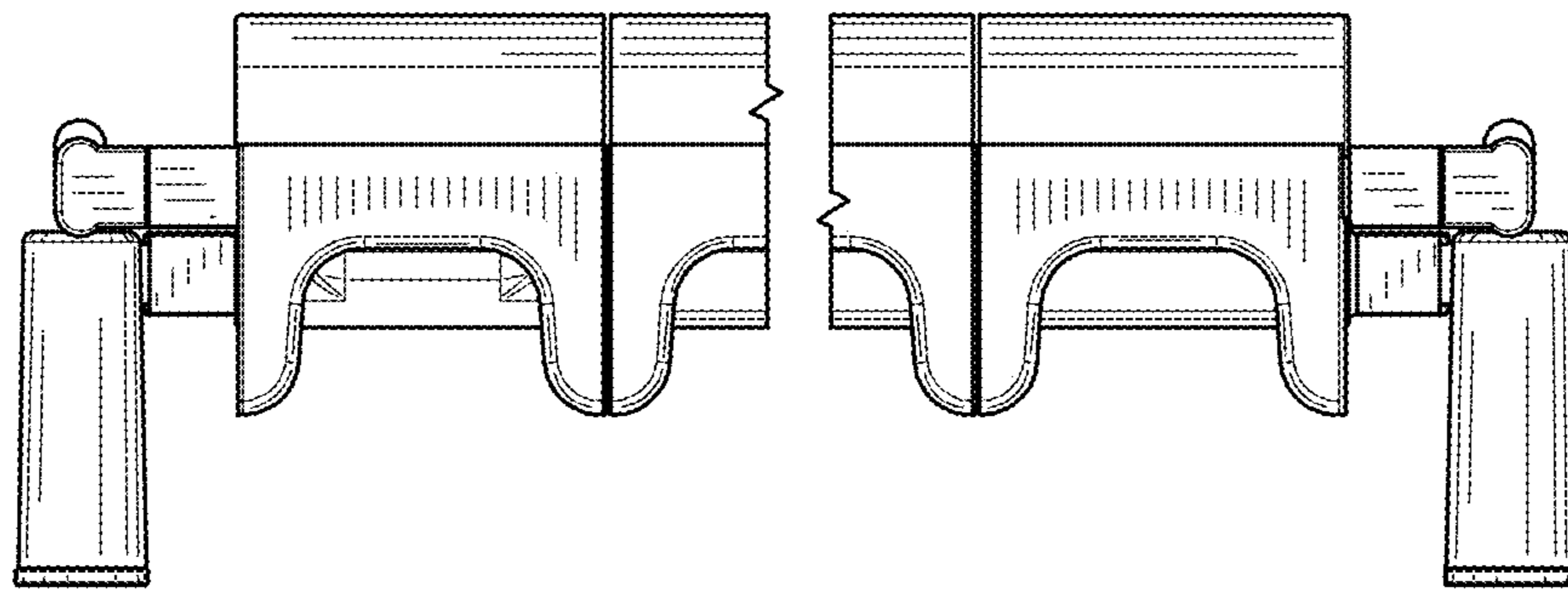

FIG. 13

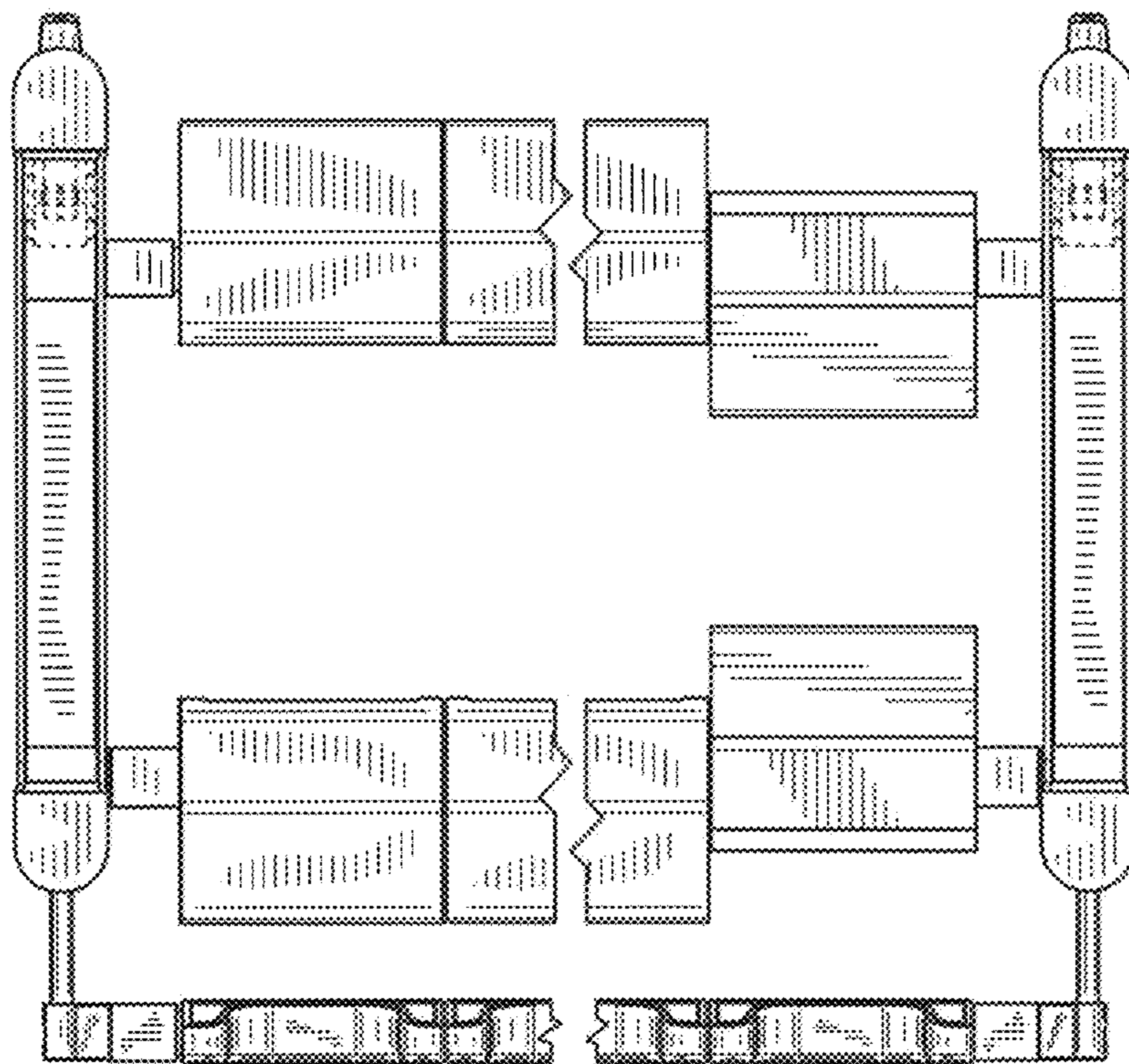

FIG. 14