



US00D875281S

(12) **United States Design Patent** (10) **Patent No.:** **US D875,281 S**
Schmeckpeper (45) **Date of Patent:** **** Feb. 11, 2020**

(54) **VEHICLE REAR TAILLAMP**

(71) Applicant: **GM GLOBAL TECHNOLOGY OPERATIONS LLC**, Detroit, MI (US)

(72) Inventor: **Daniel E. Schmeckpeper**, Clarkston, MI (US)

(73) Assignee: **GM GLOBAL TECHNOLOGY OPERATIONS LLC**, Detroit, MI (US)

(**) Term: **15 Years**

(21) Appl. No.: **29/654,178**

(22) Filed: **Jun. 21, 2018**

(51) **LOC (12) Cl.** **26-06**

(52) **U.S. Cl.**
 USPC **D26/28**

(58) **Field of Classification Search**
 USPC D26/28–36, 139
 CPC F21S 48/00; F21S 48/10; F21S 48/115;
 F21S 48/225; F21S 48/1233; F21S
 48/1266; F21S 48/1388; F21S 48/2268;
 F21V 21/04; B60Q 9/13; B60Q 9/135;
 B60Q 9/1375

See application file for complete search history.

D605,978 S 12/2009 Wolff et al.
 D608,249 S 1/2010 Peters
 D608,690 S 1/2010 Folden et al.
 D608,691 S 1/2010 Zak, Jr. et al.
 D609,608 S 2/2010 Boniface et al.
 D611,387 S 3/2010 Thompson et al.
 D611,879 S 3/2010 Kim et al.
 D612,297 S 3/2010 Peters et al.
 D613,645 S 4/2010 Song et al.
 D615,458 S 5/2010 Thompson et al.
 D618,595 S 6/2010 Ware et al.
 D623,090 S 9/2010 Cox et al.
 D627,262 S 11/2010 Ikeda et al.
 D635,488 S 4/2011 Phipps
 D637,320 S * 5/2011 Yang D26/28
 D644,147 S 8/2011 Suh et al.
 D644,567 S 9/2011 Kozub
 D657,718 S 4/2012 Zipfel et al.
 D659,052 S 5/2012 Ware et al.
 D659,053 S 5/2012 Ware et al.
 D668,182 S 10/2012 Barba Franco et al.

(Continued)

Primary Examiner — Marcus A Jackson

(57) **CLAIM**

The ornamental design for a vehicle rear taillamp, as shown and described.

DESCRIPTION

FIG. 1 is a perspective view of a vehicle rear taillamp showing my new design for mounting on the leftside of a vehicle (the rightside vehicle rear taillamp being a mirror image);

FIG. 2 is a front view of the vehicle rear taillamp of FIG. 1;

FIG. 3 is a side view of the vehicle rear taillamp of FIG. 1; and,

FIG. 4 is a top view of the vehicle rear taillamp of FIG. 1.

The broken lines in the drawings illustrate portions of the vehicle rear taillamp that form no part of the claimed design.

1 Claim, 4 Drawing Sheets

(56) **References Cited**

U.S. PATENT DOCUMENTS

D570,742 S 6/2008 Takagi et al.
 D592,105 S 5/2009 Dean et al.
 D597,447 S 8/2009 Folden
 D600,595 S 9/2009 Nakamura et al.
 D601,925 S 10/2009 O'Donnell
 D603,755 S 11/2009 Peters
 D604,203 S 11/2009 O'Donnell
 D605,082 S 12/2009 Munson
 D605,083 S 12/2009 Manoogian, II et al.
 D605,977 S 12/2009 Zipfel et al.

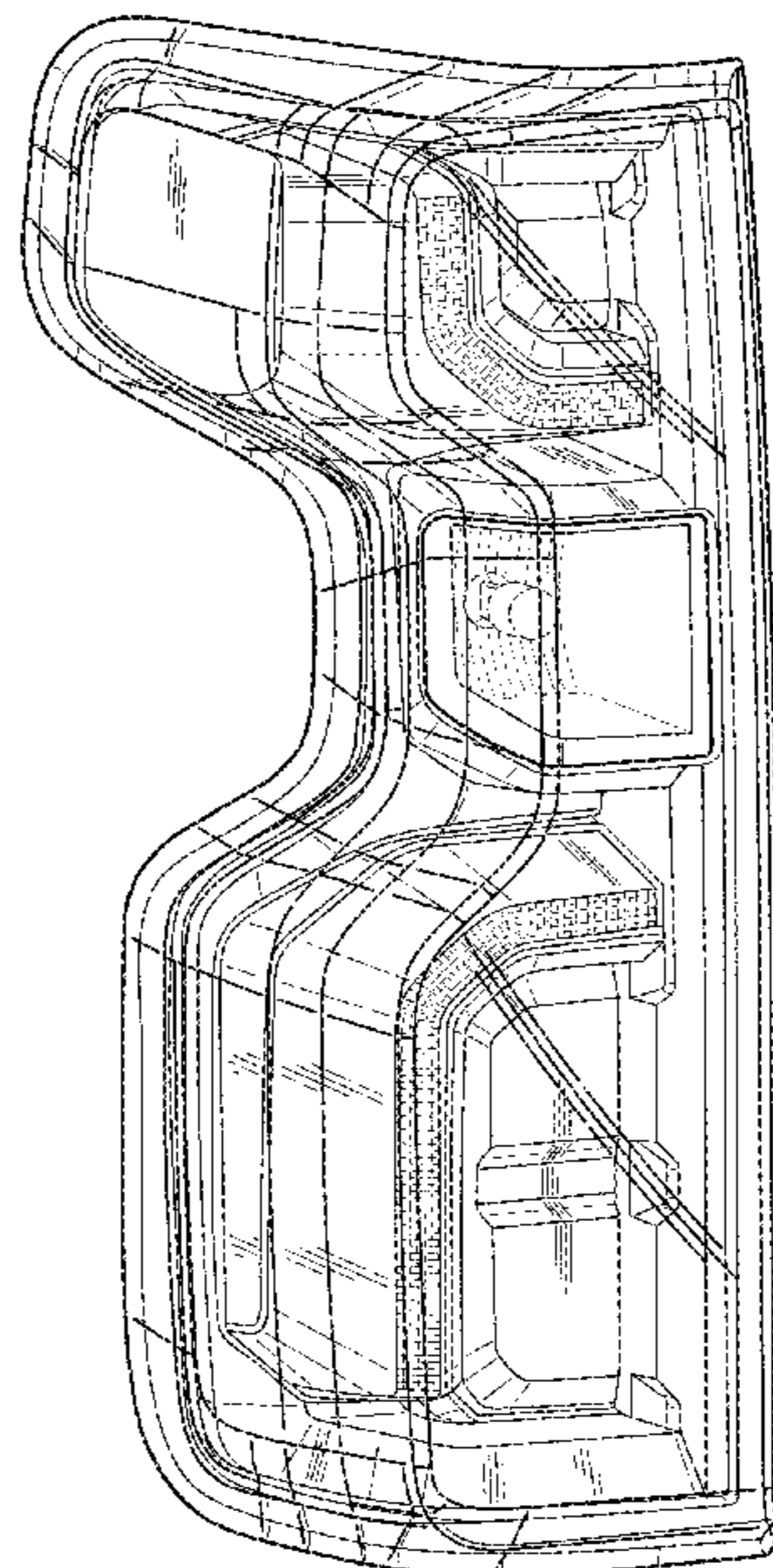

(56)

References Cited

U.S. PATENT DOCUMENTS

D668,183 S	10/2012	Smart		D749,250 S	2/2016	Thole et al.
D678,820 S	3/2013	Son et al.		D749,985 S	2/2016	Kozub et al.
D678,821 S	3/2013	Ikeda et al.		D749,997 S	2/2016	McMahan et al.
D680,909 S	4/2013	Munson et al.		D750,001 S	2/2016	Thole et al.
D680,910 S	4/2013	David		D753,032 S	4/2016	Smith et al.
D684,899 S	6/2013	Baker		D753,033 S	4/2016	Thole et al.
D686,536 S	7/2013	McCabe et al.		D753,034 S	4/2016	Thole et al.
D691,303 S	* 10/2013	Lai	D26/28	D753,035 S	4/2016	Boniface et al.
D692,798 S	11/2013	Thurber		D753,559 S	4/2016	McMahan et al.
D692,799 S	11/2013	Smith et al.		D753,560 S	4/2016	McMahan et al.
D694,442 S	* 11/2013	Lai	D26/28	D753,567 S	4/2016	Boniface et al.
D696,157 S	12/2013	Loeb		D754,571 S	4/2016	Boniface et al.
D699,629 S	2/2014	Ikeda et al.		D754,572 S	4/2016	McMahan et al.
D700,871 S	3/2014	O'Donnell et al.		D755,088 S	5/2016	McMahan et al.
D703,103 S	4/2014	Lee		D756,869 S	5/2016	McMahan et al.
D704,103 S	5/2014	Mack et al.		D758,271 S	6/2016	McMahan et al.
D705,132 S	5/2014	Ware et al.		D764,975 S	8/2016	Aengenheyster
D705,699 S	5/2014	Ware et al.		D764,976 S	8/2016	Aengenheyster
D708,770 S	* 7/2014	Lai	D26/28	D767,449 S	9/2016	Pevovar et al.
D713,298 S	9/2014	Dyson		D767,450 S	9/2016	Lee et al.
D713,764 S	9/2014	Ferlazzo et al.		D767,451 S	9/2016	Kozub et al.
D714,982 S	* 10/2014	Lai	D26/28	D767,454 S	9/2016	McMahan et al.
D716,696 S	11/2014	Thole et al.		D767,458 S	9/2016	Kim
D716,706 S	11/2014	Thole et al.		D767,459 S	9/2016	Kim
D716,709 S	11/2014	Thole et al.		D767,460 S	9/2016	Kozub et al.
D717,696 S	11/2014	Thole et al.		D767,461 S	9/2016	Kozub et al.
D717,980 S	* 11/2014	Lai	D26/28	D771,528 S	11/2016	Smith et al.
D718,189 S	11/2014	Krieg et al.		D771,529 S	11/2016	Thole et al.
D718,683 S	12/2014	Thole et al.		D771,532 S	11/2016	Kapitonov
D722,282 S	2/2015	Loeb		D771,533 S	11/2016	Kapitonov
D722,533 S	2/2015	Thole et al.		D772,766 S	11/2016	Kozub et al.
D722,534 S	2/2015	Munson et al.		D772,767 S	11/2016	Kim
D724,243 S	* 3/2015	Lai	D26/28	D773,084 S	11/2016	Kapitonov
D724,510 S	3/2015	McMahan et al.		D773,086 S	11/2016	McCabe et al.
D725,001 S	3/2015	McMahan et al.		D774,226 S	12/2016	McCabe et al.
D726,591 S	4/2015	Jacob		D775,003 S	12/2016	Pevovar et al.
D730,776 S	6/2015	Smart		D775,007 S	12/2016	Thole et al.
D730,783 S	6/2015	Henriques et al.		D775,010 S	12/2016	Kim et al.
D732,427 S	6/2015	Loeb		D775,049 S	12/2016	Scheer et al.
D732,429 S	6/2015	Loeb		D775,549 S	1/2017	Karras
D732,430 S	6/2015	Loeb		D775,554 S	1/2017	Kapitonov
D732,431 S	6/2015	Loeb		D776,020 S	1/2017	Kapitonov
D732,432 S	6/2015	Aengenheyster		D776,581 S	1/2017	Pevovar et al.
D732,433 S	6/2015	Aengenheyster		D776,583 S	1/2017	Scheer et al.
D732,435 S	6/2015	Mackay		D776,841 S	1/2017	Kozub et al.
D733,002 S	6/2015	Loeb		D776,843 S	1/2017	McCabe et al.
D735,611 S	8/2015	Aengenheyster		D776,846 S	1/2017	Willett et al.
D735,627 S	8/2015	Smith		D777,359 S	1/2017	Kozub et al.
D736,451 S	8/2015	Smith		D777,360 S	1/2017	Kozub et al.
D739,306 S	9/2015	McMahan et al.		D777,361 S	1/2017	Kozub et al.
D739,317 S	9/2015	McMahan et al.		D777,604 S	1/2017	McNerney
D741,223 S	10/2015	Kim et al.		D777,605 S	1/2017	Ferlazzo et al.
D743,309 S	11/2015	Thole et al.		D777,620 S	1/2017	Pevovar et al.
D743,313 S	11/2015	Smith et al.		D777,621 S	1/2017	Kim
D743,314 S	11/2015	Thole et al.		D777,622 S	1/2017	Kozub et al.
D743,857 S	11/2015	McMahan et al.		D777,628 S	1/2017	Kozub et al.
D744,158 S	11/2015	Willett et al.		D777,955 S	1/2017	Willett et al.
D745,086 S	12/2015	Finos et al.		D778,212 S	2/2017	Kozub et al.
D745,719 S	12/2015	Boniface et al.		D778,215 S	2/2017	Kozub et al.
D745,725 S	12/2015	McMahan et al.		D780,064 S	2/2017	Smith et al.
D745,726 S	12/2015	McMahan et al.		D780,067 S	2/2017	Zipfel et al.
D745,837 S	12/2015	Smith et al.		D780,068 S	2/2017	Whitla et al.
D746,726 S	1/2016	Smith et al.		D780,077 S	2/2017	Kim et al.
D746,727 S	1/2016	Smith et al.		D780,081 S	2/2017	Lee
D746,728 S	1/2016	Smith et al.		D780,084 S	2/2017	Scheer et al.
D746,729 S	1/2016	Boniface et al.		D780,631 S	3/2017	Kozub et al.
D746,730 S	1/2016	Kim et al.		D780,644 S	3/2017	Kim et al.
D747,514 S	1/2016	McMahan et al.		D781,184 S	3/2017	Thole et al.
D747,515 S	1/2016	McMahan et al.		D781,192 S	3/2017	Kozub et al.
D747,819 S	1/2016	Thole et al.		D782,379 S	3/2017	Wassell
D749,021 S	2/2016	Boniface et al.		D783,482 S	4/2017	Smith et al.
D749,026 S	2/2016	Smith et al.		D784,213 S	4/2017	Karras
D749,027 S	2/2016	McMahan et al.		D784,223 S	4/2017	Lee
D749,246 S	2/2016	Thole et al.		D784,226 S	4/2017	Cheng
D749,249 S	2/2016	Thole et al.		D784,579 S	4/2017	Cheng et al.
				D784,877 S	4/2017	Lee
				D784,886 S	4/2017	Smith et al.
				D785,521 S	5/2017	Smith et al.
				D786,149 S	5/2017	Pevovar et al.

(56)

References Cited

U.S. PATENT DOCUMENTS

D786,743 S	5/2017	Smith et al.	D802,478 S	11/2017	Perkins
D786,750 S	5/2017	Lee	D802,491 S	11/2017	Mainville
D787,446 S	5/2017	Cockerill	D802,496 S	11/2017	Mainville
D787,984 S	5/2017	Fang	D802,502 S	11/2017	McMahan
D787,988 S	5/2017	Lee	D803,727 S	11/2017	Noone et al.
D787,989 S	5/2017	Kozub et al.	D803,731 S	11/2017	Zipfel
D787,990 S	5/2017	Kozub et al.	D804,370 S	12/2017	Kozub et al.
D787,992 S	5/2017	Lee	D804,371 S	12/2017	Whitla et al.
D787,993 S	5/2017	McCabe et al.	D804,372 S	12/2017	Kozub
D788,001 S	5/2017	Lee	D804,378 S	12/2017	Perkins
D788,641 S	6/2017	Arnold	D804,379 S	12/2017	McMahan
D788,644 S	6/2017	Mueller	D805,006 S	12/2017	Nakamura
D788,645 S	6/2017	Mueller	D805,013 S	12/2017	Whitla et al.
D789,250 S	6/2017	Arnold	D805,014 S	12/2017	Zipfel et al.
D789,260 S	6/2017	Smith	D805,441 S	12/2017	Karras
D789,575 S	6/2017	Willett	D805,964 S	12/2017	Whitla et al.
D789,841 S	6/2017	Lee	D805,965 S	12/2017	Davis
D789,849 S	6/2017	Lee	D805,966 S	12/2017	Perkins
D791,018 S	7/2017	Mylenek	D805,985 S	12/2017	Nakamura
D791,644 S	7/2017	Fang	D807,232 S	1/2018	Bailie
D792,290 S	7/2017	Smith et al.	D807,239 S	1/2018	Perkins
D792,293 S	7/2017	McCabe et al.	D807,240 S	1/2018	Perkins
D792,294 S	7/2017	McCabe et al.	D807,241 S	1/2018	Perkins
D792,295 S	7/2017	McCabe et al.	D809,442 S	2/2018	Zipfel et al.
D792,815 S	7/2017	Kozub	D811,269 S	2/2018	Thompson et al.
D792,816 S	7/2017	Kozub	D811,942 S	3/2018	Jacob
D793,290 S	8/2017	Kozub	D811,957 S	3/2018	Whitla et al.
D793,292 S	8/2017	Lee	D811,958 S	3/2018	Zipfel et al.
D793,293 S	8/2017	Lee et al.	D811,959 S	3/2018	Perkins
D793,294 S	8/2017	Lee	D811,960 S	3/2018	Nakamura
D793,295 S	8/2017	McCabe et al.	D811,961 S	3/2018	Sullivan
D793,296 S	8/2017	Smith et al.	D811,962 S	3/2018	Sullivan
D793,297 S	8/2017	Smith et al.	D811,963 S	3/2018	Sullivan
D793,299 S	8/2017	Krieg et al.	D811,964 S	3/2018	Perkins
D793,300 S	8/2017	Krieg et al.	D811,965 S	3/2018	Moffett et al.
D793,301 S	8/2017	Kozub	D812,525 S	3/2018	Lee
D793,302 S	8/2017	Kozub	D812,526 S	3/2018	Zipfel et al.
D793,311 S	8/2017	Whitla et al.	D812,527 S	3/2018	Perkins
D793,590 S	8/2017	Kozub et al.	D812,528 S	3/2018	Nakamura
D793,591 S	8/2017	Kozub et al.	D813,098 S	3/2018	Thompson et al.
D793,917 S	8/2017	Kozub	D813,109 S	3/2018	Zipfel et al.
D793,918 S	8/2017	Kozub	D813,110 S	3/2018	Whitla et al.
D794,229 S	8/2017	Barry	D813,111 S	3/2018	Sullivan
D794,230 S	8/2017	Kozub	D813,116 S	3/2018	Park
D795,747 S	8/2017	Bailie	D813,117 S	3/2018	Sullivan
D795,757 S	8/2017	Pevovar et al.	D813,121 S	3/2018	Swanseger
D795,758 S	8/2017	Karras	D813,730 S	3/2018	Zipfel et al.
D795,759 S	8/2017	Kozub et al.	D813,731 S	3/2018	McMahan
D795,760 S	8/2017	Kozub et al.	D813,732 S	3/2018	Whitla et al.
D795,762 S	8/2017	Lee	D813,733 S	3/2018	Lee
D795,763 S	8/2017	Kozub	D813,734 S	3/2018	Nakamura
D796,088 S	8/2017	McCabe et al.	D813,740 S	3/2018	Park
D796,093 S	8/2017	Mainville	D813,741 S	3/2018	Perkins
D796,390 S	9/2017	Pevovar et al.	D813,742 S	3/2018	McMahan et al.
D797,537 S	9/2017	Cooper et al.	D813,743 S	3/2018	Lee
D797,603 S	9/2017	Noone et al.	D813,744 S	3/2018	Whitla et al.
D797,614 S	9/2017	Lee	D813,748 S	3/2018	Kim
D797,616 S	9/2017	Lee	D813,753 S	3/2018	Loeb
D797,624 S	9/2017	Nakamura	D813,754 S	3/2018	Loeb
D797,625 S	9/2017	Perkins	D813,755 S	3/2018	Loeb
D797,631 S	9/2017	Pevovar et al.	D813,756 S	3/2018	Loeb
D797,632 S	9/2017	Zipfel et al.	D813,757 S	3/2018	Kozub
D797,967 S	9/2017	Barry	D813,758 S	3/2018	Gonzales
D797,970 S	9/2017	Mainville	D813,759 S	3/2018	Perkins
D797,971 S	9/2017	Mainville	D814,369 S	4/2018	Loeb
D797,972 S	9/2017	Whitla et al.	D814,982 S	4/2018	Whitla et al.
D798,204 S	9/2017	Mainville	D814,983 S	4/2018	Whitla et al.
D799,384 S	10/2017	Kozub et al.	D815,570 S	4/2018	McMahan et al.
D799,385 S	10/2017	Kozub et al.	D815,572 S	4/2018	Perkins
D799,386 S	10/2017	Kozub et al.	D815,573 S	4/2018	Whitla et al.
D799,728 S	10/2017	Whitla et al.	D815,574 S	4/2018	Mainville
D801,236 S	10/2017	Kozub et al.	D815,993 S	4/2018	Kozub et al.
D801,577 S	10/2017	Ruiz	D815,994 S	4/2018	Nakamura
D801,882 S	11/2017	Kozub et al.	D816,003 S	4/2018	Perkins
D802,205 S	11/2017	Ruiz	D816,558 S	5/2018	McMahan et al.
			D816,559 S	5/2018	McMahan et al.
			D816,561 S	5/2018	McMahan
			D816,562 S	5/2018	Whitla et al.
			D816,563 S	5/2018	McMahan et al.

(56)

References Cited

U.S. PATENT DOCUMENTS

D816,564 S	5/2018	Kim
D816,565 S	5/2018	Kim
D816,566 S	5/2018	Loeb
D817,836 S	5/2018	McMahan et al.
D818,156 S	5/2018	Kim et al.
D818,157 S	5/2018	Zipfel et al.
D818,158 S	5/2018	Zipfel et al.
D818,159 S	5/2018	Zipfel et al.
D818,160 S	5/2018	Perkins
D818,406 S	5/2018	McMahan et al.
D818,876 S	5/2018	Whitla et al.
D818,877 S	5/2018	Nakamura et al.
D818,878 S	5/2018	McMahan et al.
D818,892 S	5/2018	Lee
D818,893 S	5/2018	Kim
D818,903 S	5/2018	Zipfel et al.
D818,906 S	5/2018	McMahan
D818,907 S	5/2018	Whitla et al.
D818,915 S	5/2018	Kozub et al.
D818,922 S	5/2018	Whitla et al.
D819,505 S	6/2018	McMahan et al.
D819,519 S	6/2018	Whitla et al.

* cited by examiner

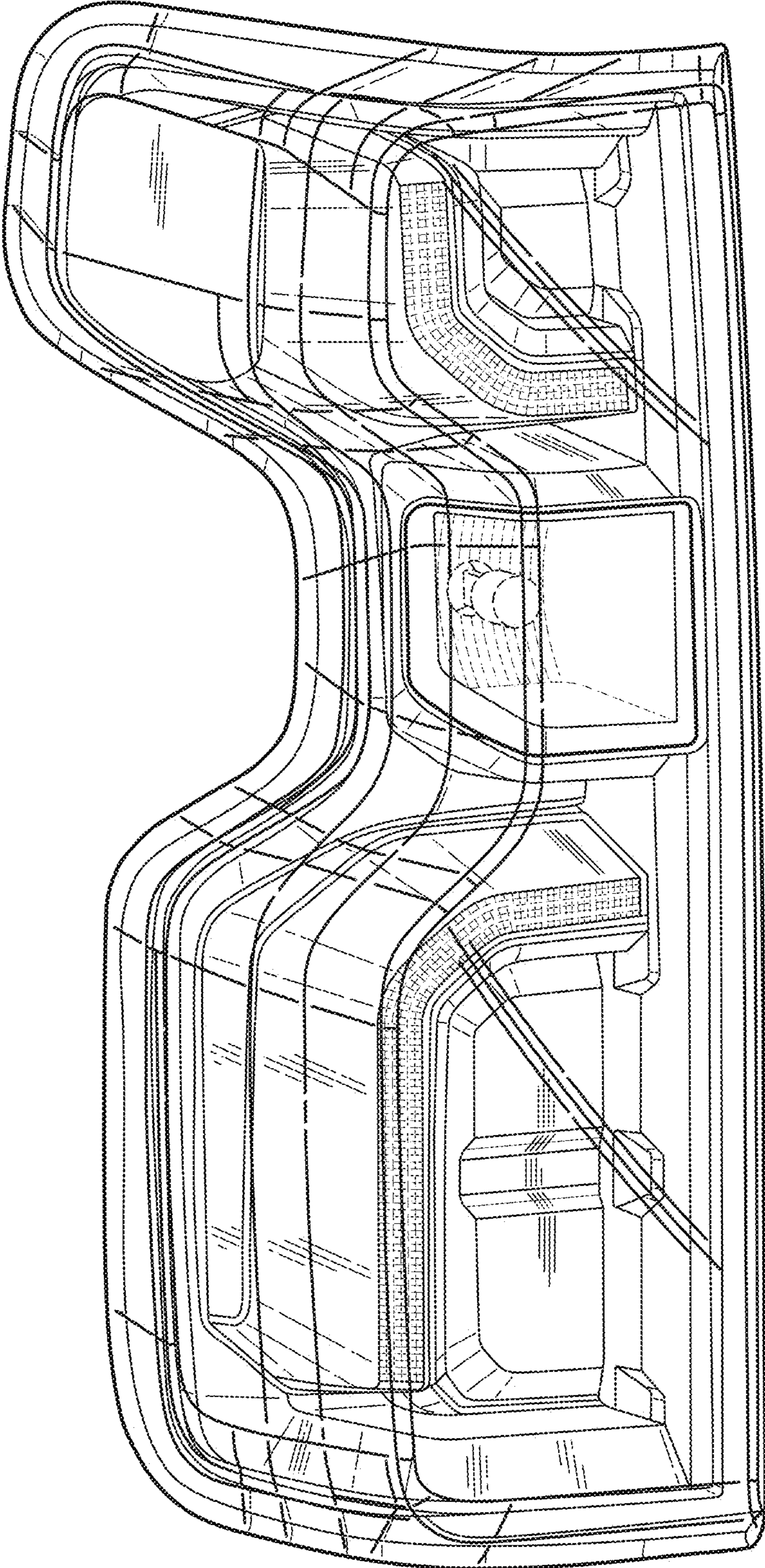

FIG. 1

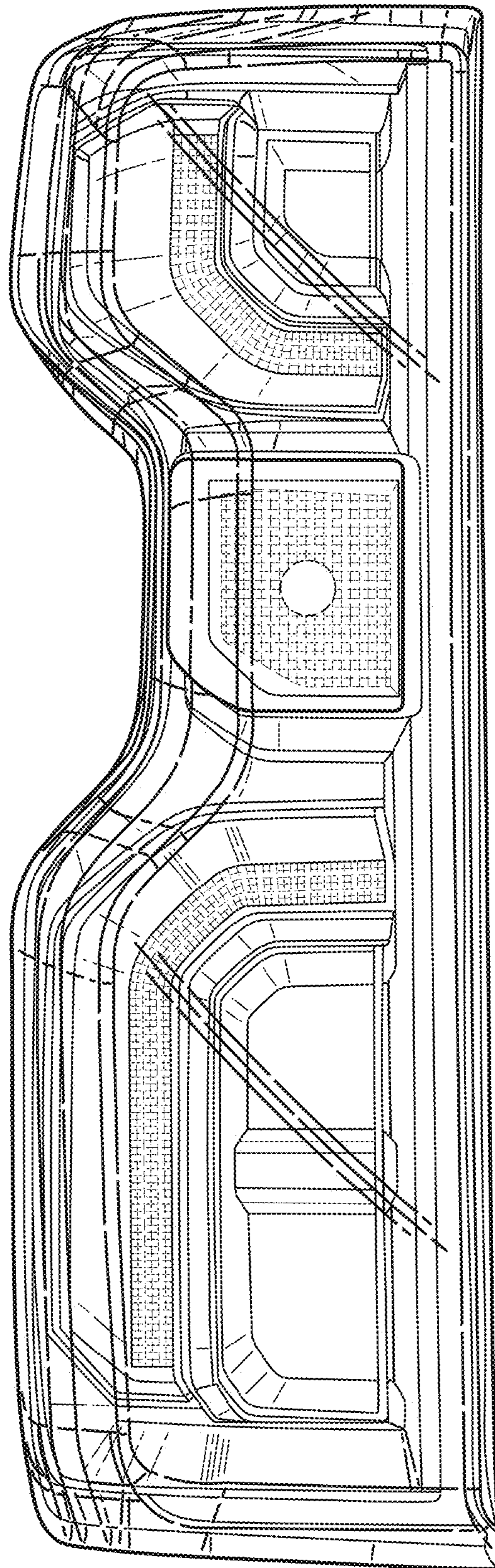
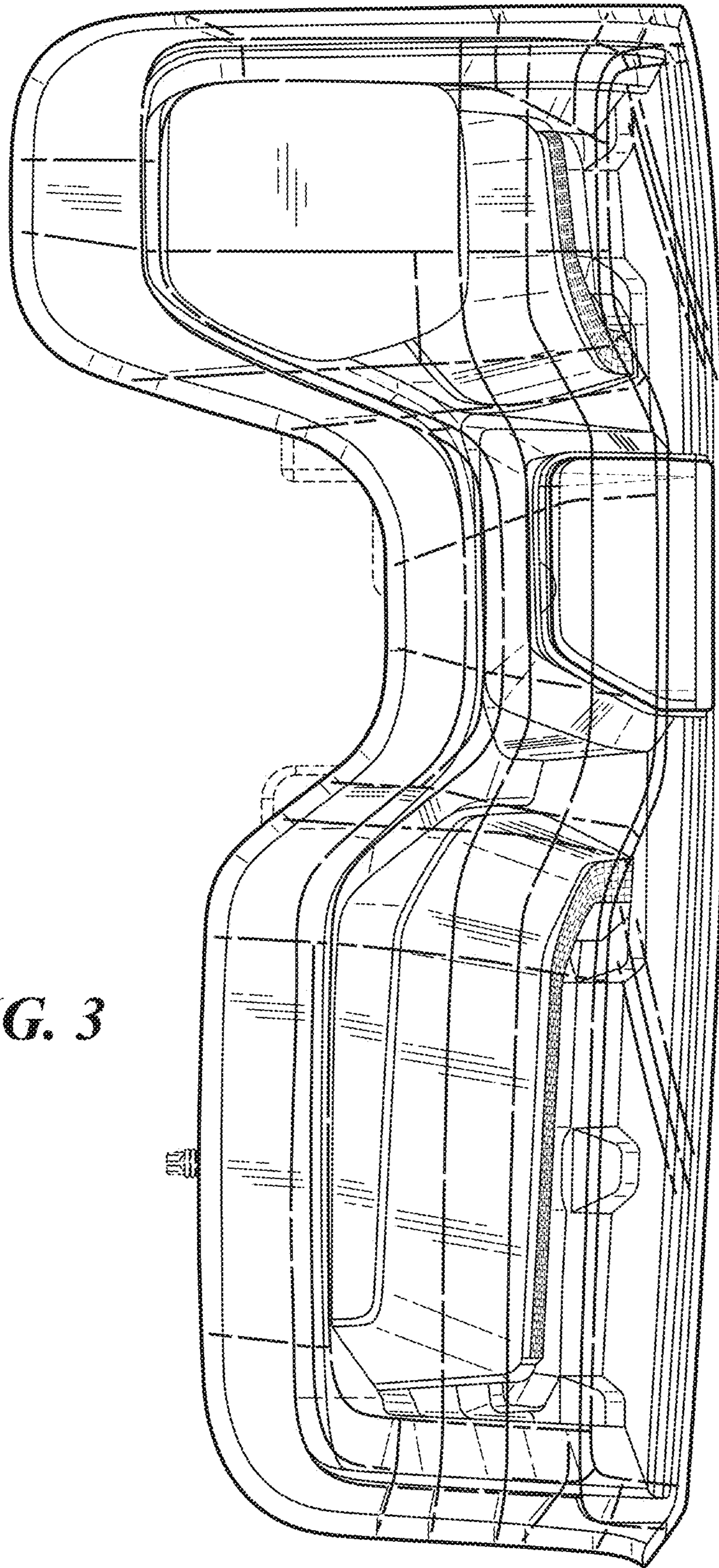

FIG. 2

FIG. 3



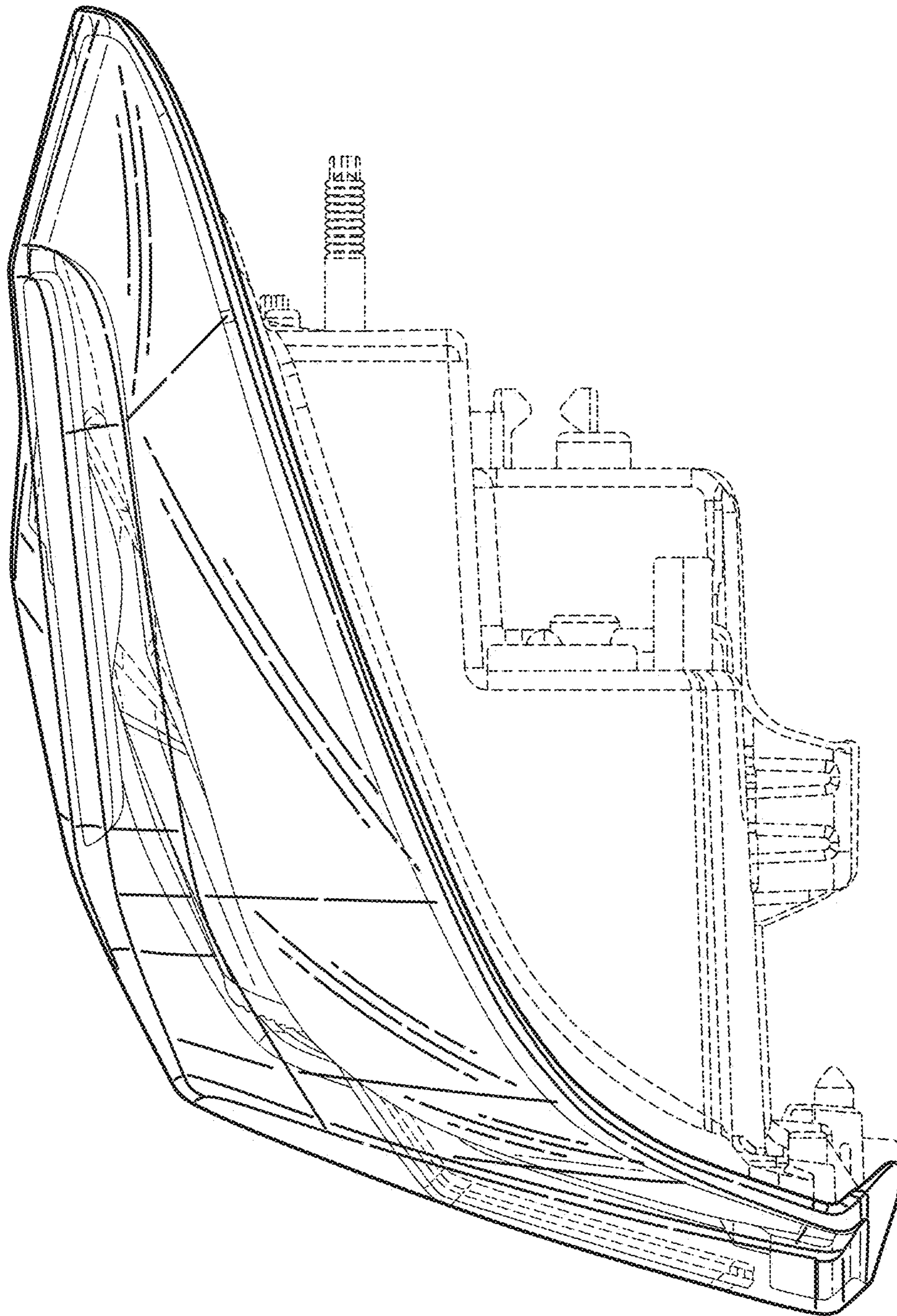

FIG. 4