

US00D875186S

(12) **United States Design Patent**  
**Ewing et al.**

(10) **Patent No.:** **US D875,186 S**

(45) **Date of Patent:** **\*\* Feb. 11, 2020**

(54) **UPPER FRONT SUSPENSION ARM FOR A MODEL VEHICLE**

(71) Applicant: **TRAXXAS LP**, McKinney, TX (US)

(72) Inventors: **Adam Cole Ewing**, McKinney, TX (US); **Otto Karl Allmendinger**, Rowlett, TX (US)

(73) Assignee: **TRAXXAS LP**, McKinney, TX (US)

(\*\*) Term: **15 Years**

(21) Appl. No.: **29/632,885**

(22) Filed: **Jan. 10, 2018**

(51) **LOC (12) Cl.** ..... **21-01**

(52) **U.S. Cl.**  
USPC ..... **D21/561**; D12/159

(58) **Field of Classification Search**  
USPC ..... D21/495, 561; D12/159-160  
(Continued)

(56) **References Cited**

**U.S. PATENT DOCUMENTS**

903,080 A 11/1908 Granieri  
951,000 A 3/1910 Ewing

(Continued)

**FOREIGN PATENT DOCUMENTS**

DE 2137757 A1 2/1973  
DE 3622552 A1 \* 1/1988 ..... B60G 3/20

(Continued)

**OTHER PUBLICATIONS**

CN-304138171, posted at Orbit.com, publication date May 17, 2017. Site visited Apr. 12, 2019. Available from Internet. (Year: 2017).\*

(Continued)

*Primary Examiner* — Kevin K Rudzinski

*Assistant Examiner* — Kathleen L Jones

(74) *Attorney, Agent, or Firm* — Daryl R. Wright; Greg Carr

(57) **CLAIM**

We claim the ornamental design for an upper front suspension arm for a model vehicle, as shown and described.

**DESCRIPTION**

FIG. 1 is a top, left, front perspective view of a first embodiment of an upper front suspension arm for a model vehicle;

FIG. 2 is a front elevation view thereof;

FIG. 3 is a rear elevation view thereof;

FIG. 4 is a right side elevation view thereof;

FIG. 5 is a left side elevation view thereof;

FIG. 6 is a top plan view thereof;

FIG. 7 is a bottom plan view thereof;

FIG. 8 is a lower, left, rear perspective view;

FIG. 9 is an upper, left, front perspective view thereof showing the upper front suspension arm for a model vehicle within a broken line environment of use; and,

FIG. 10 is an enlarged detail view of the upper front suspension arm for a model vehicle shown in FIG. 9.

In the drawings, the broken line showing of features of the upper front suspension arm for a model vehicle illustrate portions of the upper front suspension arm for a model vehicle that form no part of the claimed design; whereas, the broken lines showing a model vehicle in FIGS. 9-10 are included to illustrate environmental structure and form no part of the claimed design.

In the drawings, only the first embodiment of an upper front suspension arm for a model vehicle is shown. The second embodiment of the claimed design is a right upper front suspension arm for a model vehicle, which is a mirror image of the left upper front suspension arm for a model vehicle disclosed in the first embodiment.

**1 Claim, 8 Drawing Sheets**

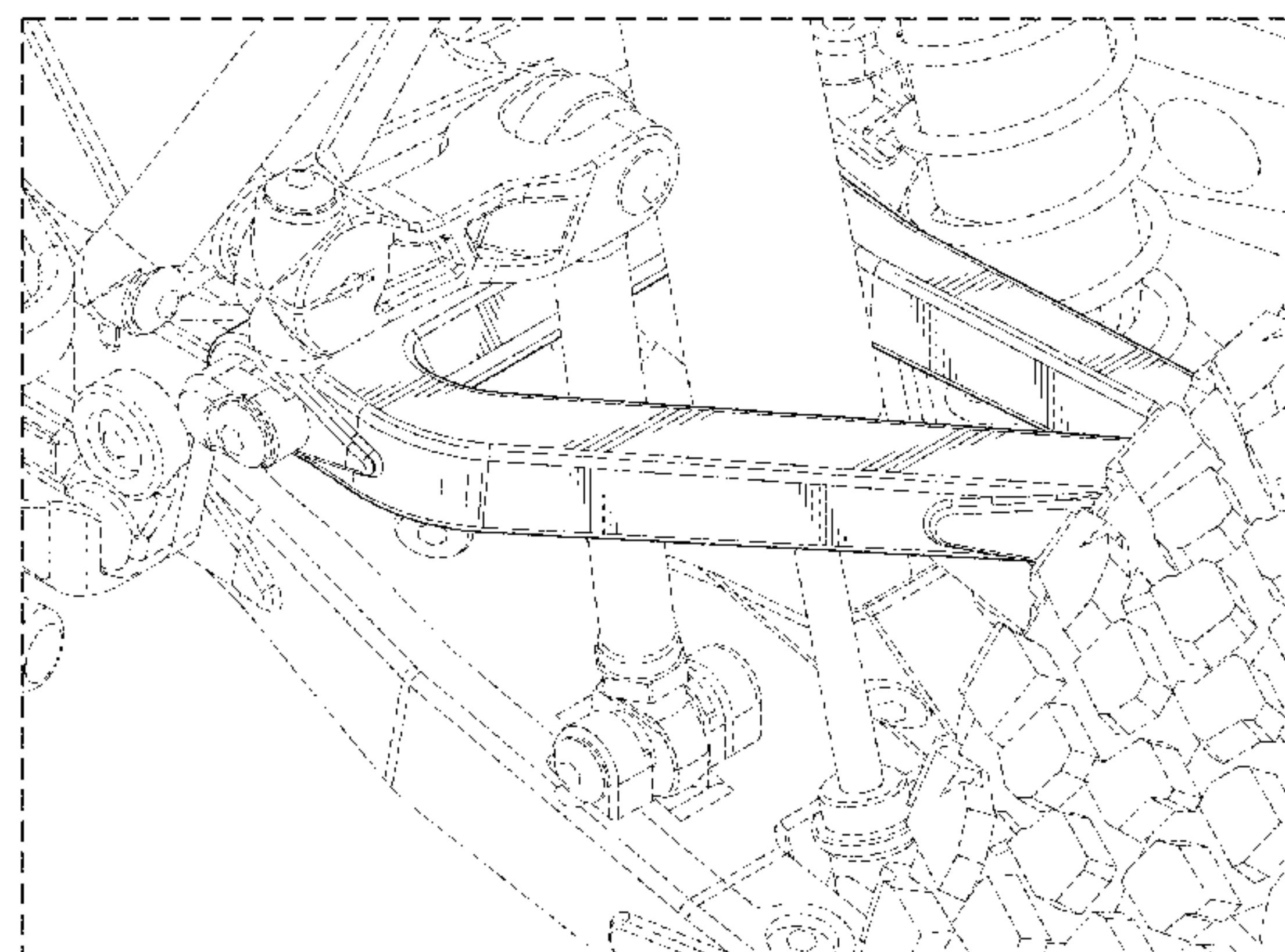
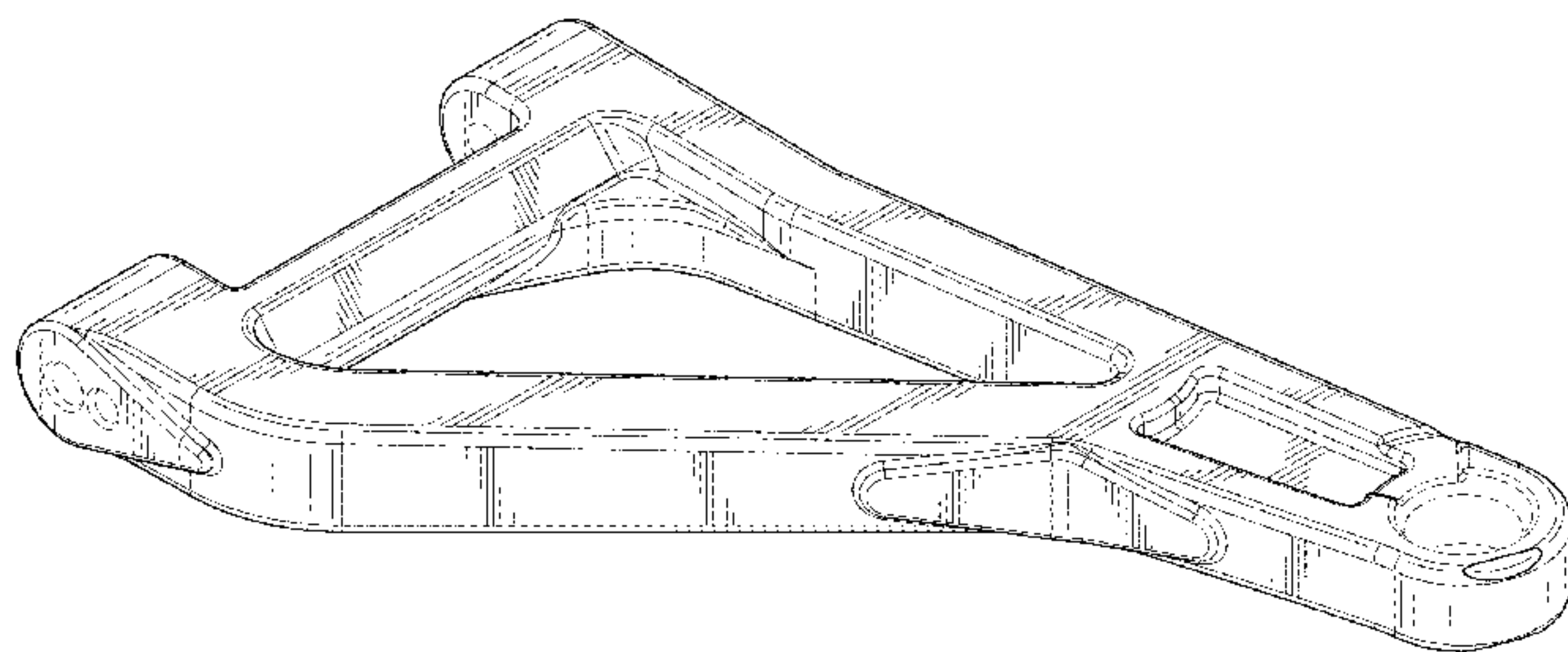



# US D875,186 S

<p>(58) <b>Field of Classification Search</b></p> <p>CPC ..... B60G 2200/1322; B60G 2200/14; B60G 2200/142; B60G 2200/1422; B60G 2200/1424; B60G 2200/1442; B60G 2200/156; B60G 2200/182; B60G 2200/22; B60G 2200/315</p> <p>See application file for complete search history.</p>	<table border="0" style="width: 100%;"> <tr><td style="width: 15%;">5,692,853</td><td style="width: 10%;">A</td><td style="width: 10%;">12/1997</td><td>Litz et al.</td></tr> <tr><td>5,774,984</td><td>A</td><td>7/1998</td><td>Kotani</td></tr> <tr><td>5,816,357</td><td>A</td><td>10/1998</td><td>Camlin</td></tr> <tr><td>5,839,742</td><td>A</td><td>11/1998</td><td>Holt</td></tr> <tr><td>5,845,926</td><td>A</td><td>12/1998</td><td>Davis et al.</td></tr> <tr><td>5,915,727</td><td>A *</td><td>6/1999</td><td>Bonnville ..... B60G 7/02 280/124.1</td></tr> <tr><td>5,934,696</td><td>A</td><td>8/1999</td><td>Bloser et al.</td></tr> <tr><td>5,938,219</td><td>A *</td><td>8/1999</td><td>Hayami ..... B60G 3/20 280/124.135</td></tr> </table>	5,692,853	A	12/1997	Litz et al.	5,774,984	A	7/1998	Kotani	5,816,357	A	10/1998	Camlin	5,839,742	A	11/1998	Holt	5,845,926	A	12/1998	Davis et al.	5,915,727	A *	6/1999	Bonnville ..... B60G 7/02 280/124.1	5,934,696	A	8/1999	Bloser et al.	5,938,219	A *	8/1999	Hayami ..... B60G 3/20 280/124.135																																																																																																																																																																																																																																				
5,692,853	A	12/1997	Litz et al.																																																																																																																																																																																																																																																																		
5,774,984	A	7/1998	Kotani																																																																																																																																																																																																																																																																		
5,816,357	A	10/1998	Camlin																																																																																																																																																																																																																																																																		
5,839,742	A	11/1998	Holt																																																																																																																																																																																																																																																																		
5,845,926	A	12/1998	Davis et al.																																																																																																																																																																																																																																																																		
5,915,727	A *	6/1999	Bonnville ..... B60G 7/02 280/124.1																																																																																																																																																																																																																																																																		
5,934,696	A	8/1999	Bloser et al.																																																																																																																																																																																																																																																																		
5,938,219	A *	8/1999	Hayami ..... B60G 3/20 280/124.135																																																																																																																																																																																																																																																																		
<p>(56) <b>References Cited</b></p> <p style="text-align: center;">U.S. PATENT DOCUMENTS</p>	<table border="0" style="width: 100%;"> <tr><td style="width: 15%;">5,992,863</td><td style="width: 10%;">A</td><td style="width: 10%;">11/1999</td><td>Forbes-Robinson et al.</td></tr> <tr><td>6,076,840</td><td>A</td><td>6/2000</td><td>Kincaid et al.</td></tr> <tr><td>6,142,268</td><td>A</td><td>11/2000</td><td>Kuo-An</td></tr> <tr><td>D435,236</td><td>S</td><td>12/2000</td><td>Hanlon et al.</td></tr> <tr><td>6,170,838</td><td>B1</td><td>1/2001</td><td>Laurent et al.</td></tr> <tr><td>6,206,392</td><td>B1</td><td>3/2001</td><td>Siecinski et al.</td></tr> <tr><td>6,478,655</td><td>B2</td><td>11/2002</td><td>Wu</td></tr> <tr><td>6,550,796</td><td>B2</td><td>4/2003</td><td>Behr</td></tr> <tr><td>D475,001</td><td>S *</td><td>5/2003</td><td>Roll ..... D12/159</td></tr> <tr><td>6,595,714</td><td>B2</td><td>7/2003</td><td>Moore</td></tr> <tr><td>6,641,457</td><td>B1</td><td>11/2003</td><td>Lai</td></tr> <tr><td>6,655,118</td><td>B1</td><td>12/2003</td><td>Thompson et al.</td></tr> <tr><td>6,668,779</td><td>B2</td><td>12/2003</td><td>Hendriksma et al.</td></tr> <tr><td>6,685,203</td><td>B1</td><td>2/2004</td><td>Bodin et al.</td></tr> <tr><td>6,698,963</td><td>B1</td><td>3/2004</td><td>Parker et al.</td></tr> <tr><td>6,702,307</td><td>B2</td><td>3/2004</td><td>Becker et al.</td></tr> <tr><td>6,719,313</td><td>B2</td><td>4/2004</td><td>Zadok</td></tr> <tr><td>6,752,411</td><td>B2</td><td>6/2004</td><td>Few</td></tr> <tr><td>6,761,372</td><td>B2</td><td>7/2004</td><td>Bryant</td></tr> <tr><td>6,767,021</td><td>B2</td><td>7/2004</td><td>Schnurpel</td></tr> <tr><td>6,881,122</td><td>B2</td><td>4/2005</td><td>Bloch et al.</td></tr> <tr><td>6,929,273</td><td>B2</td><td>8/2005</td><td>Dobson et al.</td></tr> <tr><td>6,932,366</td><td>B2</td><td>8/2005</td><td>Jones et al.</td></tr> <tr><td>6,945,843</td><td>B1</td><td>9/2005</td><td>Motosko</td></tr> <tr><td>6,968,931</td><td>B2</td><td>11/2005</td><td>Huisman</td></tr> <tr><td>7,152,866</td><td>B2</td><td>12/2006</td><td>Chalin et al.</td></tr> <tr><td>7,185,902</td><td>B1</td><td>3/2007</td><td>Lloyd</td></tr> <tr><td>7,367,573</td><td>B2</td><td>5/2008</td><td>Kudo et al.</td></tr> <tr><td>7,883,099</td><td>B2</td><td>2/2011</td><td>Byers et al.</td></tr> <tr><td>7,887,074</td><td>B2 *</td><td>2/2011</td><td>Byers ..... A63H 17/26 280/124.135</td></tr> <tr><td>8,549,752</td><td>B1 *</td><td>10/2013</td><td>Byers ..... B21D 53/28</td></tr> <tr><td>D785,513</td><td>S *</td><td>5/2017</td><td>Park ..... D12/159</td></tr> <tr><td>D788,653</td><td>S *</td><td>6/2017</td><td>Smith ..... D12/159</td></tr> <tr><td>D827,054</td><td>S *</td><td>8/2018</td><td>Ewing ..... D21/561</td></tr> <tr><td>10,266,025</td><td>B2 *</td><td>4/2019</td><td>Lorenz ..... B60G 11/27</td></tr> <tr><td>D852,095</td><td>S *</td><td>6/2019</td><td>Walter ..... D12/162</td></tr> <tr><td>D865,079</td><td>S *</td><td>10/2019</td><td>Ewing ..... D21/561</td></tr> <tr><td>10,435,075</td><td>B2 *</td><td>10/2019</td><td>Lorenz ..... B60G 3/18</td></tr> <tr><td>2002/0041076</td><td>A1</td><td>4/2002</td><td>Becker et al.</td></tr> <tr><td>2002/0077025</td><td>A1</td><td>6/2002</td><td>Wu</td></tr> <tr><td>2002/0125676</td><td>A1</td><td>9/2002</td><td>Bryant</td></tr> <tr><td>2003/0107198</td><td>A1</td><td>6/2003</td><td>VanDenBerg</td></tr> <tr><td>2003/0122336</td><td>A1</td><td>7/2003</td><td>Zadok</td></tr> <tr><td>2003/0209217</td><td>A1</td><td>11/2003</td><td>Hendriksma et al.</td></tr> <tr><td>2003/0227151</td><td>A1</td><td>12/2003</td><td>Schreiber et al.</td></tr> <tr><td>2004/0004335</td><td>A1</td><td>1/2004</td><td>Rudder et al.</td></tr> <tr><td>2004/0045518</td><td>A1</td><td>3/2004</td><td>Abe</td></tr> <tr><td>2004/0261739</td><td>A1</td><td>12/2004</td><td>Shimizuya</td></tr> <tr><td>2005/0040619</td><td>A1</td><td>2/2005</td><td>Melcher</td></tr> <tr><td>2005/0220535</td><td>A1</td><td>10/2005</td><td>Griffin</td></tr> <tr><td>2006/0006622</td><td>A1</td><td>1/2006</td><td>Gesmer et al.</td></tr> <tr><td>2006/0246819</td><td>A1 *</td><td>11/2006</td><td>Byers ..... A63H 17/262 446/431</td></tr> <tr><td>2016/0318362</td><td>A1 *</td><td>11/2016</td><td>Watanabe ..... B60G 3/04</td></tr> <tr><td>2017/0050483</td><td>A1 *</td><td>2/2017</td><td>Gordon ..... B60G 7/001</td></tr> <tr><td>2017/0050485</td><td>A1 *</td><td>2/2017</td><td>Eleazar ..... B60G 7/001</td></tr> <tr><td>2017/0274932</td><td>A1 *</td><td>9/2017</td><td>Byrnes, Jr. .... B60G 3/20</td></tr> <tr><td>2018/0065465</td><td>A1 *</td><td>3/2018</td><td>Ward ..... B60K 5/10</td></tr> <tr><td>2018/0326843</td><td>A1 *</td><td>11/2018</td><td>Danielson ..... F16H 57/035</td></tr> <tr><td>2018/0370310</td><td>A1 *</td><td>12/2018</td><td>Becker ..... B60G 3/20</td></tr> <tr><td>2019/0070919</td><td>A1 *</td><td>3/2019</td><td>Andou ..... B60G 3/202</td></tr> <tr><td>2019/0143871</td><td>A1 *</td><td>5/2019</td><td>Weber ..... B60P 1/04</td></tr> <tr><td>2019/0145465</td><td>A1 *</td><td>5/2019</td><td>Olason ..... F16D 3/223</td></tr> <tr><td>2019/0217894</td><td>A1 *</td><td>7/2019</td><td>Upah ..... B62D 21/155</td></tr> <tr><td>2019/0225042</td><td>A1 *</td><td>7/2019</td><td>Upah ..... B60G 3/207</td></tr> <tr><td>2019/0241035</td><td>A1 *</td><td>8/2019</td><td>Wolf-Monheim ..... B60G 3/06</td></tr> </table>	5,992,863	A	11/1999	Forbes-Robinson et al.	6,076,840	A	6/2000	Kincaid et al.	6,142,268	A	11/2000	Kuo-An	D435,236	S	12/2000	Hanlon et al.	6,170,838	B1	1/2001	Laurent et al.	6,206,392	B1	3/2001	Siecinski et al.	6,478,655	B2	11/2002	Wu	6,550,796	B2	4/2003	Behr	D475,001	S *	5/2003	Roll ..... D12/159	6,595,714	B2	7/2003	Moore	6,641,457	B1	11/2003	Lai	6,655,118	B1	12/2003	Thompson et al.	6,668,779	B2	12/2003	Hendriksma et al.	6,685,203	B1	2/2004	Bodin et al.	6,698,963	B1	3/2004	Parker et al.	6,702,307	B2	3/2004	Becker et al.	6,719,313	B2	4/2004	Zadok	6,752,411	B2	6/2004	Few	6,761,372	B2	7/2004	Bryant	6,767,021	B2	7/2004	Schnurpel	6,881,122	B2	4/2005	Bloch et al.	6,929,273	B2	8/2005	Dobson et al.	6,932,366	B2	8/2005	Jones et al.	6,945,843	B1	9/2005	Motosko	6,968,931	B2	11/2005	Huisman	7,152,866	B2	12/2006	Chalin et al.	7,185,902	B1	3/2007	Lloyd	7,367,573	B2	5/2008	Kudo et al.	7,883,099	B2	2/2011	Byers et al.	7,887,074	B2 *	2/2011	Byers ..... A63H 17/26 280/124.135	8,549,752	B1 *	10/2013	Byers ..... B21D 53/28	D785,513	S *	5/2017	Park ..... D12/159	D788,653	S *	6/2017	Smith ..... D12/159	D827,054	S *	8/2018	Ewing ..... D21/561	10,266,025	B2 *	4/2019	Lorenz ..... B60G 11/27	D852,095	S *	6/2019	Walter ..... D12/162	D865,079	S *	10/2019	Ewing ..... D21/561	10,435,075	B2 *	10/2019	Lorenz ..... B60G 3/18	2002/0041076	A1	4/2002	Becker et al.	2002/0077025	A1	6/2002	Wu	2002/0125676	A1	9/2002	Bryant	2003/0107198	A1	6/2003	VanDenBerg	2003/0122336	A1	7/2003	Zadok	2003/0209217	A1	11/2003	Hendriksma et al.	2003/0227151	A1	12/2003	Schreiber et al.	2004/0004335	A1	1/2004	Rudder et al.	2004/0045518	A1	3/2004	Abe	2004/0261739	A1	12/2004	Shimizuya	2005/0040619	A1	2/2005	Melcher	2005/0220535	A1	10/2005	Griffin	2006/0006622	A1	1/2006	Gesmer et al.	2006/0246819	A1 *	11/2006	Byers ..... A63H 17/262 446/431	2016/0318362	A1 *	11/2016	Watanabe ..... B60G 3/04	2017/0050483	A1 *	2/2017	Gordon ..... B60G 7/001	2017/0050485	A1 *	2/2017	Eleazar ..... B60G 7/001	2017/0274932	A1 *	9/2017	Byrnes, Jr. .... B60G 3/20	2018/0065465	A1 *	3/2018	Ward ..... B60K 5/10	2018/0326843	A1 *	11/2018	Danielson ..... F16H 57/035	2018/0370310	A1 *	12/2018	Becker ..... B60G 3/20	2019/0070919	A1 *	3/2019	Andou ..... B60G 3/202	2019/0143871	A1 *	5/2019	Weber ..... B60P 1/04	2019/0145465	A1 *	5/2019	Olason ..... F16D 3/223	2019/0217894	A1 *	7/2019	Upah ..... B62D 21/155	2019/0225042	A1 *	7/2019	Upah ..... B60G 3/207	2019/0241035	A1 *	8/2019	Wolf-Monheim ..... B60G 3/06
5,992,863	A	11/1999	Forbes-Robinson et al.																																																																																																																																																																																																																																																																		
6,076,840	A	6/2000	Kincaid et al.																																																																																																																																																																																																																																																																		
6,142,268	A	11/2000	Kuo-An																																																																																																																																																																																																																																																																		
D435,236	S	12/2000	Hanlon et al.																																																																																																																																																																																																																																																																		
6,170,838	B1	1/2001	Laurent et al.																																																																																																																																																																																																																																																																		
6,206,392	B1	3/2001	Siecinski et al.																																																																																																																																																																																																																																																																		
6,478,655	B2	11/2002	Wu																																																																																																																																																																																																																																																																		
6,550,796	B2	4/2003	Behr																																																																																																																																																																																																																																																																		
D475,001	S *	5/2003	Roll ..... D12/159																																																																																																																																																																																																																																																																		
6,595,714	B2	7/2003	Moore																																																																																																																																																																																																																																																																		
6,641,457	B1	11/2003	Lai																																																																																																																																																																																																																																																																		
6,655,118	B1	12/2003	Thompson et al.																																																																																																																																																																																																																																																																		
6,668,779	B2	12/2003	Hendriksma et al.																																																																																																																																																																																																																																																																		
6,685,203	B1	2/2004	Bodin et al.																																																																																																																																																																																																																																																																		
6,698,963	B1	3/2004	Parker et al.																																																																																																																																																																																																																																																																		
6,702,307	B2	3/2004	Becker et al.																																																																																																																																																																																																																																																																		
6,719,313	B2	4/2004	Zadok																																																																																																																																																																																																																																																																		
6,752,411	B2	6/2004	Few																																																																																																																																																																																																																																																																		
6,761,372	B2	7/2004	Bryant																																																																																																																																																																																																																																																																		
6,767,021	B2	7/2004	Schnurpel																																																																																																																																																																																																																																																																		
6,881,122	B2	4/2005	Bloch et al.																																																																																																																																																																																																																																																																		
6,929,273	B2	8/2005	Dobson et al.																																																																																																																																																																																																																																																																		
6,932,366	B2	8/2005	Jones et al.																																																																																																																																																																																																																																																																		
6,945,843	B1	9/2005	Motosko																																																																																																																																																																																																																																																																		
6,968,931	B2	11/2005	Huisman																																																																																																																																																																																																																																																																		
7,152,866	B2	12/2006	Chalin et al.																																																																																																																																																																																																																																																																		
7,185,902	B1	3/2007	Lloyd																																																																																																																																																																																																																																																																		
7,367,573	B2	5/2008	Kudo et al.																																																																																																																																																																																																																																																																		
7,883,099	B2	2/2011	Byers et al.																																																																																																																																																																																																																																																																		
7,887,074	B2 *	2/2011	Byers ..... A63H 17/26 280/124.135																																																																																																																																																																																																																																																																		
8,549,752	B1 *	10/2013	Byers ..... B21D 53/28																																																																																																																																																																																																																																																																		
D785,513	S *	5/2017	Park ..... D12/159																																																																																																																																																																																																																																																																		
D788,653	S *	6/2017	Smith ..... D12/159																																																																																																																																																																																																																																																																		
D827,054	S *	8/2018	Ewing ..... D21/561																																																																																																																																																																																																																																																																		
10,266,025	B2 *	4/2019	Lorenz ..... B60G 11/27																																																																																																																																																																																																																																																																		
D852,095	S *	6/2019	Walter ..... D12/162																																																																																																																																																																																																																																																																		
D865,079	S *	10/2019	Ewing ..... D21/561																																																																																																																																																																																																																																																																		
10,435,075	B2 *	10/2019	Lorenz ..... B60G 3/18																																																																																																																																																																																																																																																																		
2002/0041076	A1	4/2002	Becker et al.																																																																																																																																																																																																																																																																		
2002/0077025	A1	6/2002	Wu																																																																																																																																																																																																																																																																		
2002/0125676	A1	9/2002	Bryant																																																																																																																																																																																																																																																																		
2003/0107198	A1	6/2003	VanDenBerg																																																																																																																																																																																																																																																																		
2003/0122336	A1	7/2003	Zadok																																																																																																																																																																																																																																																																		
2003/0209217	A1	11/2003	Hendriksma et al.																																																																																																																																																																																																																																																																		
2003/0227151	A1	12/2003	Schreiber et al.																																																																																																																																																																																																																																																																		
2004/0004335	A1	1/2004	Rudder et al.																																																																																																																																																																																																																																																																		
2004/0045518	A1	3/2004	Abe																																																																																																																																																																																																																																																																		
2004/0261739	A1	12/2004	Shimizuya																																																																																																																																																																																																																																																																		
2005/0040619	A1	2/2005	Melcher																																																																																																																																																																																																																																																																		
2005/0220535	A1	10/2005	Griffin																																																																																																																																																																																																																																																																		
2006/0006622	A1	1/2006	Gesmer et al.																																																																																																																																																																																																																																																																		
2006/0246819	A1 *	11/2006	Byers ..... A63H 17/262 446/431																																																																																																																																																																																																																																																																		
2016/0318362	A1 *	11/2016	Watanabe ..... B60G 3/04																																																																																																																																																																																																																																																																		
2017/0050483	A1 *	2/2017	Gordon ..... B60G 7/001																																																																																																																																																																																																																																																																		
2017/0050485	A1 *	2/2017	Eleazar ..... B60G 7/001																																																																																																																																																																																																																																																																		
2017/0274932	A1 *	9/2017	Byrnes, Jr. .... B60G 3/20																																																																																																																																																																																																																																																																		
2018/0065465	A1 *	3/2018	Ward ..... B60K 5/10																																																																																																																																																																																																																																																																		
2018/0326843	A1 *	11/2018	Danielson ..... F16H 57/035																																																																																																																																																																																																																																																																		
2018/0370310	A1 *	12/2018	Becker ..... B60G 3/20																																																																																																																																																																																																																																																																		
2019/0070919	A1 *	3/2019	Andou ..... B60G 3/202																																																																																																																																																																																																																																																																		
2019/0143871	A1 *	5/2019	Weber ..... B60P 1/04																																																																																																																																																																																																																																																																		
2019/0145465	A1 *	5/2019	Olason ..... F16D 3/223																																																																																																																																																																																																																																																																		
2019/0217894	A1 *	7/2019	Upah ..... B62D 21/155																																																																																																																																																																																																																																																																		
2019/0225042	A1 *	7/2019	Upah ..... B60G 3/207																																																																																																																																																																																																																																																																		
2019/0241035	A1 *	8/2019	Wolf-Monheim ..... B60G 3/06																																																																																																																																																																																																																																																																		
<p>D46,086 S * 7/1914 Clark ..... D12/159</p> <p>1,135,577 A 4/1915 Hague</p> <p>1,647,438 A 11/1927 De Ram</p> <p>1,695,379 A 12/1928 Keck</p> <p>1,998,477 A 4/1935 Wikander</p> <p>2,123,681 A 7/1938 Willgoos</p> <p>2,126,085 A 8/1938 Balz</p> <p>2,131,661 A 9/1938 Heyermans et al.</p> <p>2,153,083 A 4/1939 Griswold</p> <p>2,186,065 A 1/1940 Fischer</p> <p>2,219,361 A 10/1940 Haberstump</p> <p>2,232,397 A 2/1941 Leighton</p> <p>2,264,174 A 11/1941 Crump et al.</p> <p>2,580,559 A 1/1952 Kolbe</p> <p>2,624,592 A 1/1953 Macpherson</p> <p>2,643,110 A 6/1953 Gregoire</p> <p>2,678,803 A 5/1954 Wilkerson</p> <p>2,776,147 A 1/1957 Bamford</p> <p>2,852,269 A 9/1958 Gaines</p> <p>2,913,253 A 11/1959 Taber</p> <p>2,931,663 A 4/1960 Ferand</p> <p>2,992,014 A 7/1961 Muller</p> <p>3,034,810 A 5/1962 Primean (Primeau)</p> <p>3,059,950 A 10/1962 Hedges</p> <p>3,177,004 A 4/1965 Schmidt</p> <p>3,231,040 A 1/1966 Blanchette</p> <p>3,410,575 A 11/1968 Tumbull et al.</p> <p>3,448,991 A 6/1969 Leggett</p> <p>3,545,125 A 12/1970 Okuma</p> <p>3,583,052 A 6/1971 Herbenar et al.</p> <p>3,591,198 A 7/1971 Brando</p> <p>3,632,127 A 1/1972 Grosseau</p> <p>3,671,694 A 6/1972 Masuda</p> <p>3,721,455 A 3/1973 Blanton</p> <p>3,727,938 A 4/1973 Goodbary et al.</p> <p>3,738,631 A 6/1973 Haley</p> <p>3,787,073 A 1/1974 Lievore</p> <p>3,938,822 A 2/1976 Guerriero</p> <p>D262,959 S 2/1982 Cowan</p> <p>4,470,611 A 9/1984 Duphily et al.</p> <p>D277,952 S 3/1985 Nakano et al.</p> <p>4,534,575 A 8/1985 Grove et al.</p> <p>4,546,997 A 10/1985 Smyers</p> <p>D281,772 S 12/1985 Heideman et al.</p> <p>4,706,989 A * 11/1987 Lijima ..... B60G 7/006 180/414</p> <p>4,786,075 A 11/1988 Takahashi</p> <p>4,807,901 A 2/1989 Kondo</p> <p>4,881,752 A 11/1989 Tanaka</p> <p>4,955,634 A 9/1990 Smith</p> <p>5,004,257 A * 4/1991 MacIsaac ..... B60G 21/00 180/299</p> <p>5,080,389 A 1/1992 Kawano et al.</p> <p>5,108,126 A 4/1992 Banse</p> <p>D335,851 S * 5/1993 Lofy ..... D12/159</p> <p>D337,555 S 7/1993 McNab et al.</p> <p>5,284,353 A 2/1994 Shinji et al.</p> <p>5,288,101 A 2/1994 Minnett</p> <p>5,332,255 A 7/1994 Velazquez</p> <p>5,516,130 A * 5/1996 Mitchell ..... B60G 3/20 280/124.134</p> <p>5,522,281 A 6/1996 Herman</p> <p>5,603,583 A 2/1997 Jackson</p> <p>D385,835 S * 11/1997 Webster ..... D12/159</p> <p>5,682,849 A 11/1997 Regueiro</p>																																																																																																																																																																																																																																																																					



(56)

**References Cited**

## U.S. PATENT DOCUMENTS

2019/0283516 A1\* 9/2019 Gordon ..... B60G 3/145  
 2019/0285131 A1\* 9/2019 Garrett ..... F16F 13/005

## FOREIGN PATENT DOCUMENTS

DE 202018103151 U1 \* 6/2018 ..... B60G 7/02  
 EP 0070025 A2 \* 1/1983 ..... B60G 3/145  
 EP -3271195 B1 \* 5/2019 ..... B60G 7/02  
 WO WO-2010066226 A1 \* 6/2010 ..... B60G 7/001

## OTHER PUBLICATIONS

CN-304110963, posted at Orbit.com, publication date Apr. 19, 2017. Site visited Apr. 12, 2019. Available from Internet. (Year: 2017).\*

ARTINCbydb, Traxxas E-Revo Upper/Lower Arm Replacement, posted at YouTube, posting date Feb. 4, 2013. Site visited Apr. 12, 2019. URL: <<https://www.youtube.com/watch?v=fGMtjrrezT0>> (Year: 2013).\*

Traxxas 5331 Right Front Upper & Lower Arms, posted at Amazon, review posted Dec. 30, 2014. Site visited Apr. 12, 2019. URL: <<https://www.amazon.com/Trwoms-Right-Front-Upper-Suspension/dp/B000BOPTOG>> (Year: 2014).\*

Associated Electrics, “Monster GT” model truck; Associated Electrics, Inc., Costa Mesa, California, 1 photograph (admitted prior art).

Associated Electrics, “RC10GT” model vehicle; Associated Electrics, Inc., Costa Mesa, California, 1 photograph (admitted prior art).

Bradley, John; “The Racing Motorcycle”; 1996, pp. 246-273, 322-325; Broadland Leisure Publications, England.

Ellsworth, Tony; “Suspension Design Enhancements—The Ellsworth Dare”; Dreamride Mountain Bike Tours and Film Services, Moab, Utah, 2001.

Horizon Hobby, “Losi XXX buggy”; Horizon Hobby, Inc., Champaign, Illinois; 1 sketch of suspension geometry (admitted prior art).

HPI Racing, “Savage 21” model truck; Hobby Products International, Foothill Ranch, California; 1 sketch of suspension geometry (admitted prior art).

Hyperpro\_USA; “What is Progressive Suspension?” HyperPRO\_USA.com (admitted prior art).

Kyosho Inferno MP7.5 model car; Kyosho America, Lake Forest, California; 2 sketches of suspension geometry (admitted prior art).

Milliken, William F. and Milliken, Douglas L.; “Race Car Vehicle Dynamics” 1995, pp. 580-583, 595-597, 628-631; SAE Publications Group, Pennsylvania USA.

Phillipotts, Peter; “Rising Rate Suspension”; Off Road Design, 2001. Race Tech, “Profile—Chalmers Formula SAE Car” Race Tech magazine, Oct./Nov. 2003, p. 74; Racecar Graphic Ltd, London, England.

Racecar Engineering, Jun. 2003—vol. 13 No. 06, pp. 15, 106; Country & Leisure Media Ltd./IPC Media Ltd., Croydon, England. Salven, Michael; “Progressive Suspension” Nov. 10, 2000; myTSN—Publication, Netherlands.

Serpent, Veteq; Serpent Model Racing Cars, Noord-Holland, Netherlands; 3 pictures (admitted prior art).

Serpent, Veteq; Serpent Model Racing Cars, Noord-Holland, Netherlands; 1 sketch of suspension geometry (admitted prior art).

Staniforth, Allan; “Competition Car Suspension” 1988, pp. 76-81, 84-85; Haynes Publications, Newbury Park, California.

Tamiya, “Terra Crusher” model truck; Tamiya America, Inc., Aliso Viejo, California; 1 sketch of suspension geometry (admitted prior art).

Traxxas LP; “T-Maxx Assemblies, Front Assembly” exploded view; Traxxas LP, Plano, Texas; (admitted prior art).

Traxxas, “Nitro Rustler” model vehicle; Traxxas LP, Plano, Texas; 1 photograph (admitted prior art).

Traxxas, “T-Maxx” model vehicle; Traxxas LP, Plano, Texas; 1 photograph (admitted prior art).

Full size vehicle with suspension linkage #1 (admitted prior art).

Full size vehicle with suspension linkage #2 (admitted prior art).

Chassis Shop, “Tube Adapters” Catalog pp. 46-51, Chassis Shop Performance Products, Mears, MI, USA. (admitted prior art).

Coleman Racing, “Hex Trailing Arm” web pages: [http://www.colemanracing.com/catalog/index.php?cPath=49\\_1024](http://www.colemanracing.com/catalog/index.php?cPath=49_1024) [http://www.colemanracing.com/catalog/product\\_info.php?cPath=49\\_1024&products\\_id=4714](http://www.colemanracing.com/catalog/product_info.php?cPath=49_1024&products_id=4714) Coleman Racing, Memominee, MI, USA. (admitted prior art).

Traxxas, “T-Maxx Rear Assembly” exploded view drawing; Traxxas LP, Plano, TX, USA. (admitted prior art).

Aerosticks, “What Are They” web page article, Dec. 26, 2004, DPD Enterprises, Ventura, CA, USA.

Aerosticks, “Fabrication” web page article, Dec. 26, 2004, DPD Enterprises, Ventura, CA, USA.

Aerosticks, “Design Basis” web page article, Jun. 7, 2004, DPD Enterprises, Ventura, CA, USA.

Aerosticks, 2 pages photographs, DPD Enterprises, Ventura, CA, USA. (admitted prior art).

\* cited by examiner

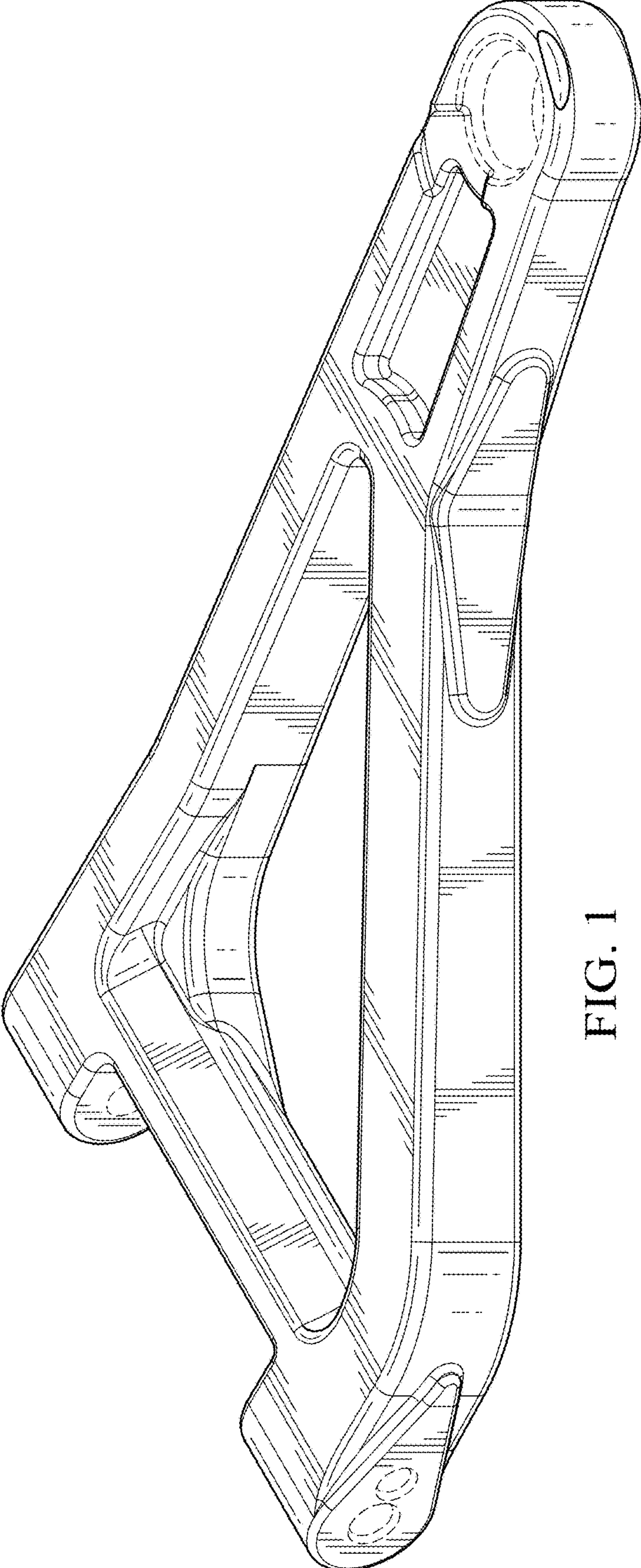

FIG. 1

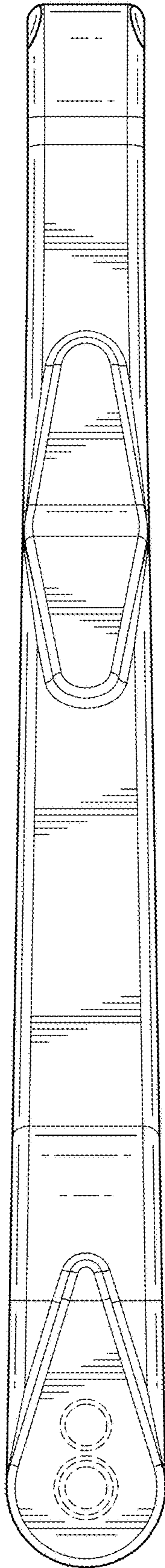

FIG. 2

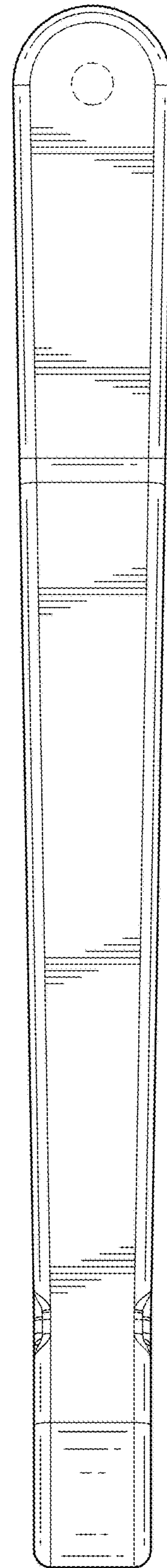

FIG. 3



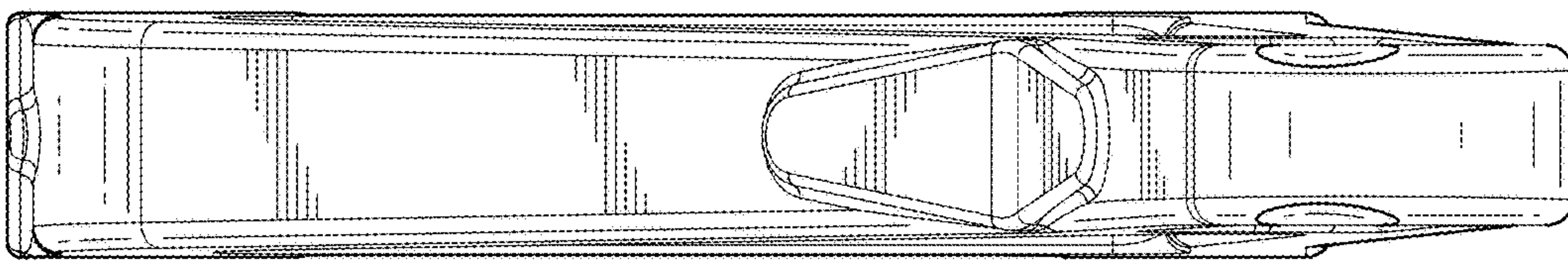

FIG. 4

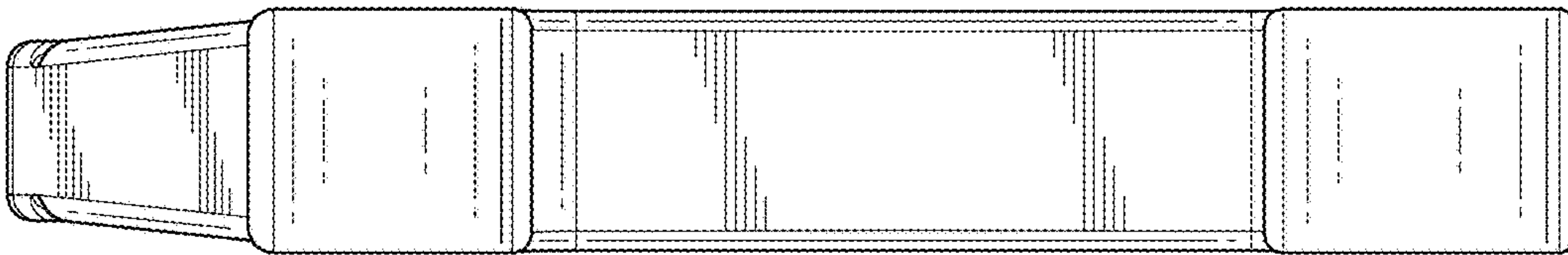

FIG. 5

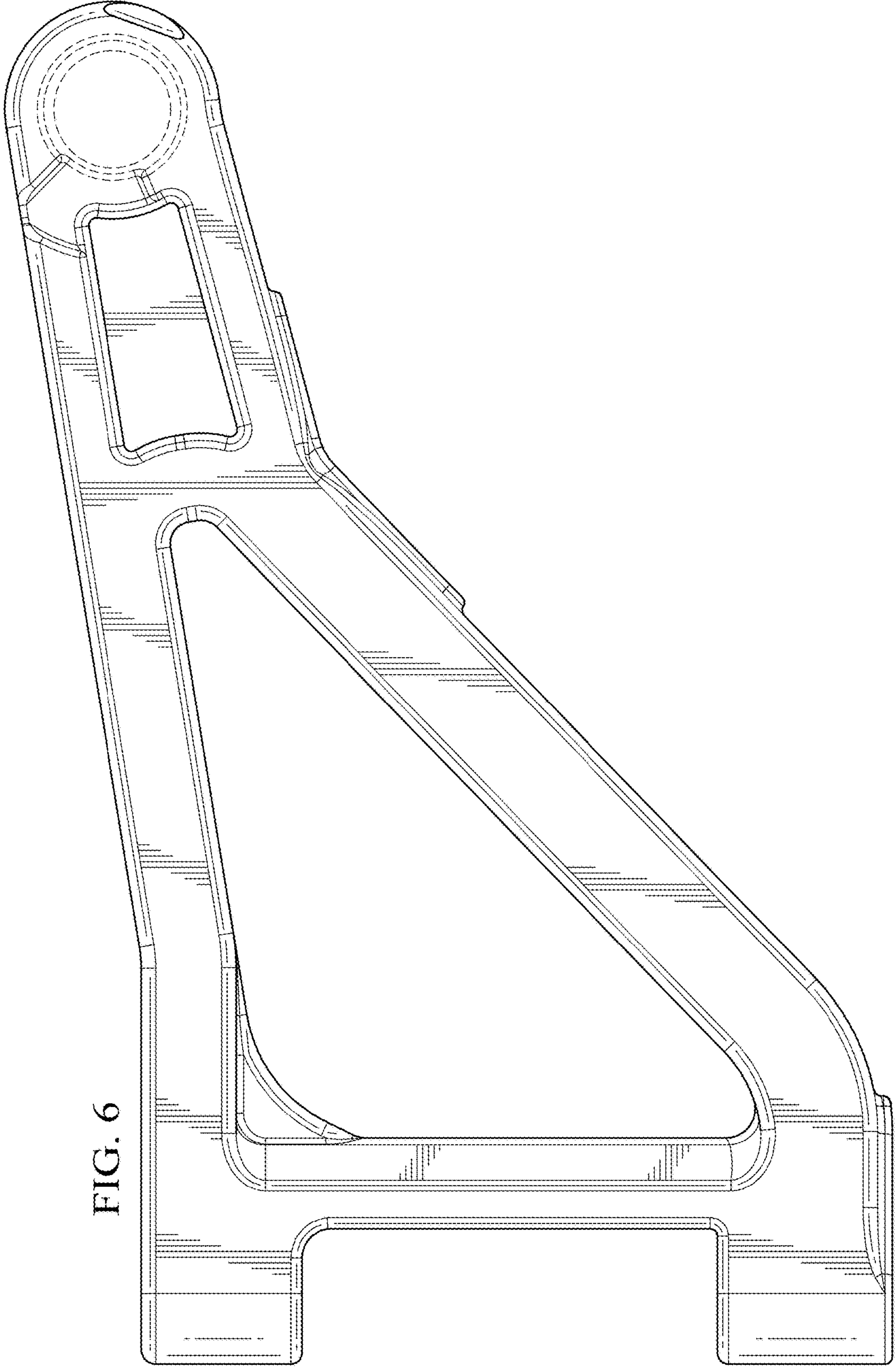

FIG. 6

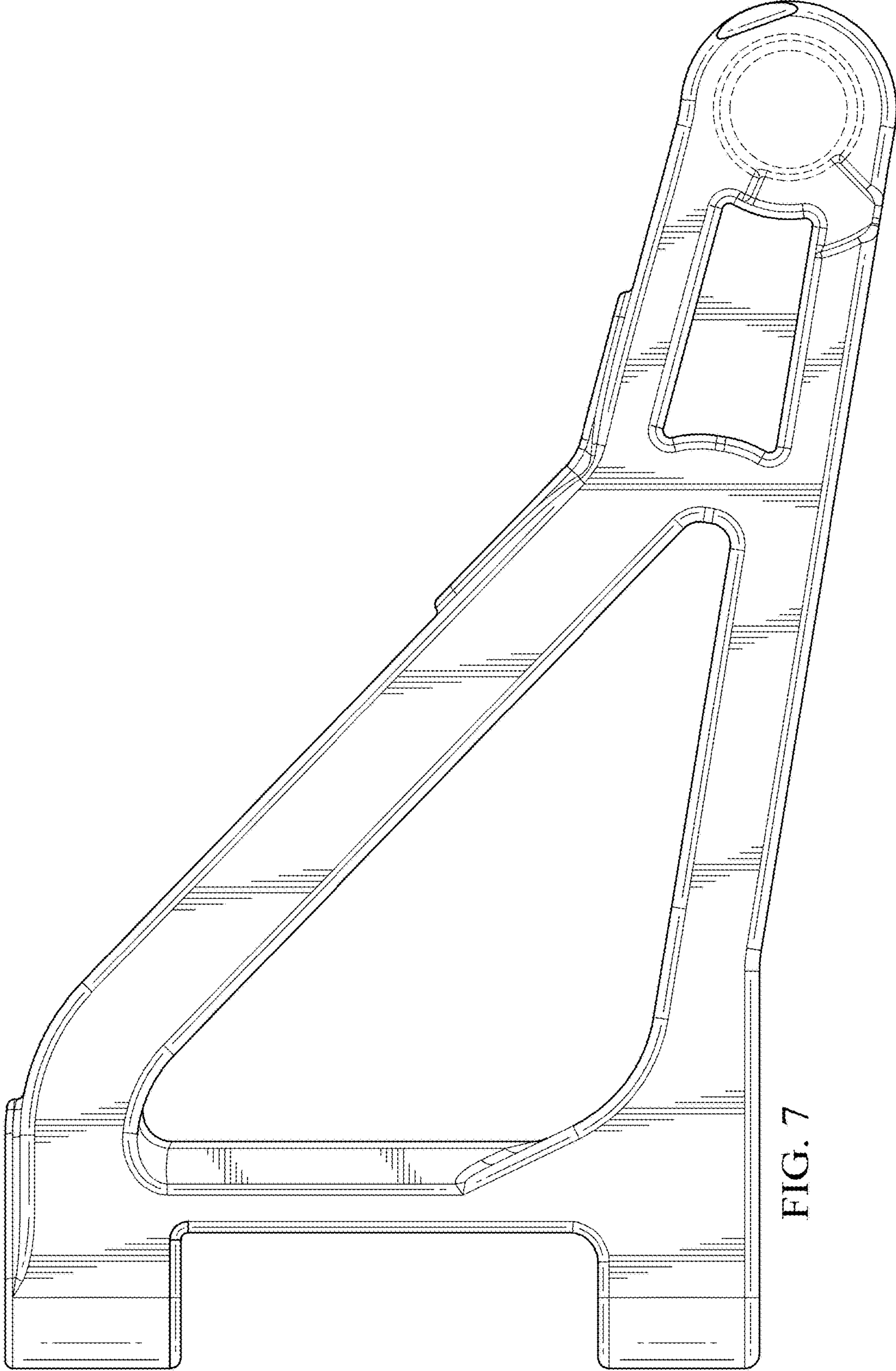

FIG. 7



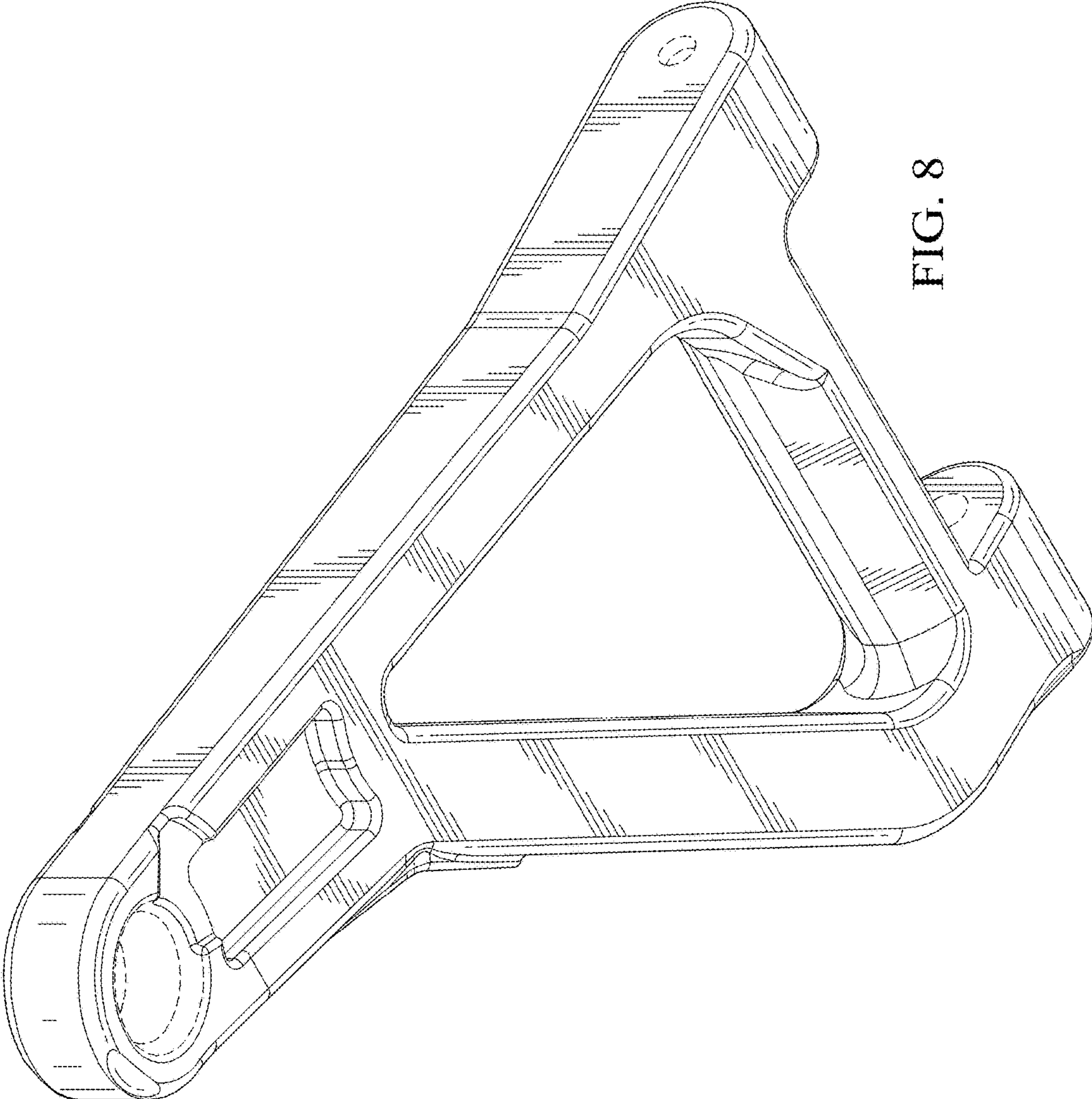

FIG. 8

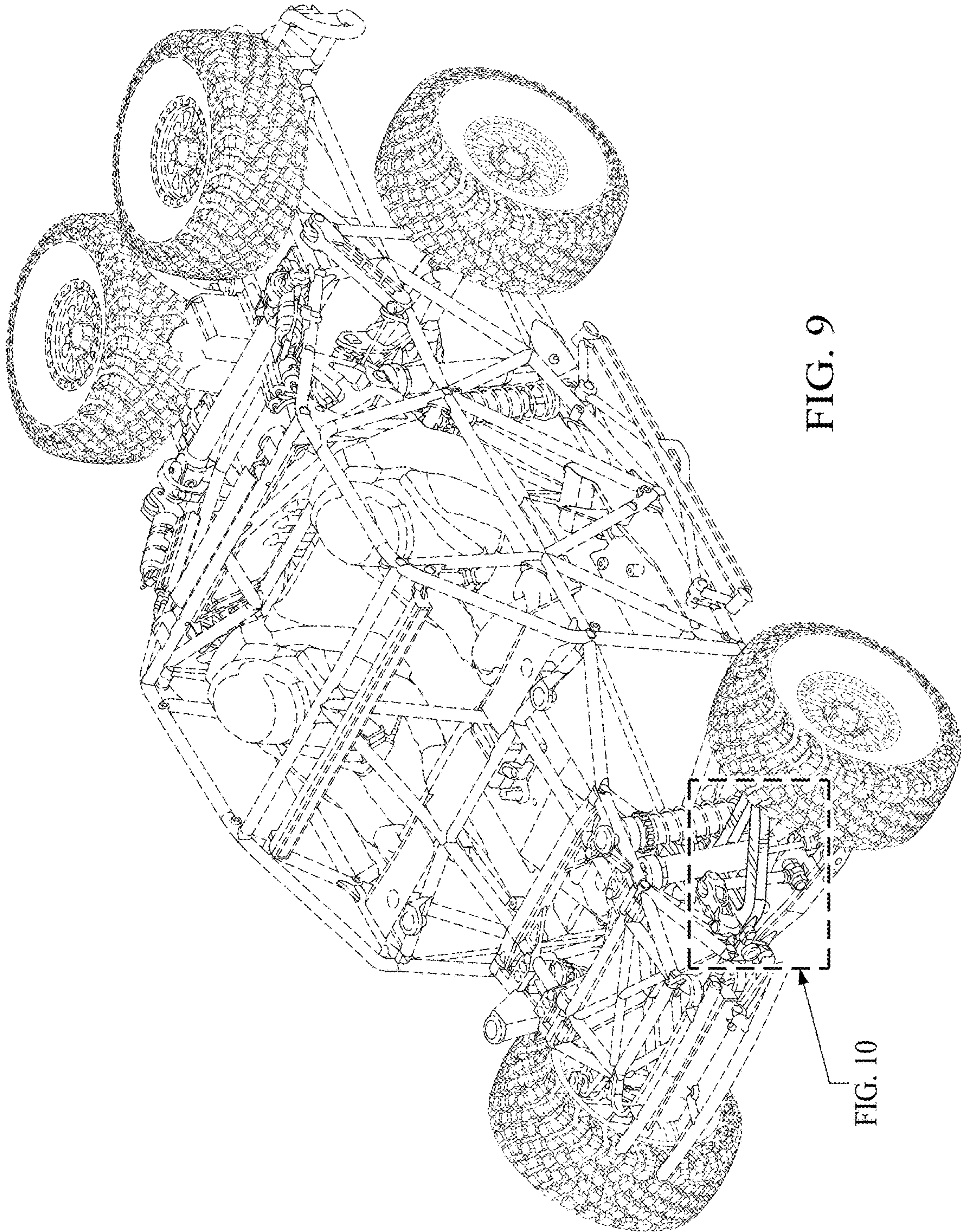

FIG. 9

FIG. 10



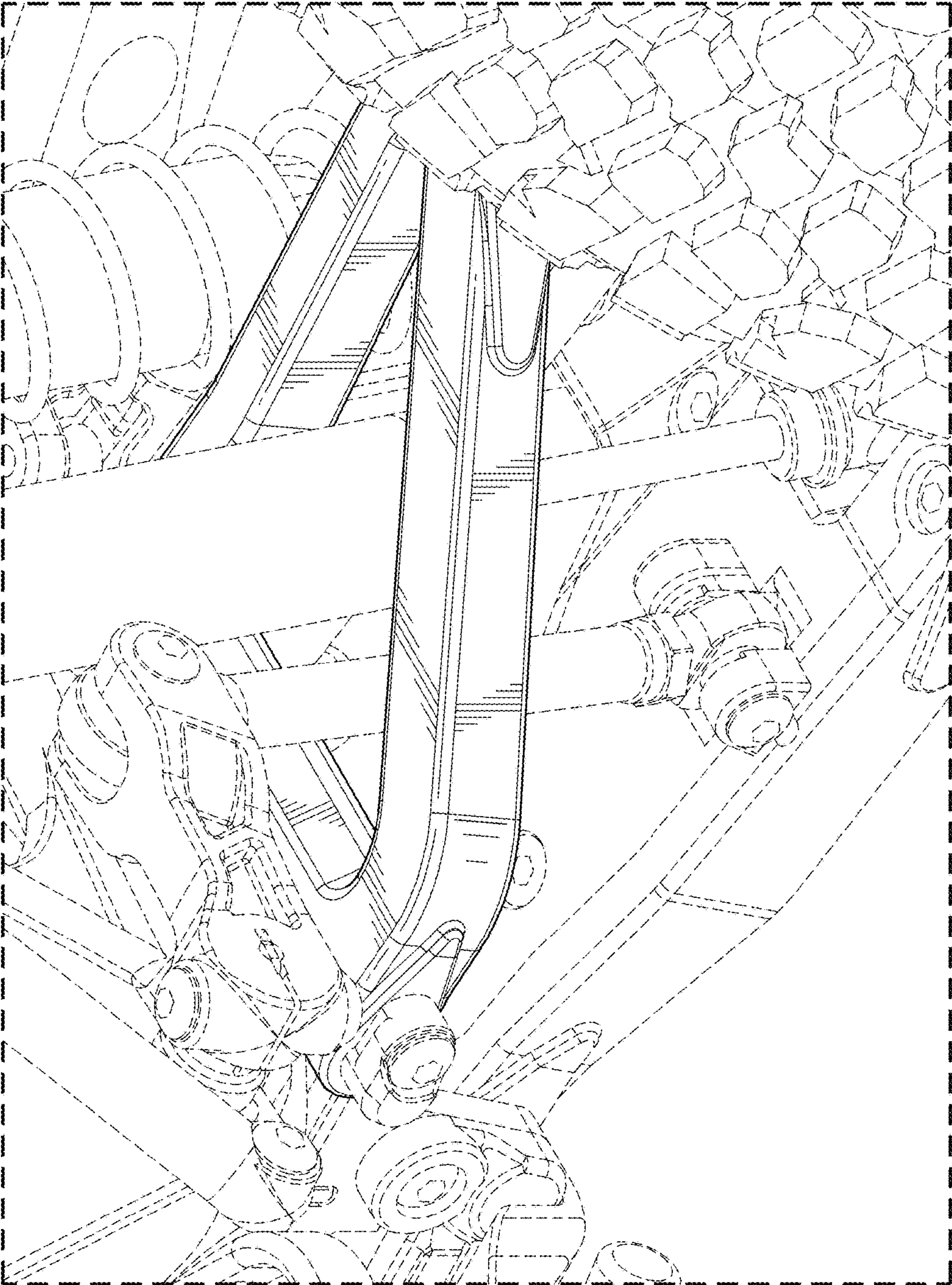

FIG. 10