



US00D874855S

(12) **United States Design Patent** (10) **Patent No.:** **US D874,855 S**
Wilfer (45) **Date of Patent:** **** *Feb. 11, 2020**

(54) **MULTIPLE GUITAR STAND**

(71) Applicant: **Warwick GmbH & Co. Music Equipment KG**, Markneukirchen (DE)

(72) Inventor: **Hans-Peter Wilfer**, Markneukirchen (DE)

(73) Assignee: **WARWICK GMBH & CO. MUSIC EQUIPMENT KG**, Markneukirchen (DE)

(*) Notice: This patent is subject to a terminal disclaimer.

(**) Term: **15 Years**

(21) Appl. No.: **29/654,649**

(22) Filed: **Jun. 26, 2018**

(30) **Foreign Application Priority Data**

Jan. 19, 2018 (EM) 004672426

(51) **LOC (12) Cl.** **06-06**

(52) **U.S. Cl.**
USPC **D6/682**

(58) **Field of Classification Search**
USPC D6/672-673, 678, 680, 682, 682.3;
D17/9, 20; D14/229, 447

(Continued)

(56) **References Cited**

U.S. PATENT DOCUMENTS

D44,078 S * 5/1913 Treadway 211/65
2,058,184 A * 10/1936 Sherrard G10G 5/00
211/20

(Continued)

Primary Examiner — Kelley A Donnelly

(74) *Attorney, Agent, or Firm* — Scarinci Hollenbeck, LLC; Libby Babu Varghese

(57) **CLAIM**

The ornamental design for a multiple guitar stand, as shown and described.

DESCRIPTION

FIG. 1 is a perspective view of a multiple guitar stand in the extended position;
FIG. 2 is a left-side view of a multiple guitar stand in the extended position;
FIG. 3 is a right-side view of a multiple guitar stand in the extended position;
FIG. 4 is a top view of a multiple guitar stand in the extended position;
FIG. 5 is a back view of a multiple guitar stand in the extended position;
FIG. 6 is a front view of a multiple guitar stand in the extended position;
FIG. 7 is a bottom view of a multiple guitar stand in the extended position;
FIG. 8 is a perspective view of a multiple guitar stand in the retracted position;
FIG. 9 is a left-view of a multiple guitar stand in the retracted position;
FIG. 10 is a right-view of a multiple guitar stand in the retracted position;
FIG. 11 is a top view of a multiple guitar stand in the retracted position;
FIG. 12 is a back view of a multiple guitar stand in the retracted position;
FIG. 13 is a front view of a multiple guitar stand in the retracted position; and,
FIG. 14 is a bottom view of a multiple guitar stand in the retracted position.

The elements shown in broken lines do not form any part of the claimed design. The break lines shown in FIGS. 1, 4, 5, 6, 7, 8, 11, 12, 13, and 14 are not part of the claimed design and represent that no particular length is claimed.

1 Claim, 14 Drawing Sheets

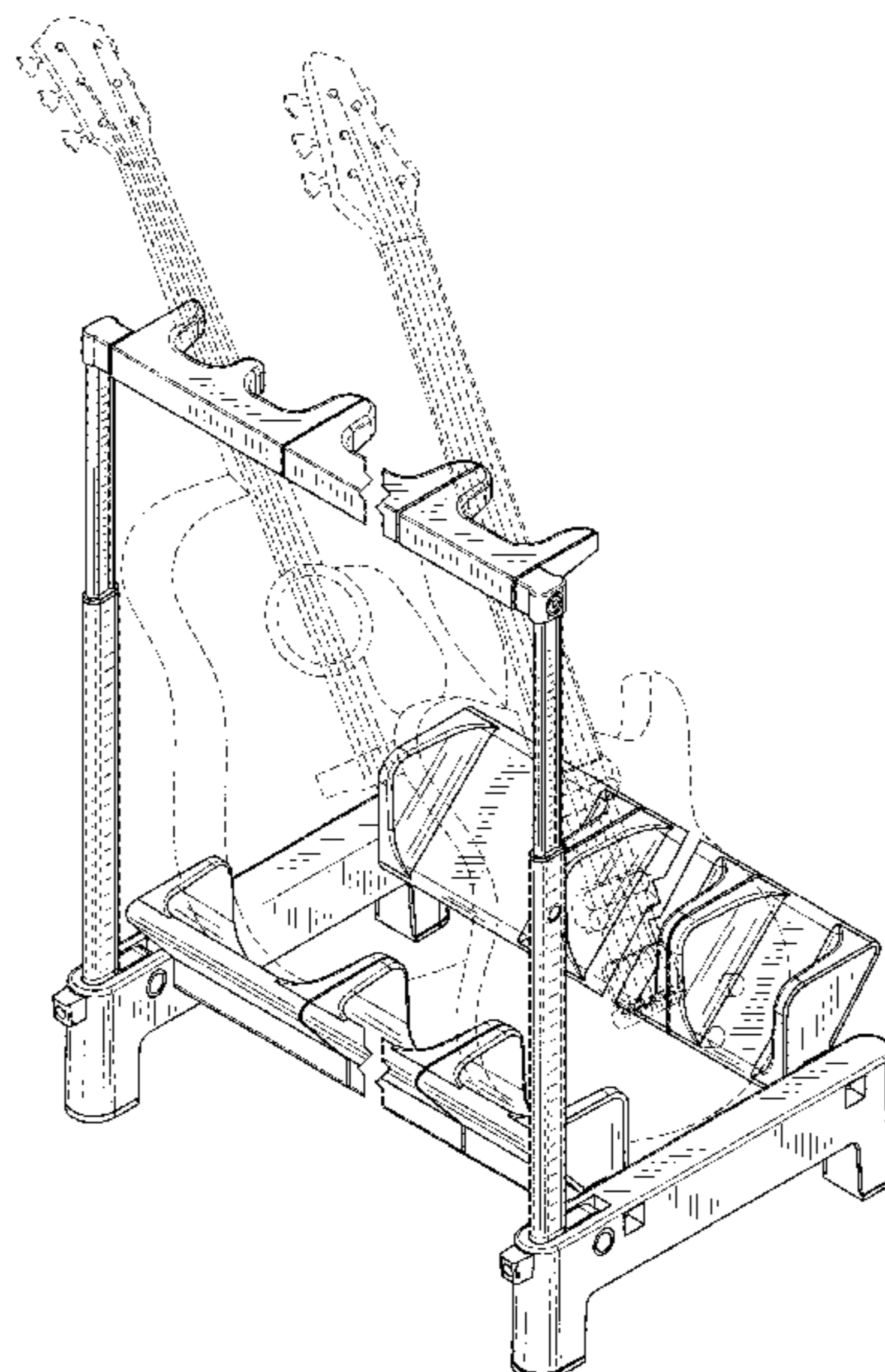

(58) **Field of Classification Search**

CPC A47F 7/00; A47F 7/0021; A47F 7/0042;
 A47B 23/004; A47B 19/002; G01G 5/00

See application file for complete search history.

(56) **References Cited**

U.S. PATENT DOCUMENTS

D162,207	S	*	2/1951	Mettenleiter	211/64
3,550,786	A	*	12/1970	Brown	A47F 5/12
						211/189
D278,670	S	*	5/1985	Schoenig	D6/681.1
D288,509	S	*	3/1987	van de Oudeweetering	
						D6/682
D295,814	S	*	5/1988	Chang	D6/682
D361,012	S	*	8/1995	Dardashti	D6/407
D361,917	S	*	9/1995	Dardashti	D6/407
D375,003	S	*	10/1996	Nordstrom, Jr.	D17/99
D392,123	S	*	3/1998	Lynch	D17/99
D407,240	S	*	3/1999	Payne	D17/99
6,296,213	B1	*	10/2001	Law, III	G10G 5/00
						206/45.2
D464,508	S	*	10/2002	Wilfer	D6/552
D538,554	S	*	3/2007	Tai	D6/682
D650,611	S	*	12/2011	Melhart	D6/682.4
D679,117	S	*	4/2013	Werner	D6/682.4
8,770,535	B1	*	7/2014	Yu	G10G 5/00
						211/85.6
D758,769	S	*	6/2016	Terpening	D6/682
D782,227	S	*	3/2017	Hepburn	D6/674
D782,554	S	*	3/2017	Karsten	D16/131
D827,344	S	*	9/2018	Dillon	D6/682
2009/0184074	A1	*	7/2009	Jacobson	A47B 81/00
						211/85.6

* cited by examiner

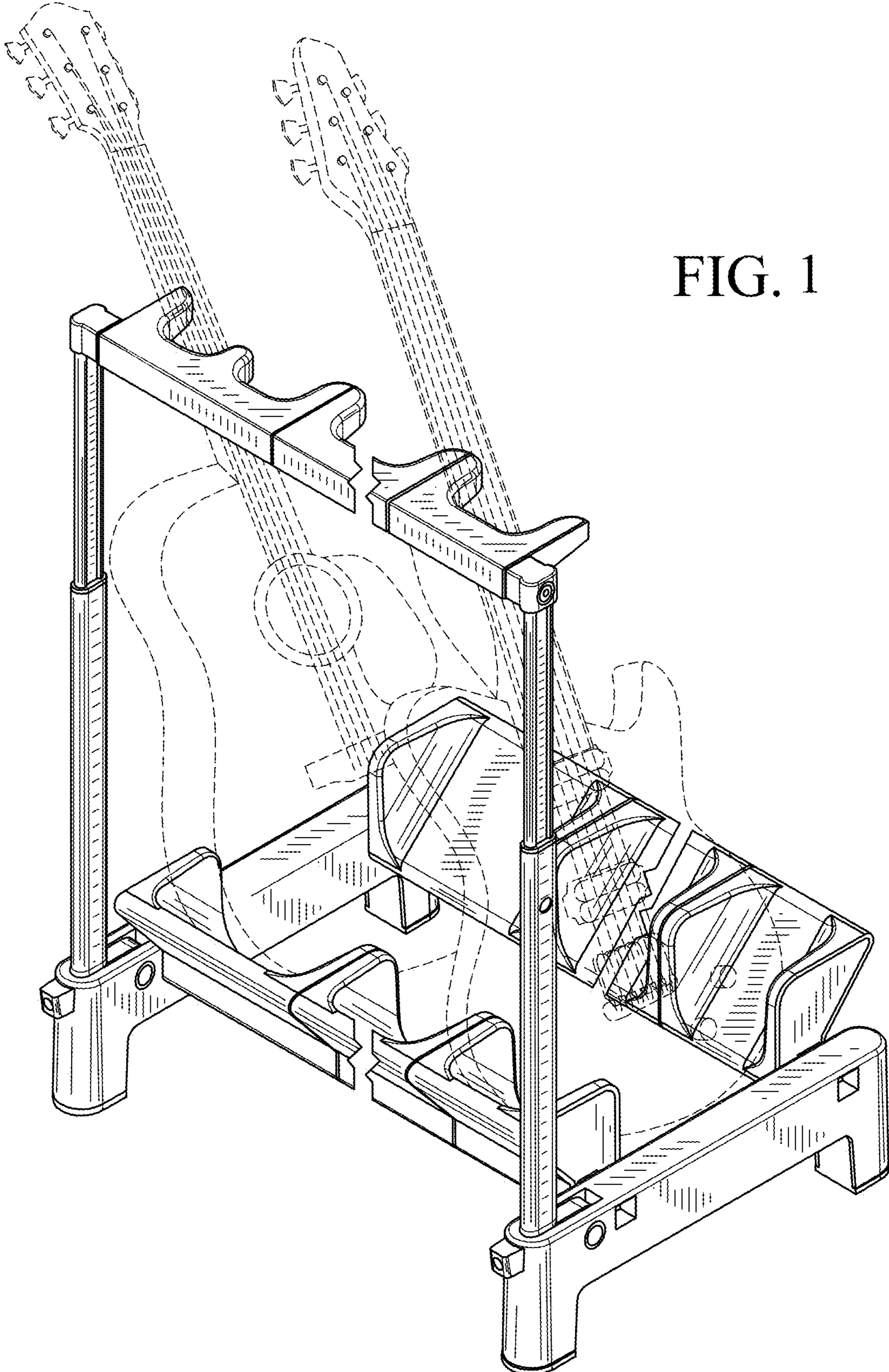

FIG. 1

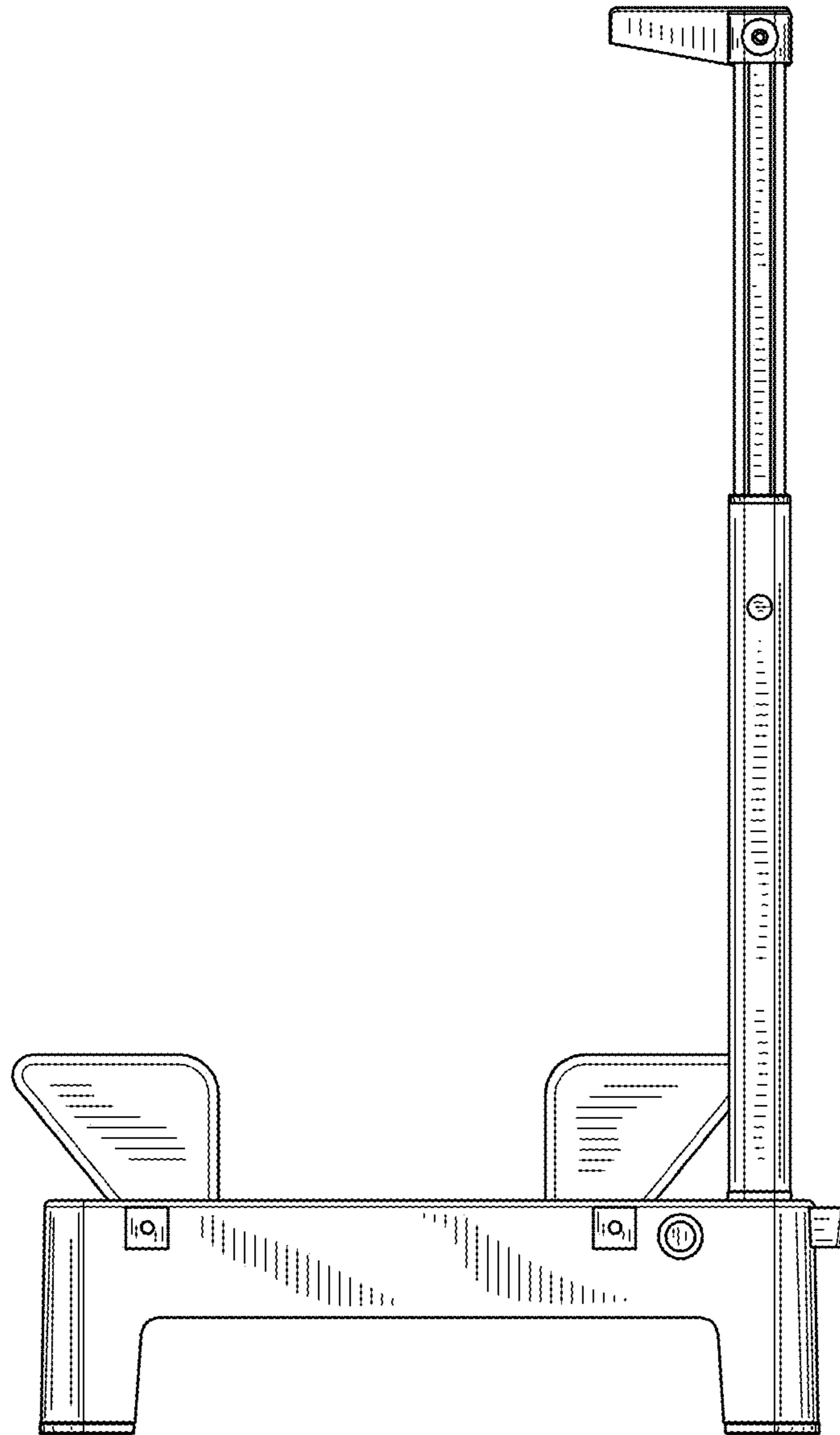

FIG. 2

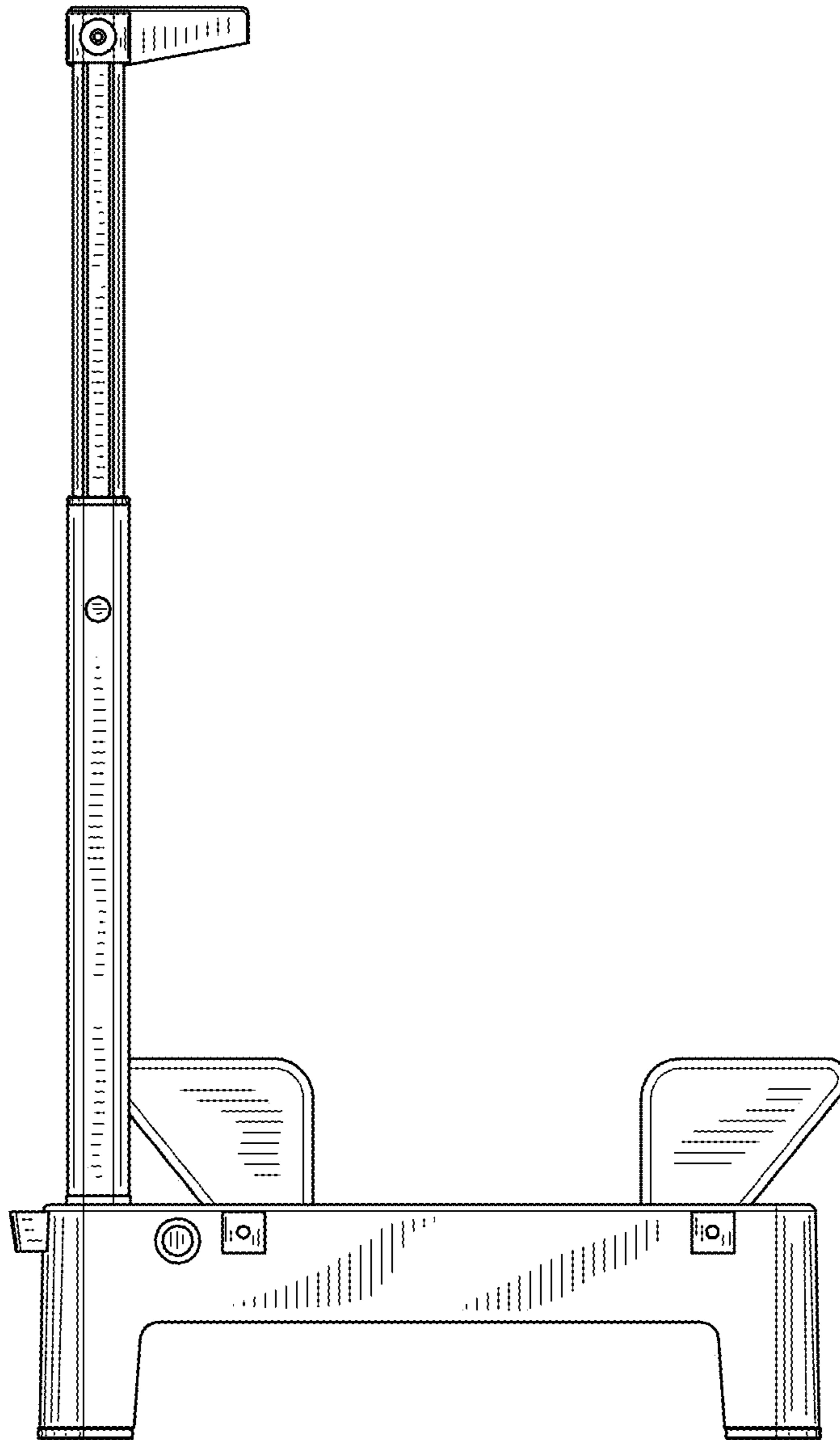

FIG. 3

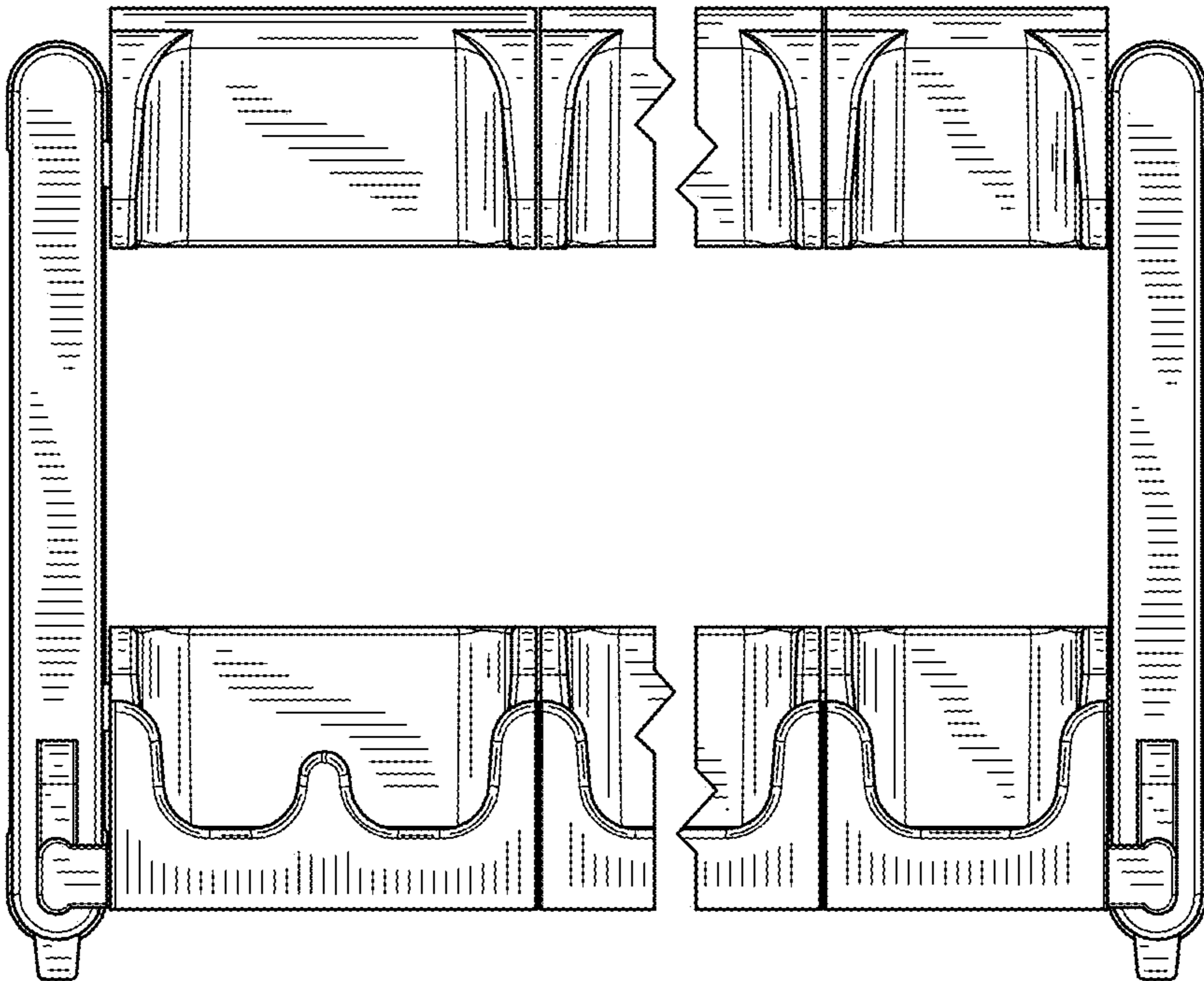

FIG. 4

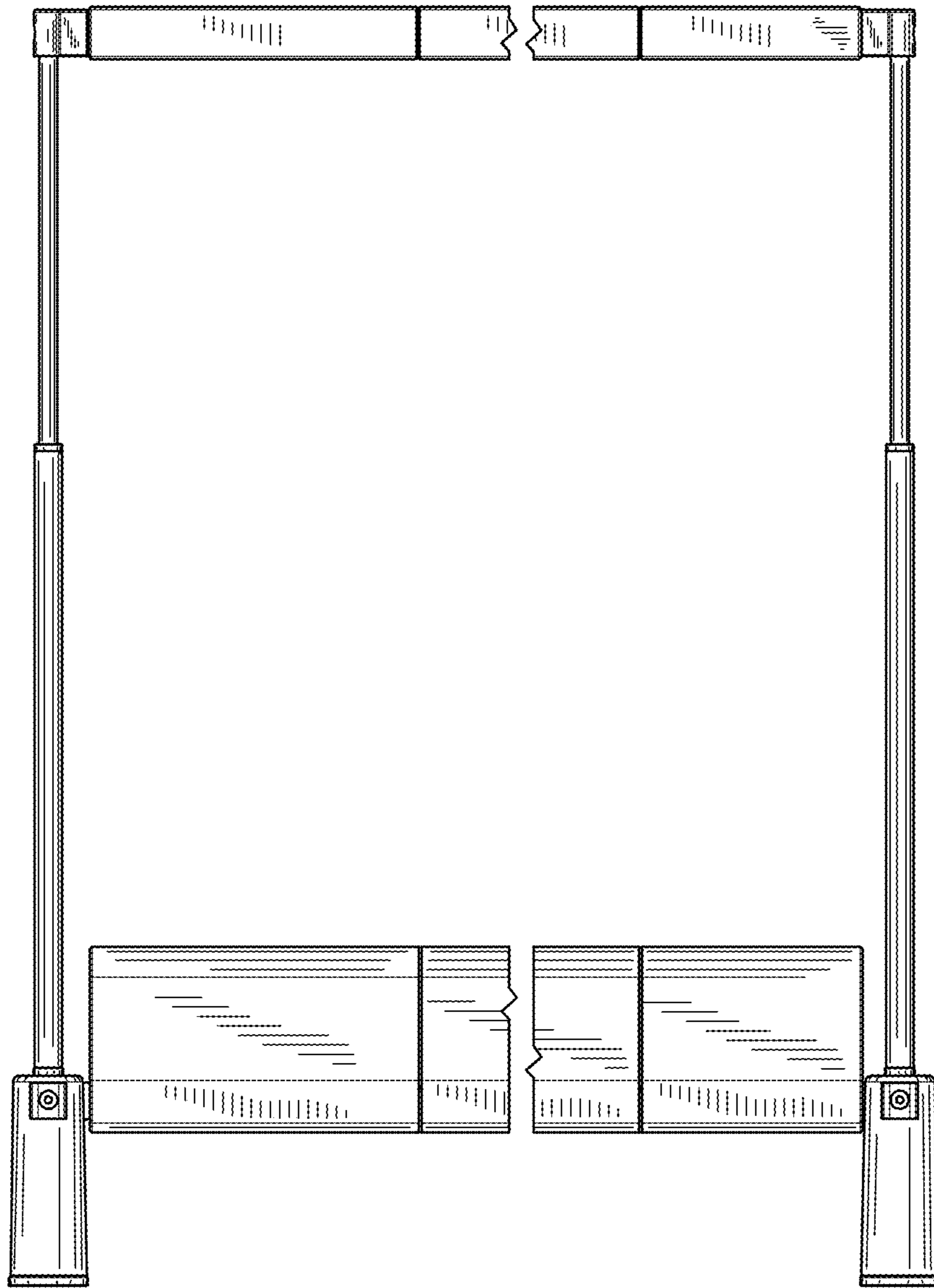

FIG. 5

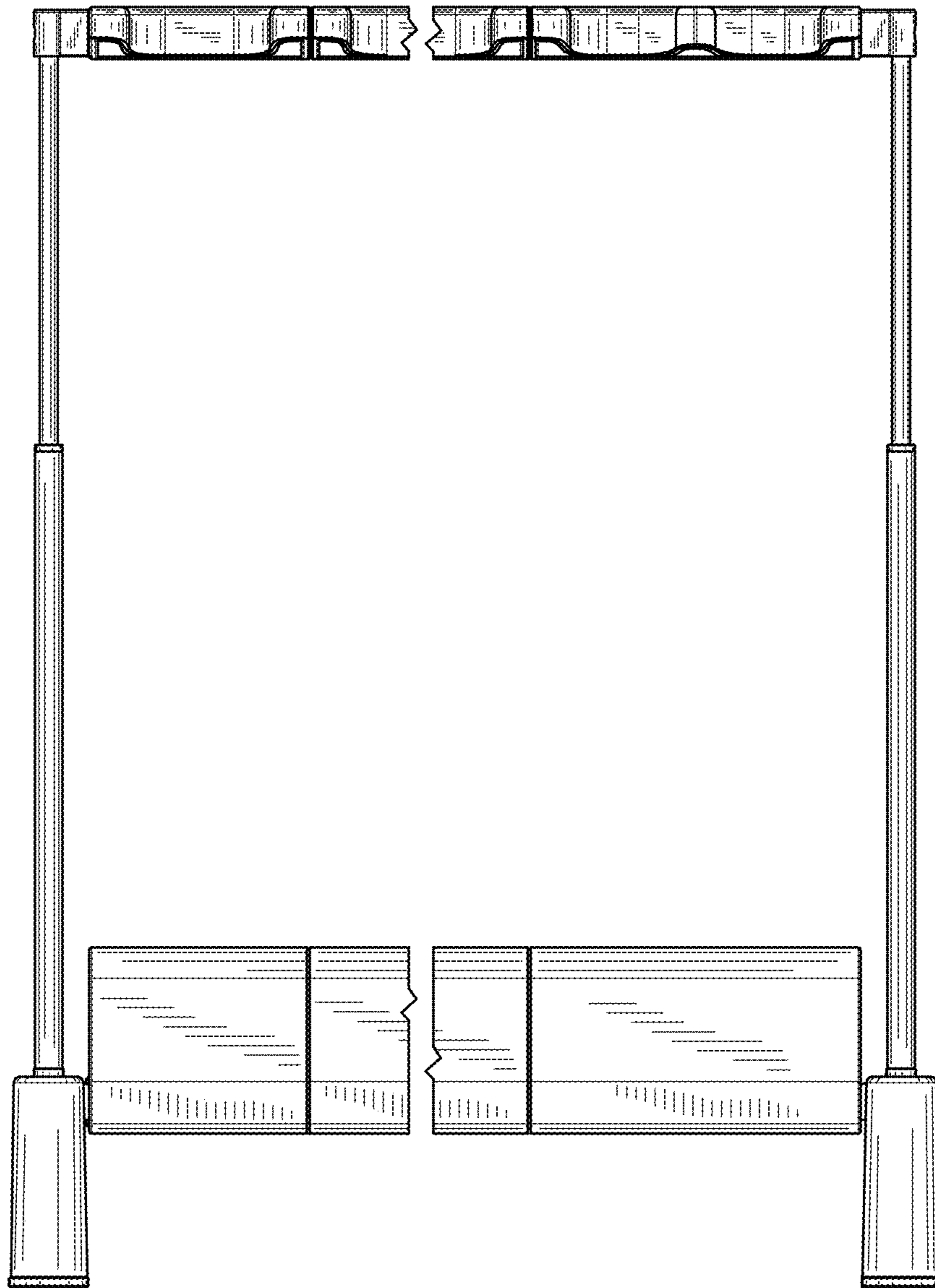

FIG. 6

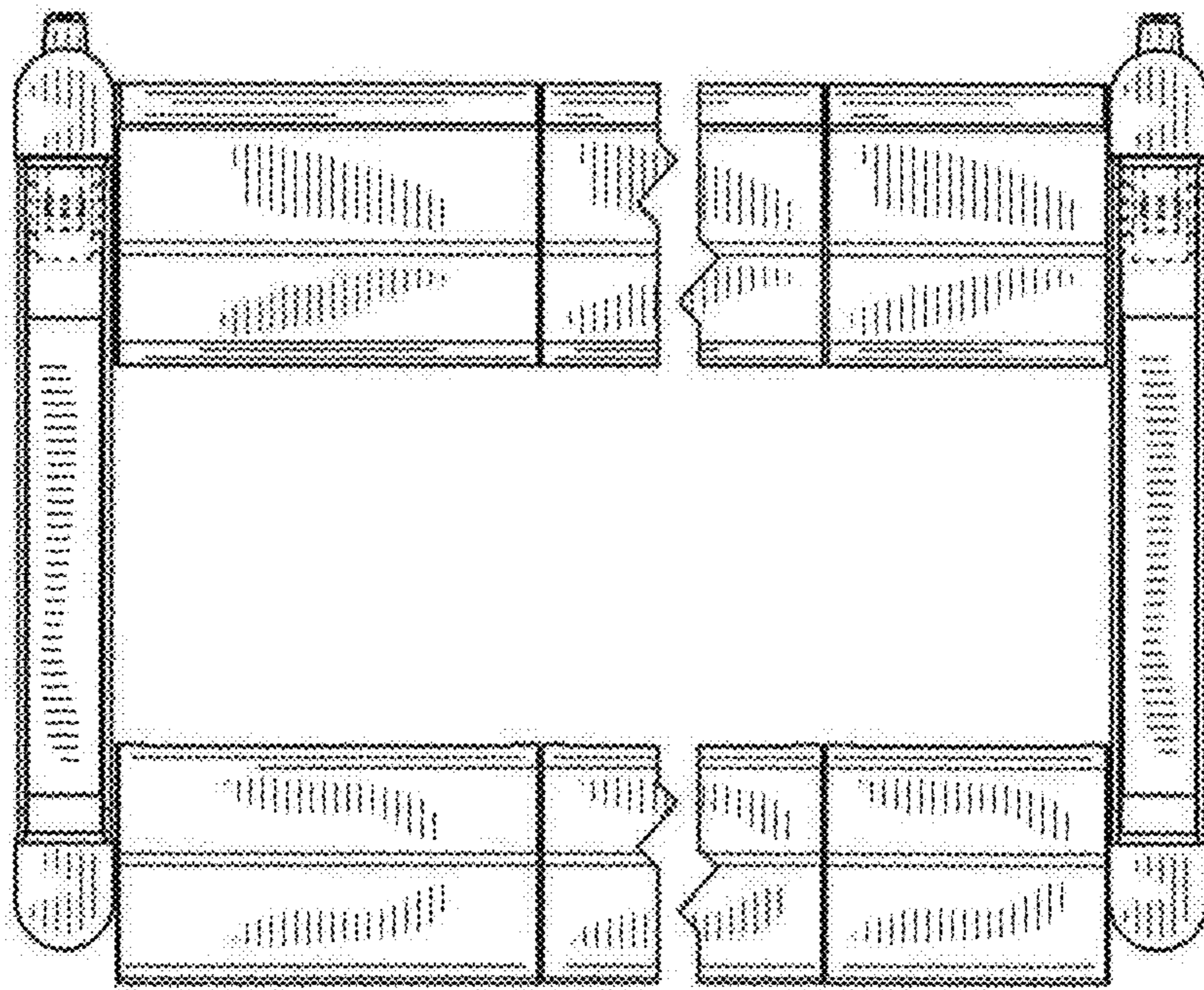

FIG. 7

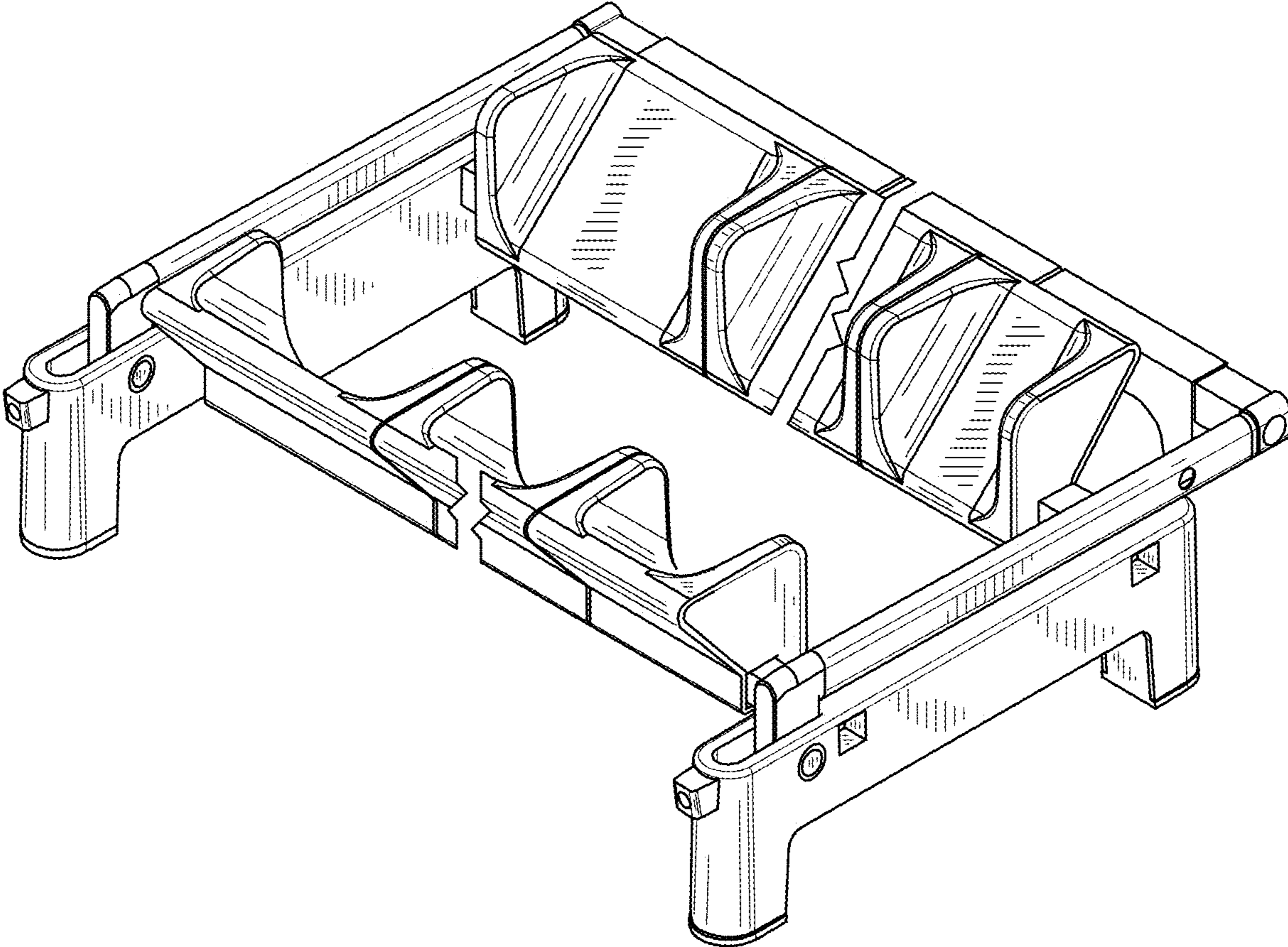

FIG. 8

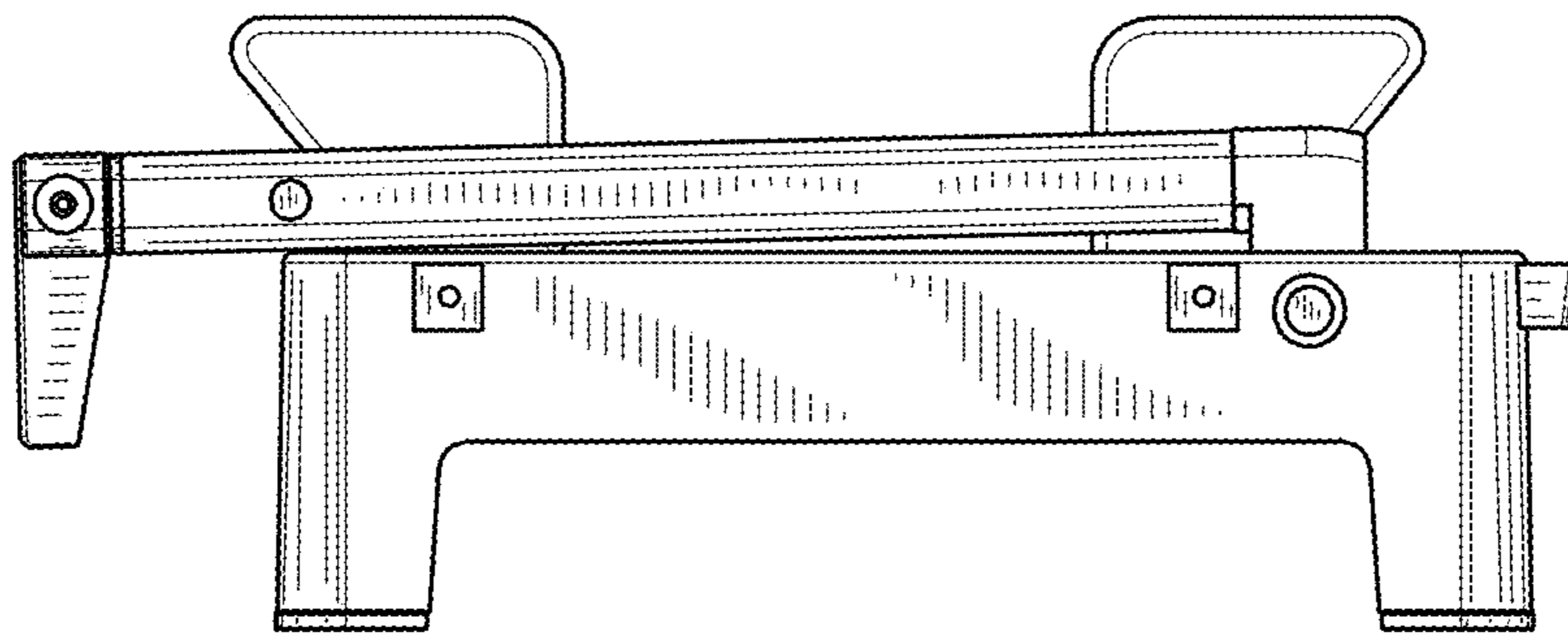

FIG. 9

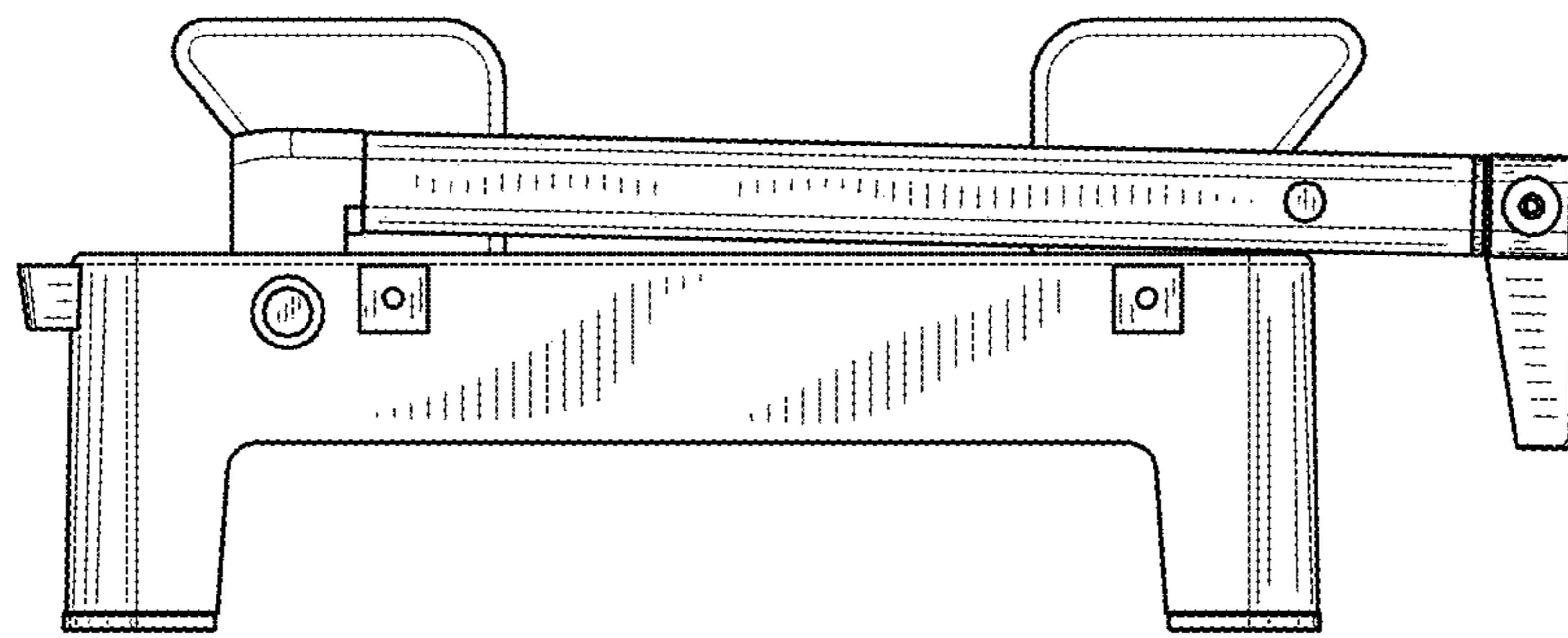

FIG. 10

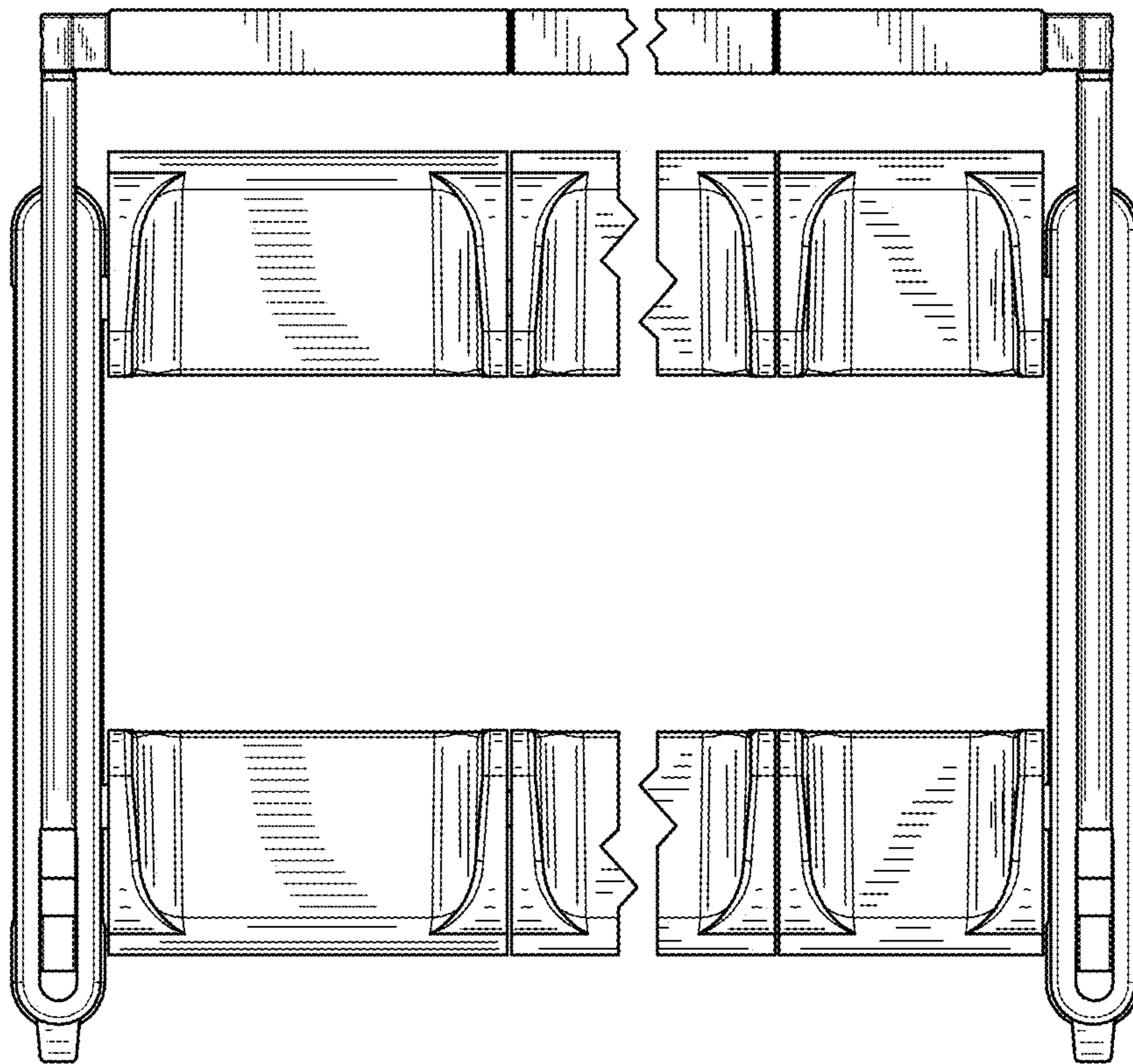

FIG. 11

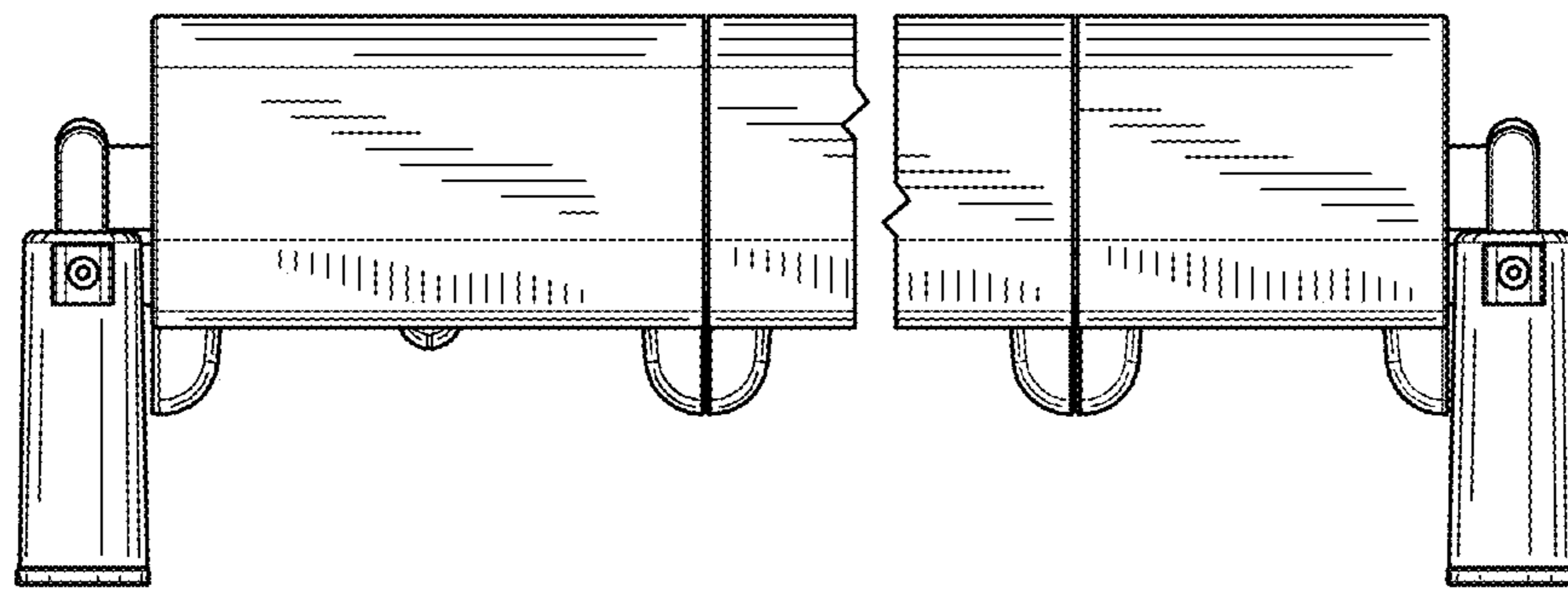

FIG. 12

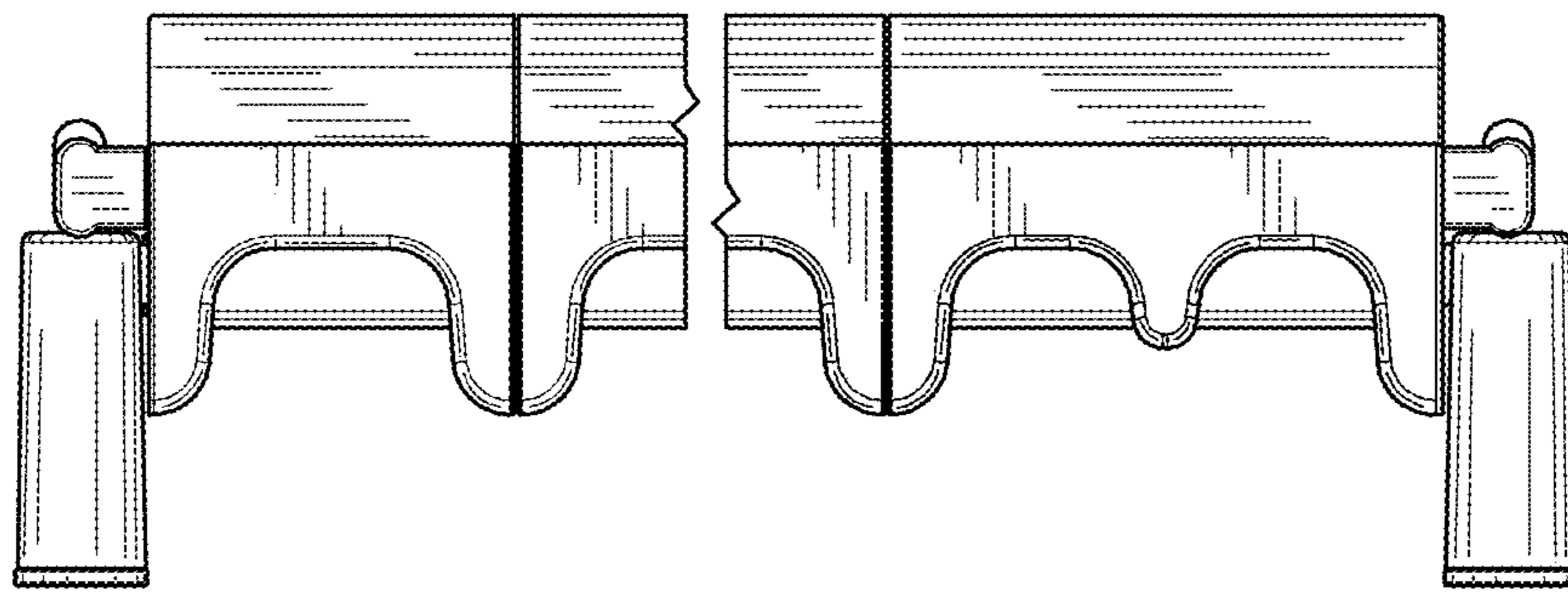

FIG. 13

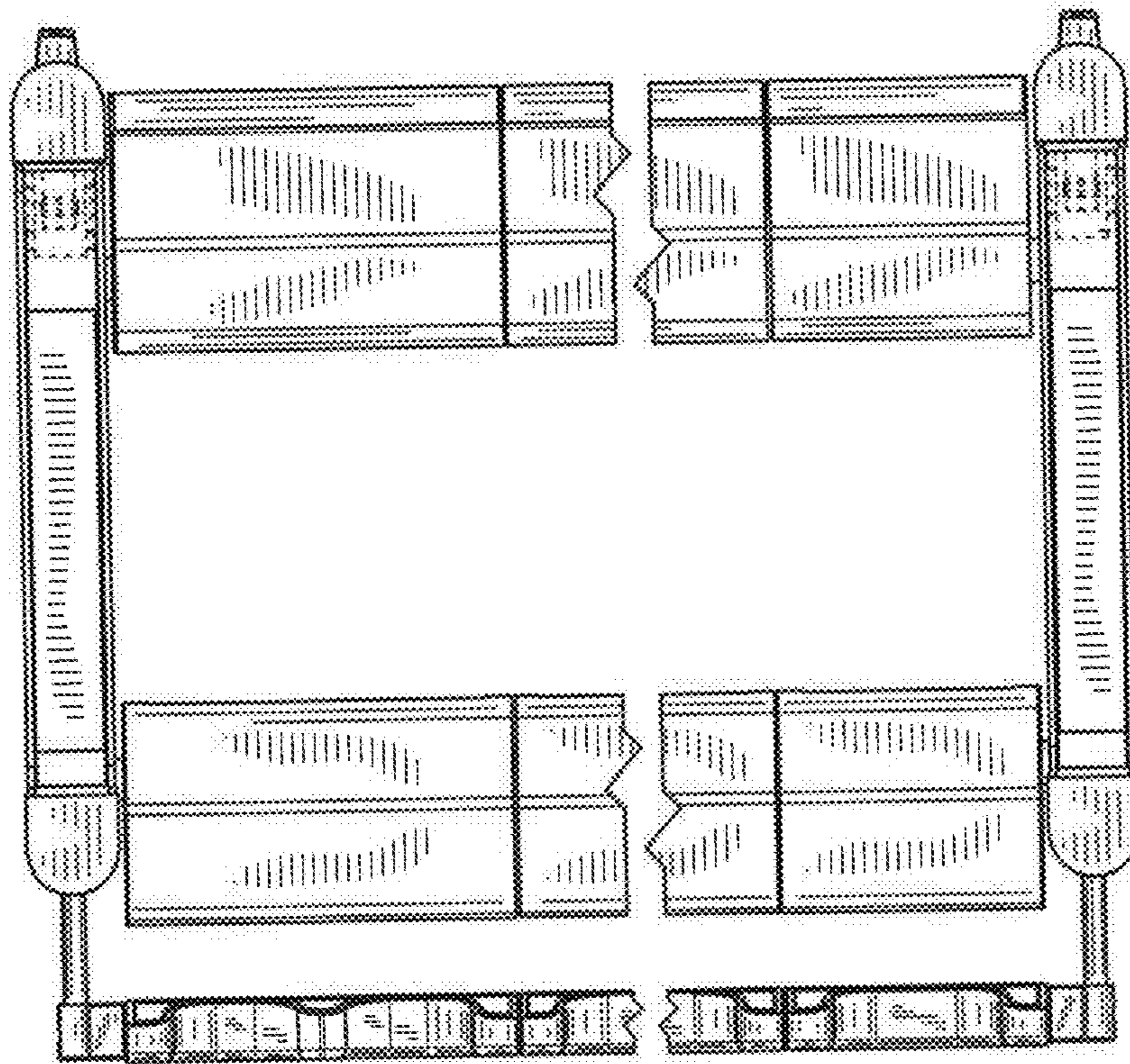

FIG. 14