



US00D874529S

(12) **United States Design Patent**
Steimle et al.

(10) **Patent No.:** **US D874,529 S**

(45) **Date of Patent:** **** Feb. 4, 2020**

(54) **DUNNAGE CONVERSION MACHINE**

(71) Applicant: **Ranpak Corp.**, Concord Township, OH (US)

(72) Inventors: **Michael A. Steimle**, Bainbridge, OH (US); **Douglas C. Corbin**, Twinsburg, OH (US)

(73) Assignee: **Ranpak Corp.**, Cleveland, OH (US)

(**) Term: **15 Years**

(21) Appl. No.: **29/617,266**

(22) Filed: **Sep. 13, 2017**

(51) **LOC (12) Cl.** **15-09**

(52) **U.S. Cl.**
USPC **D15/145**; D9/734

(58) **Field of Classification Search**
USPC D9/414, 417, 434, 440, 447, 456, 499,
D9/702, 713, 730, 734; D15/122, 123,
D15/138, 145, 199

CPC B31D 5/0047; B31D 2205/0035; B31D
2205/0064; B31D 2205/007; B31D
2205/0082; B65D 81/05

See application file for complete search history.

(56) **References Cited**

U.S. PATENT DOCUMENTS

- D370,920 S * 6/1996 Armington D15/127
- D380,212 S * 6/1997 Colby D14/443
- 5,803,893 A * 9/1998 Armington B31D 5/0047
248/676
- 5,908,375 A * 6/1999 Simmons B31D 5/0047
493/346
- 6,076,764 A * 6/2000 Robinson B31H 16/005
242/422.4
- 6,077,209 A * 6/2000 Armington B26D 1/08
493/464

- 6,080,097 A * 6/2000 Ratzel B23Q 5/348
493/346
- 6,416,451 B1 * 7/2002 Ratzel B31D 5/0047
232/43.1
- 6,421,985 B1 * 7/2002 Simmons, Jr. B31D 5/0047
53/472

(Continued)

FOREIGN PATENT DOCUMENTS

- WO 2007143750 * 12/2007 B31D 5/0043
493/464
- WO WO-2018071384 A1 * 4/2018 B31D 5/0047

Primary Examiner — Brett Miller

Assistant Examiner — Fritzgerald L Butac

(74) *Attorney, Agent, or Firm* — Renner, Otto, Boisselle & Sklar, LLP

(57) **CLAIM**

The ornamental design for a dunnage conversion machine, as shown and described.

DESCRIPTION

FIG. 1 is a perspective view of a front, top, and left side of a dunnage conversion machine provided by the invention; FIG. 2 is a perspective view of a rear, top, and right side of the dunnage conversion machine of FIG. 1; FIG. 3 is a front side view of the dunnage conversion machine of FIG. 1; FIG. 4 is a rear side view of the dunnage conversion machine of FIG. 1; FIG. 5 is a right side view of the dunnage conversion machine of FIG. 1; FIG. 6 is a left side view of the dunnage conversion machine of FIG. 1; FIG. 7 is a top side view of the dunnage conversion machine of FIG. 1; and, FIG. 8 is a bottom side view of the dunnage conversion machine of FIG. 1. The portions of the dunnage conversion machine shown in broken lines form no part of the design.

1 Claim, 8 Drawing Sheets

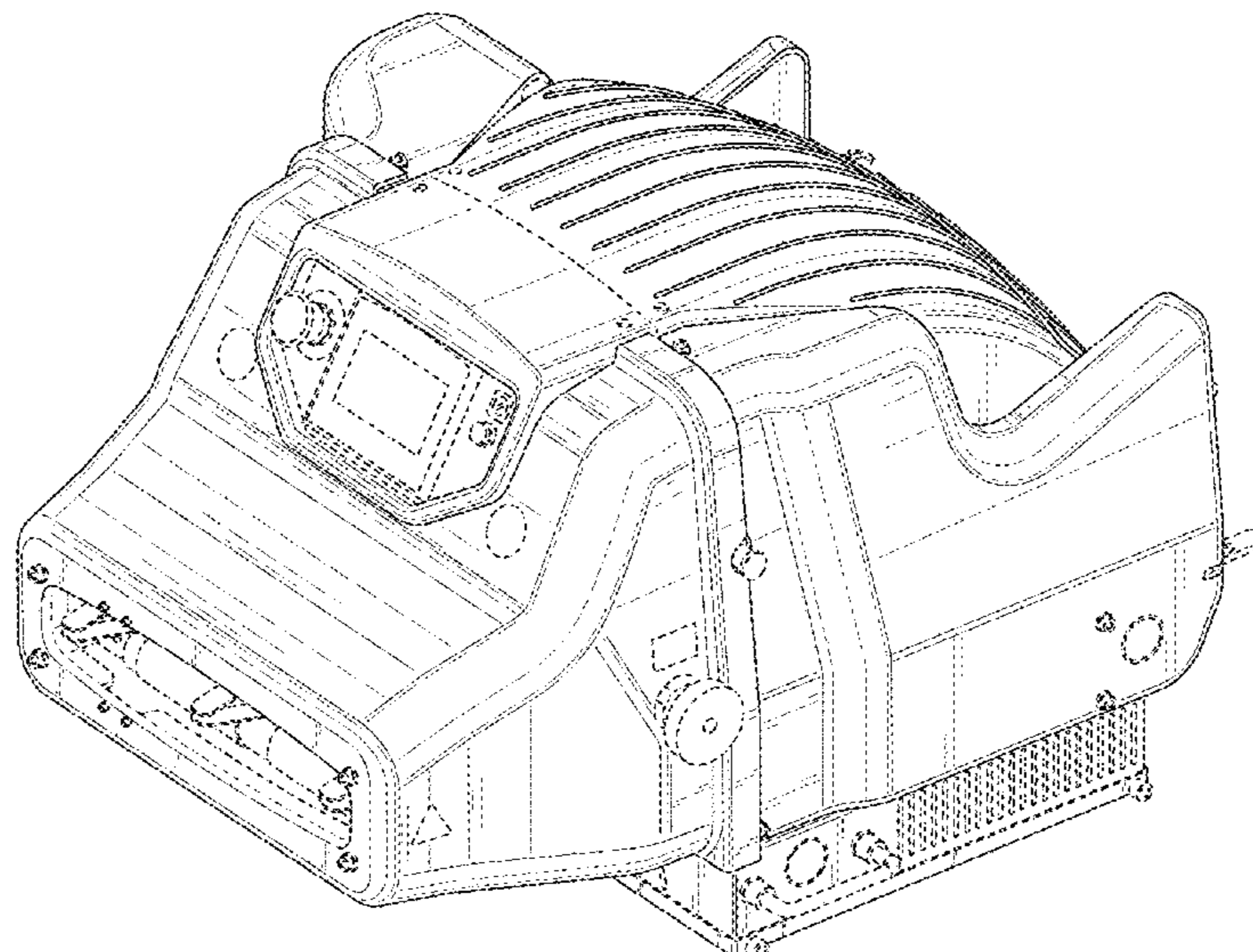

US D874,529 S

Page 2

(56)

References Cited

U.S. PATENT DOCUMENTS

6,524,230 B1 *	2/2003	Harding	B31D 5/0047	493/464
6,676,589 B2 *	1/2004	Kung	B31D 5/0047	493/464
6,877,297 B2 *	4/2005	Armington	B31D 5/0047	53/502
6,918,489 B2 *	7/2005	Harding	B31D 5/0047	206/451
7,044,903 B2 *	5/2006	Simmons, Jr.	B31D 5/0047	493/464
7,794,382 B2 *	9/2010	Cheich	B31D 5/0043	206/409
7,815,989 B2 *	10/2010	Cheich	B31D 5/0047	428/43
D722,626 S *	2/2015	Atzlinger	D15/123	
8,997,440 B2 *	4/2015	Carlson	B31D 5/0047	493/464
D735,488 S *	8/2015	Page	B31D 5/0047	D6/518
D749,871 S *	2/2016	Page	B31D 5/0047	D6/518
9,533,465 B2 *	1/2017	Lintala	B31D 5/0047	
D781,936 S *	3/2017	Broyhill	D15/123	
D784,825 S *	4/2017	Cheich	D25/18	
9,884,465 B2 *	2/2018	Sip	B31D 5/0047	
9,914,279 B2 *	3/2018	Van der Kaap	B31D 5/0039	
10,252,484 B2 *	4/2019	Winkens	B65H 19/29	
2005/0181924 A1 *	8/2005	Demers	B26F 3/02	493/350
2011/0281711 A1 *	11/2011	Chan	B31D 5/0043	493/464
2015/0119224 A1 *	4/2015	Orsini	B31D 5/0043	493/464
2016/0207274 A1 *	7/2016	Schalk	B26D 1/626	
2018/0326692 A1 *	11/2018	Wetsch	B31D 5/0052	

* cited by examiner

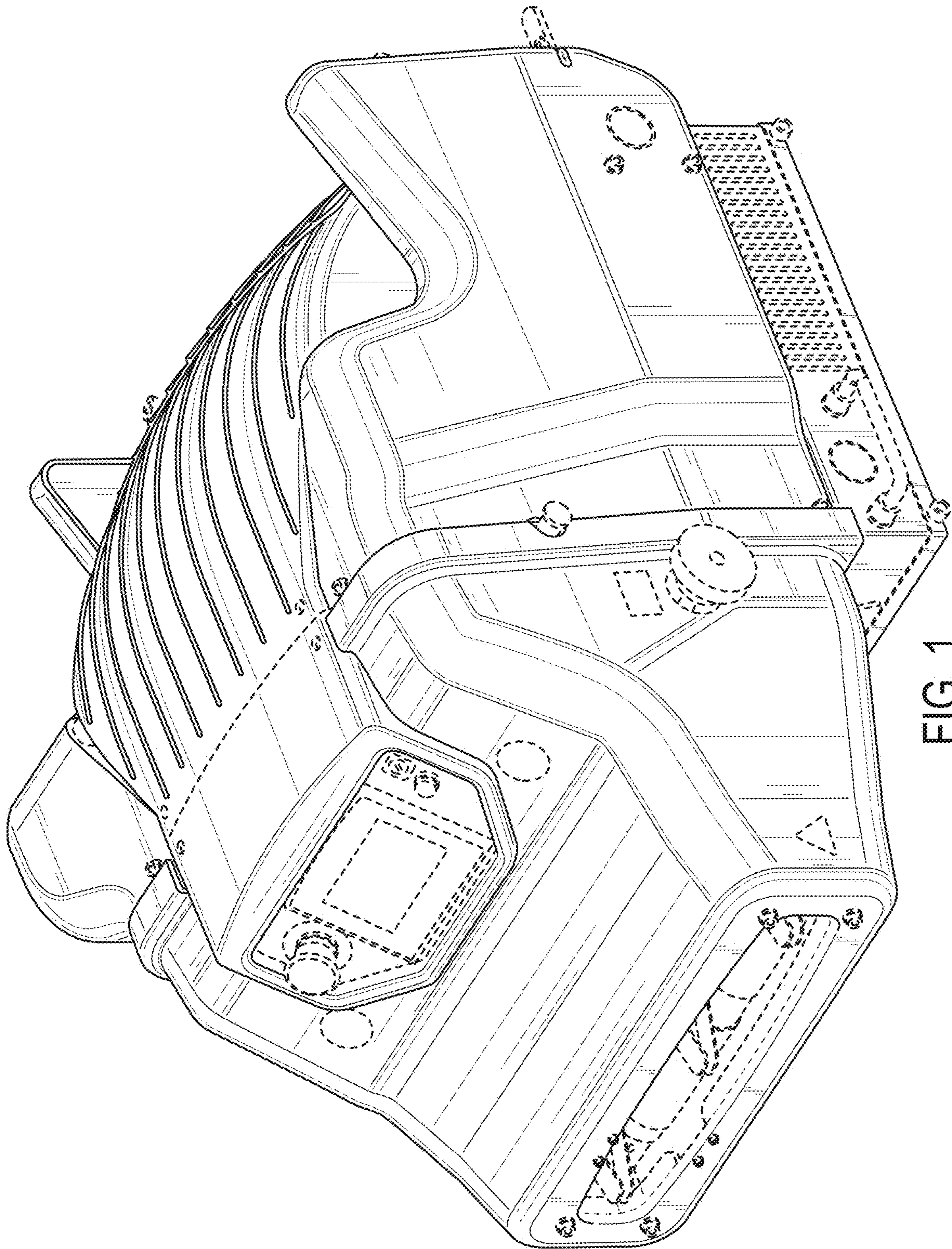

FIG. 1

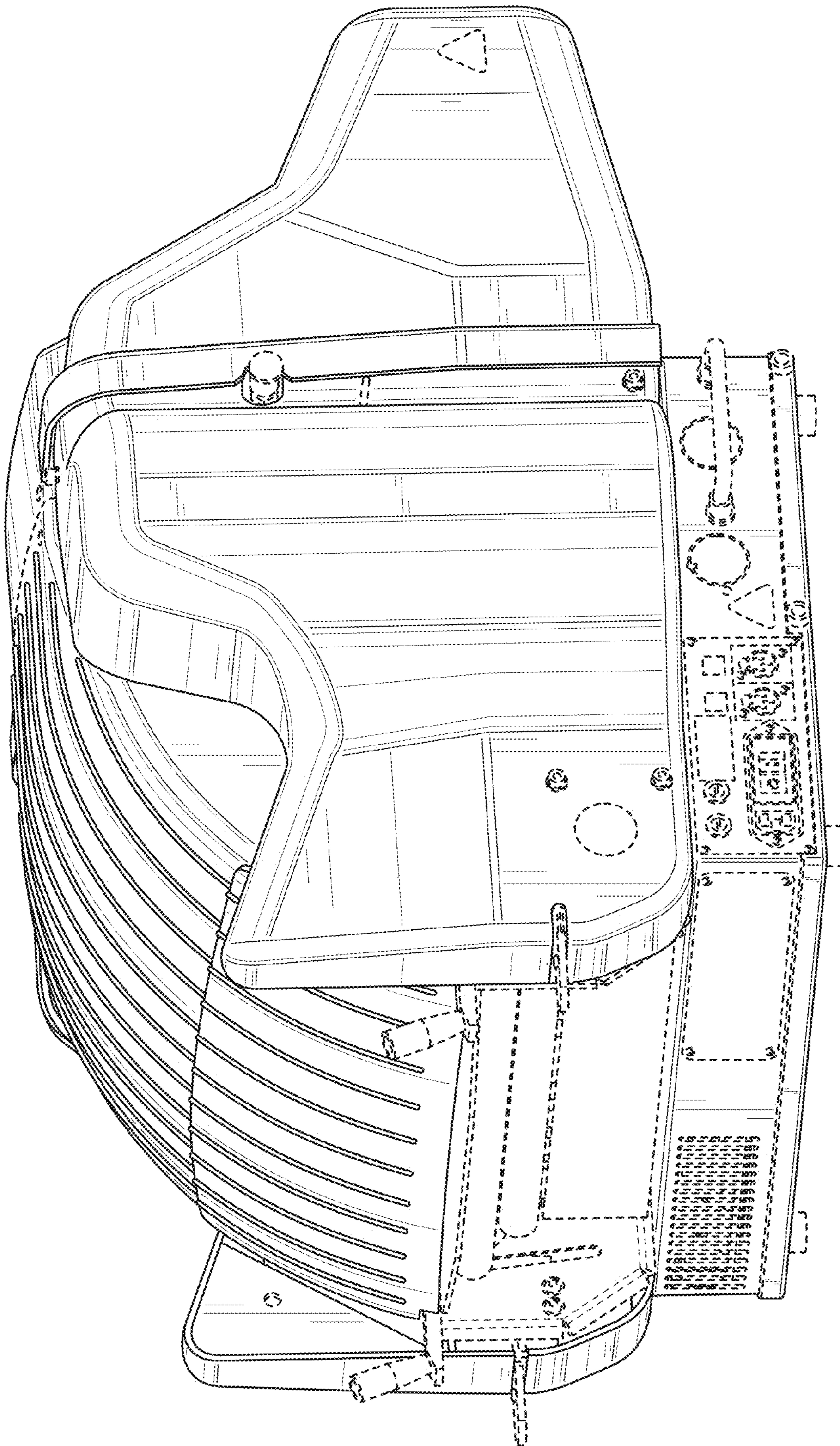

FIG. 2

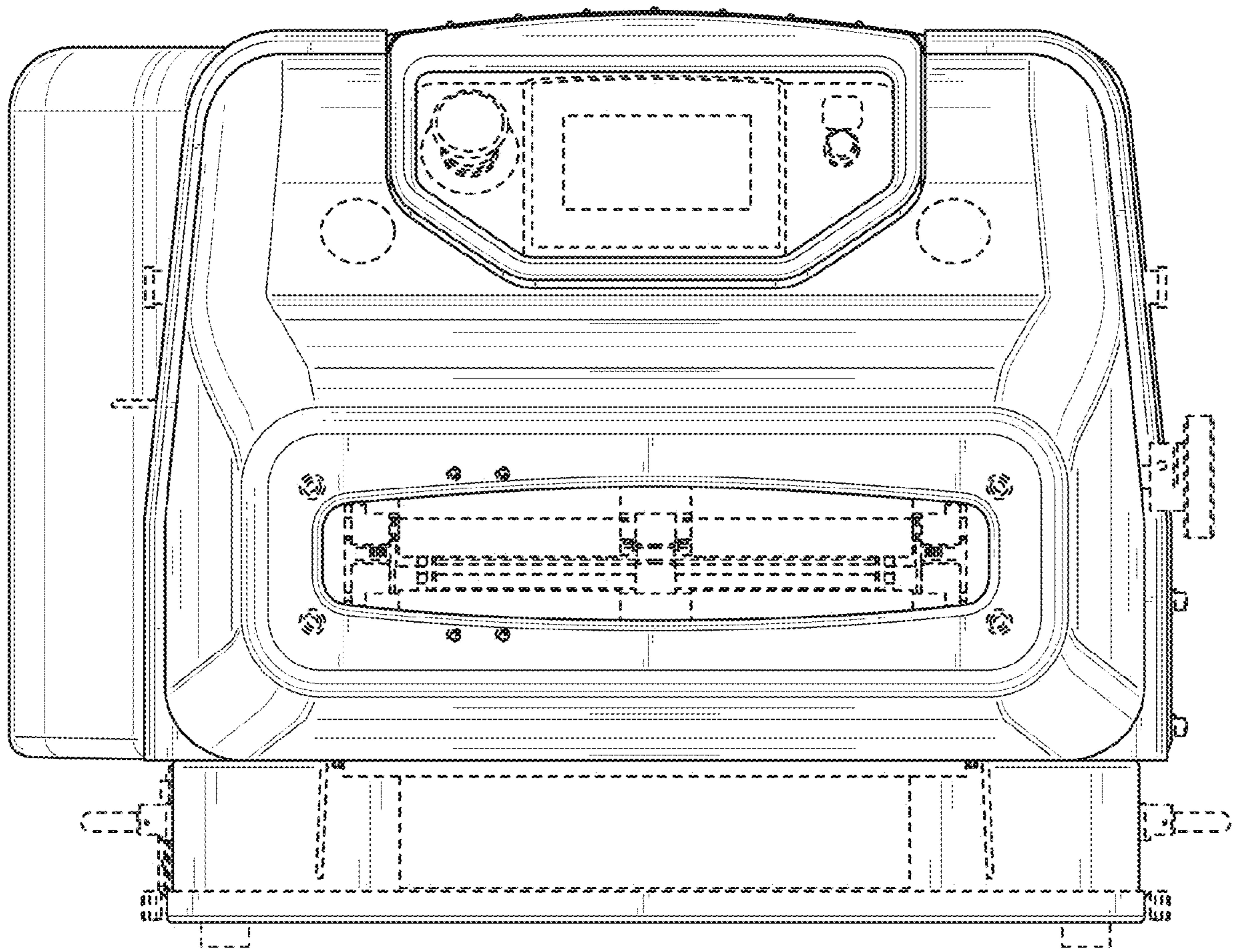

FIG. 3

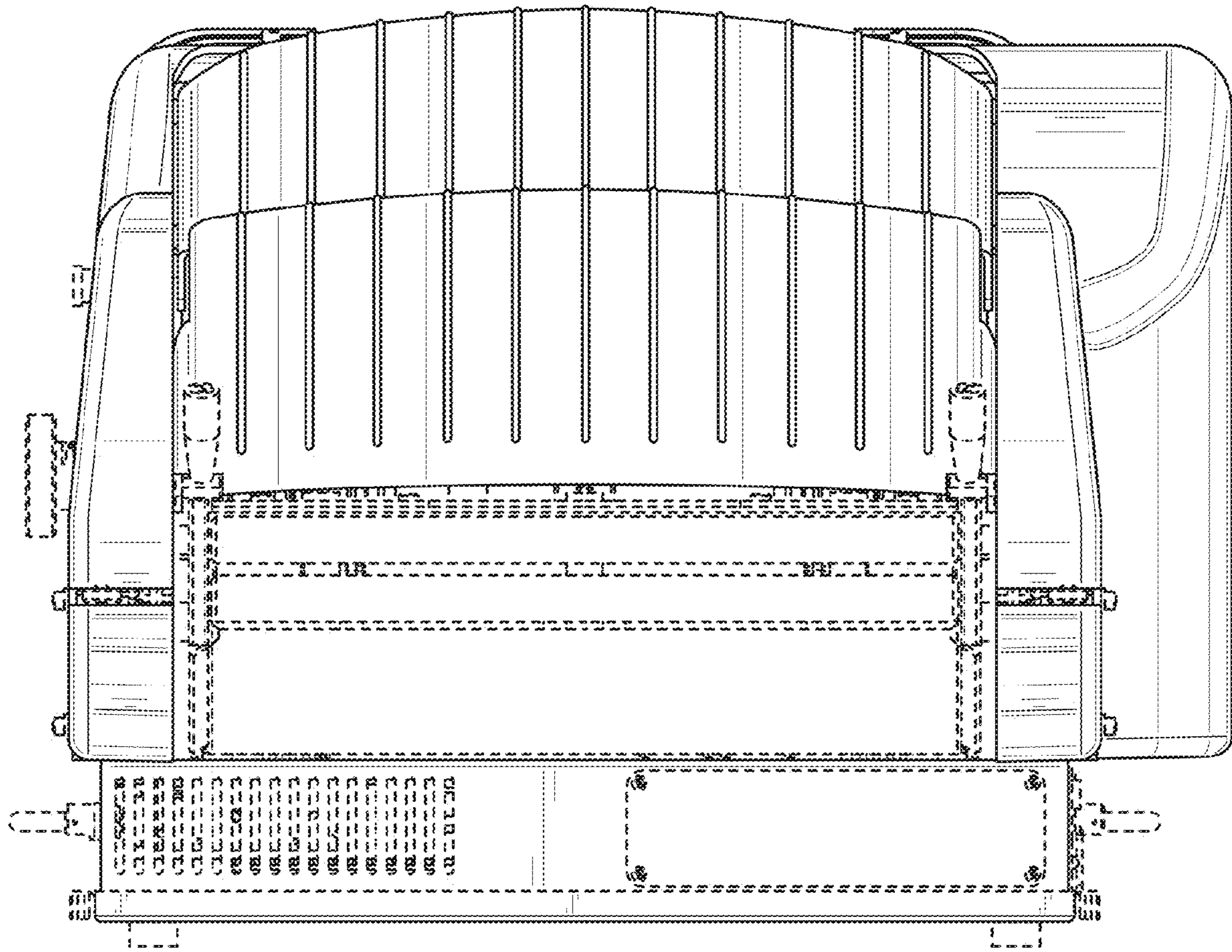

FIG. 4

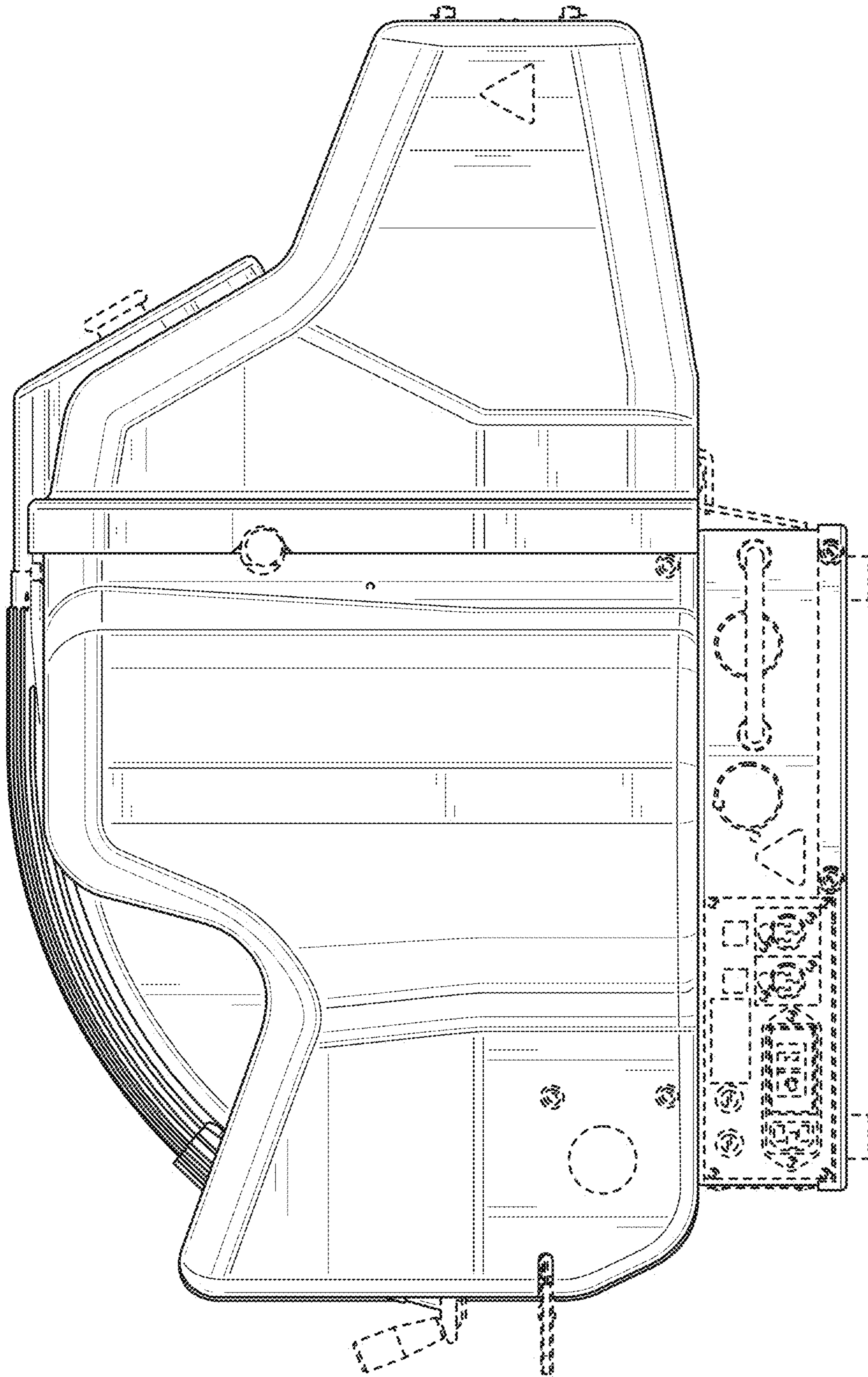

FIG. 5

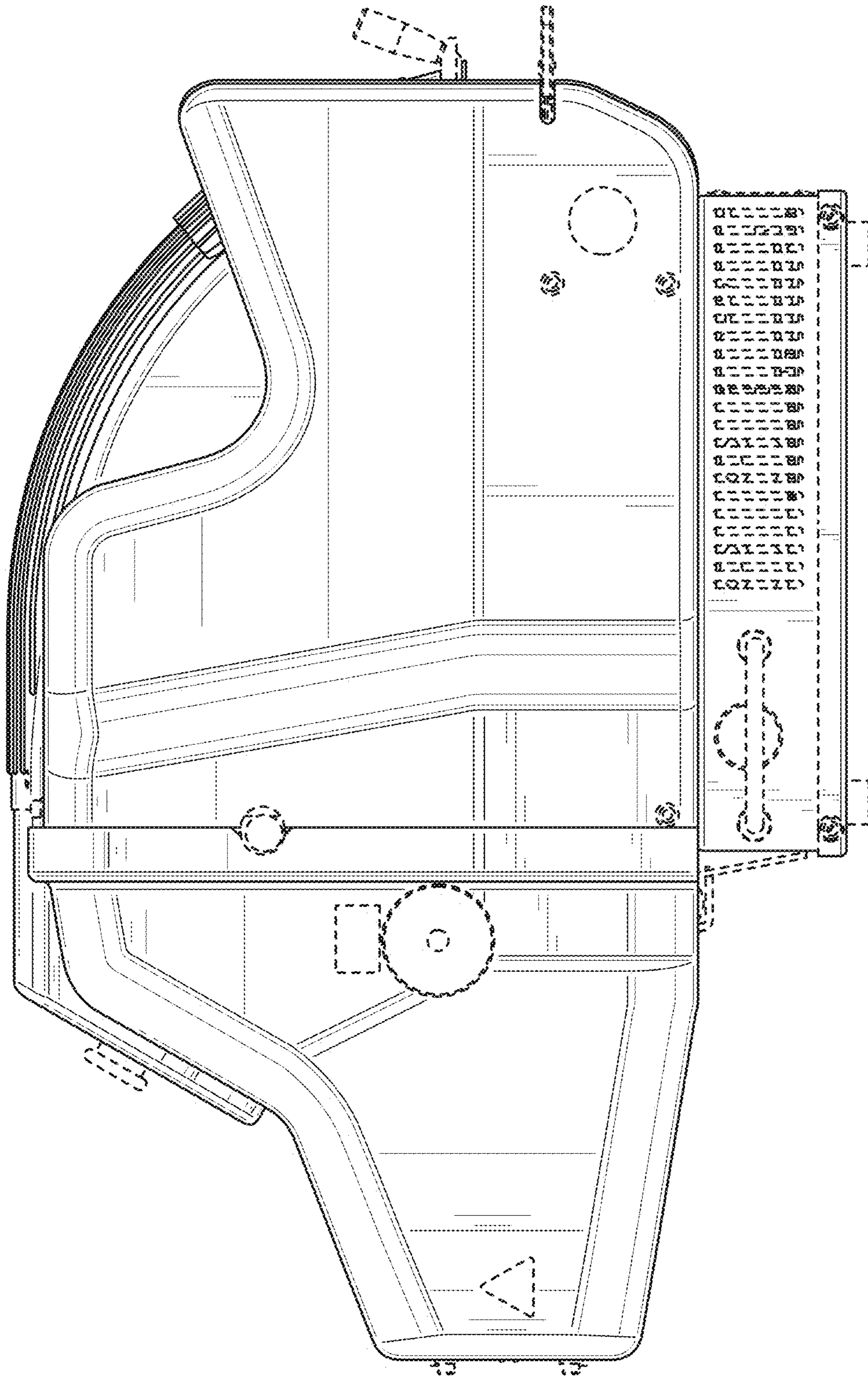

FIG. 6

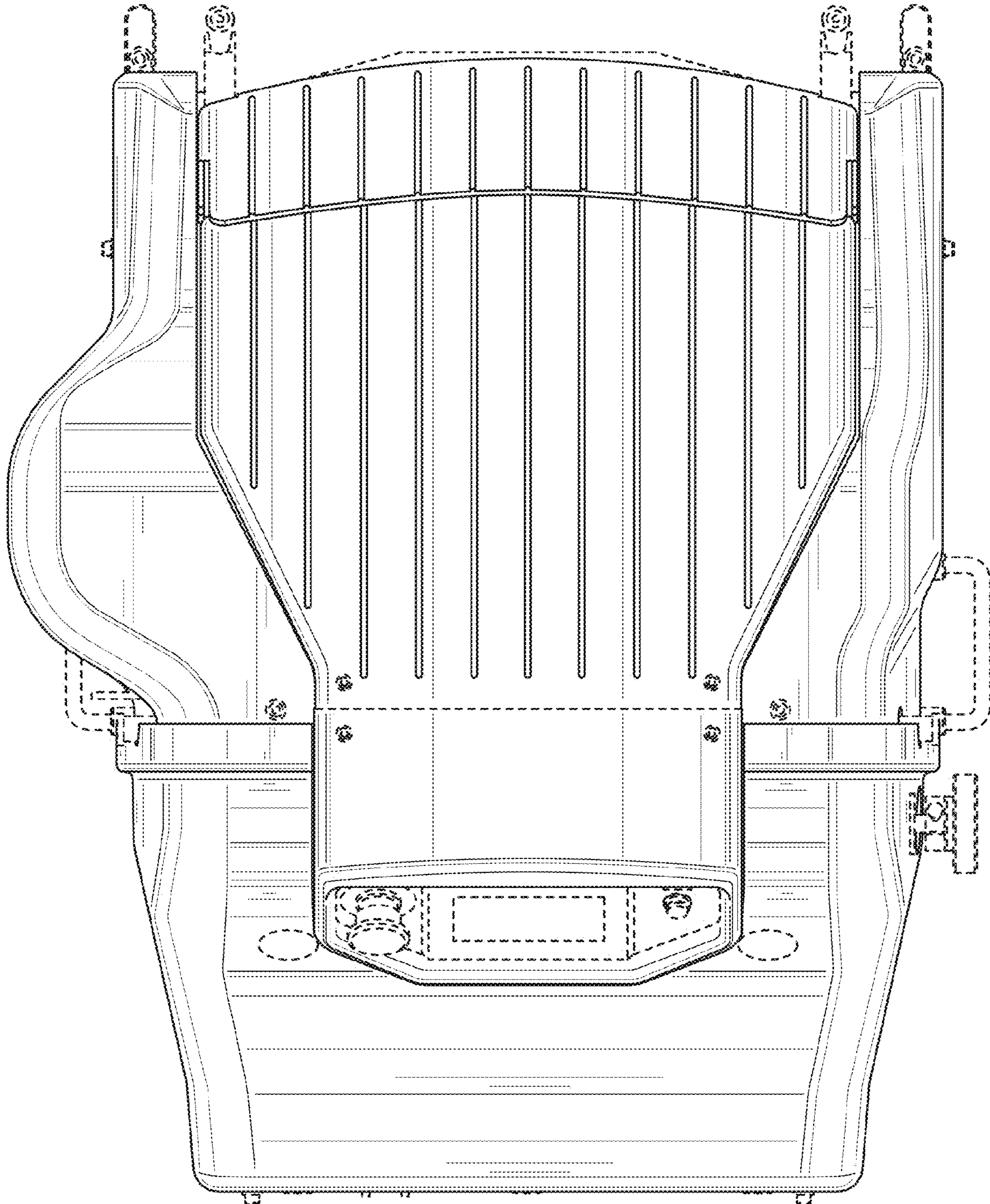

FIG. 7

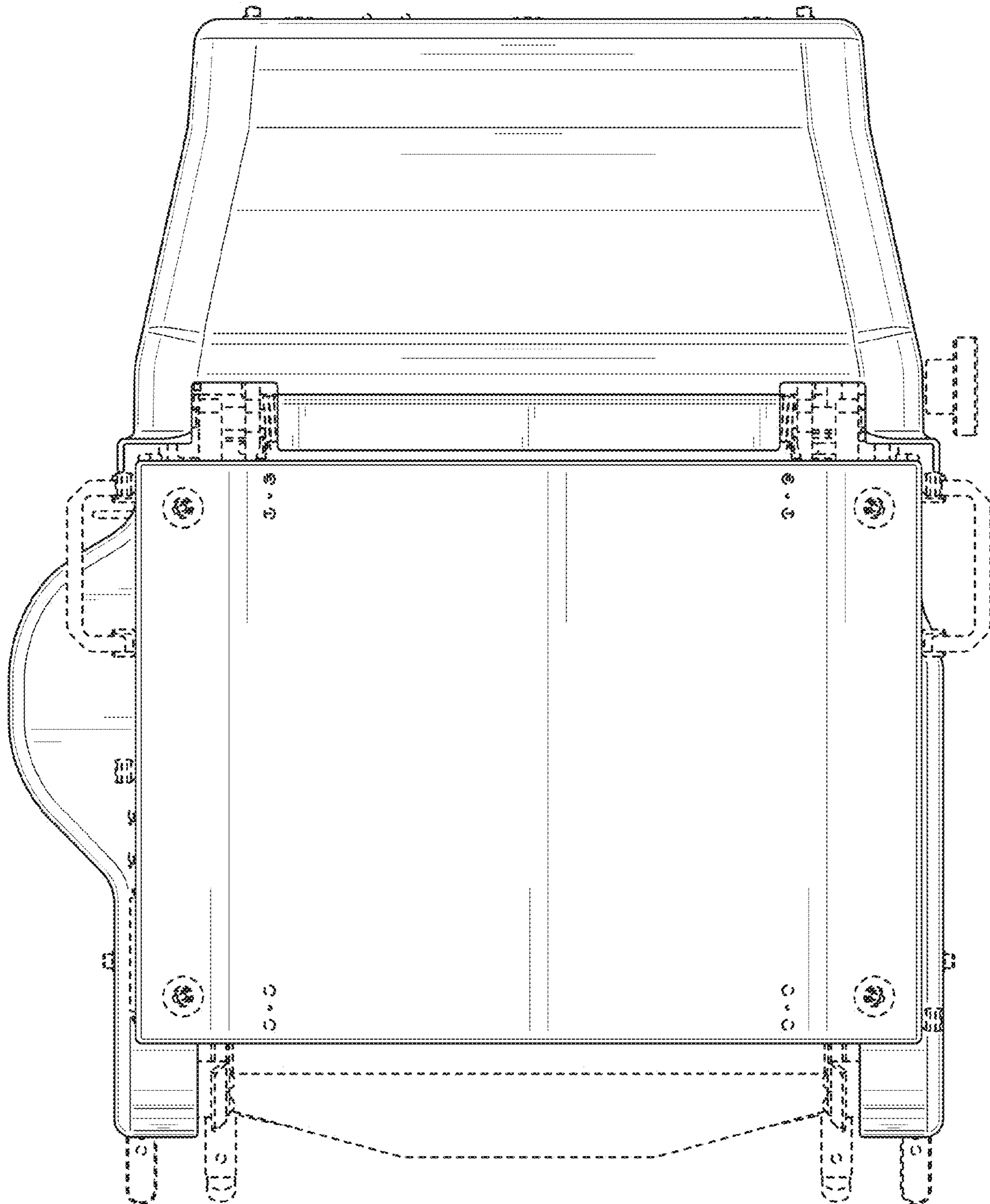

FIG. 8