



US00D874219S

(12) **United States Design Patent** (10) **Patent No.:** **US D874,219 S**
McConnell et al. (45) **Date of Patent:** **** Feb. 4, 2020**

(54) **FOOD PROCESSING ATTACHMENT**

(71) Applicant: **WHIRLPOOL CORPORATION**,
Benton Harbor, MI (US)

(72) Inventors: **John W. McConnell**, St. Joseph, MI
(US); **Wenkai Wu**, Aurora, IL (US)

(73) Assignee: **Whirlpool Corporation**, Benton
Harbor, MI (US)

(**) Term: **15 Years**

(21) Appl. No.: **29/698,967**

(22) Filed: **Jul. 22, 2019**

Related U.S. Application Data

(63) Continuation of application No. 29/663,694, filed on
Sep. 18, 2018, now Pat. No. Des. 861,425, which is
a continuation of application No. 29/589,335, filed on
Dec. 30, 2016, now Pat. No. Des. 831,421.

(51) **LOC (12) Cl.** **31-00**

(52) **U.S. Cl.**
USPC **D7/401.2; D7/381**

(58) **Field of Classification Search**

USPC D7/372, 376–386, 412–413, 602, 629,
D7/665–666, 669, 679, 693–694
CPC A21C 1/02; A21C 1/04; A23N 1/00; A23N
1/02; A23N 4/14; A23N 7/026; A47J
17/16; A47J 43/04; A47J 43/25; A47J
43/27; A47J 43/042; A47J 43/044; A47J
43/046; A47J 43/075; A47J 43/0722;
A47J 43/0727; B01F 3/00; B01F 3/0807;
B01F 3/0853; B01F 13/0059; B01F
13/0064; B02C 1/08; B02C 2/04; B02C
4/42; B02C 4/142; B02C 4/143; B02C
4/423; B02C 13/1835; B26D 1/03; B26D
3/11; B28C 5/10; B28C 5/12; B28C 5/14;
B28C 5/16

See application file for complete search history.

(56) **References Cited**

U.S. PATENT DOCUMENTS

242,660 A *	6/1881	Law	A47J 17/16 99/598
256,214 A	4/1882	Heizmann	
292,554 A *	1/1884	Geer	A47J 17/16 99/595
310,196 A *	1/1885	Goodell	A47J 17/16 99/598
430,139 A	6/1890	Meyer	
633,932 A	9/1899	Williamson	

(Continued)

Primary Examiner — Ricky Pham

(74) *Attorney, Agent, or Firm* — Price Heneveld LLP

(57) **CLAIM**

We claim the ornamental design for a food processing
attachment, as shown and described.

DESCRIPTION

FIG. 1 is a top perspective view of the food processing
attachment of the present invention;
FIG. 2 is bottom perspective view of the food processing
attachment of the present invention;
FIG. 3 is a first side elevation view of the food processing
attachment of the present invention;
FIG. 4 is a second side elevation view of the food processing
attachment of the present invention;
FIG. 5 is a third side elevation view of the food processing
attachment of the present invention;
FIG. 6 is a fourth side elevation view of the food processing
attachment of the present invention;
FIG. 7 is a top plan view of the food processing attachment
of the present invention; and,
FIG. 8 is a bottom plan view of the food processing
attachment of the present invention.
The broken lines in the figures are for contextual purposes
or show the environment and form no part of the claimed
design.

1 Claim, 7 Drawing Sheets

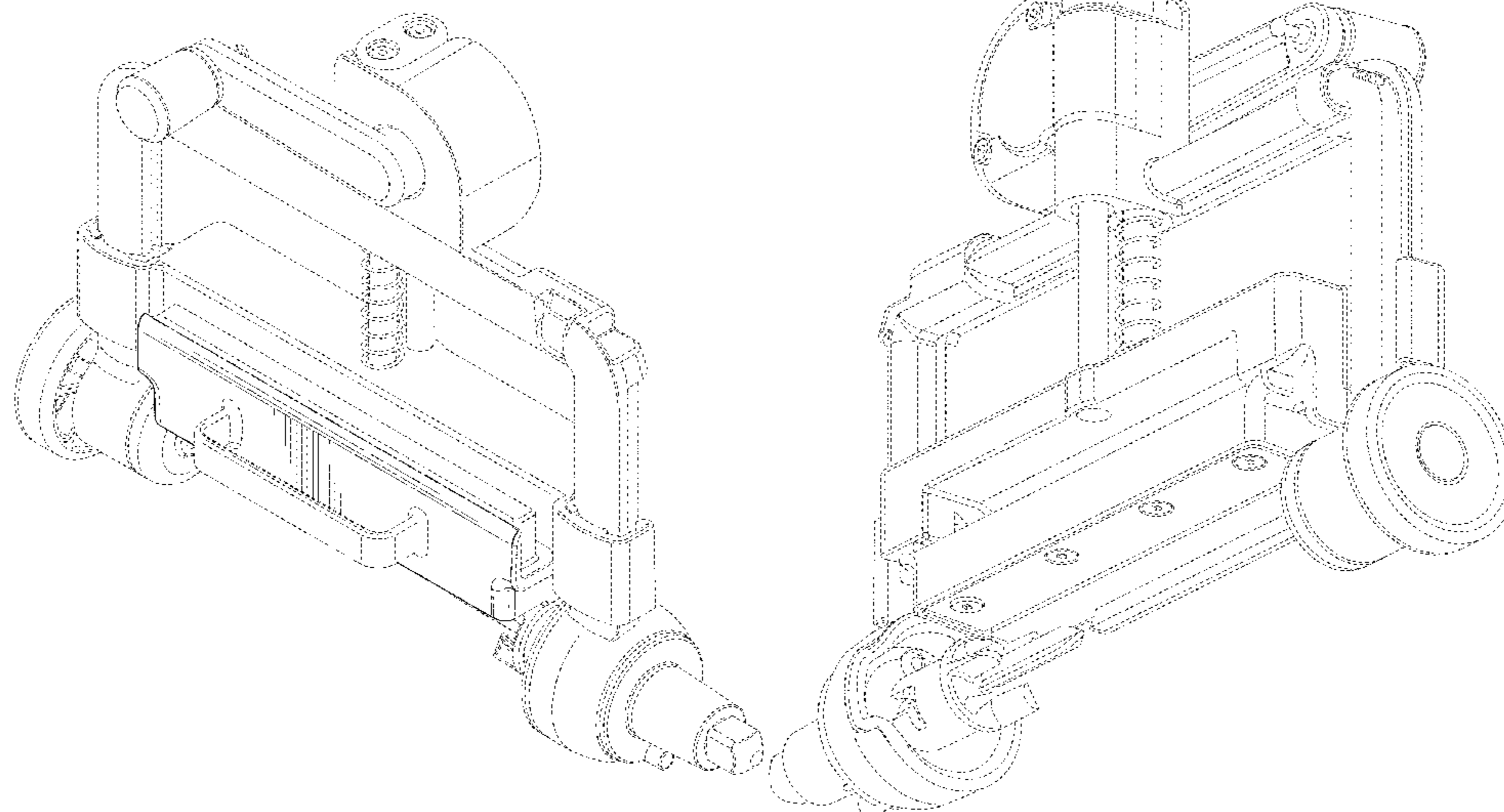

US D874,219 S

Page 2

(56)

References Cited

U.S. PATENT DOCUMENTS

954,340 A *	4/1910	Phillips	A23N 4/14	5,557,998 A	9/1996	Schwartz et al.	
				99/543	5,690,022 A	11/1997	Chai	
959,137 A	5/1910	Hinchliffe			5,950,528 A	9/1999	Wang	
1,008,555 A	11/1911	Mower			D414,983 S	10/1999	Wong	
1,511,137 A *	10/1924	Pichler	A47J 17/16	6,053,098 A	4/2000	Yamamoto	
				99/596	6,314,849 B1	11/2001	Arrasmith	
1,956,492 A	4/1934	China			6,516,713 B1 *	2/2003	Holmander A23N 7/026
1,966,186 A	7/1934	Remnsnider						99/541
2,056,843 A	10/1936	Erro			6,523,464 B1	2/2003	Widelo	
2,307,829 A	1/1943	Ellis			6,854,383 B2	2/2005	Wang	
2,361,241 A	10/1944	Rogers			7,032,491 B2	4/2006	Fischer	
2,375,489 A *	5/1945	Oskow	A47J 17/16	D669,324 S	10/2012	Bodum	
				99/595	8,596,176 B1	12/2013	Wagner	
2,410,683 A	11/1946	Marquez			D773,894 S	12/2016	Benoit et al.	
2,464,993 A	3/1949	Ross			D793,181 S	8/2017	Wong	
2,489,581 A *	11/1949	Mason	B26D 3/11	9,731,428 B2	8/2017	Levine et al.	
				82/173	D797,495 S	9/2017	McConnell et al.	
2,508,868 A	5/1950	Ross			10,021,904 B1	7/2018	Fikes	
2,566,568 A	9/1951	Ives			D831,421 S	10/2018	McConnell et al.	
2,693,210 A	11/1954	Gustafson			10,183,409 B2 *	1/2019	Bagley B26D 1/03
3,881,406 A	5/1975	Perez			D842,024 S	3/2019	Li	
3,952,621 A	4/1976	Chambos			2004/0261634 A1 *	12/2004	Wang A47J 17/16
4,038,915 A	8/1977	Saito						99/584
4,579,028 A	4/1986	Neidhardt			2008/0314262 A1 *	12/2008	Stark A47J 17/16
								99/595
					2012/0090480 A1 *	4/2012	Caspar B26D 3/11
								99/537

* cited by examiner

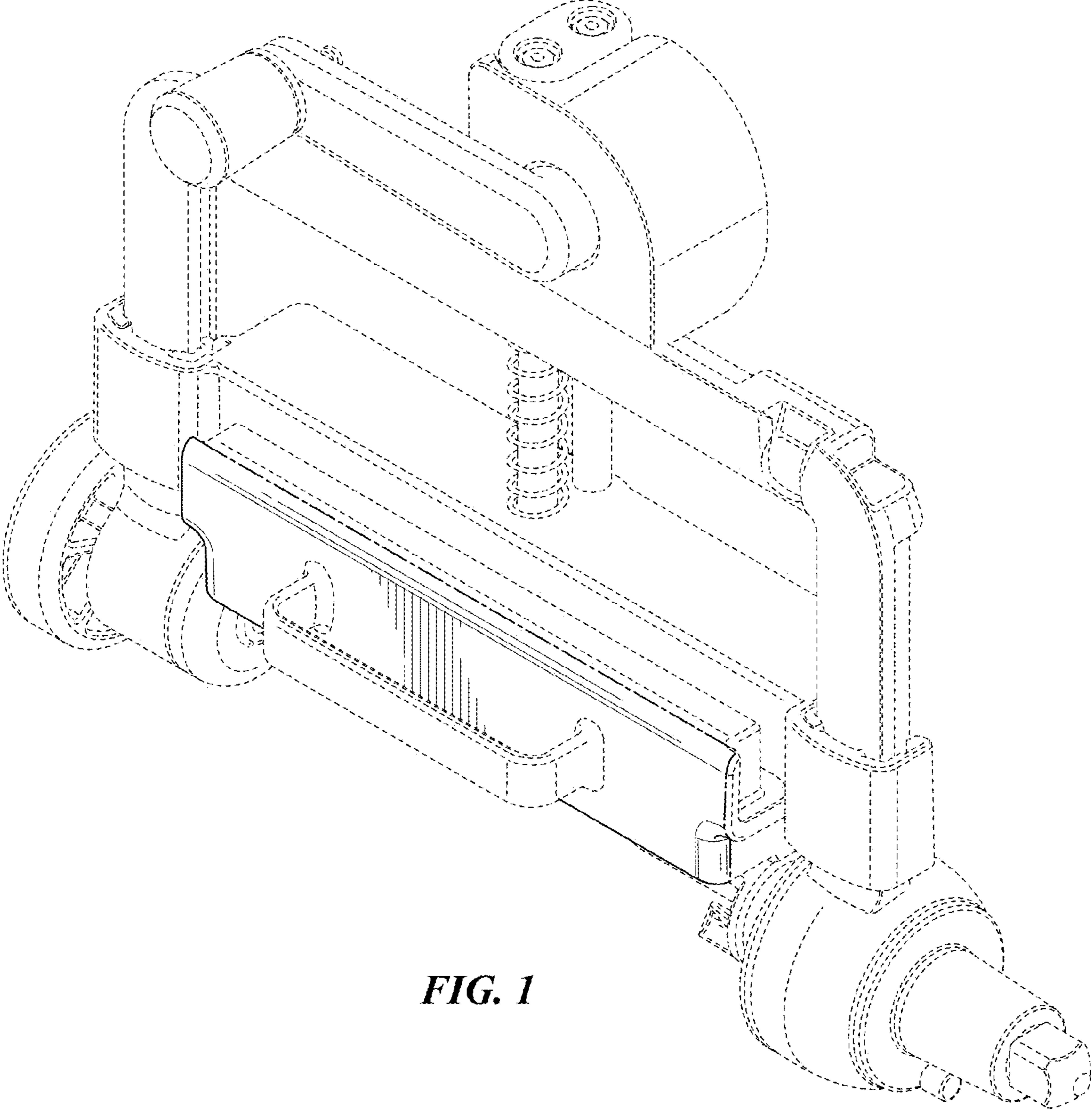

FIG. 1

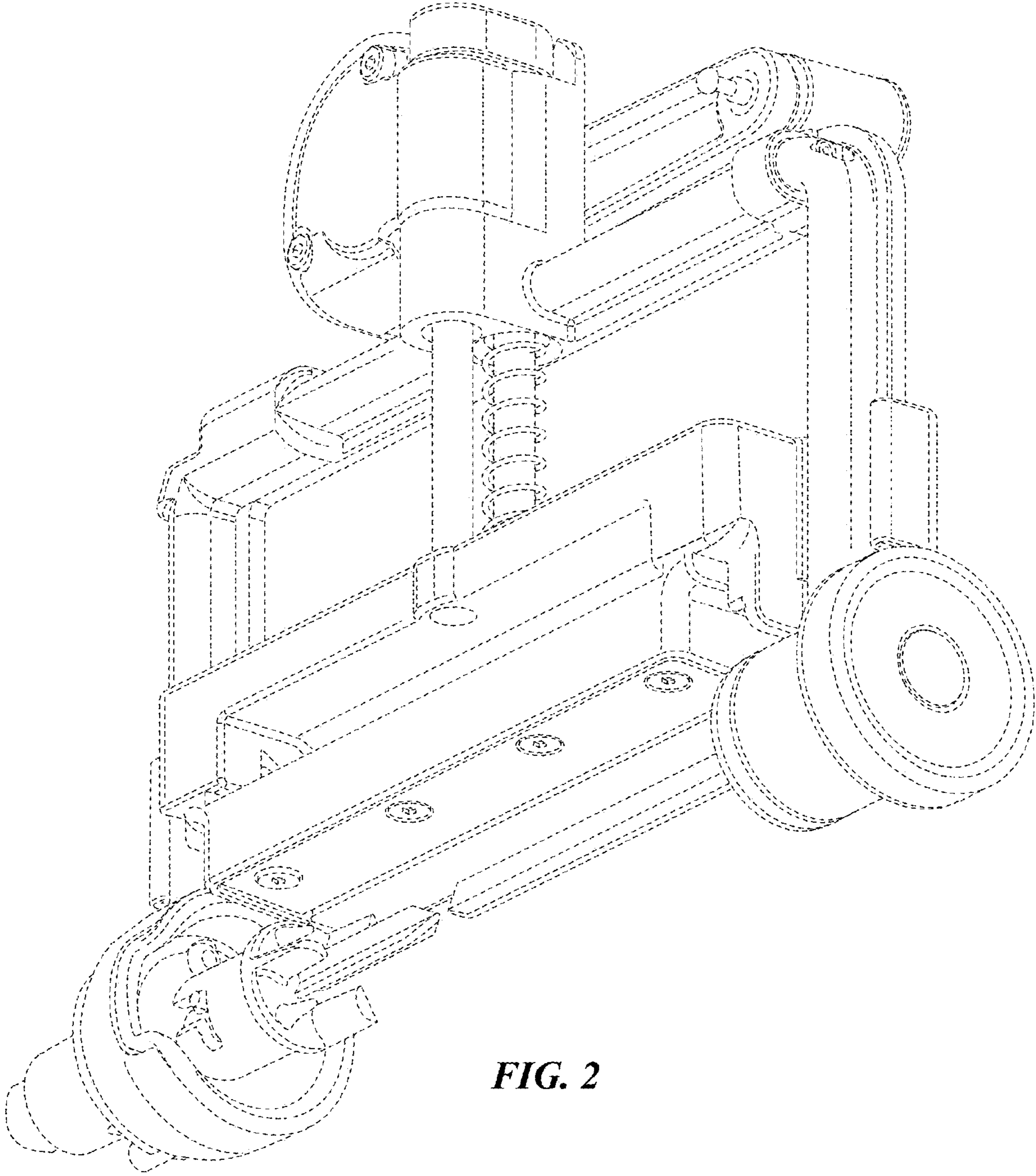

FIG. 2

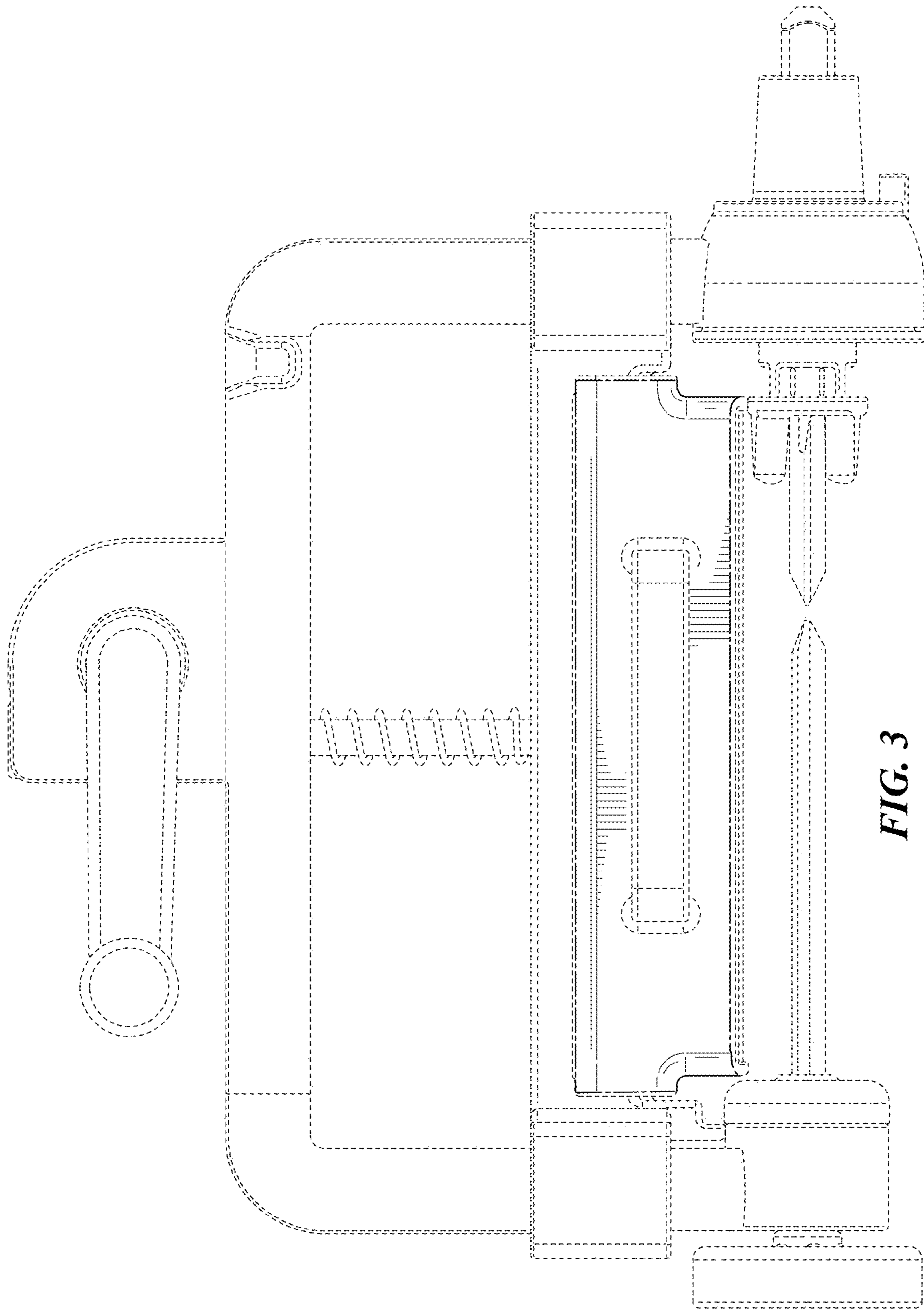

FIG. 3

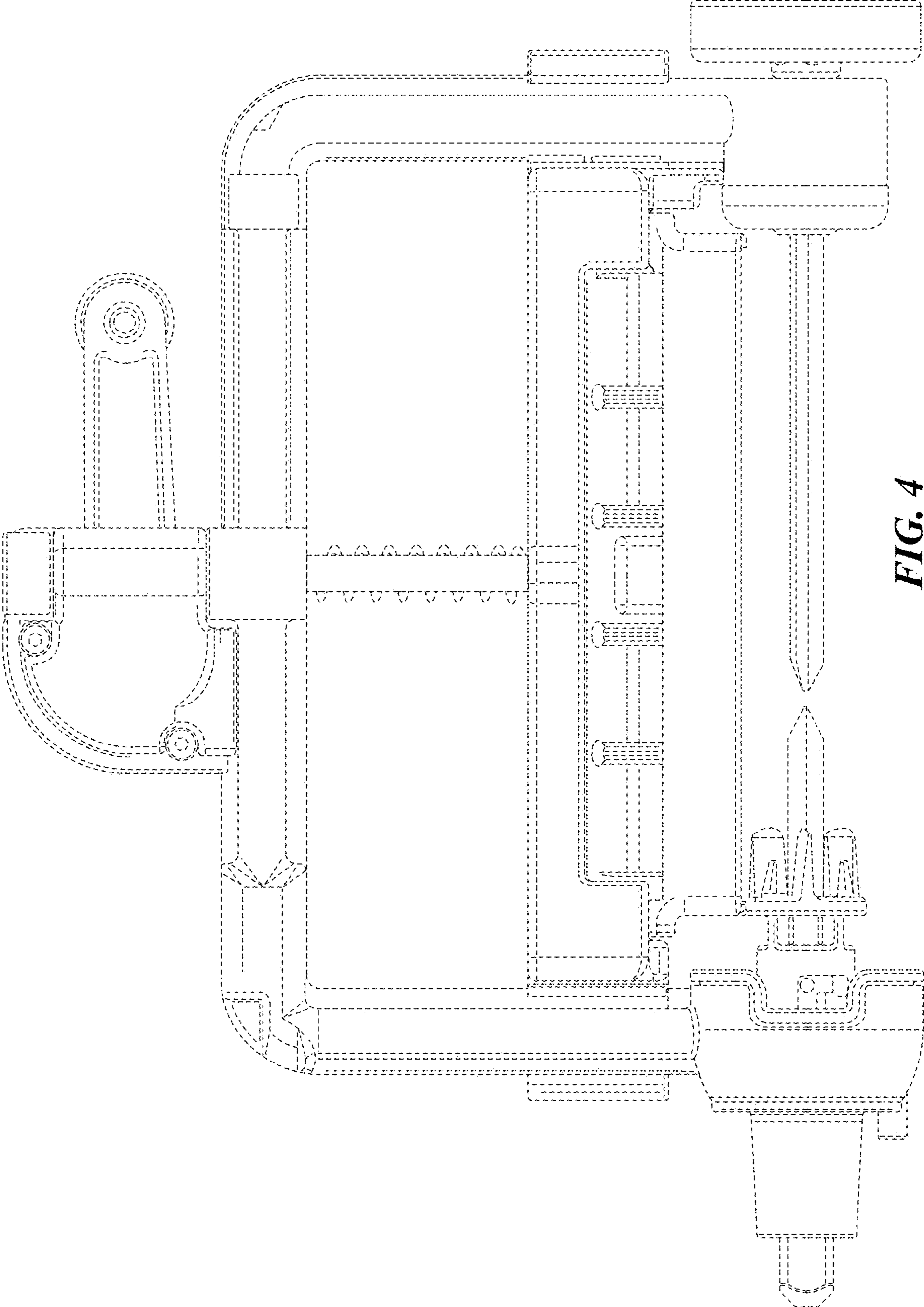

FIG. 4

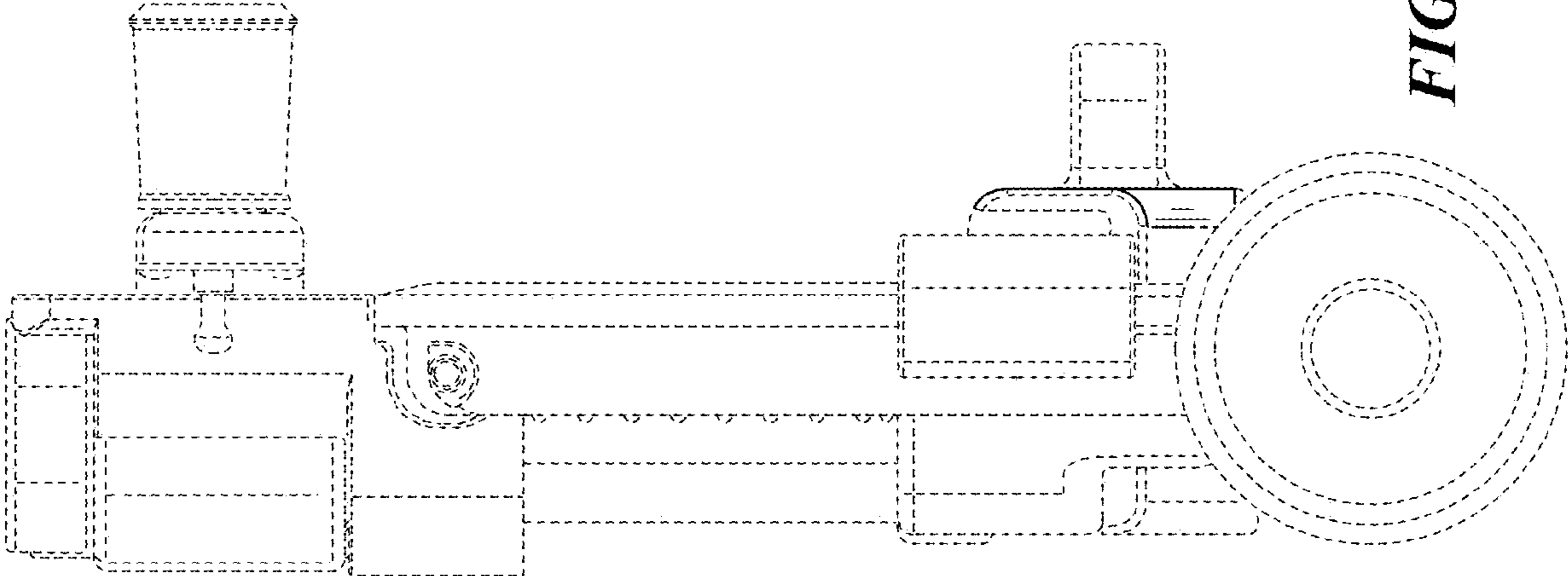

FIG. 6

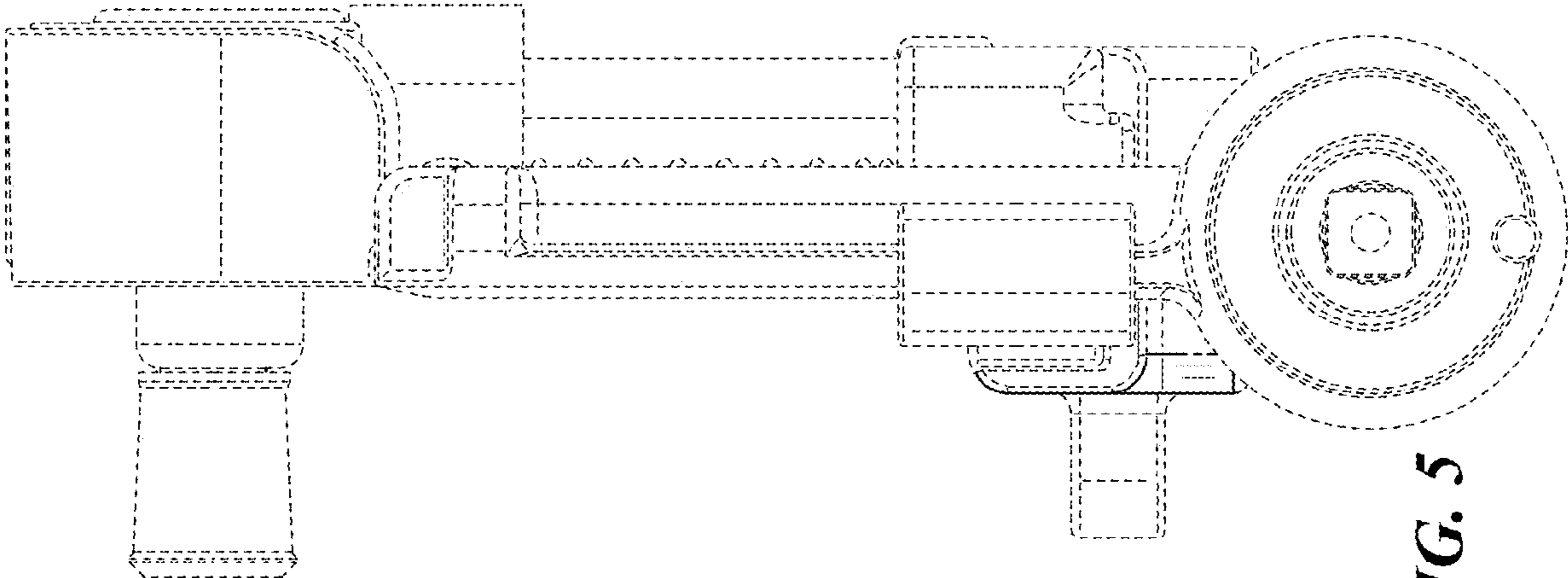

FIG. 5

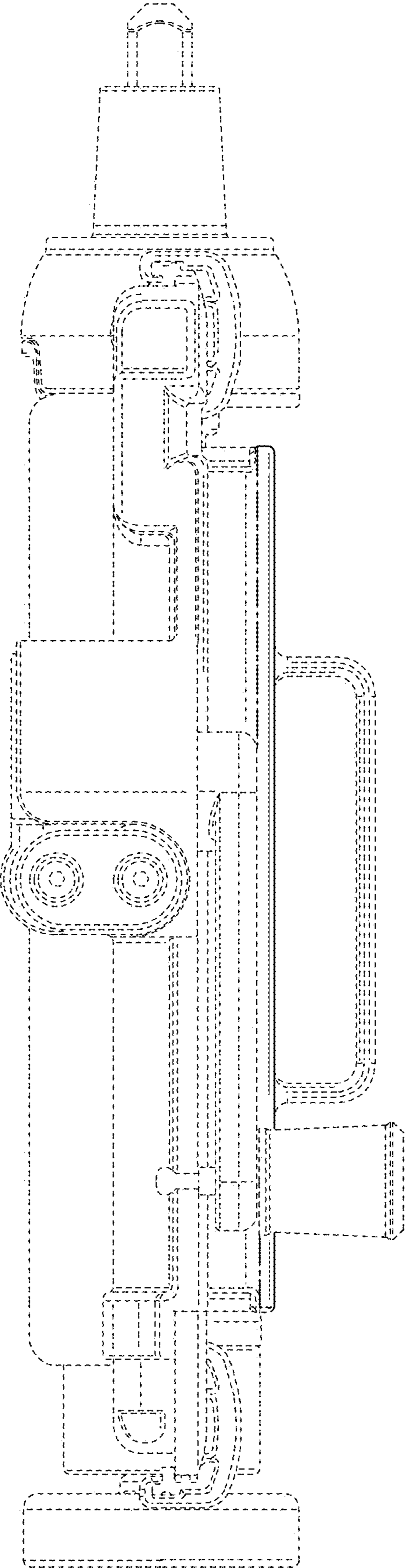

FIG. 7

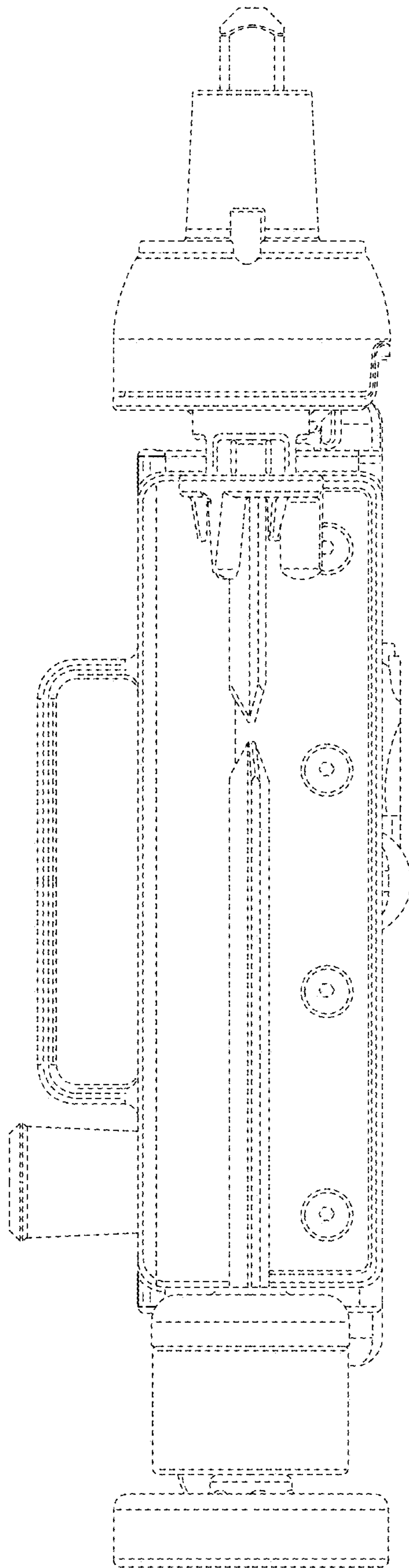

FIG. 8