



US00D874214S

(12) **United States Design Patent** (10) **Patent No.:** **US D874,214 S**
Breit et al. (45) **Date of Patent:** **** Feb. 4, 2020**

- (54) **BOTTLE CAP**
- (71) Applicant: **O2COOL, LLC**, Chicago, IL (US)
- (72) Inventors: **Oliver Breit**, Midvale Village (HK); **Lars Junker**, Kowloon (HK); **Vicky Hui**, Tsing Yi (HK); **Michael Ksiazek**, Burr Ridge, IL (US)
- (73) Assignee: **O2COOL, LLC**, Chicago, IL (US)
- (**) Term: **15 Years**
- (21) Appl. No.: **29/609,979**
- (22) Filed: **Jul. 7, 2017**
- (51) **LOC (12) Cl.** **07-99**
- (52) **U.S. Cl.**
USPC **D7/392; D7/392.1**
- (58) **Field of Classification Search**
USPC D9/452, 453, 454, 435, 447, 449;
D7/391, 392, 392.1, 510, 511, 538, 540,
D7/542, 543, 544, 545, 629
CPC ... A47G 19/2205; A47G 19/2222; A45F 3/16;
A45F 3/20; B67D 7/06; B67D 7/0004;
B65D 25/14; B65D 47/065; B65D
47/066; B65D 2543/00101; B65D
2543/00027
See application file for complete search history.

D702,505 S *	4/2014	Nakatani	D7/605
D718,626 S *	12/2014	Lane	B65D 41/62
				D9/449
D744,290 S *	12/2015	Endo	D7/608
D773,255 S *	12/2016	Horimoto	D7/608
D794,453 S *	8/2017	Boroski	D7/392.1
D795,011 S *	8/2017	Pisarevsky	D7/507
D829,054 S *	9/2018	Breit	D7/510
D830,118 S *	10/2018	Ksiazek	D7/392.1
2011/0284541 A1 *	11/2011	Webster	B65D 23/10
				220/288

FOREIGN PATENT DOCUMENTS

EM 004594836-0001 * 1/2018

* cited by examiner

Primary Examiner — Karen S Acker

Assistant Examiner — Steven B Reinholdt, Jr.

(74) *Attorney, Agent, or Firm* — Thompson Coburn LLP

(57) **CLAIM**

The ornamental design for a bottle cap, as shown and described.

DESCRIPTION

FIG. 1 is a first perspective view of the bottle cap showing our new design;

FIG. 2 is a second perspective view thereof;

FIG. 3 is a front view thereof;

FIG. 4 is a rear view thereof;

FIG. 5 is a left side view thereof;

FIG. 6 is a right side view thereof;

FIG. 7 is an enlarged top view thereof; and,

FIG. 8 is an enlarged bottom view thereof.

The broken lines depict portions of the bottle cap that form no part of the claimed design. The dot dash dot broken line is an unclaimed feature line that serves as a boundary to the claim. The broken lines below the dot dash dot broken line illustrating a bottle is environment that forms no part of the claimed design.

1 Claim, 8 Drawing Sheets

(56) **References Cited**
U.S. PATENT DOCUMENTS

D385,792 S *	11/1997	Sayers	D9/448
D451,023 S *	11/2001	Kitamura	D9/449
D530,609 S *	10/2006	Beaver	D9/445
D547,184 S *	7/2007	Kim	D9/447
D589,743 S *	4/2009	Pearson	D7/392
7,712,618 B2 *	5/2010	Barre	B65D 47/0871
				215/237
D655,581 S *	3/2012	Kotani	D7/608
D675,060 S *	1/2013	Lane	D7/392.1
D686,040 S *	7/2013	Lane	D7/510
D686,871 S *	7/2013	Lane	D7/392.1

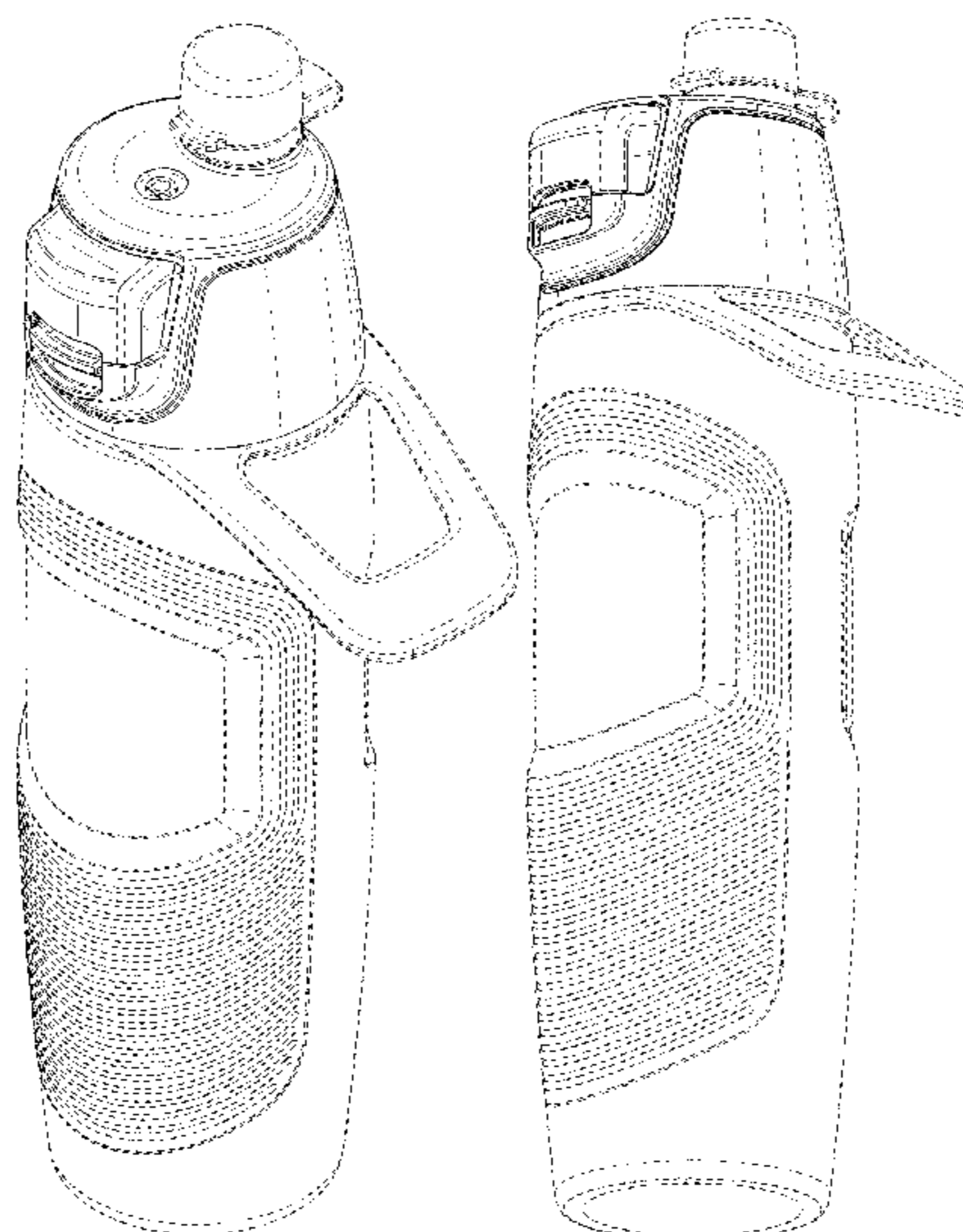

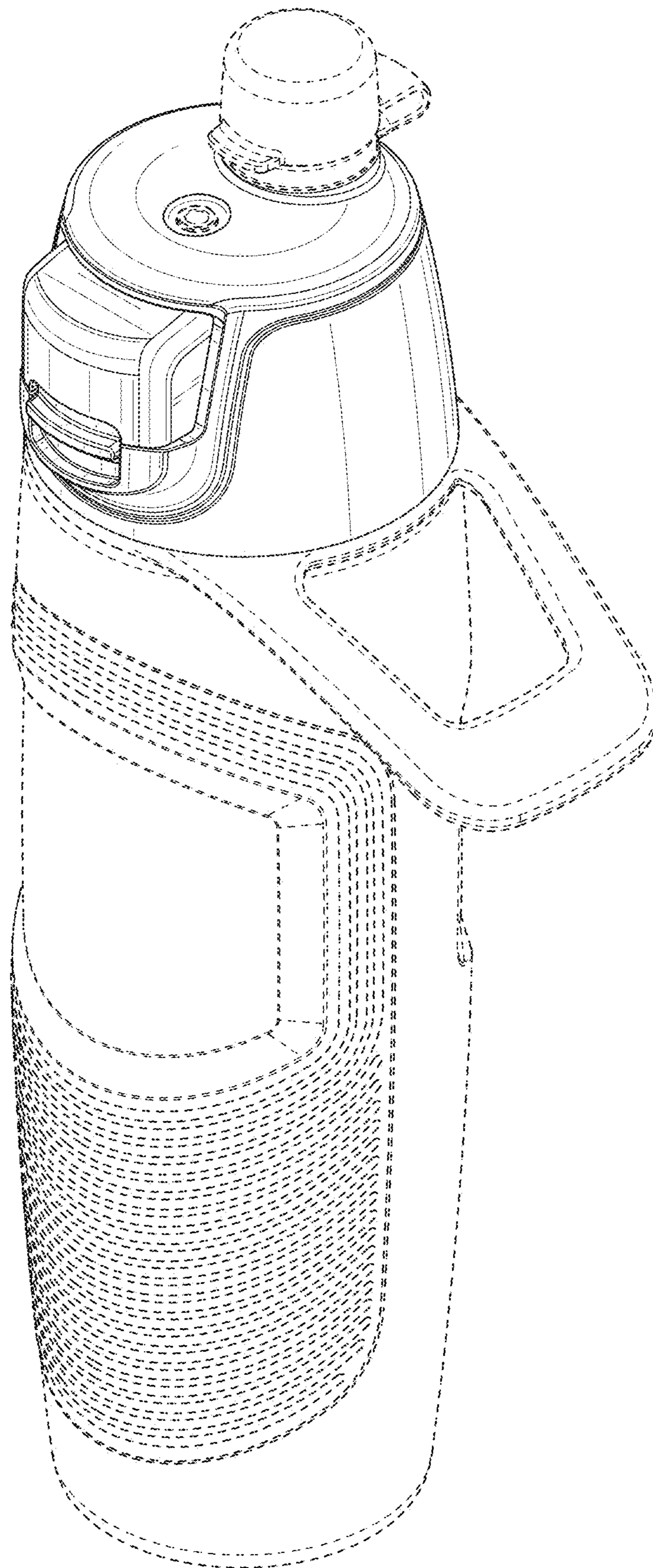

FIG. 1

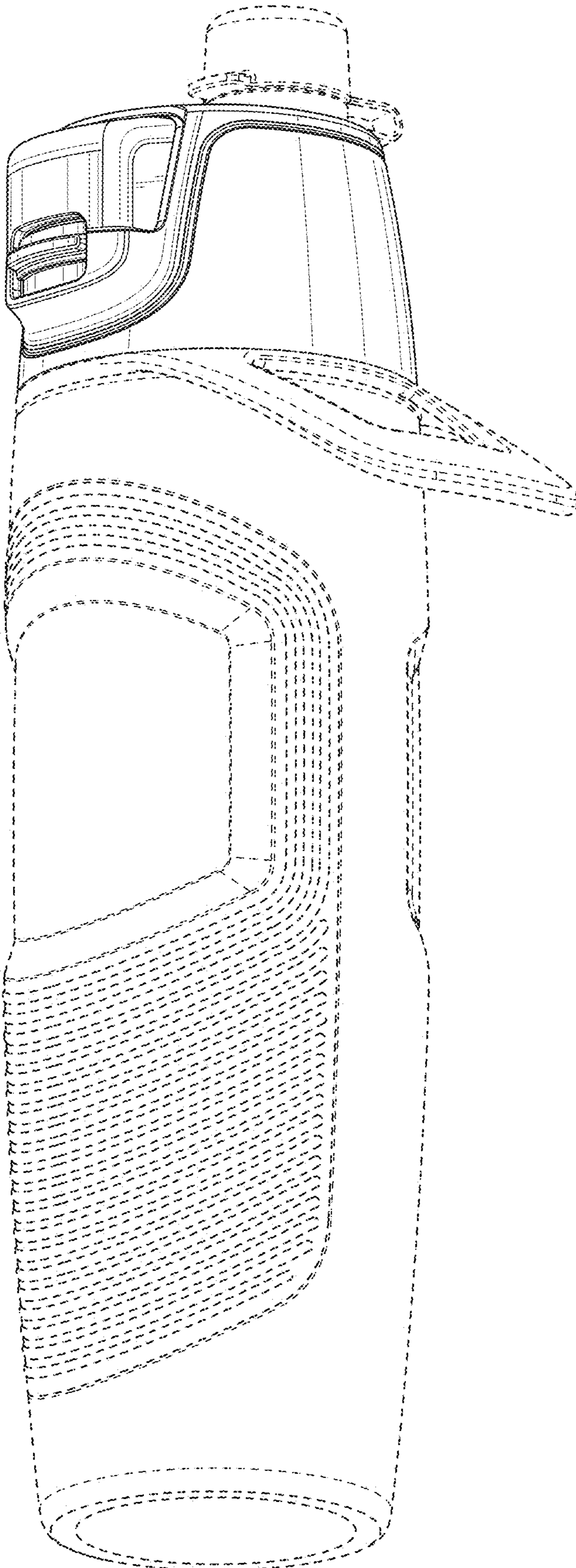

FIG. 2

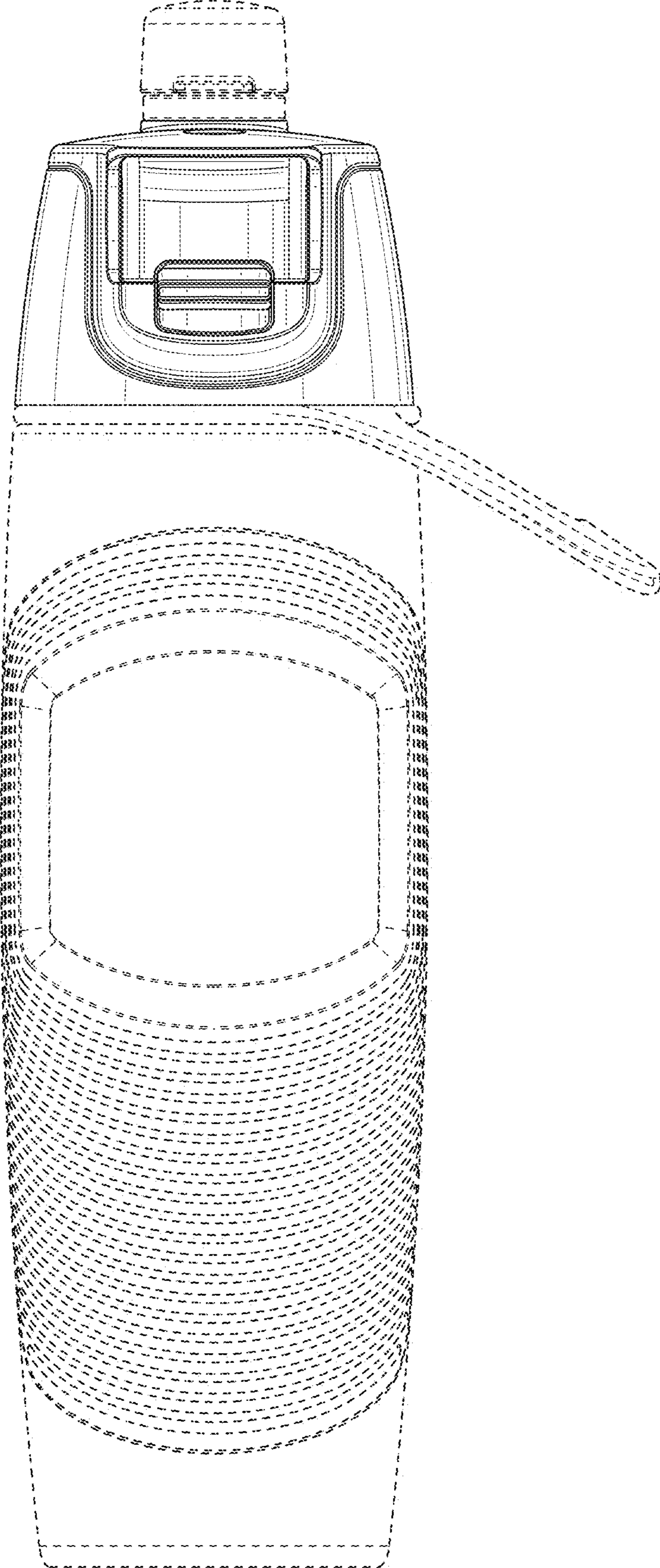

FIG. 3

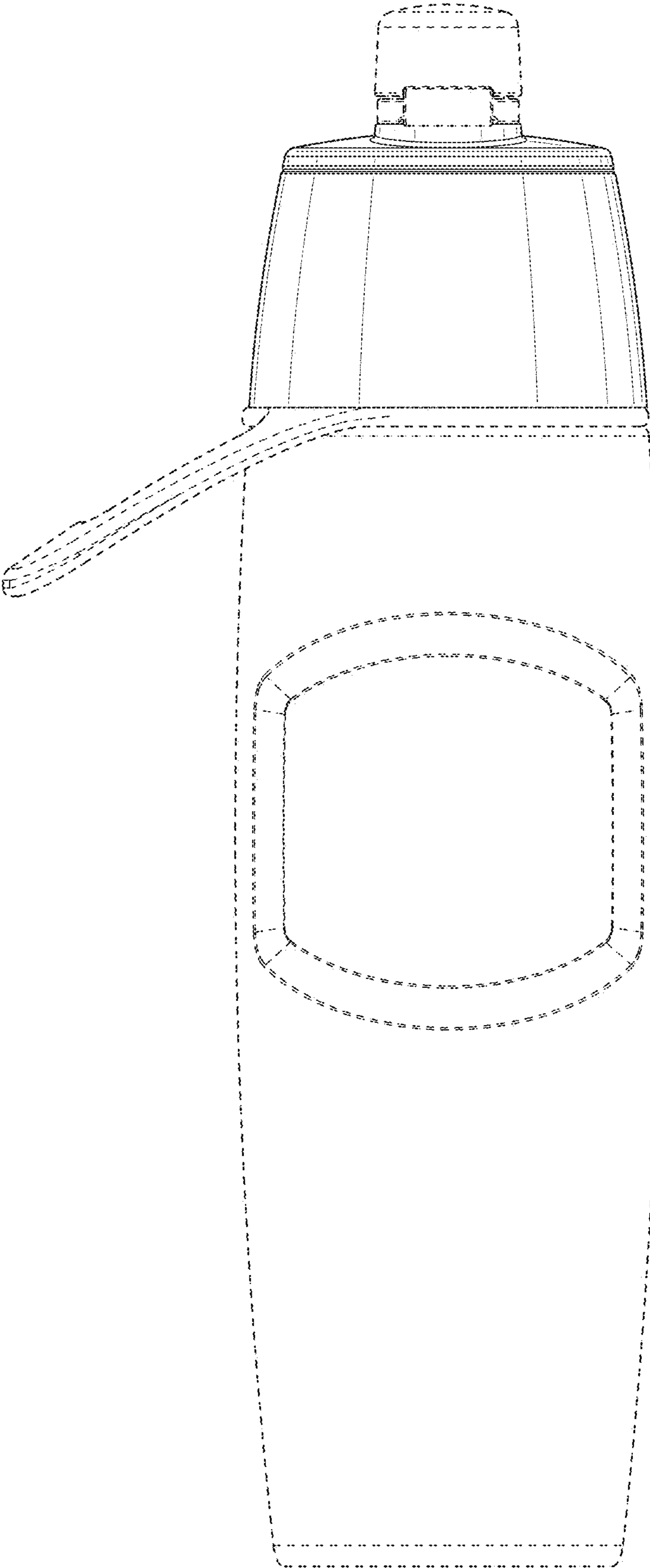

FIG. 4

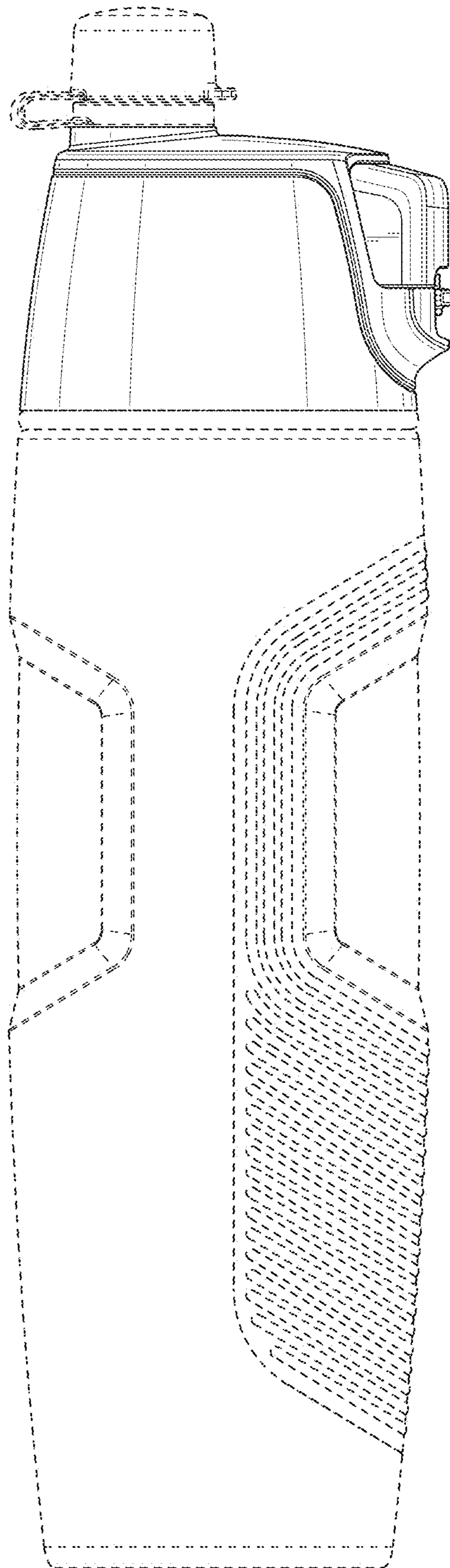

FIG. 5

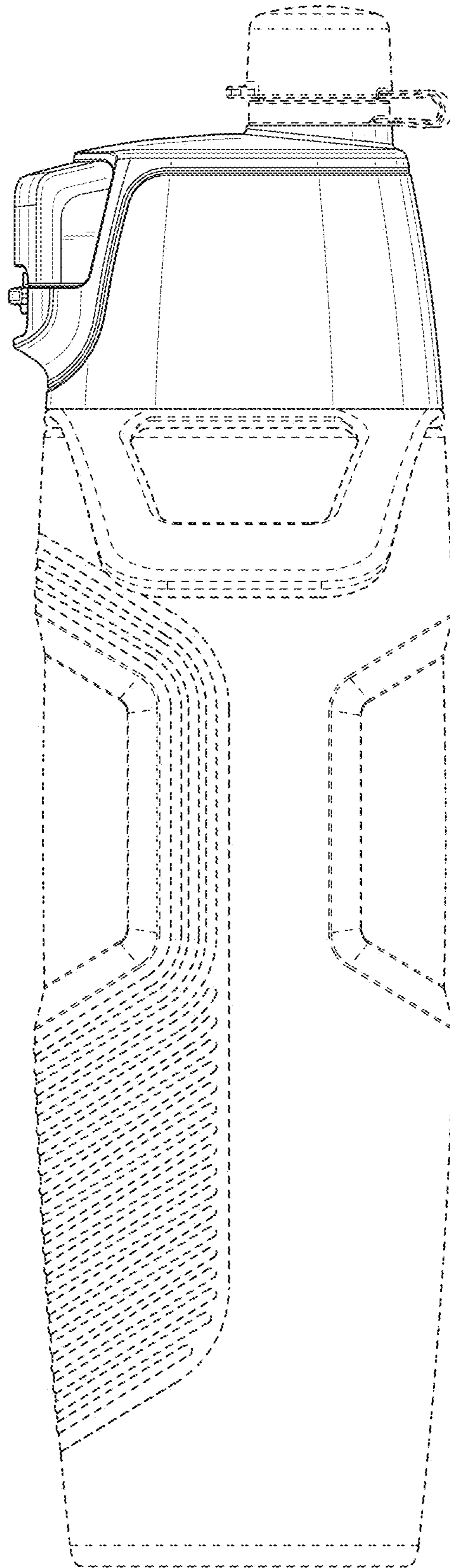

FIG. 6

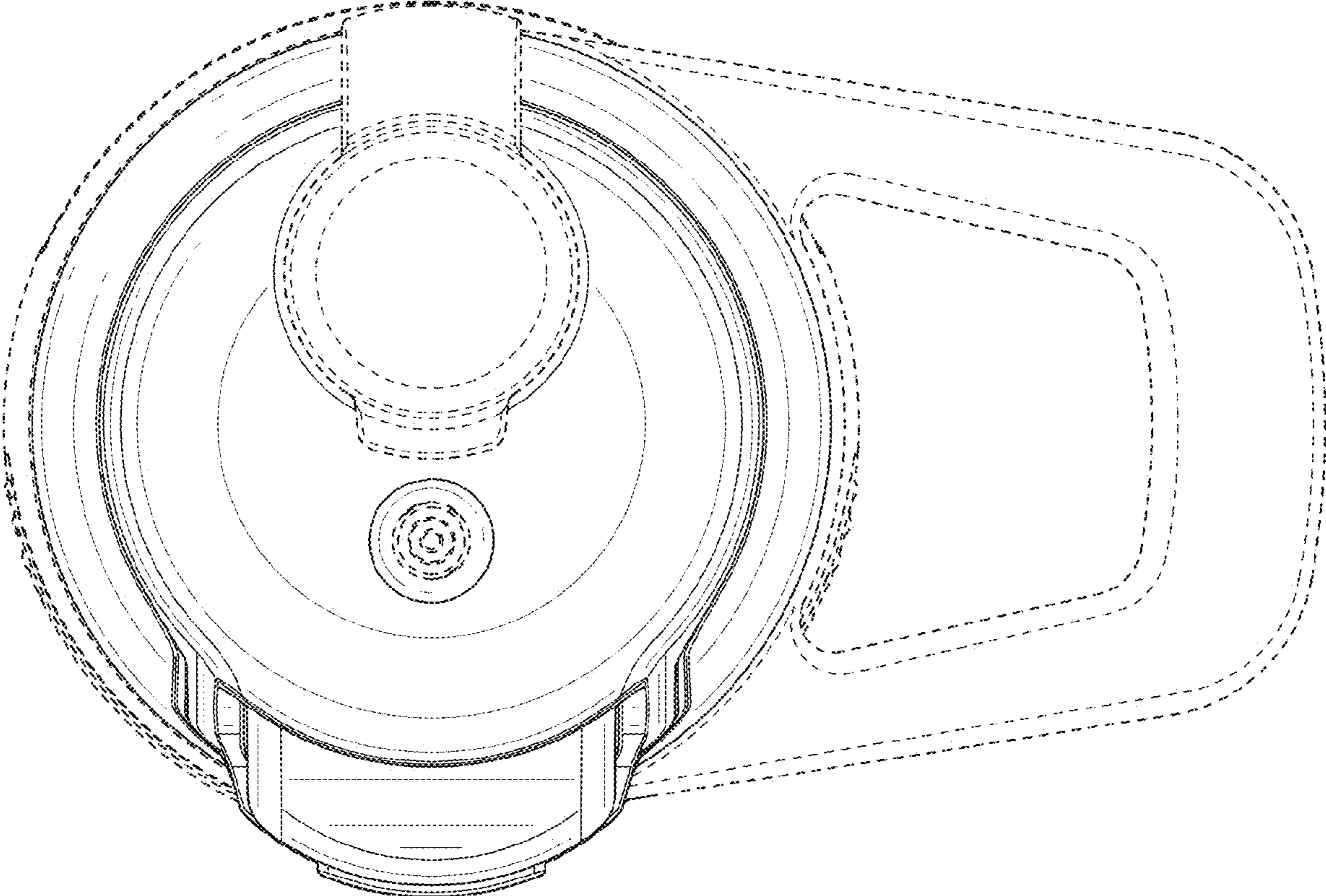

FIG. 7

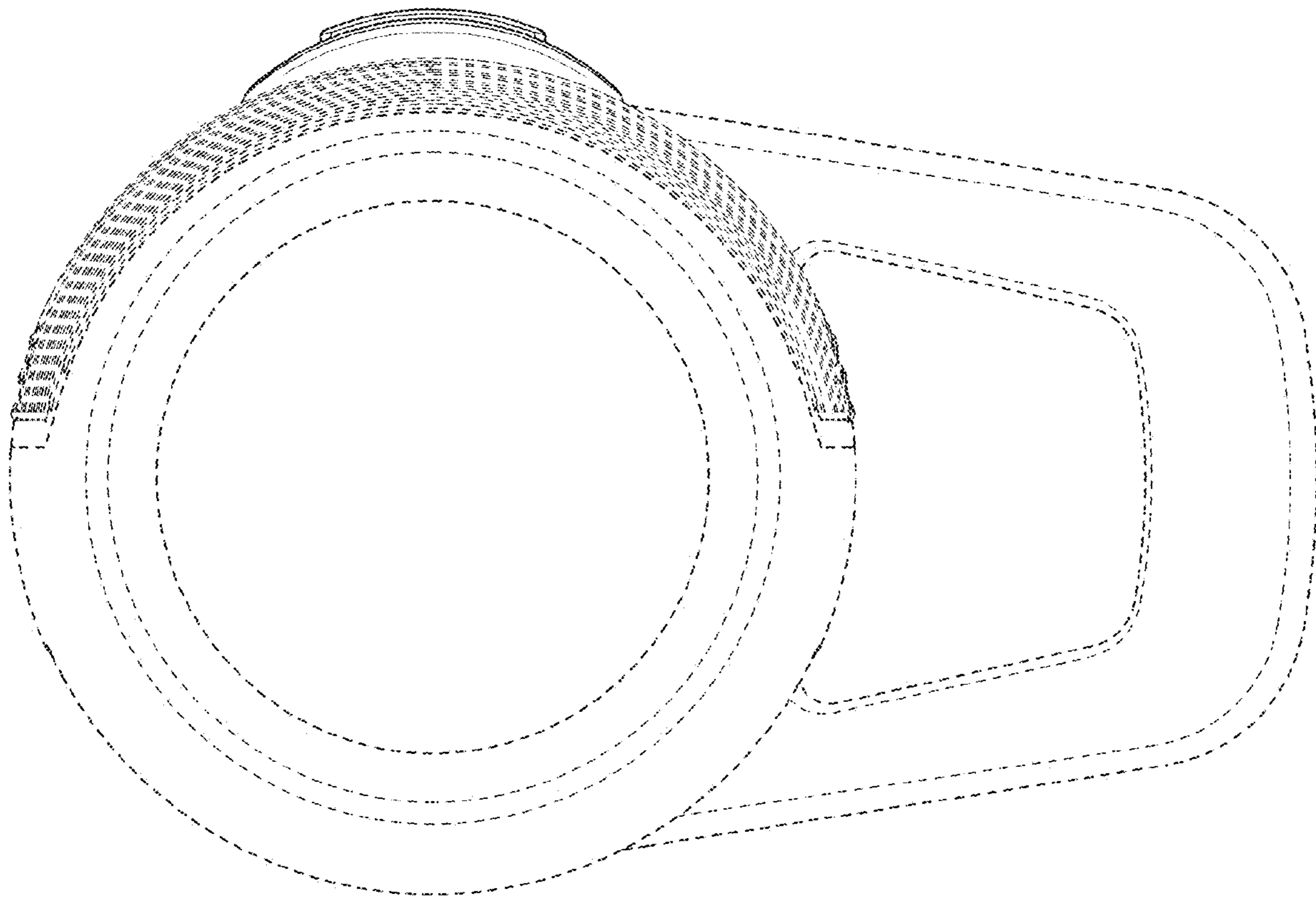

FIG. 8