



US00D873860S

(12) **United States Design Patent** (10) **Patent No.:** **US D873,860 S**
Arizpe et al. (45) **Date of Patent:** **** Jan. 28, 2020**

(54) **MOUNTING BRACKET FOR MANIFOLD ASSEMBLY**

FOREIGN PATENT DOCUMENTS

(71) Applicant: **S.P.M. Flow Control, Inc.**, Fort Worth, TX (US)

AU 1320088 A 9/1988
AU 649744 6/1994
(Continued)

(72) Inventors: **Ron Arizpe**, Fort Worth, TX (US);
Adam Hardman, Fort Worth, TX (US);
Peter Walter, Fort Worth, TX (US)

OTHER PUBLICATIONS

“Written Opinion for Application No. PCT/US2016/37391 by ISA/US dated Sep. 9, 2016, 8 pages.”
(Continued)

(73) Assignee: **S.P.M. Flow Control, Inc.**, Fort Worth, TX (US)

Primary Examiner — T Chase Nelson

Assistant Examiner — Ania Aman

(**) Term: **15 Years**

(74) *Attorney, Agent, or Firm* — Foley & Lardner LLP

(21) Appl. No.: **29/571,208**

(22) Filed: **Jul. 15, 2016**

(57) **CLAIM**

Related U.S. Application Data

The ornamental design for a mounting bracket for manifold assembly, as shown and described.

(63) Continuation of application No. 14/319,010, filed on Jun. 30, 2014, now Pat. No. 9,568,138.

(51) **LOC (12) Cl.** **15-01**

(52) **U.S. Cl.**
USPC **D15/5**

DESCRIPTION

(58) **Field of Classification Search**
USPC D15/1, 2, 3, 4, 5; D8/349, 354, 355, D8/363, 366, 371, 373, 380, 381, 382, D8/499; D12/223; D25/68; D23/322, D23/341, 259, 266, 233, 235
CPC F01M 5/002; F28F 9/007; F28F 9/0075; F28F 9/0131; F28D 2021/0089; F16L 41/02; F16L 3/08; F16L 3/00
See application file for complete search history.

FIG. 1 is a perspective view of a mounting bracket for manifold assembly showing our new design;
FIG. 2 is a top plan view thereof;
FIG. 3 is a right side elevational view thereof;
FIG. 4 is another perspective view thereof that is identical to FIG. 1, except that the depiction in broken lines of unclaimed environmental structure has been omitted;
FIG. 5 is another top plan view thereof that is identical to FIG. 2, except that the depiction in broken lines of unclaimed environmental structure has been omitted; and,
FIG. 6 is another right side elevational view thereof that is identical to FIG. 3, except that the depiction in broken lines of unclaimed environmental structure has been omitted.
The broken lines in FIGS. 1-3 form no part of the claimed design.

(56) **References Cited**

U.S. PATENT DOCUMENTS

345,420 A 7/1886 Eskholme et al.
375,464 A 12/1887 Thacher et al.

(Continued)

1 Claim, 5 Drawing Sheets

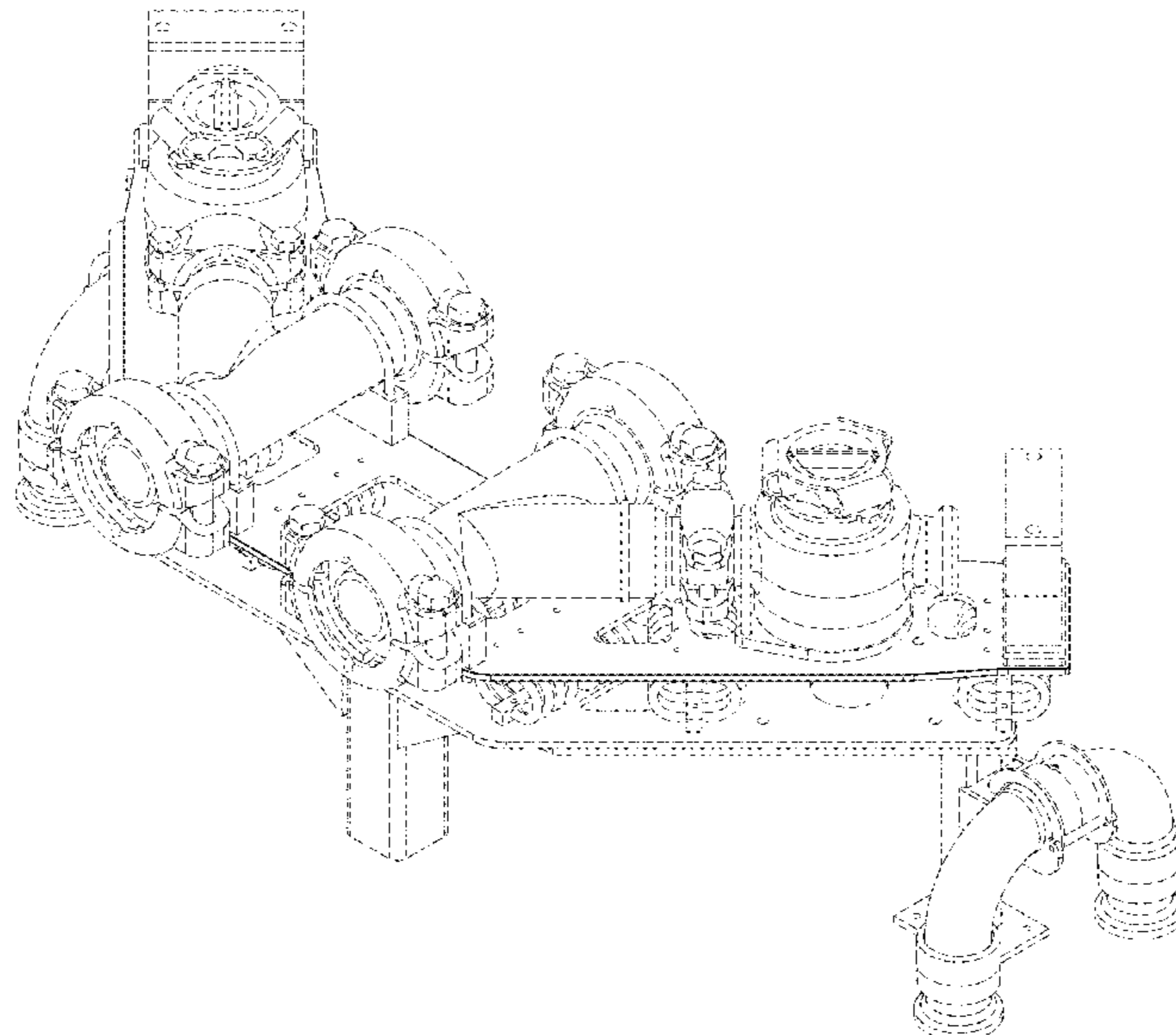

(56)

References Cited

U.S. PATENT DOCUMENTS

417,477 A *	12/1889	Dundon	A63H 19/15 15/54	3,556,474 A	1/1971	Scaramucci	
580,226 A	4/1897	Sanford		3,561,727 A	2/1971	Scaramucci	
741,477 A	10/1903	Flinn		3,571,896 A	3/1971	Wilkerson	
1,201,022 A	10/1916	Conniff		3,594,835 A	7/1971	Wilson	
1,379,092 A	5/1921	Fraccascia et al.		3,630,483 A	12/1971	Canalizo	
1,452,603 A	4/1923	Himes		3,680,188 A	8/1972	Mason et al.	
1,473,634 A	11/1923	Loudon		3,687,415 A	8/1972	Turkot	
1,483,001 A	2/1924	Kurre		3,712,585 A	1/1973	Grenier	
1,488,211 A	3/1924	Loeffler		3,726,314 A	4/1973	Moen	
1,543,637 A	6/1925	Woll		3,789,872 A	2/1974	Elliott	
1,607,463 A	11/1926	Kent		D231,430 S *	4/1974	Steinhauser	D25/48.8
1,664,493 A	4/1928	Smith		3,813,733 A	6/1974	Flohr	
1,675,808 A	7/1928	Kliss		3,830,306 A	8/1974	Brown	
1,764,936 A	6/1930	Dean		3,840,048 A	10/1974	Moen	
1,798,498 A	3/1931	Riley		3,845,876 A	11/1974	Needham et al.	
D86,952 S	5/1932	Garrison		3,845,879 A	11/1974	Dernbach et al.	
1,889,256 A	11/1932	Lipscomb et al.		3,881,480 A	5/1975	Lafourcade	
1,990,090 A	2/1935	Packard		3,894,718 A	7/1975	Koch et al.	
2,197,320 A	4/1940	Shenton		3,901,259 A	8/1975	Banbury	
2,310,583 A	2/1943	Johnson		3,916,950 A	11/1975	Mongerson et al.	
2,310,813 A	2/1943	Sellmeyer		3,933,172 A	1/1976	Allen	
2,339,287 A	1/1944	Neef, Jr.		3,934,608 A	1/1976	Guyton	
2,354,161 A	7/1944	Waterman		3,937,240 A	2/1976	Nanny	
2,361,881 A	10/1944	Sheppard		3,942,551 A	3/1976	Schuller et al.	
2,391,266 A	12/1945	Parker		3,967,842 A	7/1976	Kendrick	
2,404,142 A	7/1946	Parker		3,972,364 A	8/1976	Brumm	
D150,466 S	8/1948	Schuler		3,974,848 A	8/1976	Wheatley	
2,506,162 A	5/1950	Metzgar		4,022,427 A	5/1977	Read	
2,576,431 A	11/1951	White		4,027,696 A	6/1977	Guyton	
2,587,212 A	2/1952	Placette		4,046,164 A	9/1977	Pool	
2,589,144 A	3/1952	Russell et al.		4,059,872 A	11/1977	Delesandri	
2,606,068 A	8/1952	Bonacor		4,085,770 A	4/1978	Woronowicz	
2,612,340 A	9/1952	Laurent		4,086,803 A	5/1978	Wheeler	
2,663,458 A	12/1953	MacGlashan, Jr.		4,093,180 A	6/1978	Strabala	
2,666,508 A *	1/1954	Nardulli	E06B 3/9688 403/295	4,109,714 A	8/1978	Greenlee et al.	
2,694,503 A	11/1954	Young et al.		4,113,228 A	9/1978	Frye	
2,717,001 A	9/1955	Perrault		4,146,047 A	3/1979	Wood et al.	
2,746,773 A	5/1956	Bily		4,150,847 A	4/1979	De Cenzo	
2,766,999 A	10/1956	Watts et al.		4,158,510 A	6/1979	Smith et al.	
2,785,035 A *	3/1957	Hammer	F16B 12/50 312/265.1	4,171,095 A	10/1979	Filan et al.	
2,795,459 A	6/1957	Cornelius		4,218,080 A	8/1980	Kendrick	
2,923,317 A	2/1960	McInerney		4,221,204 A	9/1980	Meyer	
2,925,827 A	2/1960	Anderson et al.		4,236,847 A *	12/1980	Yasuda	A47G 1/10 40/784
2,969,492 A	1/1961	Wheatley		4,254,793 A	3/1981	Scaramucci	
3,024,047 A	3/1962	Schmohl		4,261,387 A	4/1981	Cohn	
3,060,961 A	10/1962	Conley		4,274,434 A	6/1981	Haefele	
3,061,267 A	10/1962	Hamer		4,286,621 A	9/1981	Glahn	
3,064,940 A	11/1962	Anderson et al.		4,308,916 A	1/1982	Fritz, Jr.	
3,072,379 A	1/1963	Hamer		4,321,945 A	3/1982	Chabat-Courrede	
3,108,939 A	10/1963	Sabins		4,327,768 A	5/1982	Behle	
3,113,792 A	12/1963	Brown		4,332,370 A	6/1982	Williams	
3,150,681 A	9/1964	Hansen et al.		4,338,707 A	7/1982	Byerly	
3,160,426 A	12/1964	Faeser		4,367,571 A	1/1983	Speirs et al.	
3,194,589 A	7/1965	Kahlbau et al.		4,378,849 A	4/1983	Wilks	
3,204,484 A	9/1965	Gustafson et al.		4,399,830 A	8/1983	Brodie	
3,216,746 A	11/1965	Watts		4,445,255 A	5/1984	Olejak	
3,228,334 A	1/1966	Oss		4,448,148 A	5/1984	Gain, Jr.	
3,238,687 A	3/1966	Tisbo		4,478,388 A	10/1984	George	
3,241,567 A	3/1966	Pusch et al.		4,485,530 A	12/1984	Begley et al.	
3,294,425 A	12/1966	Franck		4,485,843 A	12/1984	Wolff	
3,341,232 A	9/1967	Deakins		4,497,344 A	2/1985	Kisiel	
3,343,802 A	9/1967	Schuilwerve		4,501,291 A	2/1985	Siegrist	
3,346,002 A	10/1967	Thompson, Jr. et al.		4,506,696 A	3/1985	Von Pechmann	
3,357,679 A	12/1967	Gulick		4,511,120 A	4/1985	Conley et al.	
3,403,931 A	10/1968	Crain et al.		4,524,599 A	6/1985	Bailey	
3,404,698 A	10/1968	Rouse		4,531,542 A	7/1985	Looney	
3,425,661 A	2/1969	Mayo		4,572,237 A	2/1986	Thompson	
3,439,897 A	4/1969	Priese et al.		4,590,957 A	5/1986	McFarlane	
3,455,534 A	7/1969	Scaramucci		4,597,505 A	7/1986	Mozley et al.	
3,467,224 A	9/1969	Curtis et al.		4,605,036 A	8/1986	Smith et al.	
3,472,479 A	10/1969	Sherwood		4,616,803 A	10/1986	Schils	
3,554,581 A	1/1971	Mason et al.		4,634,154 A	1/1987	Arora et al.	
				4,662,603 A	5/1987	Etheridge	
				4,667,570 A	5/1987	Jensen, Jr. et al.	
				4,705,306 A	11/1987	Guido et al.	
				4,716,930 A	1/1988	Richmond et al.	
				4,732,215 A	3/1988	Hopper	
				4,836,240 A	6/1989	Elliott	

(56)

References Cited

U.S. PATENT DOCUMENTS

4,842,014 A	6/1989	Strelow et al.	6,554,249 B2	4/2003	Pang et al.
4,848,398 A	7/1989	Leach	6,742,538 B1	6/2004	Aderholt et al.
4,850,392 A	7/1989	Crump et al.	6,752,377 B1	6/2004	Taylor
4,864,696 A	9/1989	Mittermaier et al.	6,770,177 B2	8/2004	Keller et al.
4,896,367 A	1/1990	Newton et al.	6,843,265 B2	1/2005	Taylor
4,915,418 A	4/1990	Palatchy	6,848,724 B2	2/2005	Kessler
4,969,482 A	11/1990	Perrin et al.	6,854,704 B1	2/2005	Young
4,993,489 A	2/1991	McLeod	6,880,567 B2	4/2005	Klaver et al.
5,025,865 A	6/1991	Caldwell et al.	6,880,568 B1	4/2005	Taylor
5,046,525 A	9/1991	Powell	6,886,593 B2	5/2005	Madden et al.
5,056,548 A	10/1991	Mills	6,945,569 B1	9/2005	Diaz et al.
5,143,112 A	9/1992	Scaramucci	6,948,526 B2	9/2005	Seder et al.
5,161,566 A	11/1992	Scaramucci	6,954,569 B2	10/2005	Yang
5,161,570 A	11/1992	Scaramucci	6,978,799 B2	12/2005	Kugelev et al.
5,165,478 A	11/1992	Wilson	7,004,445 B2	2/2006	Lymberopoulos
5,178,185 A	1/1993	Stehling et al.	7,028,778 B2	4/2006	Krywitsky
5,199,464 A	4/1993	Savard	7,028,986 B2	4/2006	Young
5,199,681 A *	4/1993	Reidy A47G 1/0638 248/216.1	7,135,447 B1 *	11/2006	Bowsman C10L 1/143 510/185
5,307,835 A	5/1994	Scaramucci	7,204,525 B2	4/2007	Matzner
5,341,840 A	8/1994	Manson et al.	7,207,399 B2	4/2007	Duhe
5,386,847 A	2/1995	Scaramucci	RE39,695 E	6/2007	Ungchusri et al.
5,417,402 A	5/1995	Speybroeck	7,228,869 B2	6/2007	Wilhelm
D360,728 S	7/1995	Nozaki	D549,850 S	8/2007	Perlman
5,439,027 A	8/1995	Layton et al.	7,264,059 B2	9/2007	Akselberg
5,441,072 A	8/1995	Indey et al.	7,285,190 B2	10/2007	Martin et al.
5,443,088 A	8/1995	Hoch et al.	7,302,961 B2	12/2007	Martin et al.
5,462,413 A	10/1995	Schroeder	D570,501 S	6/2008	Janesz et al.
5,477,752 A	12/1995	West et al.	7,398,796 B2	7/2008	Hjorth et al.
5,507,533 A	4/1996	Mumma	7,401,819 B2	7/2008	Gibb et al.
5,522,420 A	6/1996	Martin	7,451,959 B2	11/2008	Matzner
5,526,883 A	6/1996	Breaux	7,458,212 B2	12/2008	Koizumi et al.
5,538,296 A	7/1996	Horton	7,516,941 B2	4/2009	Combs
5,544,675 A	8/1996	Dean	7,549,681 B1	6/2009	Matzner
5,584,315 A	12/1996	Powell	7,677,526 B2	3/2010	Lymberopoulos
5,603,485 A	2/1997	Schwarz	7,819,386 B2	10/2010	Combs
5,638,765 A *	6/1997	Poulos B63H 20/34 114/274	7,823,265 B2	11/2010	Matzner et al.
D380,958 S *	7/1997	Beard, Jr. D25/102	7,890,276 B2	2/2011	Killion et al.
5,676,348 A	10/1997	Ungchusri et al.	7,950,409 B2	5/2011	Stokes et al.
5,685,334 A	11/1997	Hagan	8,000,909 B2	8/2011	Danzy
5,689,862 A	11/1997	Hayes et al.	8,051,875 B2	11/2011	Edwards et al.
5,755,427 A	5/1998	Koskinas	8,146,665 B2	4/2012	Neal
5,774,922 A *	7/1998	Bumb A46B 9/02 15/159.1	8,151,885 B2	4/2012	Bull
5,787,926 A	8/1998	Mukumoto et al.	D660,461 S	5/2012	Kotin et al.
5,791,693 A	8/1998	Crawford	D660,984 S	5/2012	Kotin et al.
D400,080 S *	10/1998	Beard, Jr. D8/354	8,196,229 B1	6/2012	Hickok
5,832,947 A	11/1998	Niemczyk	D666,326 S	8/2012	Sims
D414,400 S *	9/1999	Williams D8/354	8,261,771 B2	9/2012	Witkowski et al.
5,947,152 A	9/1999	Martin et al.	D675,750 S	2/2013	King
5,957,592 A	9/1999	Yamanaka	8,376,046 B2	2/2013	Broussard, II
5,971,007 A	10/1999	Harcourt et al.	8,465,001 B2	6/2013	Witkowski et al.
5,983,826 A	11/1999	Lohde	8,469,108 B2	6/2013	Kajaria et al.
6,003,837 A	12/1999	Raymond, Jr. et al.	8,474,521 B2	7/2013	Kajaria et al.
6,029,693 A	2/2000	Nakanishi et al.	8,490,949 B2	7/2013	Lanning et al.
6,079,439 A	6/2000	Hartley	D693,078 S *	11/2013	Nordvik D32/50
6,082,707 A	7/2000	Hosie et al.	8,590,614 B2	11/2013	Surjaatmadja
6,085,572 A	7/2000	McGuire, Sr. et al.	D703,294 S	4/2014	Witkowski et al.
6,089,531 A	7/2000	Young	8,695,627 B2	4/2014	Kugelev et al.
6,155,091 A	12/2000	Hayes et al.	D707,332 S	6/2014	Witkowski et al.
6,164,707 A	12/2000	Ungchusri et al.	D707,797 S	6/2014	Witkowski et al.
6,171,043 B1 *	1/2001	Williams F16B 15/0046 403/283	8,833,804 B2	9/2014	Myers et al.
6,209,561 B1	4/2001	Kugelev et al.	8,870,233 B2	10/2014	Matzner et al.
6,230,733 B1	5/2001	Strelow et al.	8,978,695 B2	3/2015	Witkowski et al.
6,240,951 B1	6/2001	Yori	8,978,763 B2	3/2015	Guidry
6,250,605 B1	6/2001	Young	8,998,168 B2	4/2015	Witkowski
6,290,237 B1	9/2001	Graupner	D734,434 S	7/2015	Witkowski et al.
6,361,051 B1	3/2002	Babin	9,103,448 B2	8/2015	Witkowski et al.
6,371,527 B1	4/2002	Ungchusri et al.	9,127,545 B2	9/2015	Hokey
6,382,247 B1	5/2002	Gundry	9,273,543 B2	3/2016	Baca et al.
6,387,226 B1	5/2002	Persson	9,322,243 B2	4/2016	Baca et al.
6,450,477 B1	9/2002	Young	2002/0179876 A1	12/2002	Pang et al.
6,554,024 B2	4/2003	Mefford et al.	2002/0185867 A1	12/2002	Stachowiak
			2002/0186910 A1	12/2002	Maret
			2003/0047944 A1	3/2003	Ungchusri et al.
			2003/0178067 A1	9/2003	Fredrickson et al.
			2004/0163716 A1	8/2004	Madden et al.
			2005/0087232 A1	4/2005	Kugelev et al.
			2005/0121073 A1	6/2005	Carroll
			2005/0199286 A1	9/2005	Appleford et al.

(56)

References Cited

U.S. PATENT DOCUMENTS

2006/0091339 A1 5/2006 Young
 2006/0185731 A1 8/2006 Grable et al.
 2006/0266422 A1 11/2006 Feenstra et al.
 2006/0278394 A1 12/2006 Stover
 2006/0283513 A1 12/2006 Kurian et al.
 2007/0029090 A1 2/2007 Andreychuk et al.
 2007/0051411 A1 3/2007 Scaramucci et al.
 2007/0205387 A1 9/2007 Grau et al.
 2007/0262029 A1 11/2007 Yoshida et al.
 2007/0272308 A1 11/2007 Spears et al.
 2008/0039802 A1 2/2008 Vangsness et al.
 2008/0054204 A1 3/2008 Zhou
 2008/0142752 A1 6/2008 Matzner
 2008/0196773 A1 8/2008 Franconi
 2008/0264649 A1 10/2008 Crawford
 2008/0295910 A1 12/2008 Aleksandersen et al.
 2008/0308159 A1 12/2008 Stunkard
 2009/0120635 A1 5/2009 Neal
 2010/0154894 A1 6/2010 Kotapish et al.
 2010/0193057 A1 8/2010 Garner et al.
 2010/0258200 A1 10/2010 Walker et al.
 2010/0288493 A1 11/2010 Fielder et al.
 2010/0300672 A1 12/2010 Childress
 2011/0036415 A1 2/2011 Lymberopoulos
 2011/0048695 A1 3/2011 Cherewyk
 2011/0061871 A1 3/2011 Omvik
 2011/0125332 A1 5/2011 Heitman
 2011/0126930 A1 6/2011 Hayashi
 2011/0240126 A1 10/2011 Lymberopoulos et al.
 2011/0259584 A1 10/2011 Broussard
 2011/0272158 A1 11/2011 Neal
 2011/0316274 A1 12/2011 Groenlund et al.
 2012/0025114 A1 2/2012 Lymberopoulos et al.
 2012/0031494 A1 2/2012 Lymberopoulos
 2012/0060929 A1 3/2012 Kendrick
 2012/0073670 A1 3/2012 Lymberopoulos
 2012/0085541 A1 4/2012 Love et al.
 2012/0091743 A1 4/2012 Ohman, III et al.
 2012/0181013 A1 7/2012 Kajaria et al.
 2012/0181015 A1 7/2012 Kajaria et al.
 2012/0181016 A1 7/2012 Kajaria et al.
 2012/0181046 A1 7/2012 Kajaria et al.
 2012/0219354 A1 8/2012 Bauer et al.
 2012/0227983 A1 9/2012 Lymberopoulos et al.
 2012/0255734 A1 10/2012 Coli et al.
 2012/0298213 A1 11/2012 Forster et al.
 2012/0325332 A1 12/2012 Ball et al.
 2013/0020519 A1 1/2013 Lymberopoulos
 2013/0032328 A1 2/2013 Guidry
 2013/0037125 A1 2/2013 Drake et al.
 2013/0126152 A1 5/2013 Banks et al.
 2013/0248182 A1 9/2013 Chong et al.
 2013/0284455 A1 10/2013 Kajaria
 2013/0328301 A1 12/2013 McGuire
 2014/0318777 A1 10/2014 Fontenelle
 2015/0000766 A1 1/2015 Arizpe et al.
 2015/0042088 A1 2/2015 Witkowski et al.
 2015/0292297 A1 10/2015 Kajaria
 2015/0300545 A1 10/2015 Hayashi
 2015/0337861 A1 11/2015 Hokey
 2015/0345646 A1 12/2015 Witkowski et al.
 2016/0161956 A1 6/2016 Baca et al.
 2017/0370199 A1* 12/2017 Witkowski E21B 33/038

FOREIGN PATENT DOCUMENTS

AU 348253 5/2013
 CA 2350047 A1 12/2001
 CA 2635751 A1 12/2001
 CA 2636751 A1 1/2009
 CA 2490664 C 11/2009
 CA 2485817 C 8/2010
 CA 2654848 A1 8/2010
 CA 2503231 C 6/2011
 CA 2612397 C 4/2013

CA 149748 11/2014
 CA 152956 11/2014
 CA 152957 11/2014
 CA 2764310 C 6/2015
 CN 2118877 U 10/1992
 CN 1137309 A 12/1996
 CN 1225298 A 8/1999
 CN 2426550 Y 4/2001
 CN 1548701 A 11/2004
 CN 1908365 A 2/2007
 CN 2901281 Y 5/2007
 CN 200999609 Y 1/2008
 CN 201043685 Y 4/2008
 CN 101205798 A 6/2008
 CN 101258350 A 9/2008
 CN 101303033 A 11/2008
 CN 201162522 Y 12/2008
 CN 101367099 A 2/2009
 CN 201206648 Y 3/2009
 CN 201262043 Y 6/2009
 CN 101539218 A 9/2009
 CN 101722221 A 6/2010
 CN 201496006 U 6/2010
 CN 201545914 U 8/2010
 CN 201650157 U 11/2010
 CN 201739525 U 2/2011
 CN 201747313 U 2/2011
 CN 202031536 U 11/2011
 CN 202047762 U 11/2011
 CN 102323158 A 1/2012
 CN 202144943 2/2012
 CN 202208237 U 5/2012
 CN 202255848 U 5/2012
 CN 202255937 U 5/2012
 CN 202718658 2/2013
 CN ZL2013300399164 9/2013
 CN ZL201330441389 4/2014
 CN ZL2010800253503 5/2014
 CN ZL2013304412416 5/2014
 DE 1166571 B 3/1964
 DE 2415732 A1 10/1974
 DE 2358756 A1 3/1975
 DE 2558272 A1 7/1977
 DE 2642743 A1 3/1978
 DE 218416 A1 2/1985
 DE 3341643 A1 5/1985
 DE 19707228 A1 8/1998
 DE 102004033453 A1 1/2006
 EA 201171356 A1 5/2012
 EC EU0002185371-001 2/2013
 EC 002307421-0001 9/2013
 EC 002307421-0002 9/2013
 EP 0044619 A1 1/1982
 EP 0559131 B1 1/1996
 EP 1219942 B1 8/2004
 EP 1488867 A1 12/2004
 EP 2438338 4/2015
 FR 2635476 A1 2/1990
 GB 255970 A 8/1926
 GB 578008 A 6/1946
 GB 619950 A 3/1949
 GB 731895 A 6/1955
 GB 1536728 A 12/1978
 GB 2056626 A 3/1981
 GB 2117822 A 10/1983
 GB 2140338 A 11/1984
 GB 2185287 A 7/1987
 GB 2228885 A 9/1990
 GB 2312728 B 5/2000
 GB 2355510 A 4/2001
 GB 2408562 A 1/2005
 GB 2416574 B 8/2008
 GB 2413606 B 3/2009
 GB 2444822 B 6/2011
 GB 2452801 B 4/2012
 GB 2493900 A 2/2013
 GB 2521300 A 6/2015
 IN 251691 8/2012
 JP 53108873 A 9/1978

(56)

References Cited

FOREIGN PATENT DOCUMENTS

JP	53125261	A	11/1978
JP	57073187		5/1982
JP	57079400		5/1982
JP	61093344		5/1986
JP	5033883	A	2/1993
JP	08075022		3/1996
JP	08128536		5/1996
JP	08291543		5/1996
JP	08300052		11/1996
JP	10175026		6/1998
JP	2000330646		11/2000
JP	2001355774		12/2001
JP	2002098068		4/2002
JP	2004190769	A	7/2004
JP	2006194334	A	7/2006
JP	D1285004		9/2006
JP	2008215626	A	9/2008
JP	4996990	B2	5/2012
KR	100540389	B1	12/2005
KR	100540390	B1	12/2005
KR	100540392	B1	12/2005
KR	100621158	B1	8/2006
KR	100716760	B1	5/2007
KR	100832065	B1	5/2008
KR	101191630	B1	10/2012
MX	2011011007	A	2/2012
MX	40533		12/2013
MX	324905		10/2014
NL	258255	A	4/1964
RU	1466084	C	6/1995
RU	1417281	C	7/1995
RU	2088831	C1	8/1997
RU	2367770	C1	9/2009
RU	2367771	C1	9/2009
SG	175263		11/2012
SG	176534		11/2012
SU	567001	A1	7/1977
SU	585898	A1	12/1977
SU	1391769	A1	4/1988
SU	1721368	A1	3/1992
WO	9713398	A2	4/1997
WO	9956047	A2	11/1999
WO	2009023042	A1	2/2009
WO	2010080636	A2	7/2010
WO	2010123889	A2	10/2010
WO	2010141651	A2	12/2010

OTHER PUBLICATIONS

“Notice of Allowance dated Nov. 28, 2014, by the USPTO, re U.S. Appl. No. 13/608,562, 36 pages.”

“Notice of Allowance dated Oct. 27, 2015, by the USPTO, re U.S. Appl. No. 13/964,863, 5 pages.”

“Notice of Allowance dated Sep. 23, 2008, by the USPTO, re U.S. Appl. No. 11/638,965, 6 pages.”

“Office Action dated Apr. 25, 2014, by the USPTO, re U.S. Appl. No. 13/608,562, 31 pages.”

“Office Action dated Apr. 30, 2015, by the USPTO, re U.S. Appl. No. 13/886,771, 13 pages.”

“Office Action dated Apr. 4, 2008, by the USPTO, re U.S. Appl. No. 11/638,965, 10 pages.”

“Office Action dated Aug. 16, 2013, by the USPTO, re U.S. Appl. No. 12/822,900, 15 pages.”

“Office Action dated Aug. 30, 2005, by the USPTO, re U.S. Appl. No. 11/013,486, 12 pages.”

“Office Action dated Aug. 9, 2011, by the USPTO, re U.S. Appl. No. 12/165,680, 18 pages.”

“Office Action dated Dec. 22, 2004, by the USPTO, re U.S. Appl. No. 10/833,859, 5 pages.”

“Office Action dated Dec. 30, 1996, by the USPTO, re U.S. Appl. No. 08/643,239, 11 pages.”

“Office Action dated Dec. 6, 2012, by the USPTO, re U.S. Appl. No. 12/822,900, 20 pages.”

“Office Action dated Feb. 2, 2013, by the Russian Patent Office, re App No. 2013500548, 2 pages.”

“Office Action dated Feb. 28, 2014, by the USPTO, re U.S. Appl. No. 12/165,680, 60 pages.”

“Office Action dated Jan. 31, 2012, by the USPTO, re U.S. Appl. No. 12/165,680, 28 pages.”

“Office Action dated Jan. 5, 2015, by the USPTO, re U.S. Appl. No. 13/572,293, 12 pages.”

“Office Action dated Jan. 8, 2010, by the USPTO, re U.S. Appl. No. 11/354,663, 6 pages.”

“Office Action dated Jul. 10, 2015, by the USPTO, re U.S. Appl. No. 13/964,863, 36 pages.”

“Office Action dated Jul. 12, 2013, by the USPTO, re U.S. Appl. No. 12/165,680, 24 pages.”

“Office Action dated Jul. 31, 2014, by the USPTO, re U.S. Appl. No. 13/965,848, 44 pages.”

“Office Action dated Jun. 18, 2014, by the USPTO, re U.S. Appl. No. 13/572,293, 29 pages.”

“Office Action dated Mar. 19, 2012, by the USPTO, re U.S. Appl. No. 12/642,541, 15 pages.”

“Office Action dated Mar. 27, 2014, by the USPTO, re U.S. Appl. No. 13/918,479, 13 pages.”

“Office Action dated May 31, 2011, from the UK IP Office, re App No. GB0812086.7, 2 pages.”

“Office Action dated Nov. 17, 1983, by the USPTO, re U.S. Appl. No. 06/419,141, 4 pages.”

“Office Action dated Oct. 11, 2011, by the USPTO, re U.S. Appl. No. 12/763,786, 9 pages.”

“Office Action dated Oct. 25, 2012, by the USPTO, re U.S. Appl. No. 12/793,194, 8 pages.”

“Office Action dated Sep. 13, 2013, by the USPTO, re U.S. Appl. No. 13/608,562, 12 pages.”

“Office Action dated Mar. 7, 2013, by the USPTO, re U.S. Appl. No. 12/165,680, 23 pages.”

“Office Action dated Nov. 6, 2014, by the USPTO, re U.S. Appl. No. 13/965,848, 12 pages.”

“Oksanen, K. et al, “Singer Model DLA-RPS—Air Operated Surge Anticipating Electrically Timed Sewage Relief Valve; Schematic A-8809A,” Singer Valve, Dec. 8, 2010, XP055159354, 3 pages.”

““Product Data Sheet, 10 Station AFAM Trailer,” FMC Technologies (www.fmctechnologies.com), PDS50002076-A, Oct. 28, 2011, 6 pages.”

Reset Relief Valves brochure, Harrisburg, Inc., 1982, 2 pages.

SPM Flow Control, Inc., “Flow Control Products and Drilling Equipment for the Worldwide Petroleum Industry,” [Online] Jan. 8, 2007, 28 pages.

SPM Flow Control, Inc., “High-Pressure Long Radius Swivel Joints,” 2002, 1 page.

SPM Flow Control, Inc., “Long Radius Swivel Joints—Operating and Maintenance Instructions—H2S,” 1999, 6 pages.

SPM Flow Control, Inc., “Long Radius Swivel Joints—Operating and Maintenance Instructions,” 2004, 4 pages.

SPM Flow Control, Inc., “Long Radius Swivel Joints—Operating and Maintenance Instructions,” 2006, 6 pages.

SPM Flow Control, Inc., “Long Radius Swivel Joints,” 2007, 5 pages.

SPM Flow Control, Inc., “Swivel Joints,” 1999, 1 page.

Supplementary European Search Report for Application No. EP09838004 dated on Jan. 30, 2013, 4 pages.

““The Strength of Screw Threads Under Repeated Tension” by Herbert F. Moore and Proctor E. Henwood, University of Illinois Engineering Experiment Station, Bulletin No. 264, Mar. 1934 (Mar. 1934), 20 pages.”

“U.S. Appl. No. 60/653,014, filed Feb. 15, 2005, “Flowline Torque Arm Assembly,” 16 pages.”

“U.S. Appl. No. 60/947,738, filed Jul. 3, 2007, “Swivel Joint with Uniform Ball Bearing Requirements,” 12 pages.”

“U.S. Appl. No. 61/170,917, filed Apr. 20, 2009, “Flowline Flapper Valve,” 9 pages.”

“U.S. Appl. No. 61/220,067, filed Jun. 24, 2009, “Stand for Pressure Relief Valve,” 12 pages.”

(56)

References Cited

OTHER PUBLICATIONS

“U.S. Appl. No. 61/522,234, filed Aug. 10, 2011, “Rupture Disk Relief Valve,” 23 pages.”
 Valve illustration, Retsco Inc., 1992, 1 page.
 “Weir SPM Safety Iron Manifold Trailer, 2008, 2 pages.”
 ““Windlass Engineers & Services,” Hammer Unions (Windglass Engineers), Mar. 11, 2015, 8 pages.”
 “Advisory Action dated May 20, 2013, by the USPTO, re U.S. Appl. No. 12/165,680, 3 pages.”
 “An Introduction to Rupture Disk Technology,” Catalog 77-1001, BS&B Safety Systems, 1994, 3 pages.
 “Australian Examination Report, dated Sep. 25, 2014, by IP Australia, re App No. 2010239366, 3 pages.”
 “Brazil Office Action, dated Jun. 3, 2014, by Brazilian Patent Office, re App No. BR3020130006611, 2 pages.”
 “Canadian Examination Report dated Apr. 28, 2014, by CIPO, re App No. 2764310, 3 pages.”
 “Canadian Examination Report dated Feb. 10, 2014, by CIPO, re App No. 152956, 3 pages.”
 “Canadian Examination Report dated Feb. 7, 2014, by CIPO, re App No. 149748, 1 page.”
 “Canadian Examination Report dated Jul. 29, 2014, by CIPO, re App No. 2636751, 3 pages.”
 “Canadian Examiner’s Report dated Feb. 10, 2014, by CIPO, re App No. 152957, 3 pages.”
 “Canadian Notice of Allowance dated Dec. 17, 2014, by CIPO, re App No. 2764310, 1 page.”
 “Canadian Notice of Allowance dated Dec. 20, 2012, by CIPO, re App No. 2612397, 1 page.”
 “Canadian Notice of Allowance dated Jun. 22, 2015, by CIPO, re App No. 2636751, 1 page.”
 “Chinese Office Action dated Jun. 5, 2013, by SIPO, re App No. 2010800253503, 8 pages.”
 “Chinese Office Action dated Nov. 11, 2016, by SIPO, re App No. 201380054054, 13 pages.”
 Co-pending U.S. Appl. No. 29/453,837, filed May 3, 2013.
 “Second Written Opinion of the International Preliminary Examining Authority, dated Jul. 28, 2014, By the IPEA/US, re PCT/US2013/054741, 7 pages.”
 Emergency Relief Valve Brochure, SPM, 1997, 4 pages.
 “Eurasian Office Action dated Nov. 19, 2013, by the Eurasian Patent Office, re App No. 201171356/31, 8 pages.”
 “European Examination Report dated Apr. 8, 2014, by the EPO, re App No. 10784052.2, 5 pages.”
 “European Search Report dated Jul. 4, 2013, by the EPO, re App No. 10784052.2, 7 pages.”
 “European Search Report dated Mar. 5, 2013, by the EPO, re App No. 10767632.2, 6 pages.”
 “Examination Report dated Apr. 26, 2013, by IP India, re App No. 251691, 2 pages.”
 “International Preliminary Report on Patentability dated Jul. 15, 2013, by the IPEA/US, re App No. PCT/US2012/050376, 28 pages.”

“International Preliminary Report on Patentability dated Nov. 17, 2014, by the IPEA/US, re App No. PCT/US2013/054741, 31 pages.”
 “International Search Report and Written Opinion dated Dec. 16, 2014, by the ISA/US, re App. No. PCT/US2014/044813, 12 pages.”
 “International Search Report and Written Opinion dated Feb. 7, 2017, by the ISA/US, re App No. PCT/US2013/054741, 10 pages.”
 “International Search Report and Written Opinion dated Jan. 23, 2015, by the ISA/EP, re App No. PCT/US2013/055257, 15 pages.”
 International Search Report and Written Opinion for Application No. PCT/US2009/068822 dated Aug. 9, 2010, 7 pages.
 International Search Report and Written Opinion for Application No. PCT/US2010/031738 dated Dec. 27, 2010, 7 pages.
 International Search Report and Written Opinion for Application No. PCT/US2010/037156 dated Jan. 13, 2011, 8 pages.
 International Search Report and Written Opinion for Application No. PCT/US2010/039834 dated Feb. 8, 2011, 6 pages.
 International Search Report and Written Opinion for Application No. PCT/US2012/050376 dated Oct. 26, 2012, 10 pages.
 “International Search Report for Application No. PCT/US2016/37391, by ISA/US, dated Sep. 9, 2016, 2 pages.”
 “Notice of Allowance dated Apr. 10, 2015, by the USPTO, re U.S. Appl. No. 29/493,861, 8 pages.”
 “Notice of Allowance dated Apr. 9, 2015, by the USPTO, re U.S. Appl. No. 13/965,848, 8 pages.”
 “Notice of Allowance dated Aug. 29, 2005, by the USPTO, re U.S. Appl. No. 10/690,888, 7 pages.”
 “Notice of Allowance dated Dec. 17, 2015, by the USPTO, re U.S. Appl. No. 13/886,771, 13 pages.”
 “Notice of Allowance dated Dec. 26, 2014, by the USPTO, re U.S. Appl. No. 13/918,479, 10 pages.”
 “Notice of Allowance dated Feb. 11, 2009, by the USPTO, re U.S. Appl. No. 11/414,984, 8 pages.”
 “Notice of Allowance dated Feb. 12, 2007, by the USPTO, re U.S. Appl. No. 11/013,486, 4 pages.”
 “Notice of Allowance dated Feb. 19, 2013, by the USPTO, re U.S. Appl. No. 12/793,194, 10 pages.”
 “Notice of Allowance dated Feb. 7, 2014, by the USPTO, re U.S. Appl. No. 29/449,852, 31 pages.”
 “Notice of Allowance dated Feb. 7, 2014, by the USPTO, re U.S. Appl. No. 29/449,867, 31 pages.”
 “Notice of Allowance dated Jan. 16, 2014, by the USPTO, re U.S. Appl. No. 29/453,837, dated 39 pages.”
 “Notice of Allowance dated Jul. 6, 2005, by the USPTO, re U.S. Appl. No. 10/833,859, 4 pages.”
 “Notice of Allowance dated Jun. 25, 2014, by the USPTO, re U.S. Appl. No. 12/165,680, 12 pages.”
 “Notice of Allowance dated Jun. 29, 2010, by the USPTO, re U.S. Appl. No. 11/354,663, 5 pages.”
 “Notice of Allowance dated May 16, 2012, by the USPTO, re U.S. Appl. No. 12/763,786, 6 pages.”
 “Notice of Allowance dated Nov. 22, 2013, by the USPTO, re U.S. Appl. No. 12/822,900, 10 pages.”
 “Notice of Allowance dated Nov. 26, 2013, by the USPTO, re U.S. Appl. No. 29/429,809, 11 pages.”

* cited by examiner

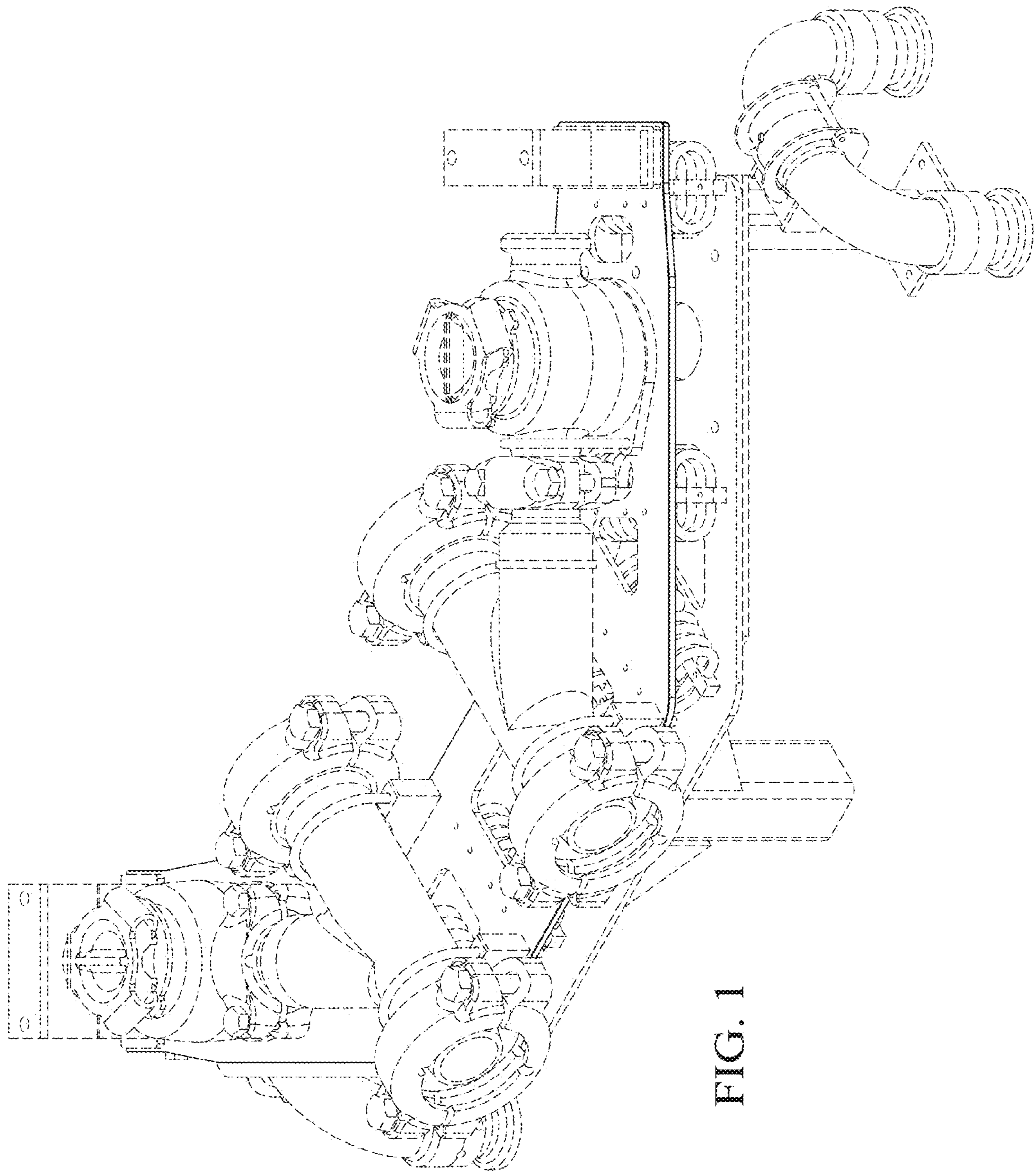

FIG. 1

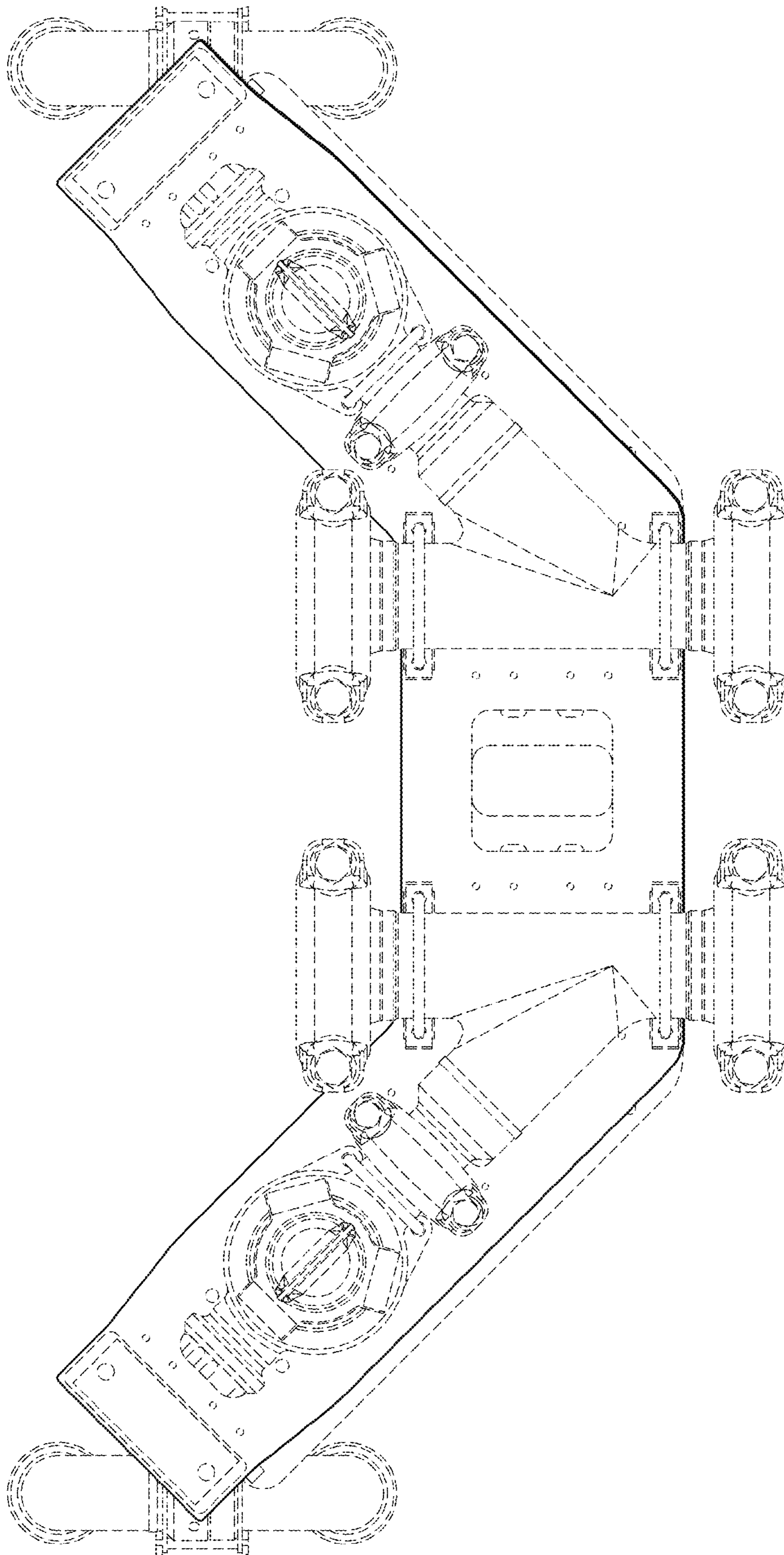

FIG. 2

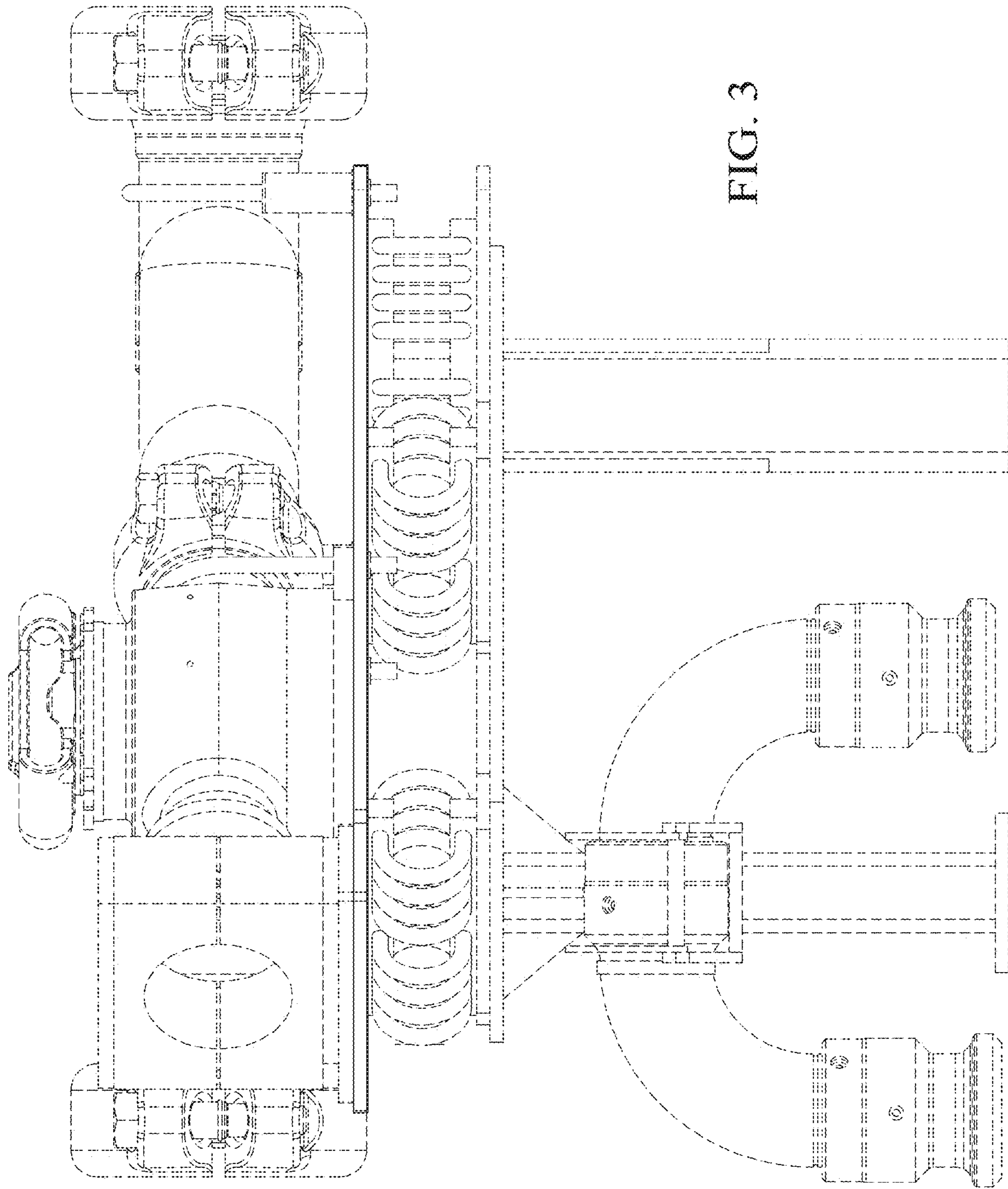

FIG. 3

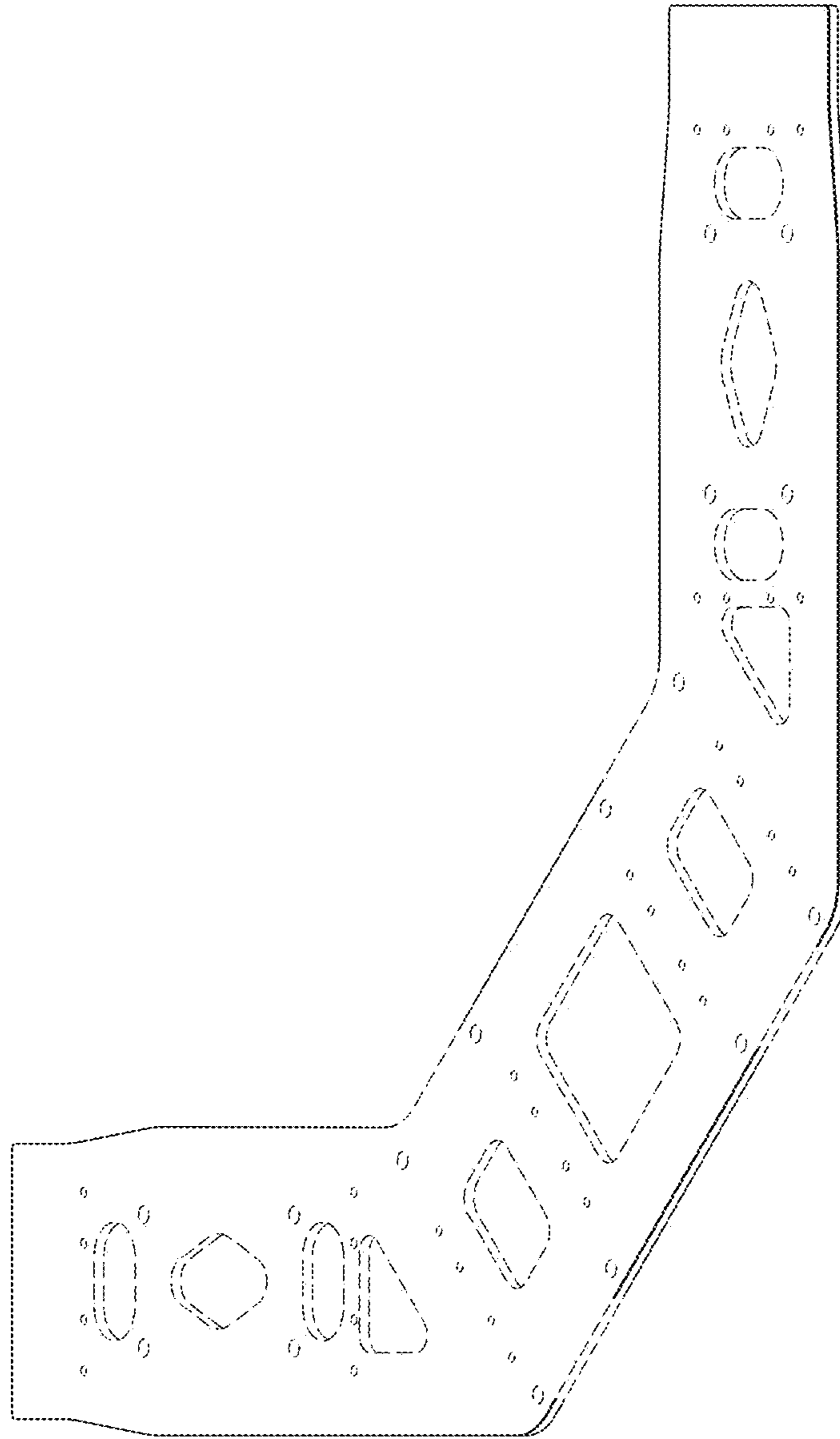

FIG. 4

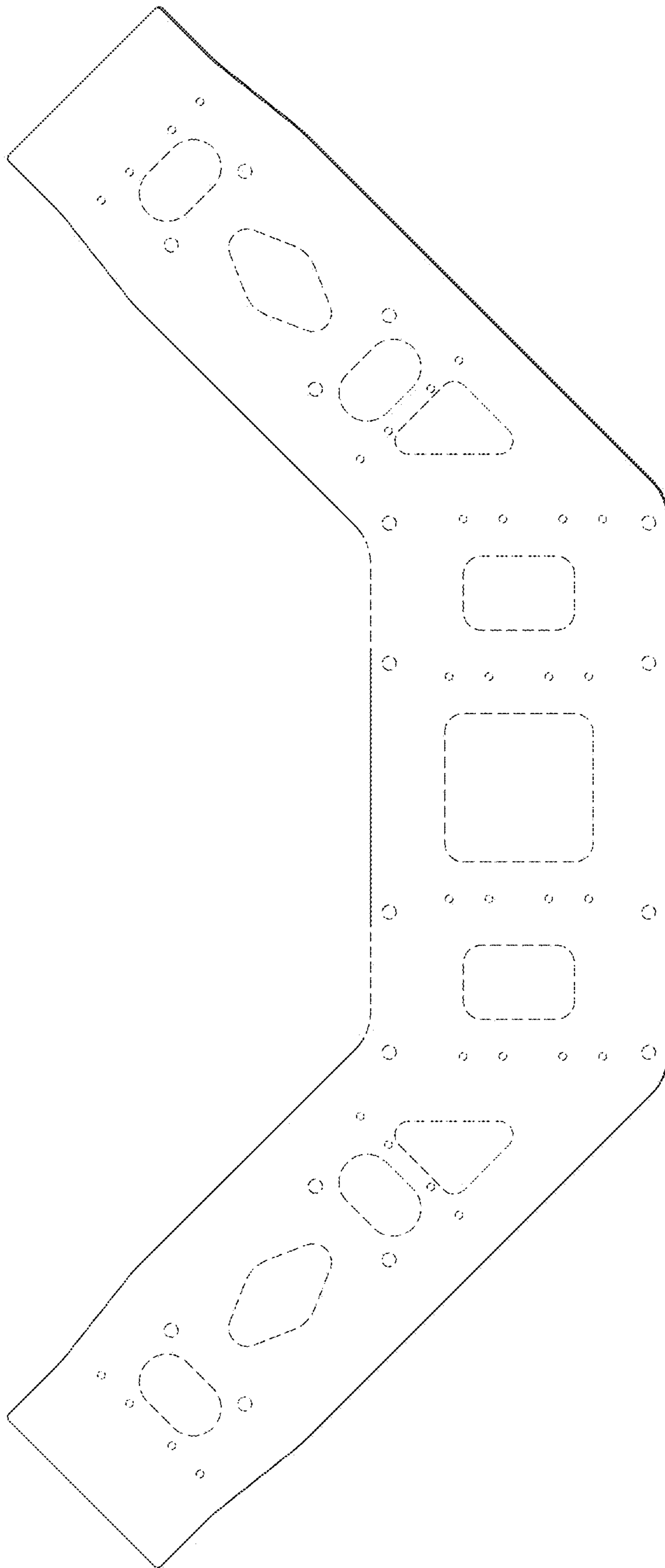

FIG. 5

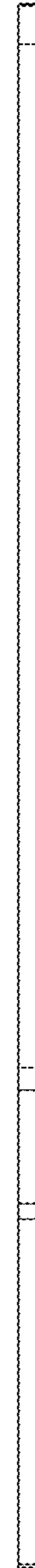

FIG. 6