



US00D873759S

(12) **United States Design Patent**  
**Viklund**

(10) **Patent No.:** **US D873,759 S**  
(45) **Date of Patent:** **\*\* Jan. 28, 2020**

- (54) **BIKE CRADLE**
- (71) Applicant: **Thule Sweden AB**, Hillerstorp (SE)
- (72) Inventor: **Mark Viklund**, New Milford, CT (US)
- (73) Assignee: **Thule Sweden AB**, Hillerstorp (SE)
- (\*\*) Term: **15 Years**
- (21) Appl. No.: **29/656,591**
- (22) Filed: **Jul. 13, 2018**
- (51) **LOC (12) Cl.** ..... **12-16**
- (52) **U.S. Cl.**  
USPC ..... **D12/408**
- (58) **Field of Classification Search**  
USPC .... D12/406-408, 414, 414.1, 412, 400, 402,  
D12/115, 223; D8/349, 356  
CPC .. B60R 9/06; B60R 9/10; B60R 9/045; B60R  
9/048  
See application file for complete search history.

- D659,631 S \* 5/2012 Laverack ..... D12/408
- D707,617 S \* 6/2014 Flaherty ..... D12/407
- D821,289 S \* 6/2018 Bjornstad ..... D12/407
- D852,114 S \* 6/2019 Anderson ..... D12/407
- 2001/0025866 A1 10/2001 Morris et al.
- 2007/0034657 A1\* 2/2007 Murray ..... B60R 9/06  
224/497

(Continued)

*Primary Examiner* — Michelle E. Wilson  
*Assistant Examiner* — Clese Moore, Jr.  
(74) *Attorney, Agent, or Firm* — Sterne, Kessler,  
Goldstein & Fox P.L.L.C.

(57) **CLAIM**

The ornamental design for a bike cradle, as shown and described.

**DESCRIPTION**

FIG. 1 is a top front perspective view of a bike cradle showing the claimed design;  
FIG. 2 is a bottom front perspective view thereof;  
FIG. 3 is a front view thereof;  
FIG. 4 is a rear view thereof;  
FIG. 5 is a left side view thereof;  
FIG. 6 is a right side view thereof;  
FIG. 7 is a top view thereof;  
FIG. 8 is a bottom view thereof;  
FIG. 9 is a top front perspective view of the bike cradle shown in an alternate configuration;  
FIG. 10 is a bottom front perspective view thereof;  
FIG. 11 is a front view thereof;  
FIG. 12 is a rear view thereof;  
FIG. 13 is a left side view thereof;  
FIG. 14 is a right side view thereof;  
FIG. 15 is a top view thereof; and,  
FIG. 16 is a bottom view thereof.  
The broken lines shown illustrate portions of the bike cradle that form no part of the claimed design.

(56) **References Cited**

U.S. PATENT DOCUMENTS

5,259,542	A	11/1993	Newbold et al.	
6,286,738	B1 *	9/2001	Robins .....	B60R 9/06 224/314
6,616,023	B1	9/2003	Dahl et al.	
6,988,645	B1 *	1/2006	Nusbaum .....	B60R 9/048 224/324
7,213,731	B1 *	5/2007	Kolda .....	B60R 9/048 224/42.39
D612,320	S *	3/2010	Flaherty .....	D12/408
D614,562	S *	4/2010	Flaherty .....	D12/408
D624,004	S *	9/2010	Farber .....	D12/408
D625,247	S *	10/2010	Flaherty .....	D12/408
D634,258	S *	3/2011	Farber .....	D12/408
D634,697	S *	3/2011	Weaver .....	D12/408
D637,137	S *	5/2011	Weaver .....	D12/408
D647,452	S *	10/2011	Laverack .....	D12/408
D656,080	S *	3/2012	Budd .....	D12/408
D656,456	S *	3/2012	Tinstman .....	D12/408

**1 Claim, 16 Drawing Sheets**

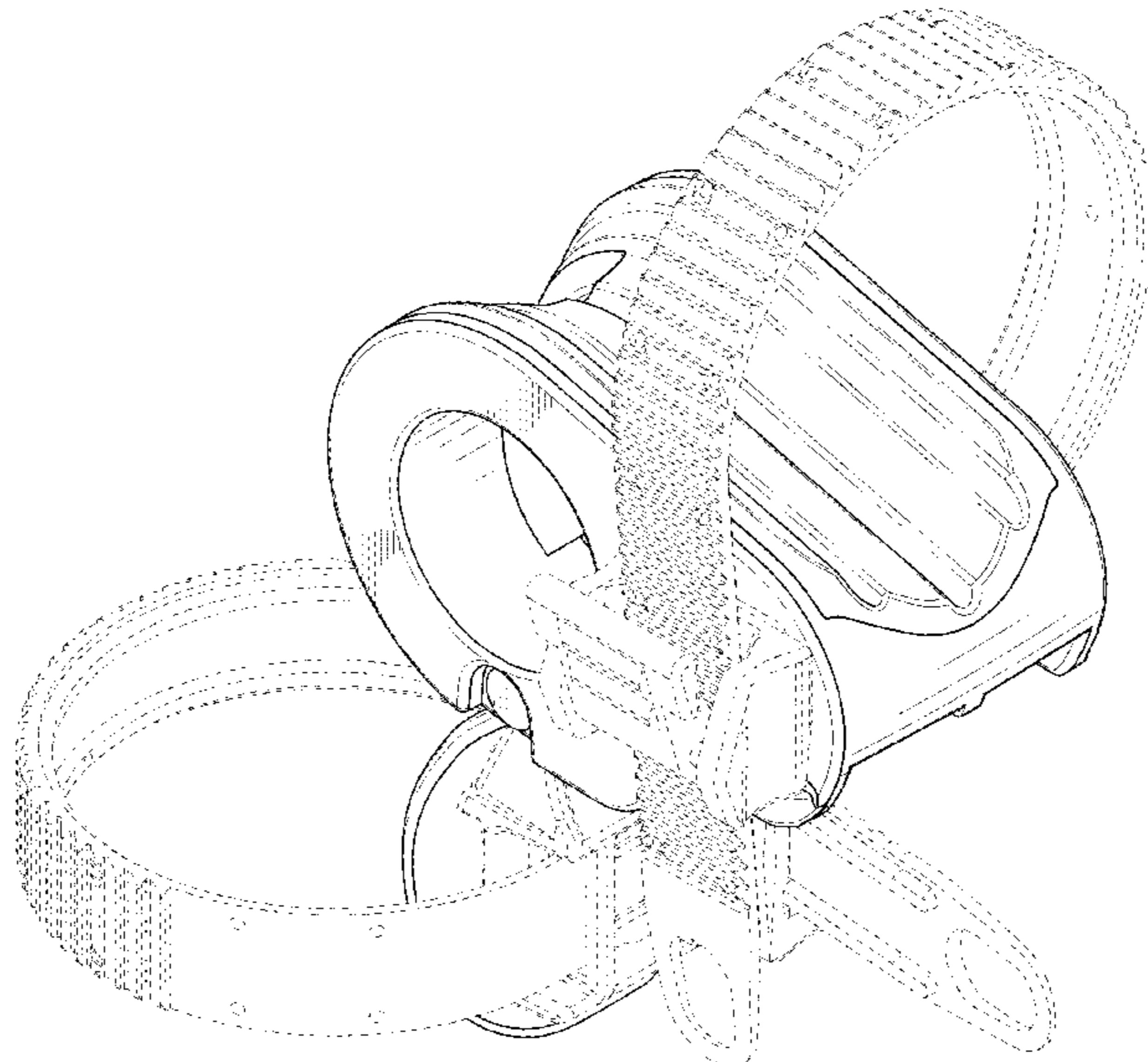

(56)

**References Cited**

U.S. PATENT DOCUMENTS

2007/0057001 A1\* 3/2007 Wang ..... B60R 9/06  
224/536  
2008/0093404 A1 4/2008 Clausen et al.  
2009/0120985 A1 5/2009 Sautter et al.  
2010/0127031 A1 5/2010 Sautter et al.  
2011/0068138 A1\* 3/2011 Flaherty ..... B60R 9/06  
224/324  
2012/0205414 A1\* 8/2012 Bogoslofski ..... B60R 9/06  
224/534  
2012/0234883 A1 9/2012 Sautter et al.  
2013/0015615 A1\* 1/2013 Bogoslofski ..... B60R 9/10  
267/141.2  
2013/0243518 A1\* 9/2013 Wiedemann ..... F16B 7/044  
403/66  
2017/0369000 A1 12/2017 Pedrini

\* cited by examiner

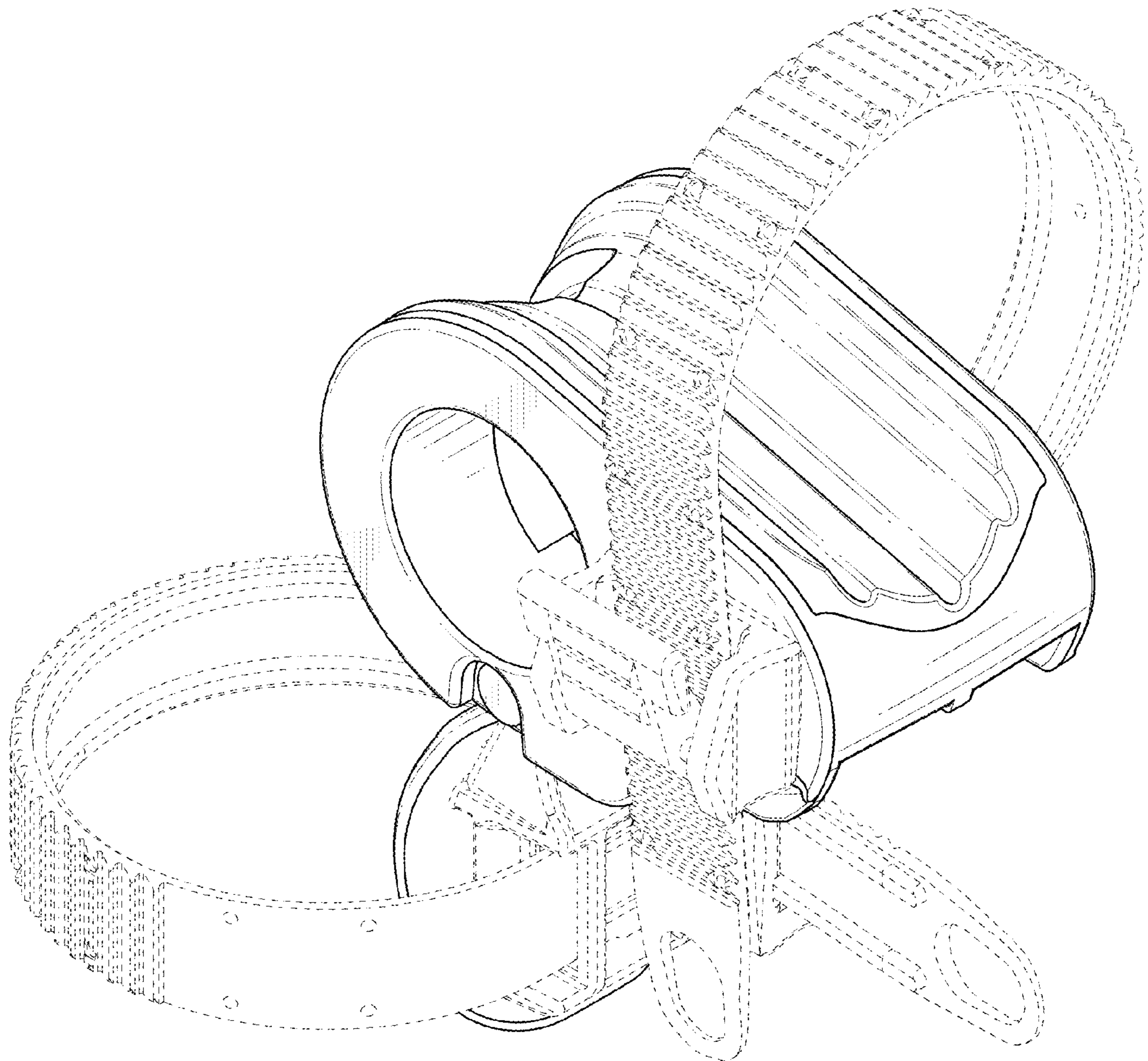

**FIG.1**

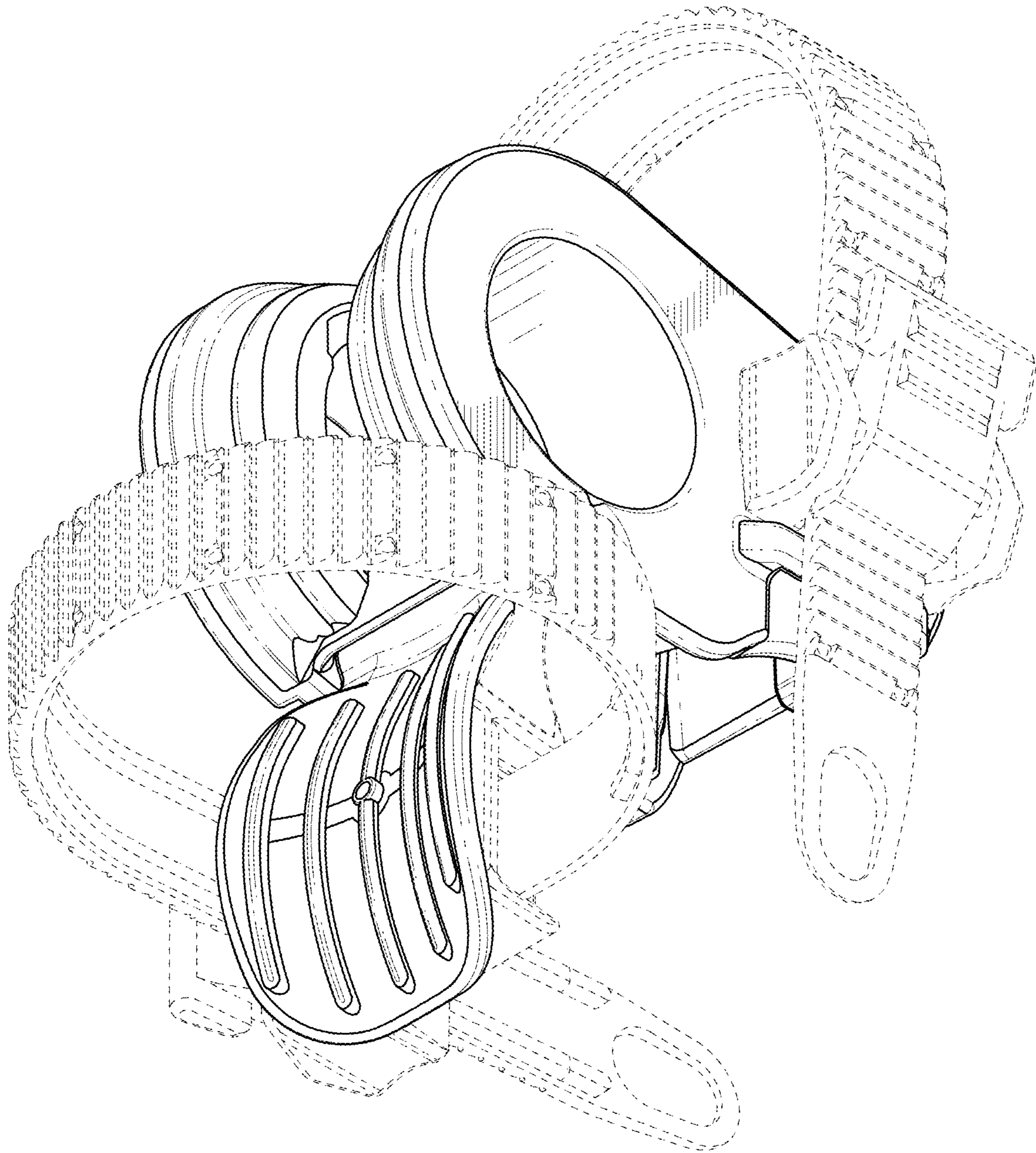

**FIG.2**

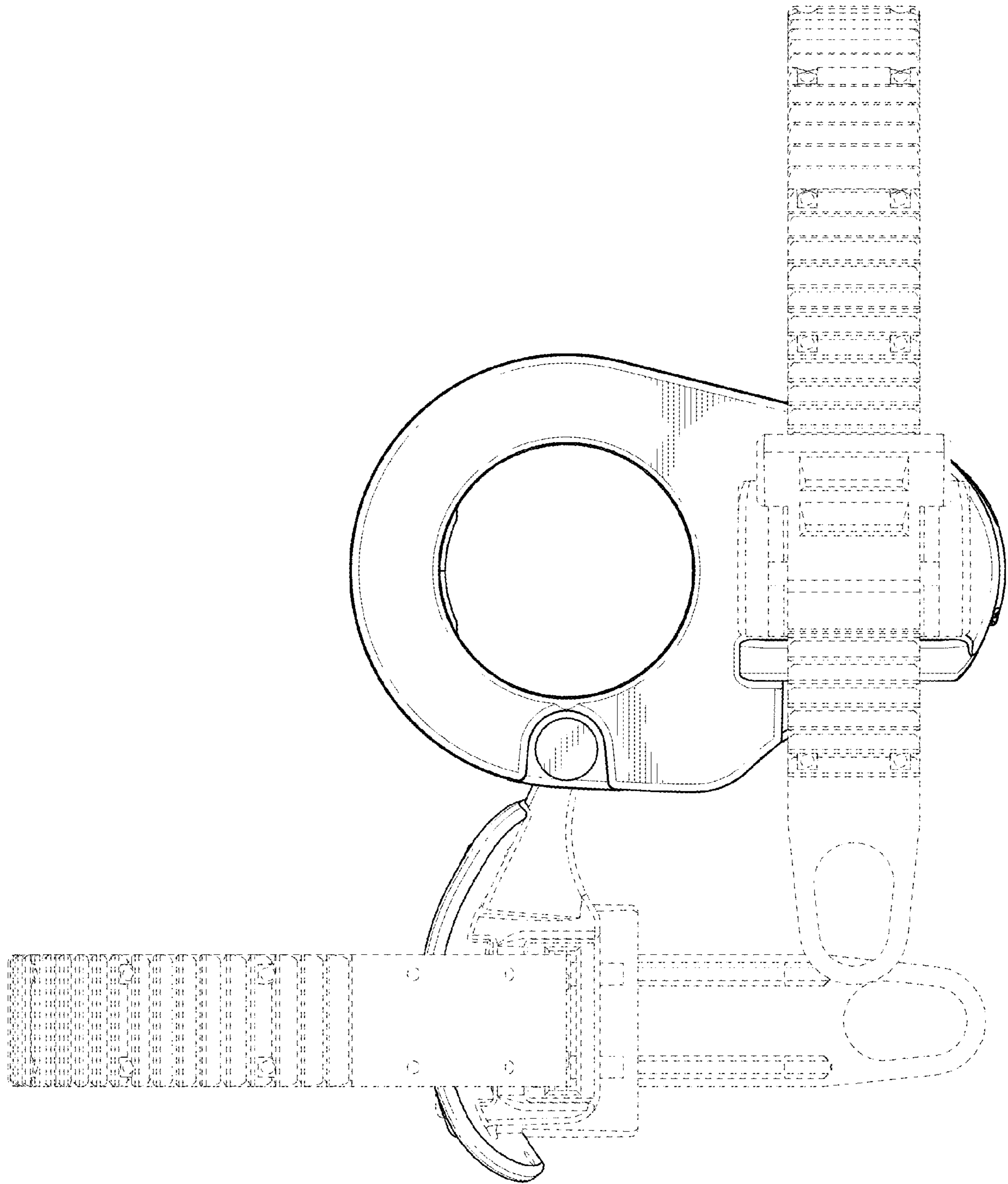

FIG.3

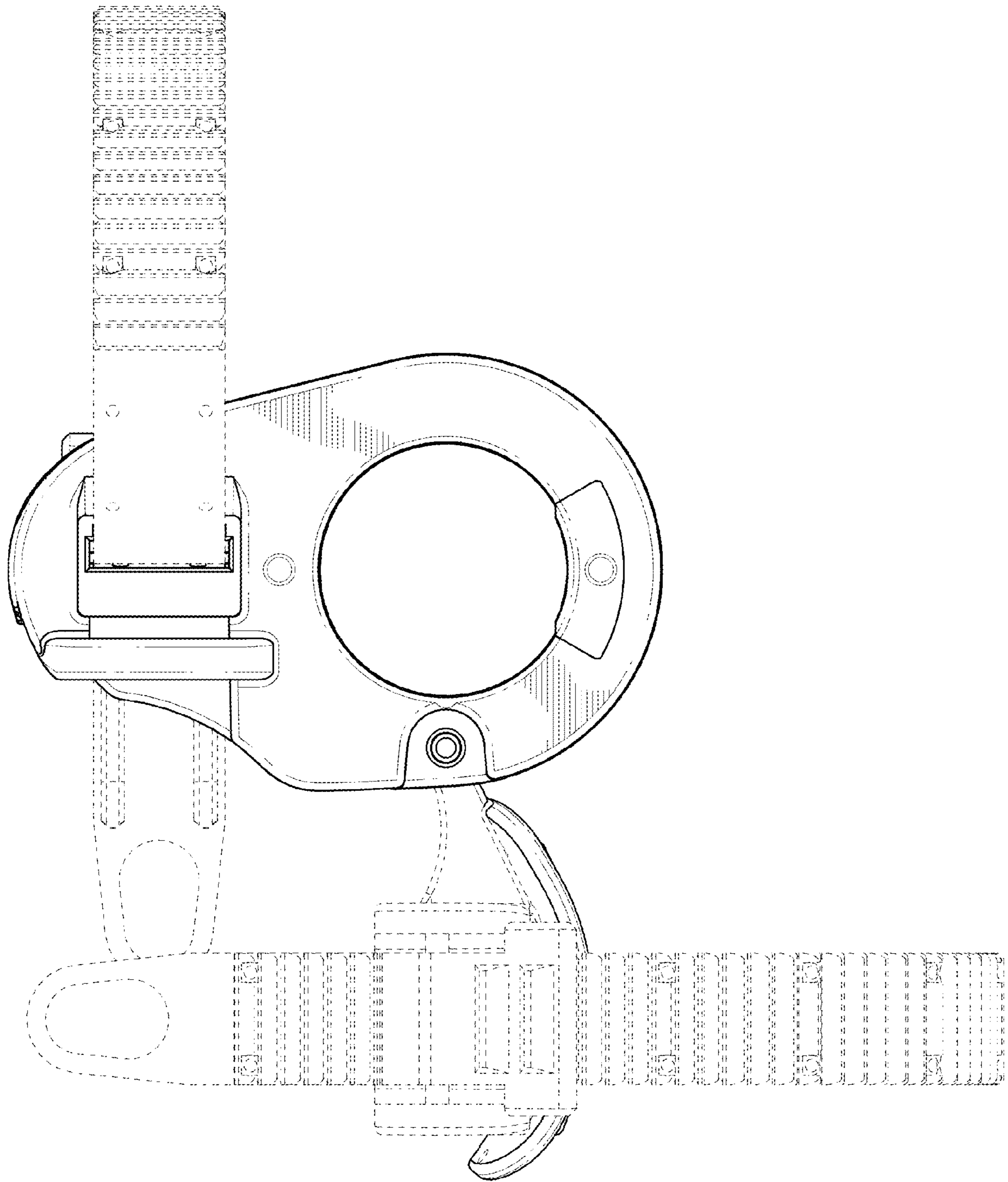

FIG.4

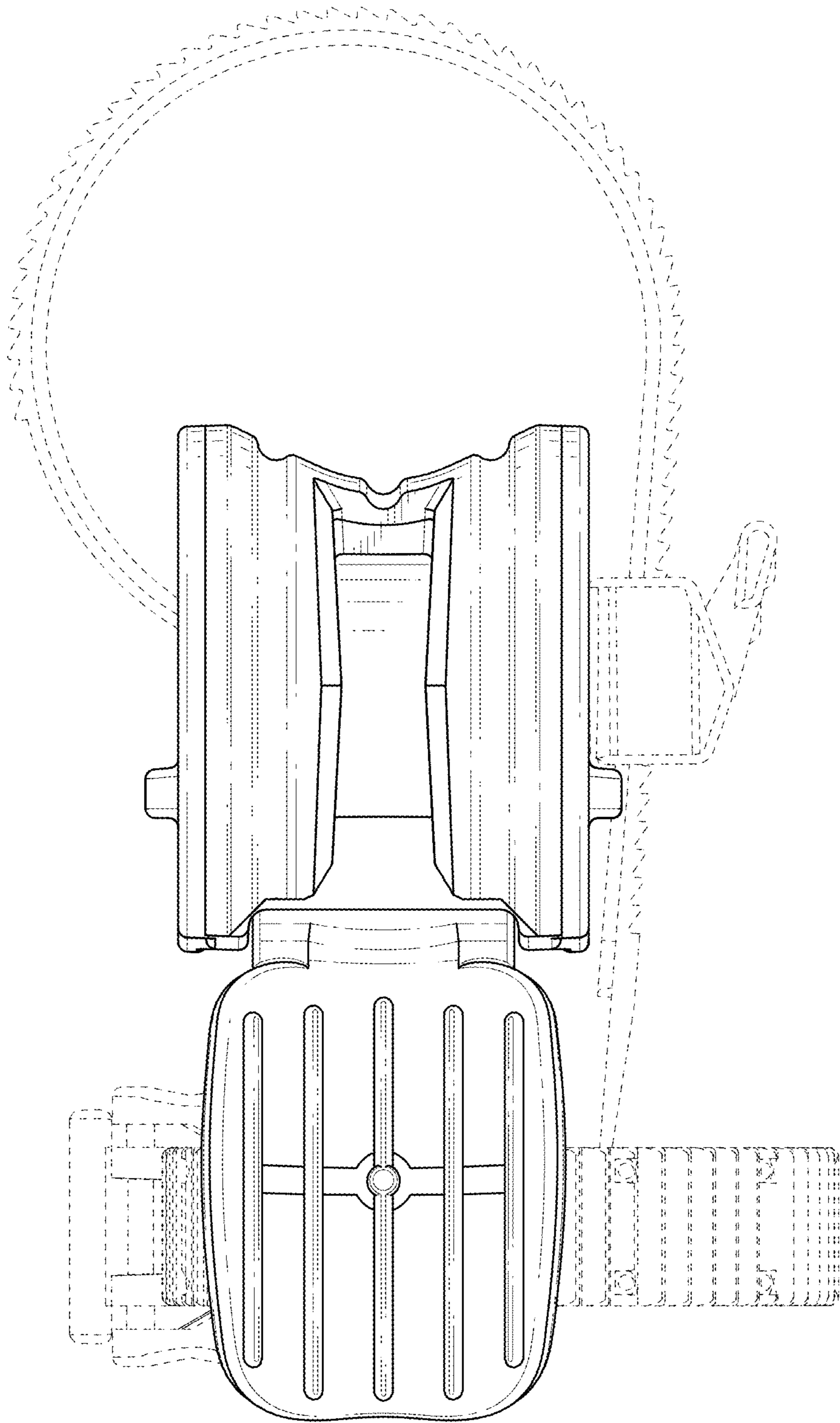

FIG.5

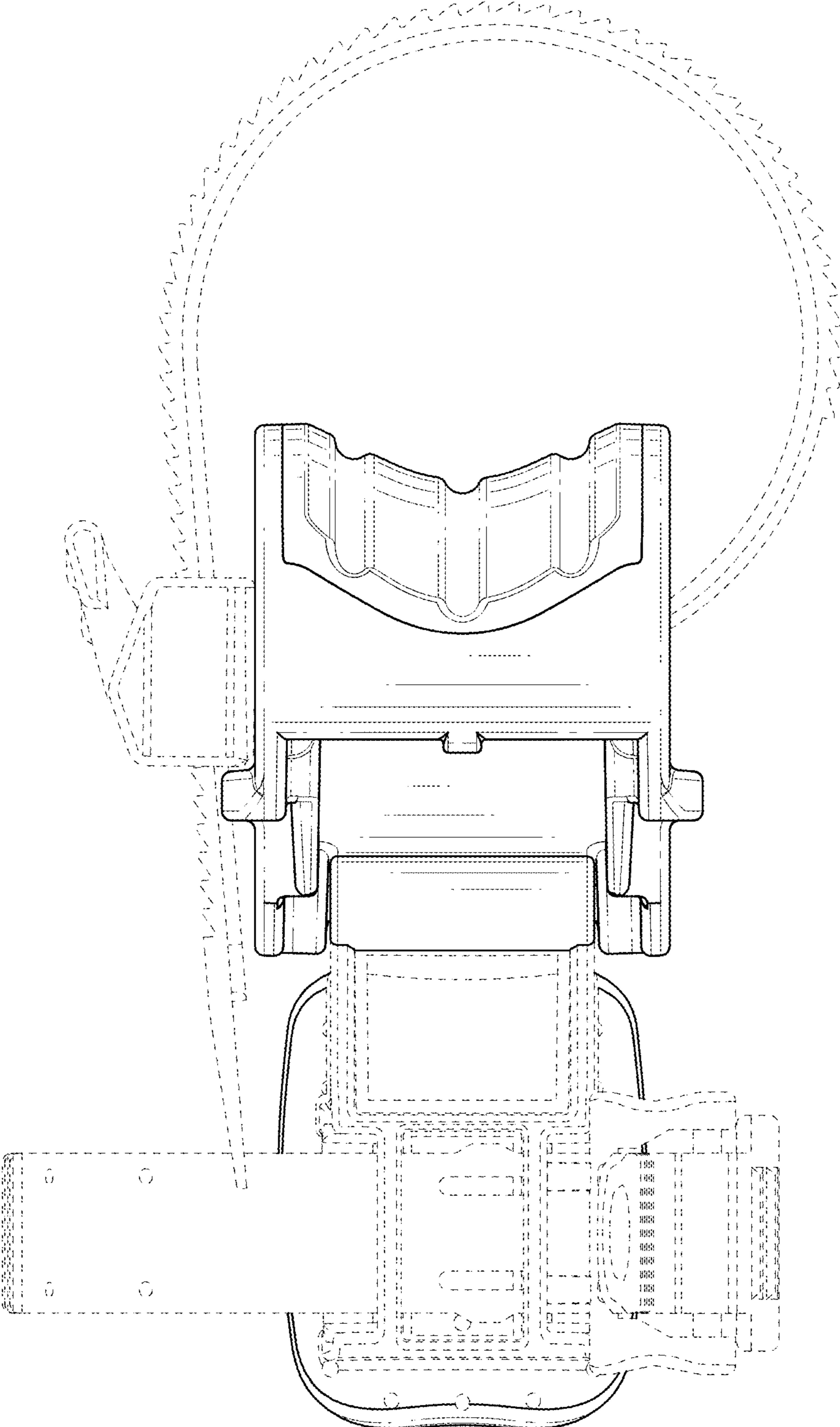

FIG. 6



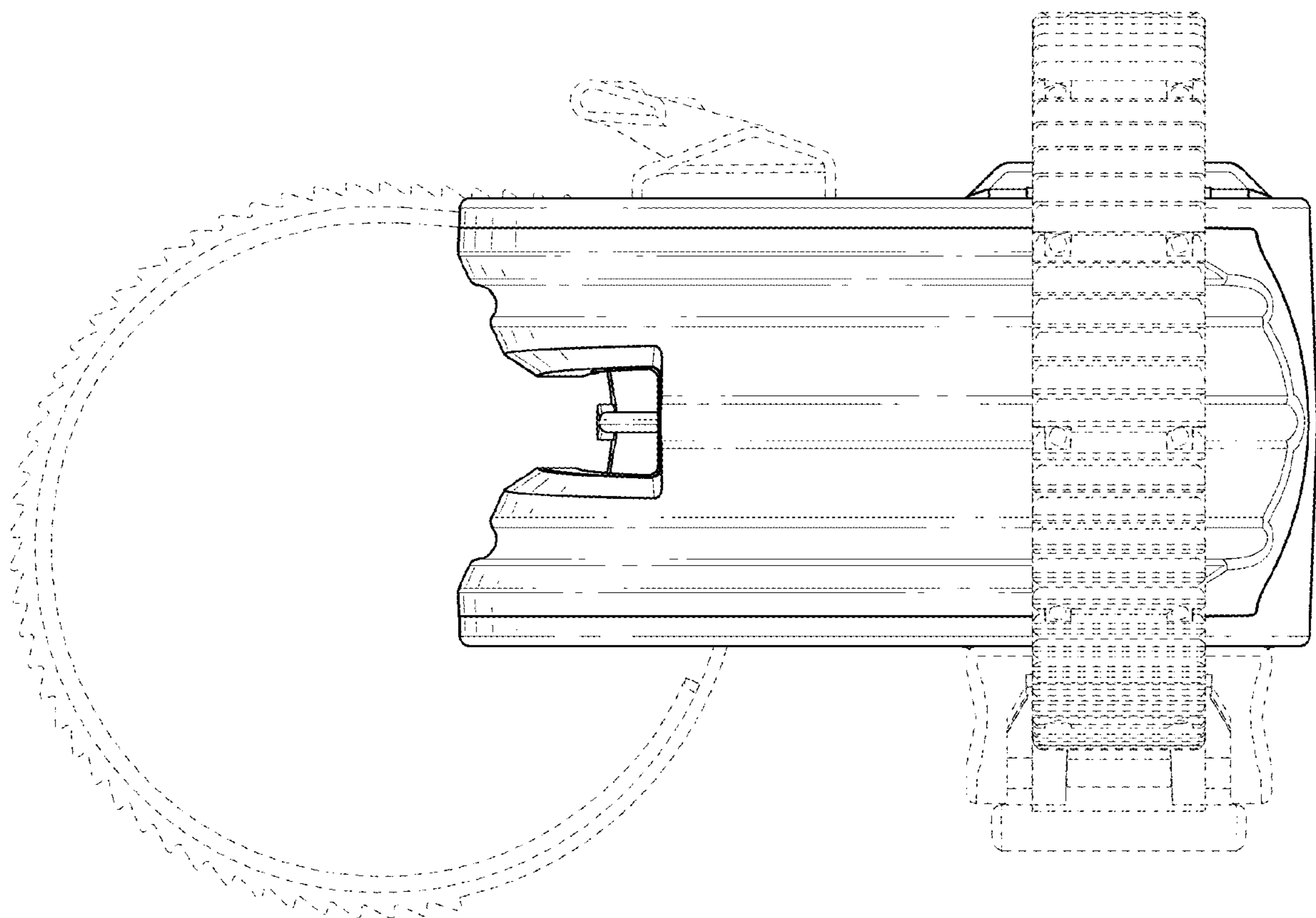

FIG.7

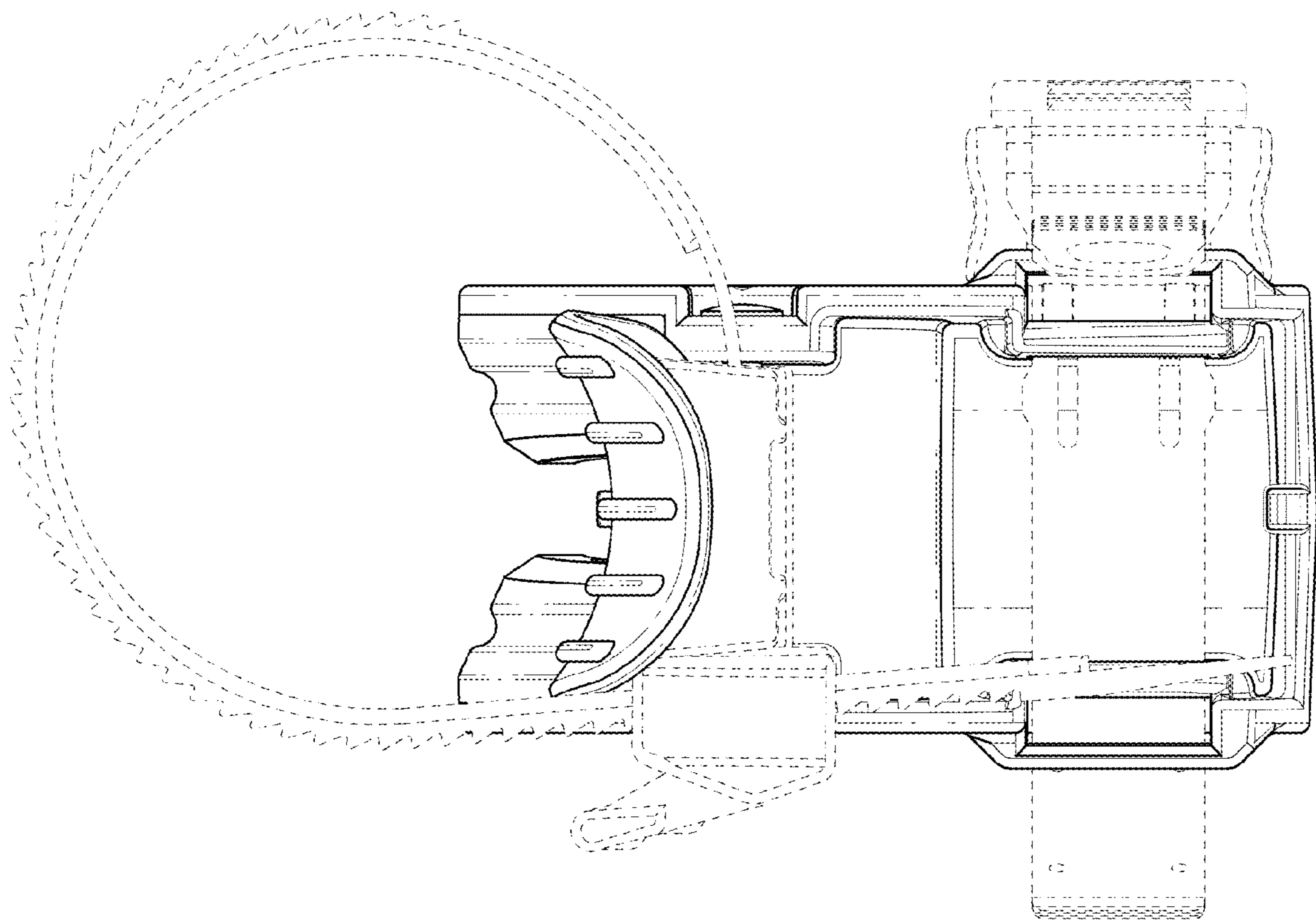
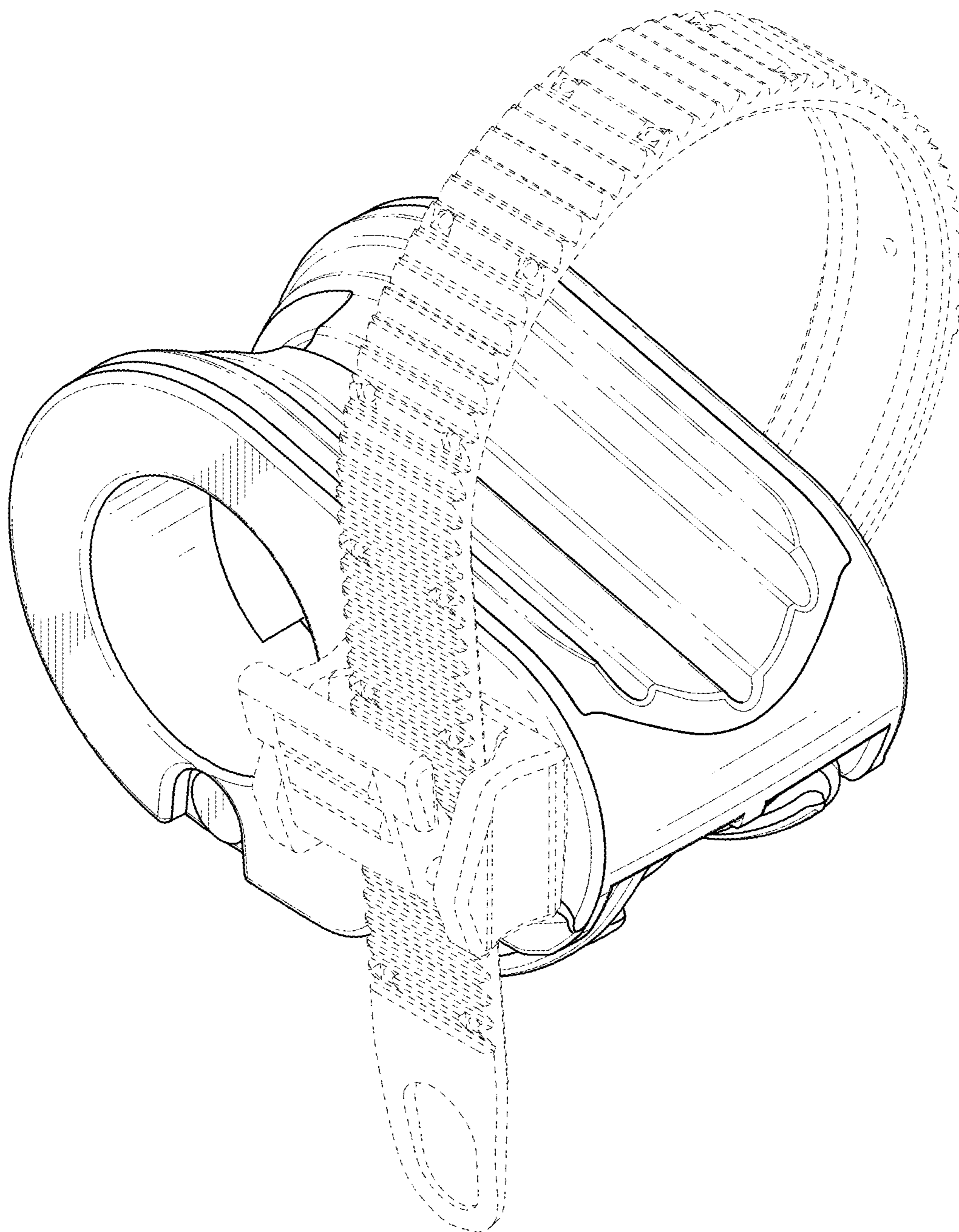

FIG. 8



**FIG. 9**

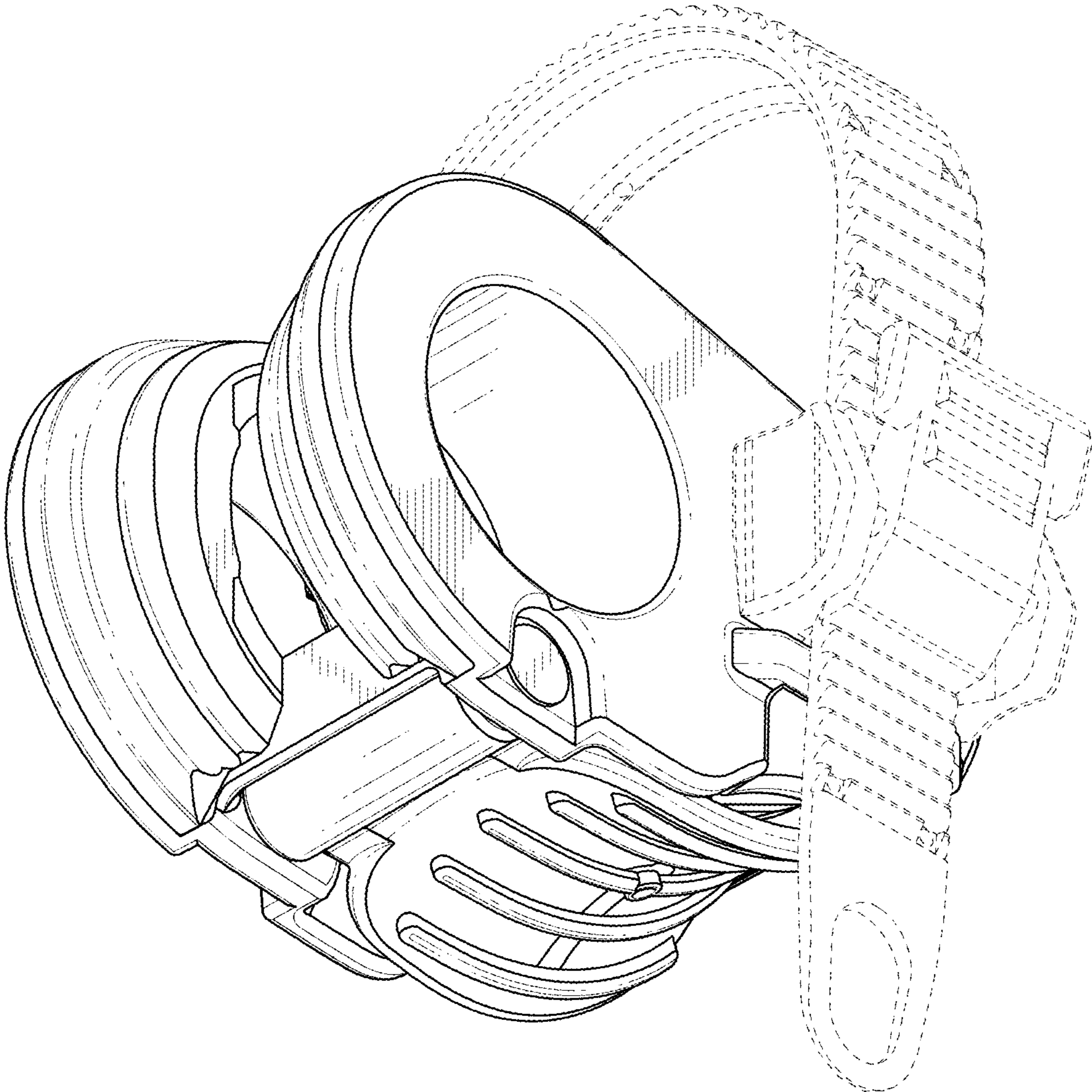
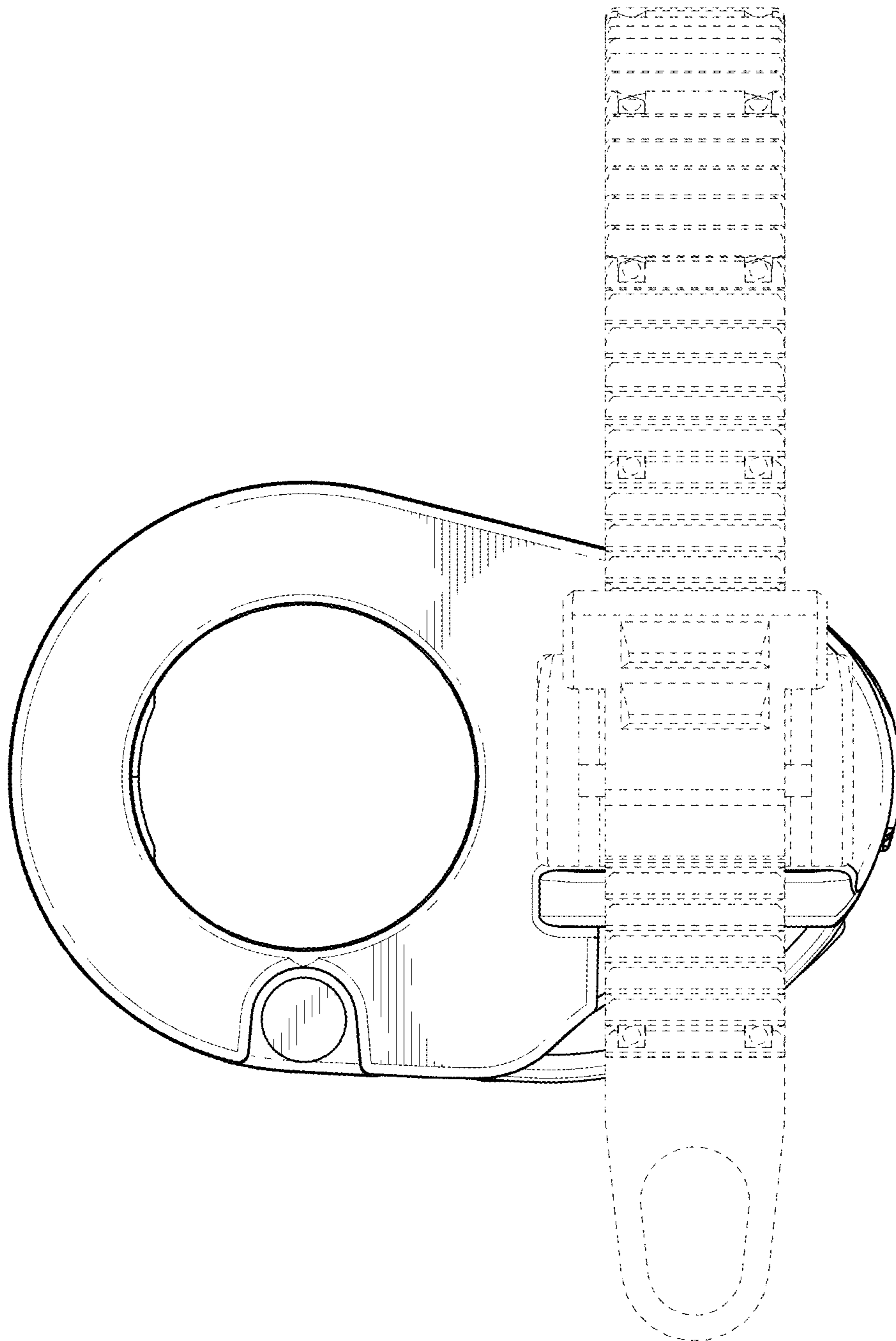

FIG.10



**FIG.11**

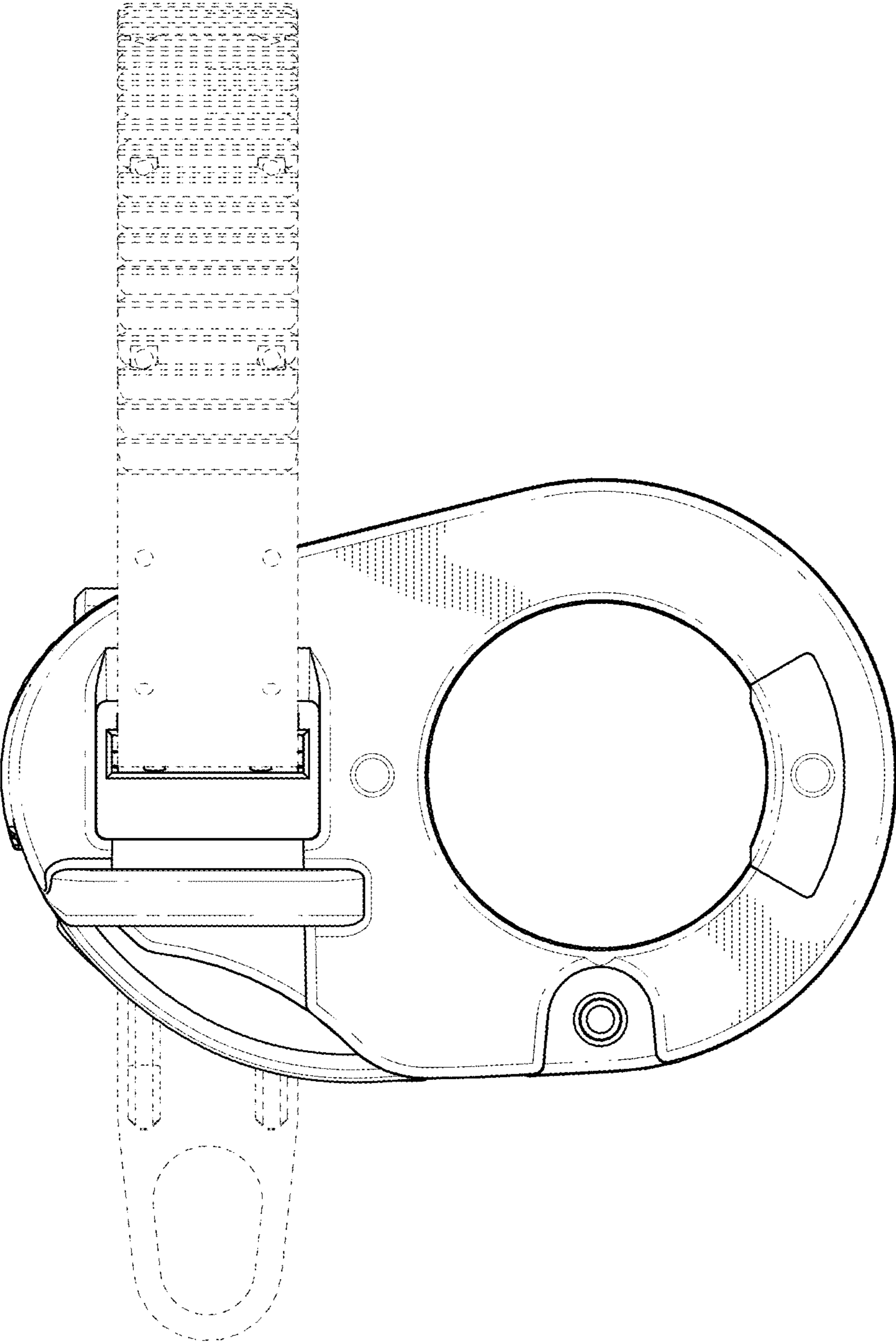
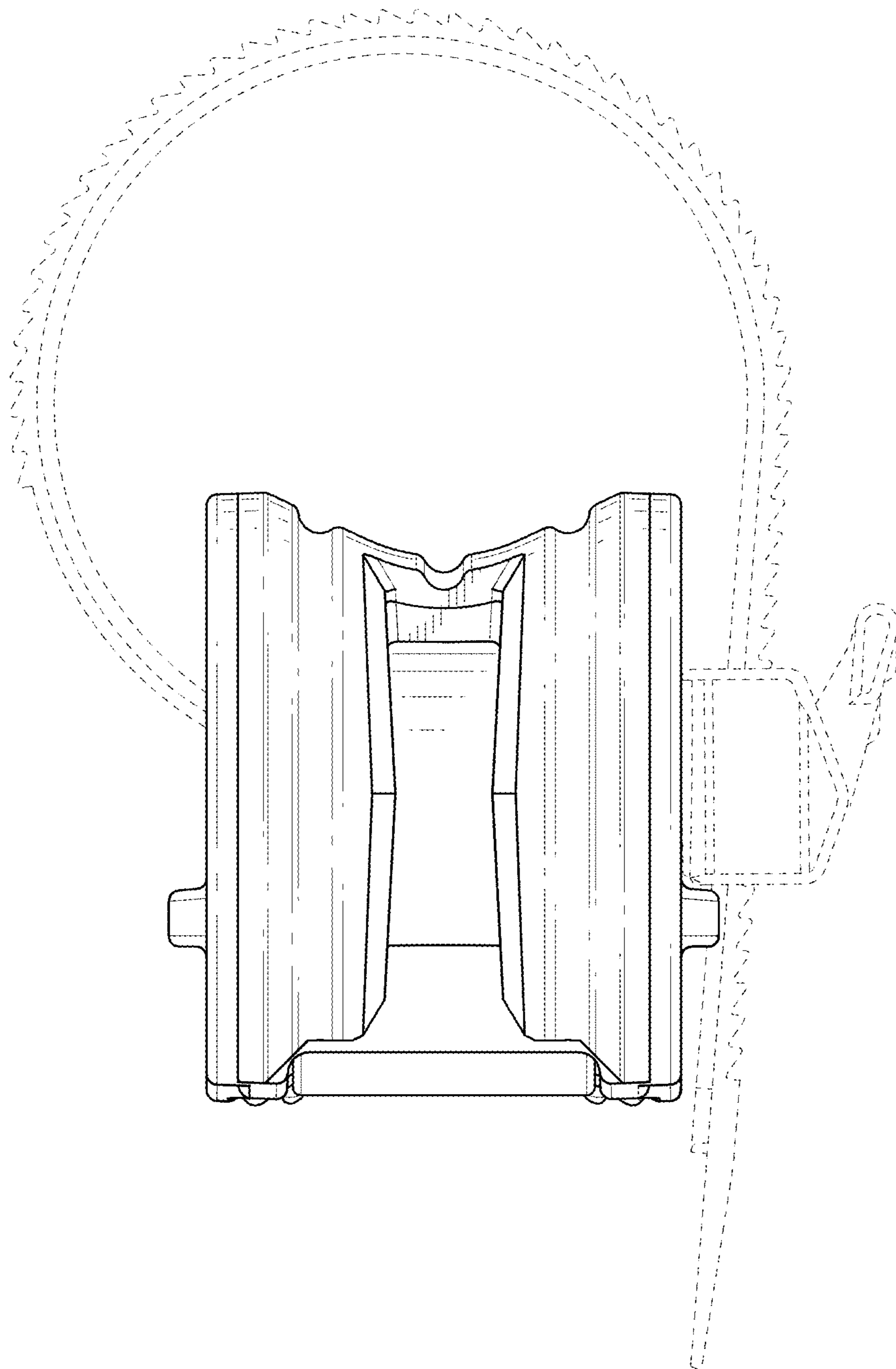
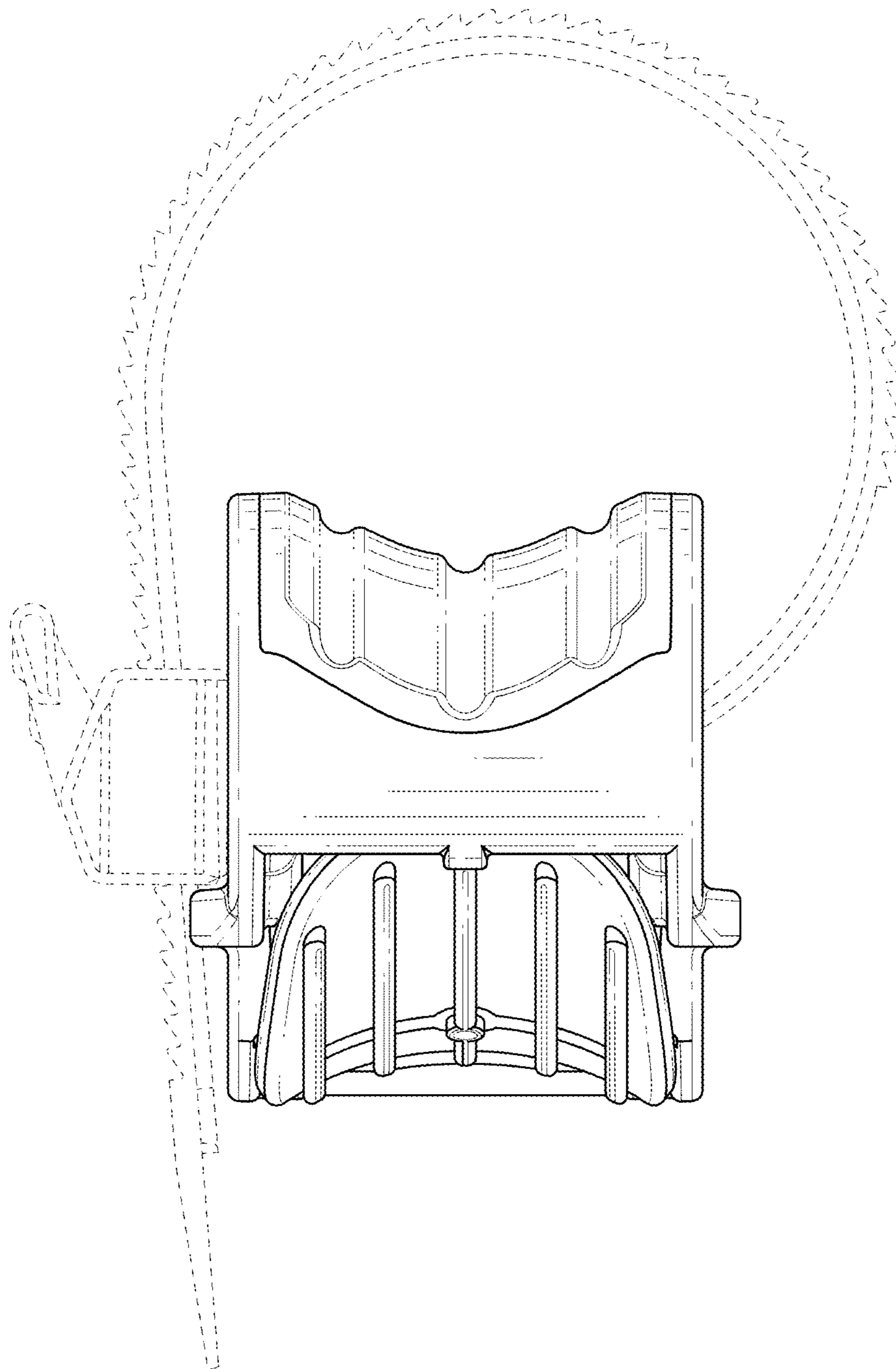

FIG.12



**FIG.13**



**FIG.14**



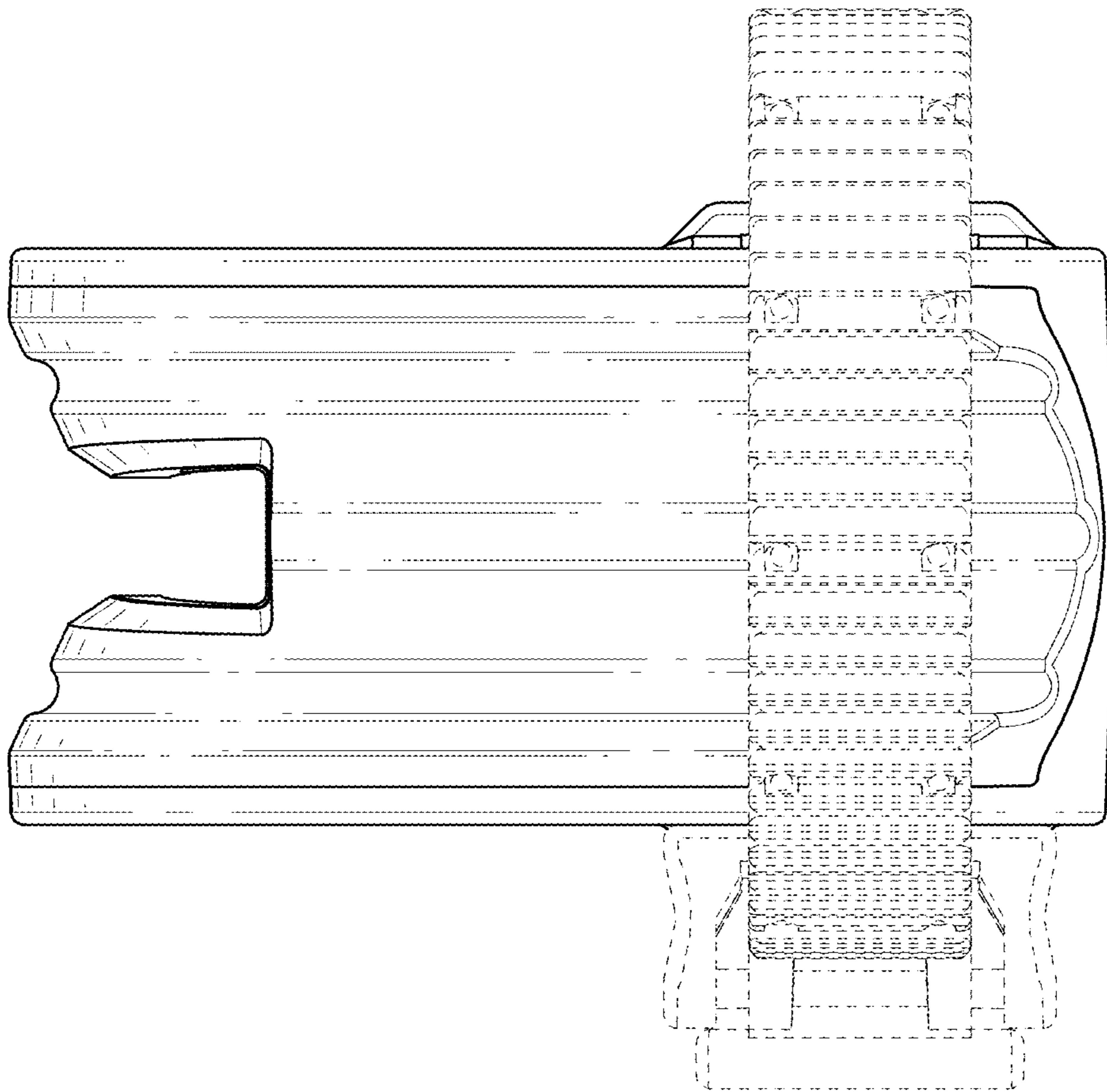
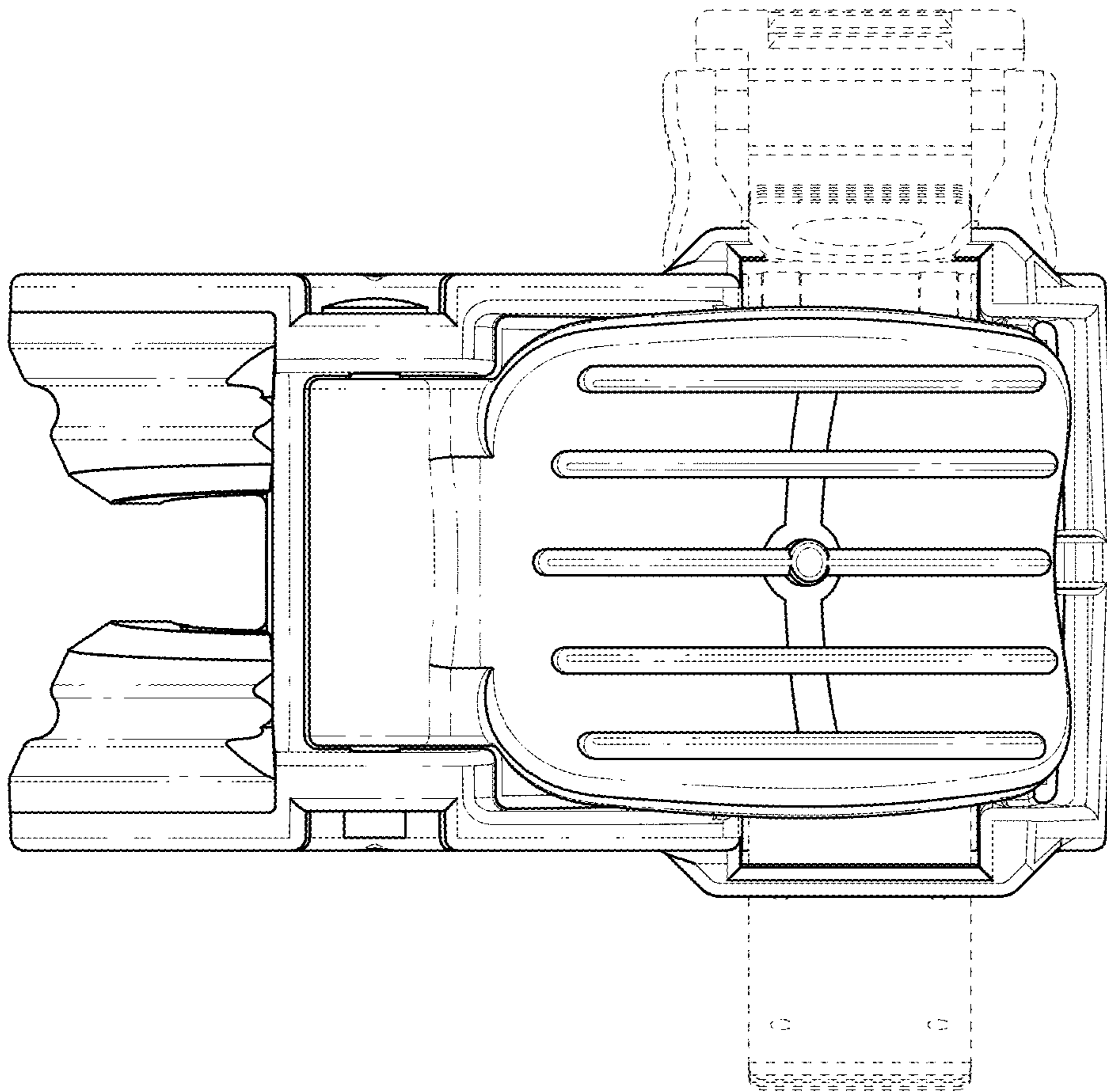

FIG.15



**FIG.16**