

US00D873712S

(12) **United States Design Patent**
Hall

(10) **Patent No.:** **US D873,712 S**
(45) **Date of Patent:** **** Jan. 28, 2020**

- (54) **REVERSE TRIKE ROADSTER**
- (71) Applicant: **Stephen R. Hall**, Draper, UT (US)
- (72) Inventor: **Stephen R. Hall**, Draper, UT (US)
- (73) Assignee: **Hall Labs LLC**, Provo, UT (US)
- (**) Term: **15 Years**
- (21) Appl. No.: **29/628,772**
- (22) Filed: **Dec. 7, 2017**
- (51) **LOC (12) Cl.** **12-08**
- (52) **U.S. Cl.**
USPC **D12/85**
- (58) **Field of Classification Search**
USPC D12/85, 86, 107, 131; D21/424, 433,
D21/434
CPC B62D 21/11; B62D 29/043; B62D 31/00;
B62D 49/00; B62D 61/065; B62L 3/00;
B62K 3/005; B62K 5/01; B62K 5/08;
B62K 5/027
See application file for complete search history.

D592,548 S * 5/2009 Aube D12/85
D613,203 S * 4/2010 Geslin D12/85
D626,032 S * 10/2010 Starr D12/85

(Continued)

Primary Examiner — Darlington Ly

(57) **CLAIM**

The ornamental design for a reverse trike roadster, as shown and described.

DESCRIPTION

FIG. 1 is a front and left-side perspective view of a reverse trike roadster showing my new design.
FIG. 2 is a front and right-side perspective view thereof;
FIG. 3 is a rear and left-side perspective view thereof;
FIG. 4 is a rear and right-side perspective view thereof;
FIG. 5 is a bottom, front, and left-side perspective view thereof;
FIG. 6 is a bottom, front, and right-side perspective view thereof;
FIG. 7 is a bottom, rear, and left-side perspective view thereof;
FIG. 8 is a bottom, rear, and right-side perspective view thereof;
FIG. 9 is a front elevation view thereof;
FIG. 10 is a right-side elevation view thereof;
FIG. 11 is a left-side elevation view thereof;
FIG. 12 is a top plan view thereof;
FIG. 13 is a rear elevation view thereof;
FIG. 14 is a bottom plan view thereof;
FIG. 15 is an enlarged and partial top, front, and left-side perspective view of the seats and surrounding structures of the roadster; and,
FIG. 16 is an enlarged and partial top, front, and left-side perspective view of the front fascia and surrounding structures of the roadster.
The broken lines in the drawings illustrate portions of the reverse trike roadster that form no part of the claimed design.

(56) **References Cited**
U.S. PATENT DOCUMENTS

- D260,871 S * 9/1981 Cargile D12/85
- 4,573,546 A * 3/1986 Irimajiri B62D 61/065
180/211
- 4,703,824 A * 11/1987 Irimajiri B62D 61/065
180/210
- D404,688 S * 1/1999 Hanagan D12/85
- 6,015,022 A * 1/2000 Thuliez B62D 21/04
180/210
- D424,979 S * 5/2000 Hanagan D12/85
- D427,548 S * 7/2000 Sacco D12/85
- D449,018 S * 10/2001 Musser D12/85
- D469,037 S * 1/2003 Hanagan D12/85
- D584,188 S * 1/2009 Jenkins D12/85
- D589,844 S * 4/2009 Aube D12/85
- D592,547 S * 5/2009 Riley D12/85

1 Claim, 16 Drawing Sheets

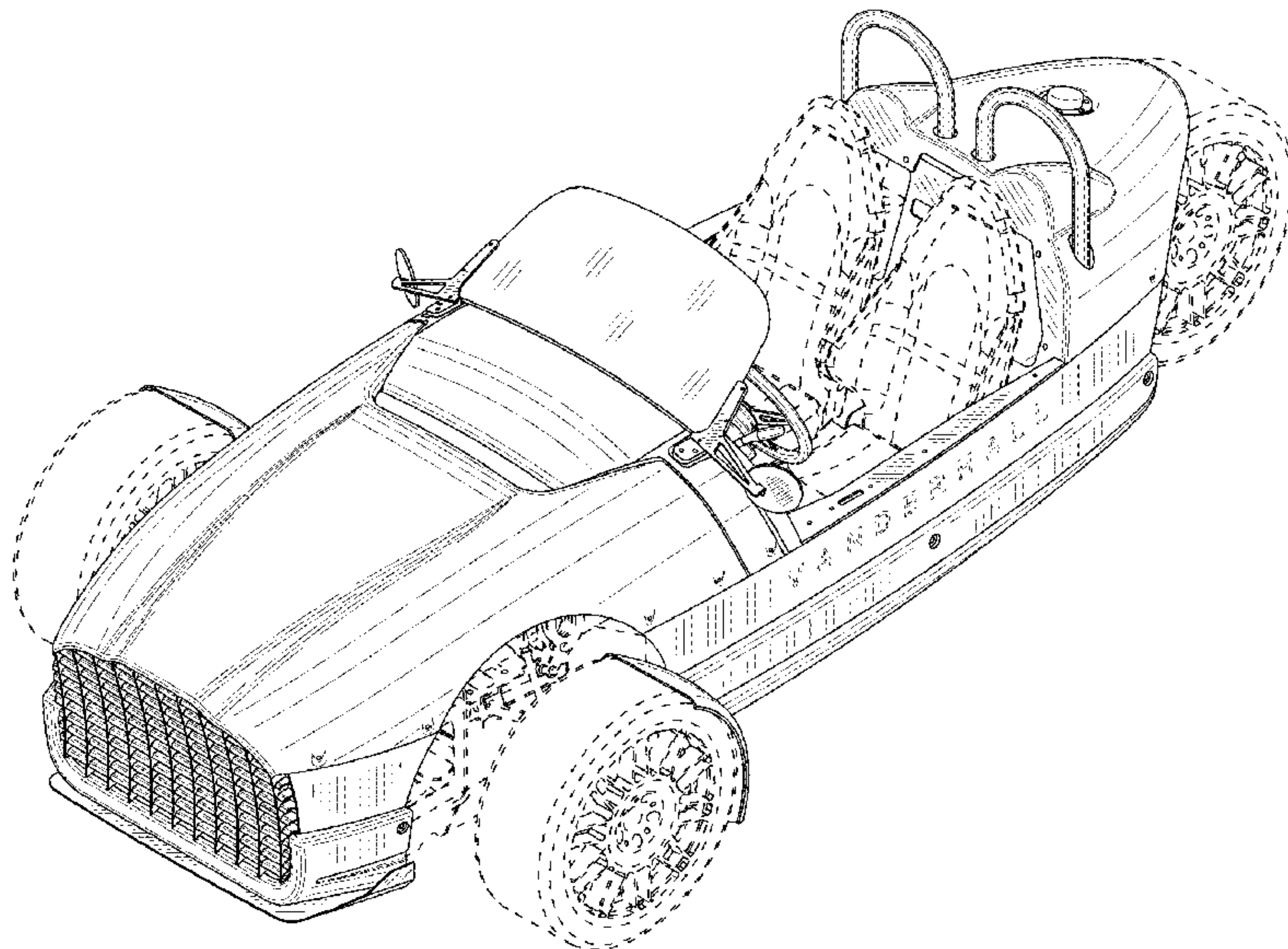

(56)

References Cited

U.S. PATENT DOCUMENTS

D633,821 S *	3/2011	Hill	D12/85
D666,127 S *	8/2012	Nam	D12/85
D678,124 S *	3/2013	Canni	D12/85
D682,158 S *	5/2013	Canni	D12/85
2012/0241239 A1 *	9/2012	Holroyd	B62K 5/05 180/210

* cited by examiner

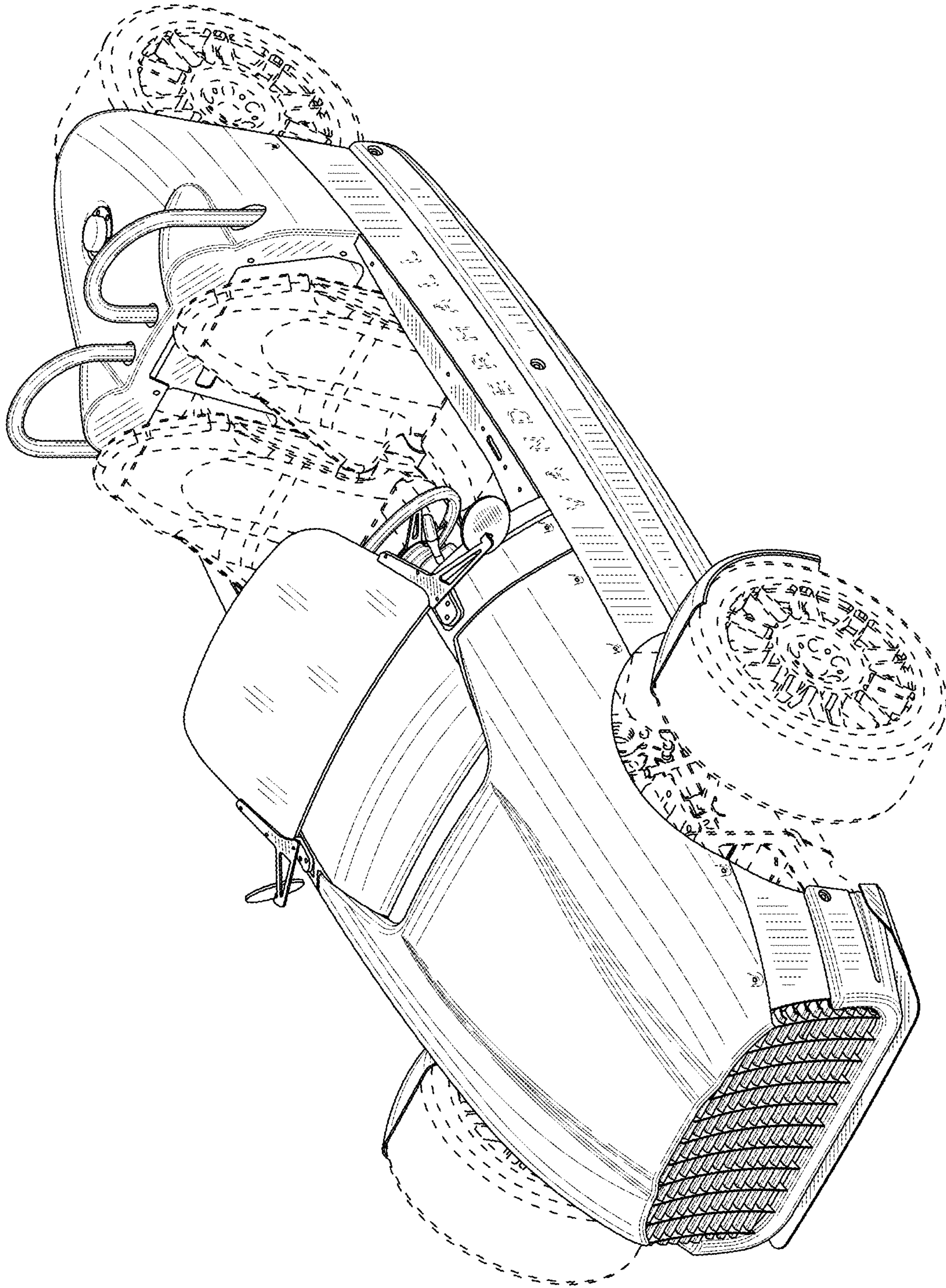

FIG. 1

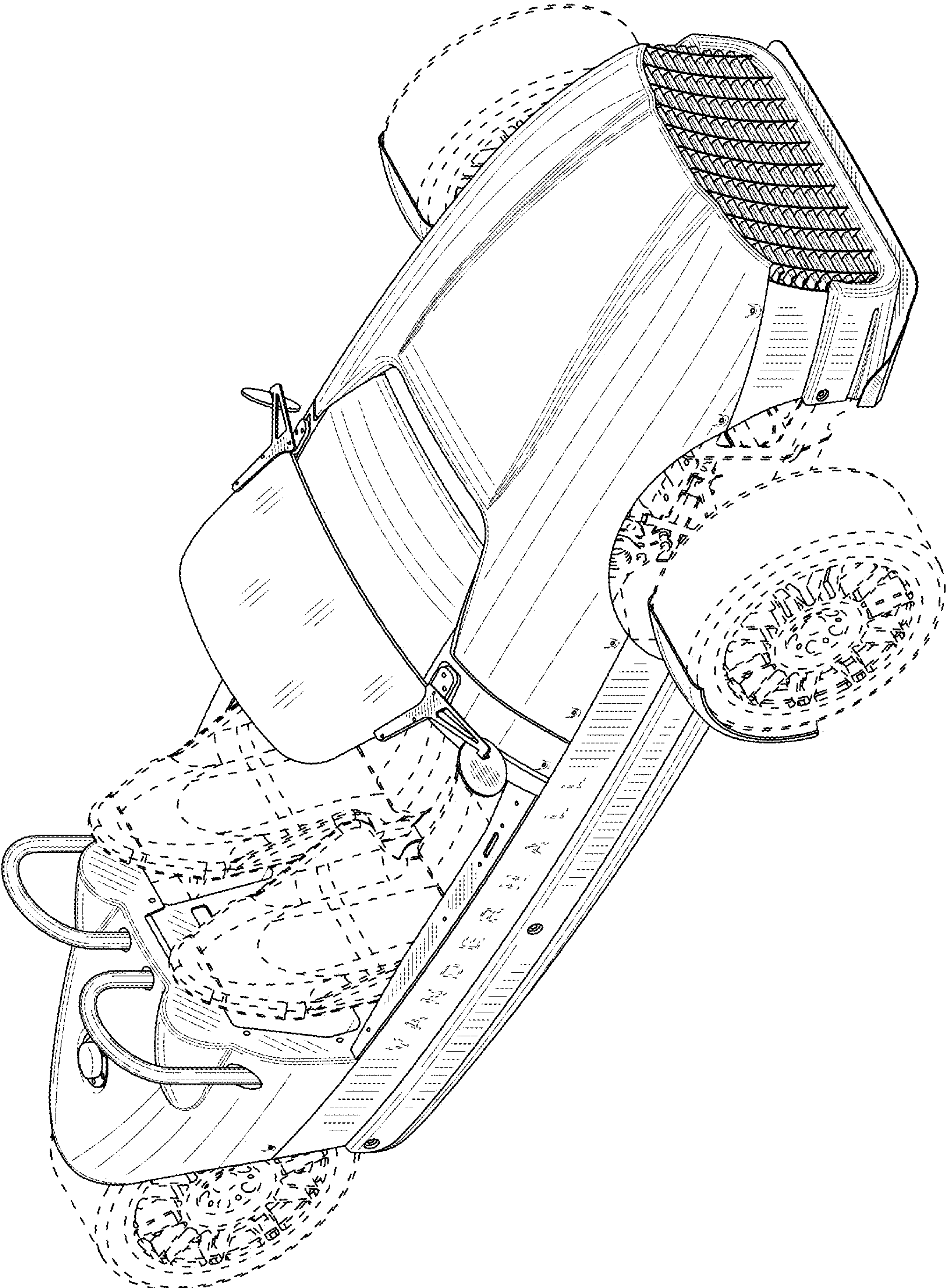

FIG. 2

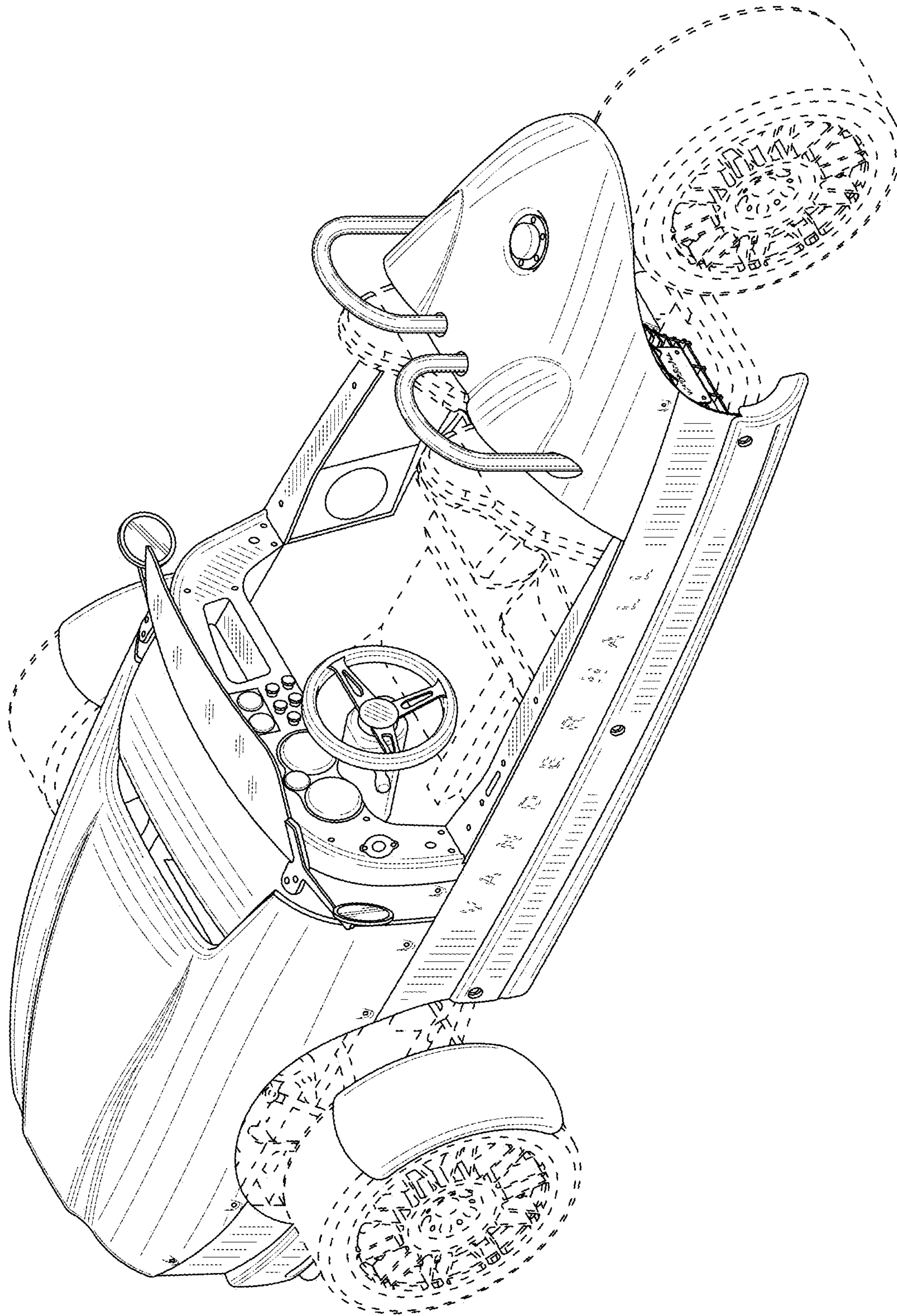

FIG. 3

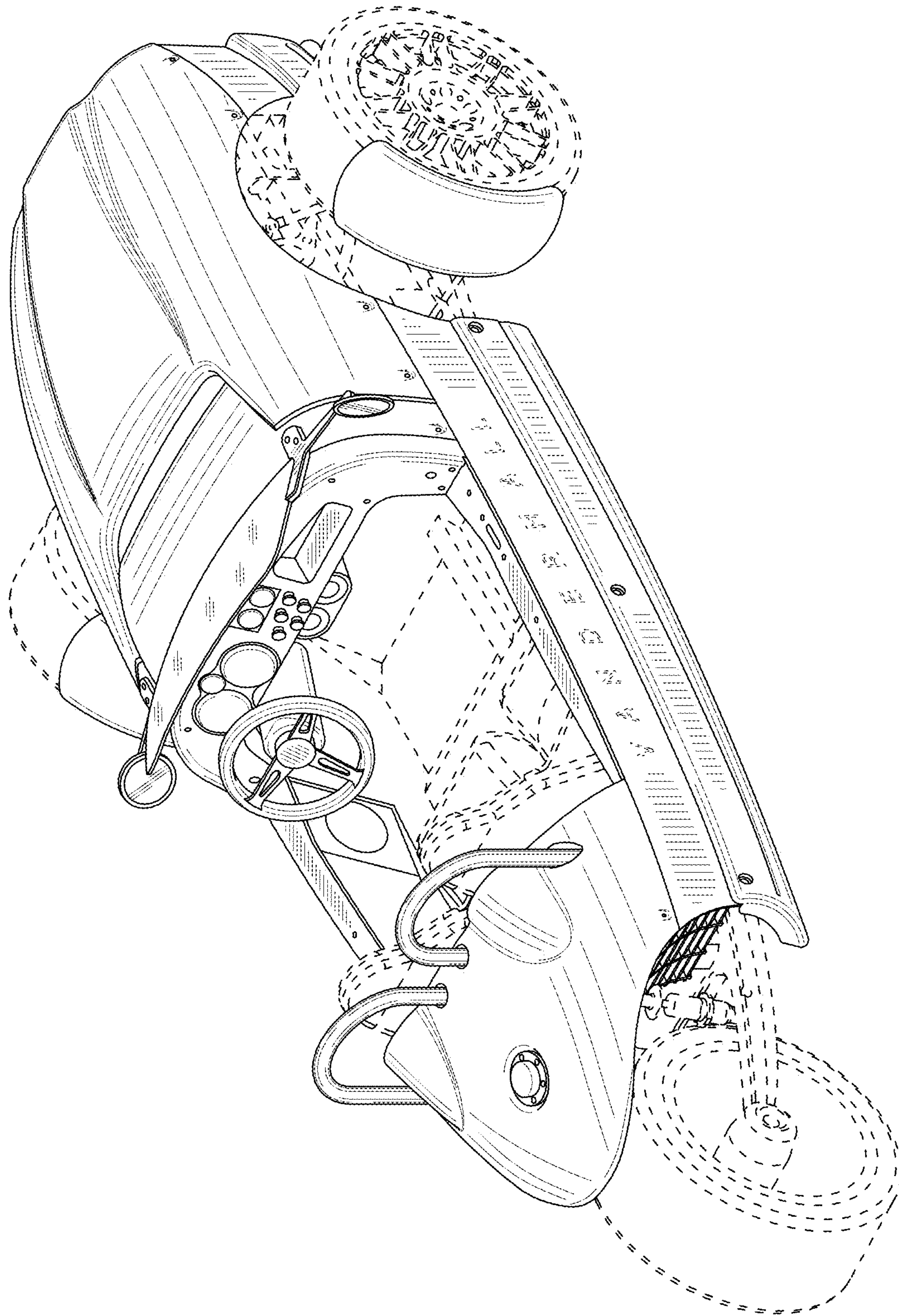

FIG. 4

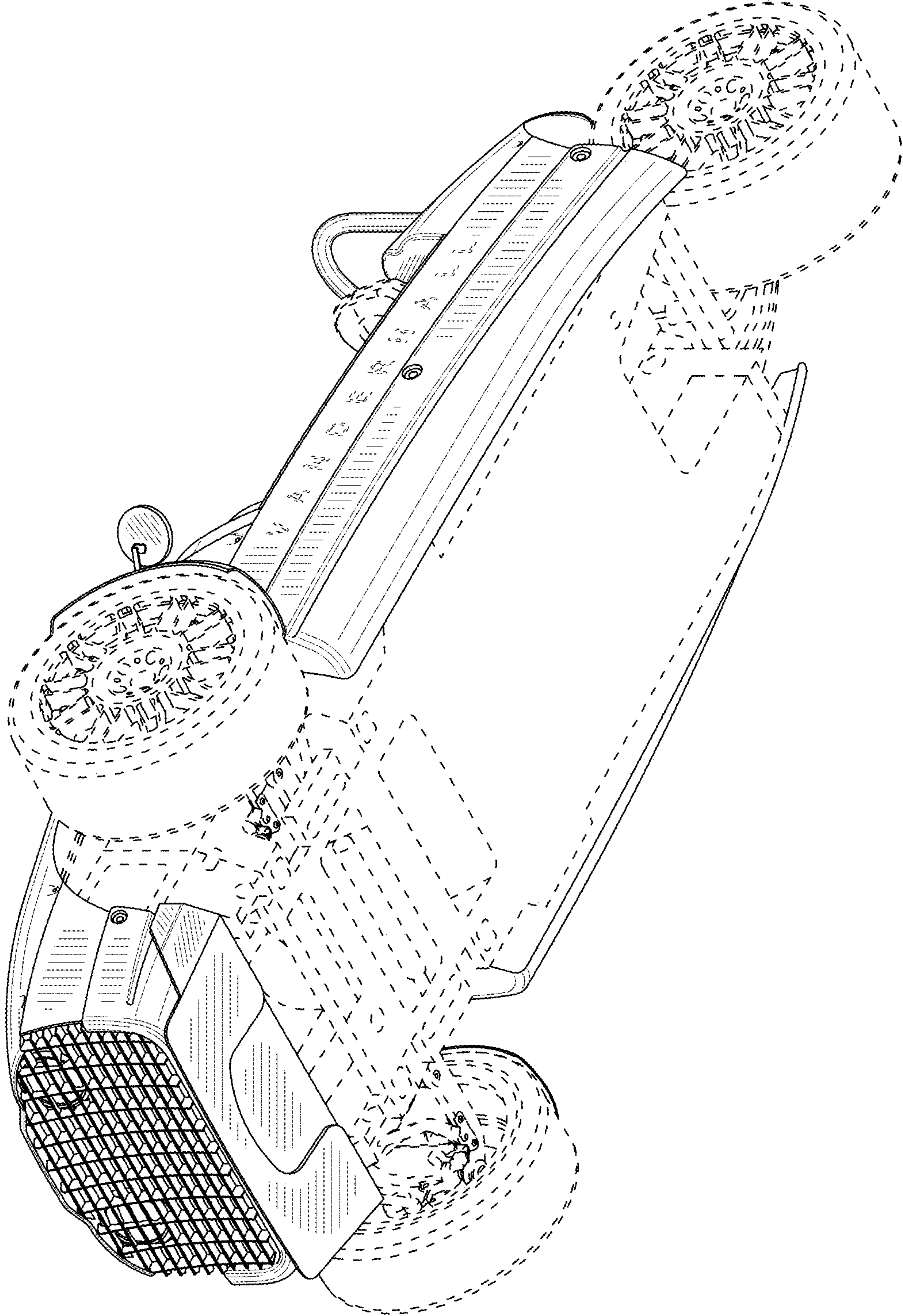

FIG. 5

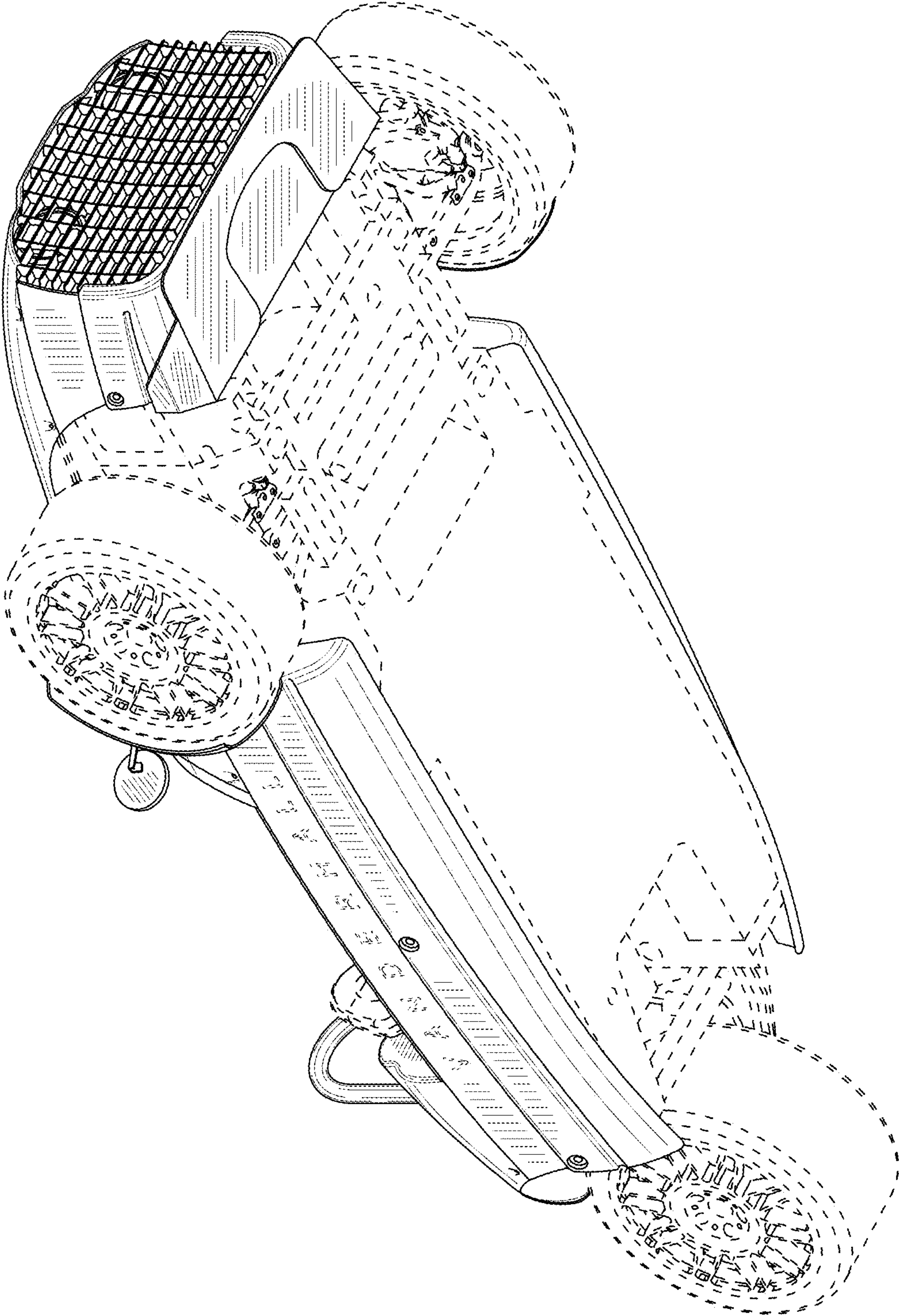

FIG. 6

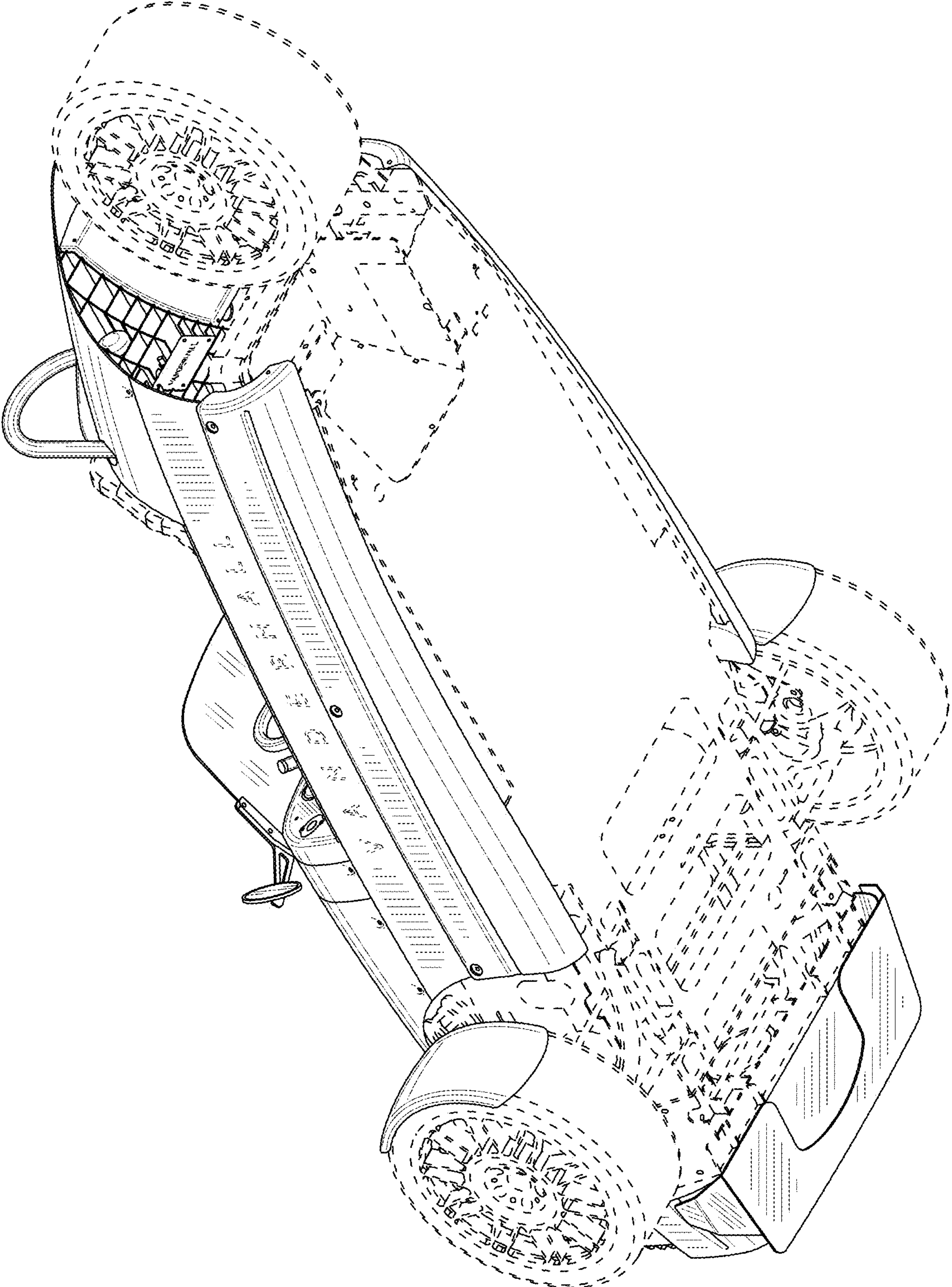

FIG. 7

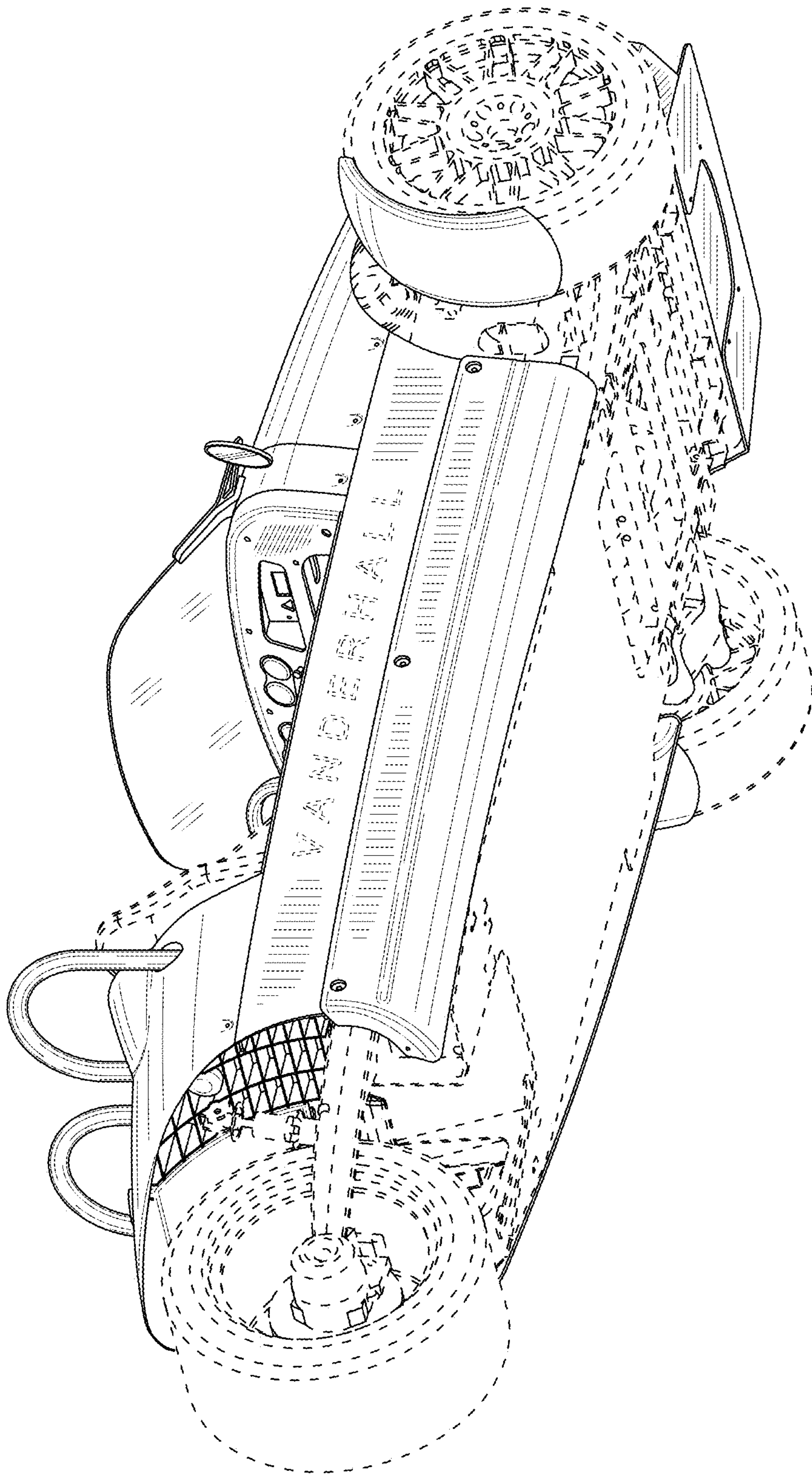

FIG. 8

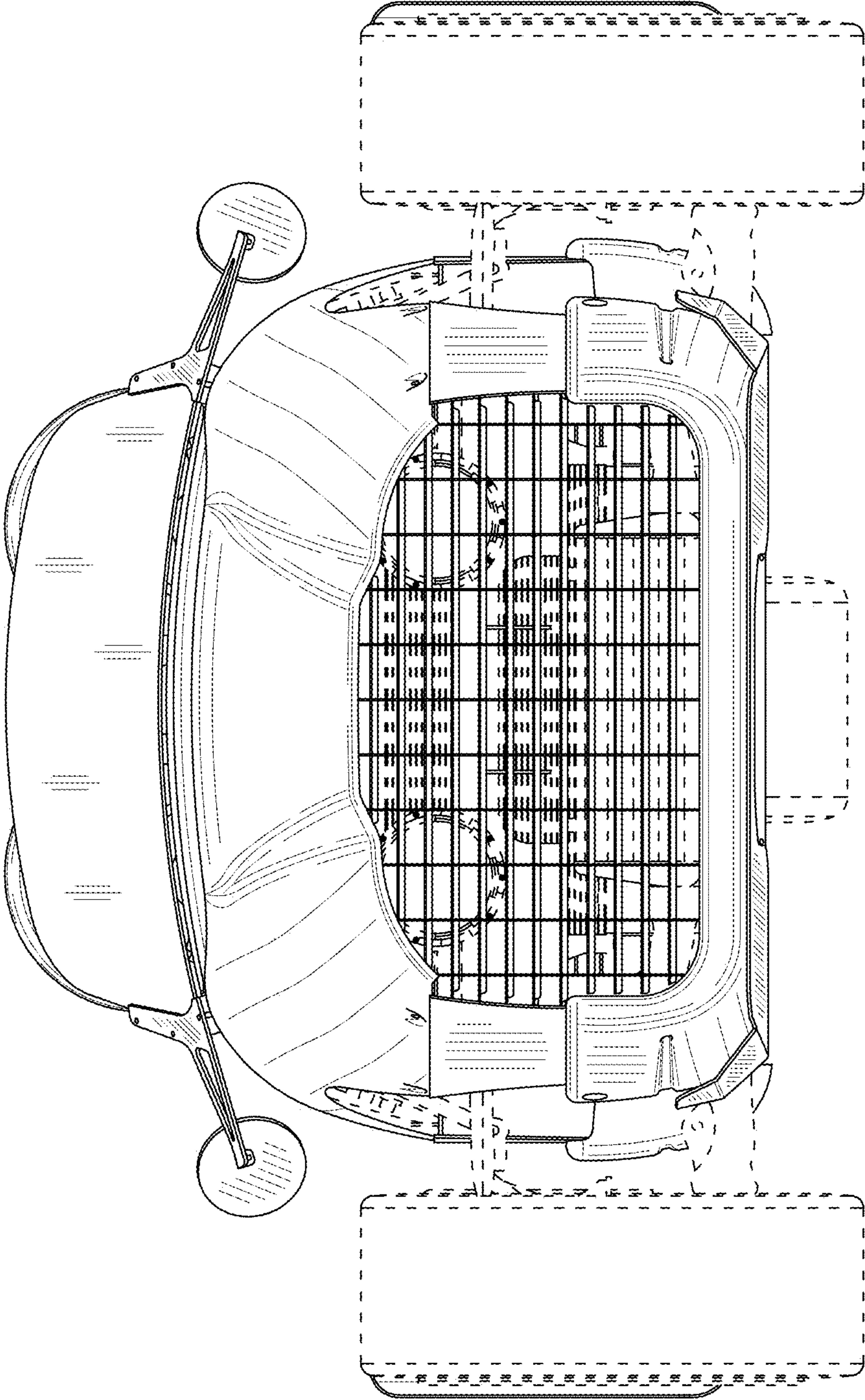

FIG. 9

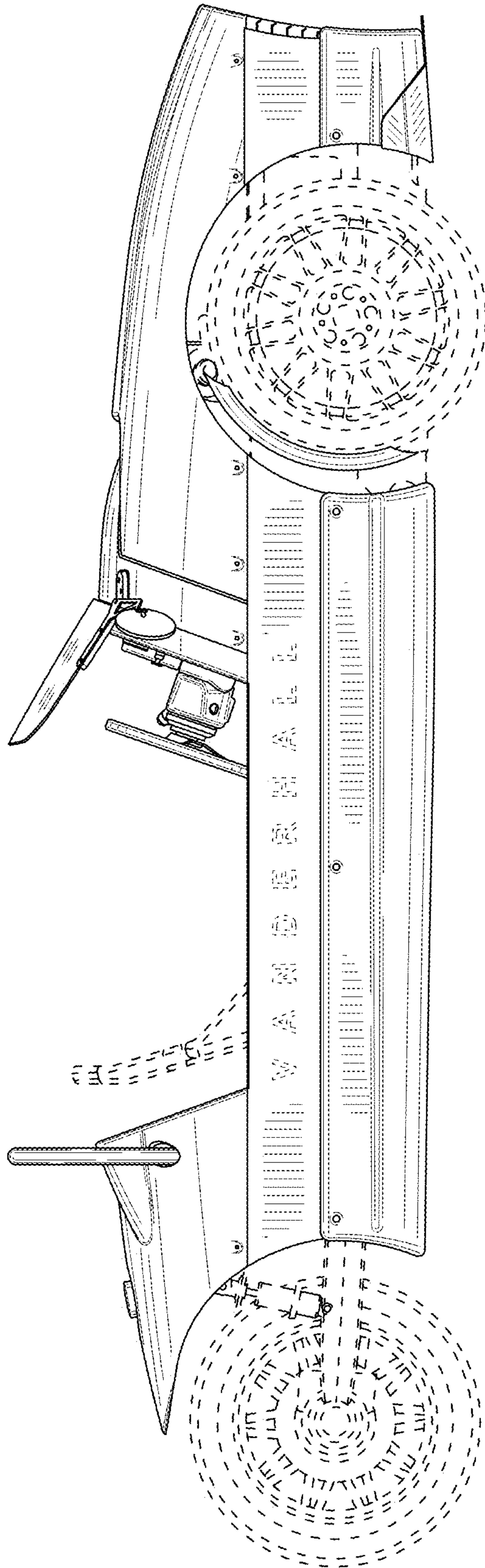

FIG. 10

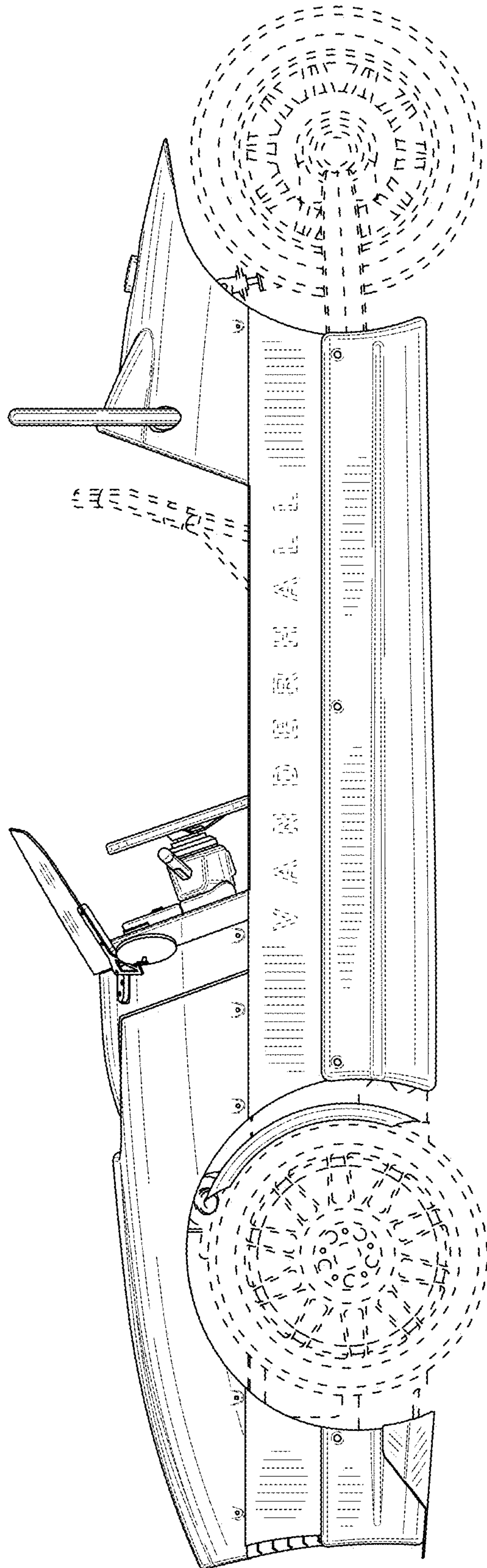

FIG. 11

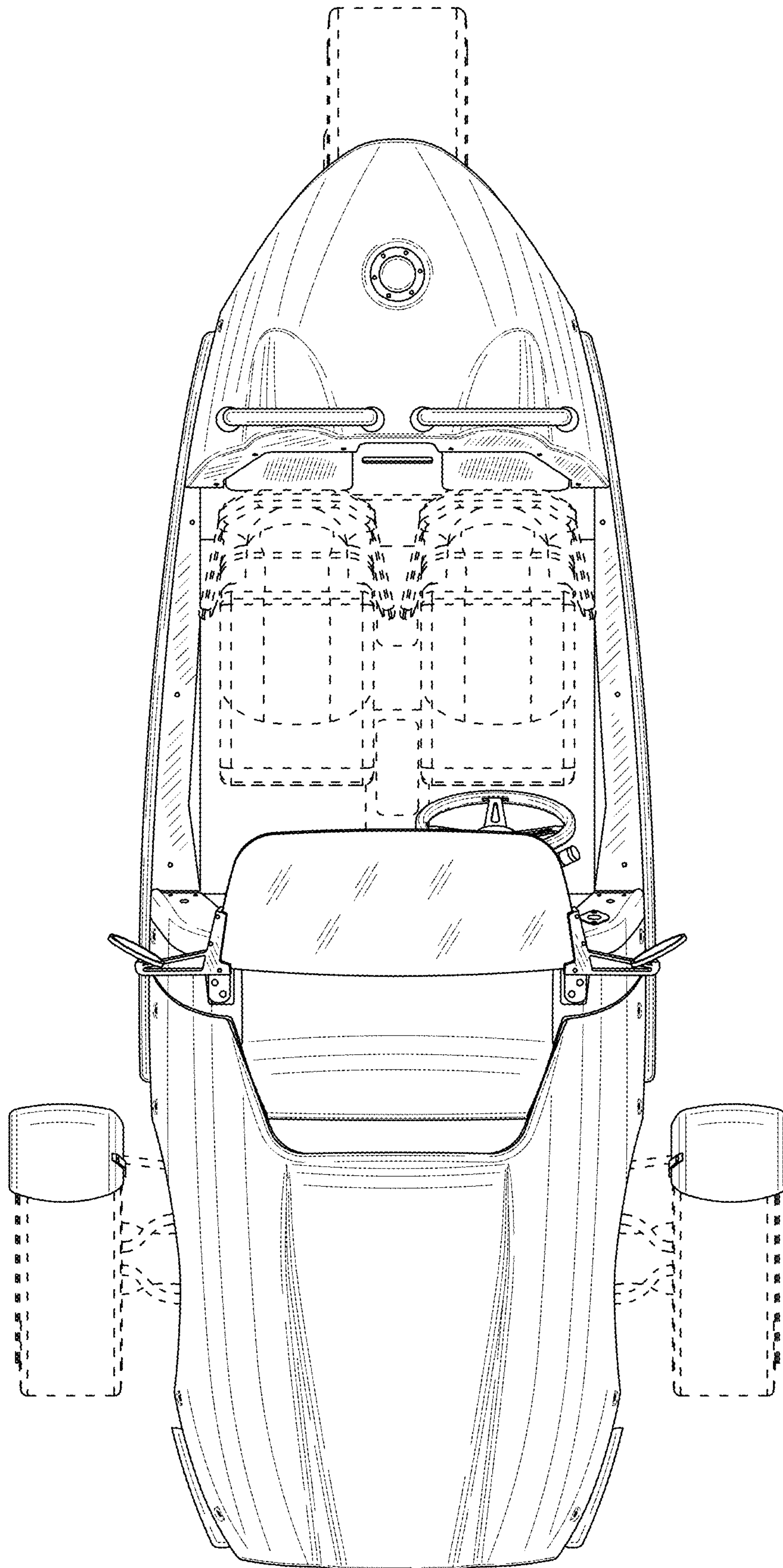

FIG. 12

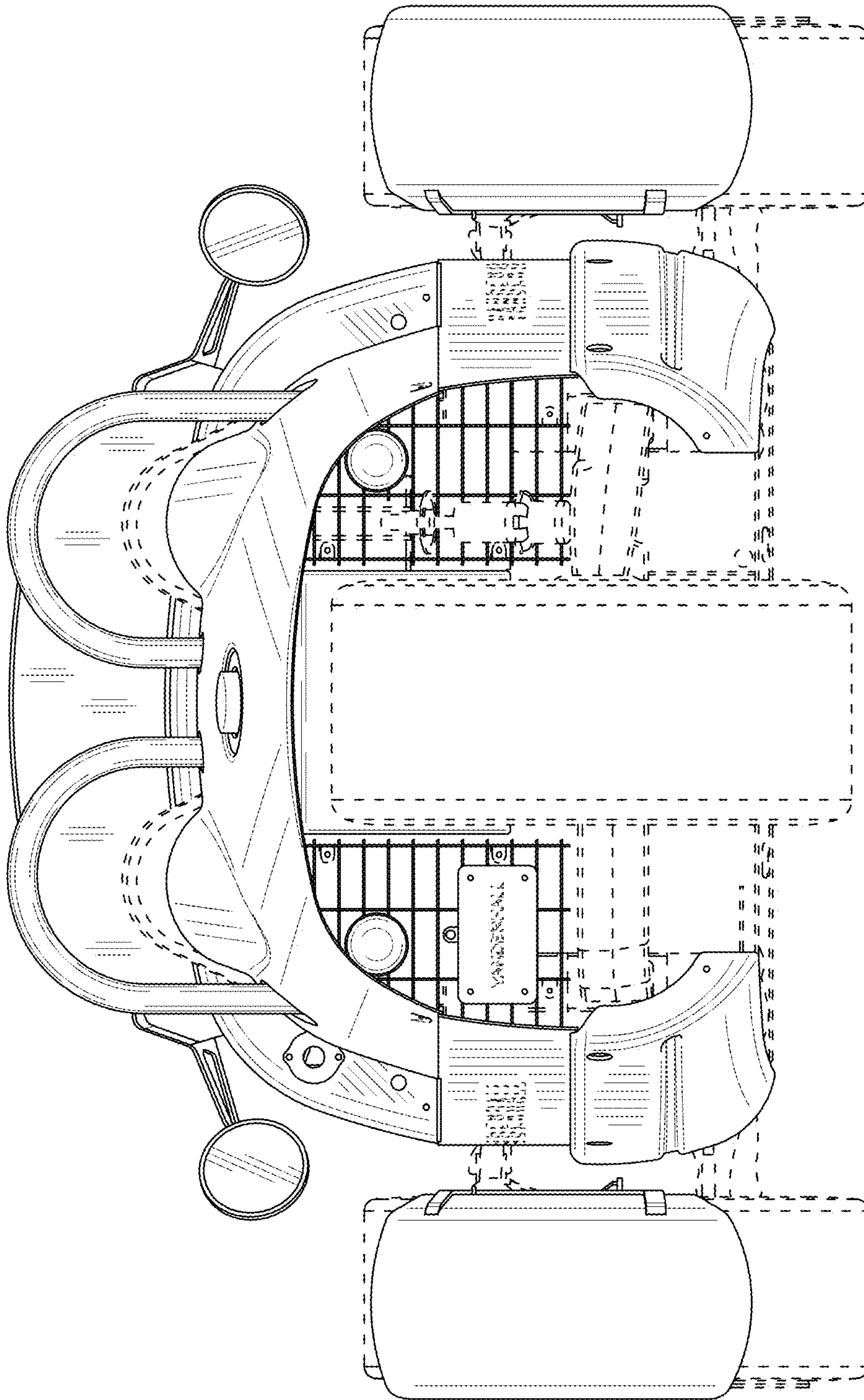

FIG. 13

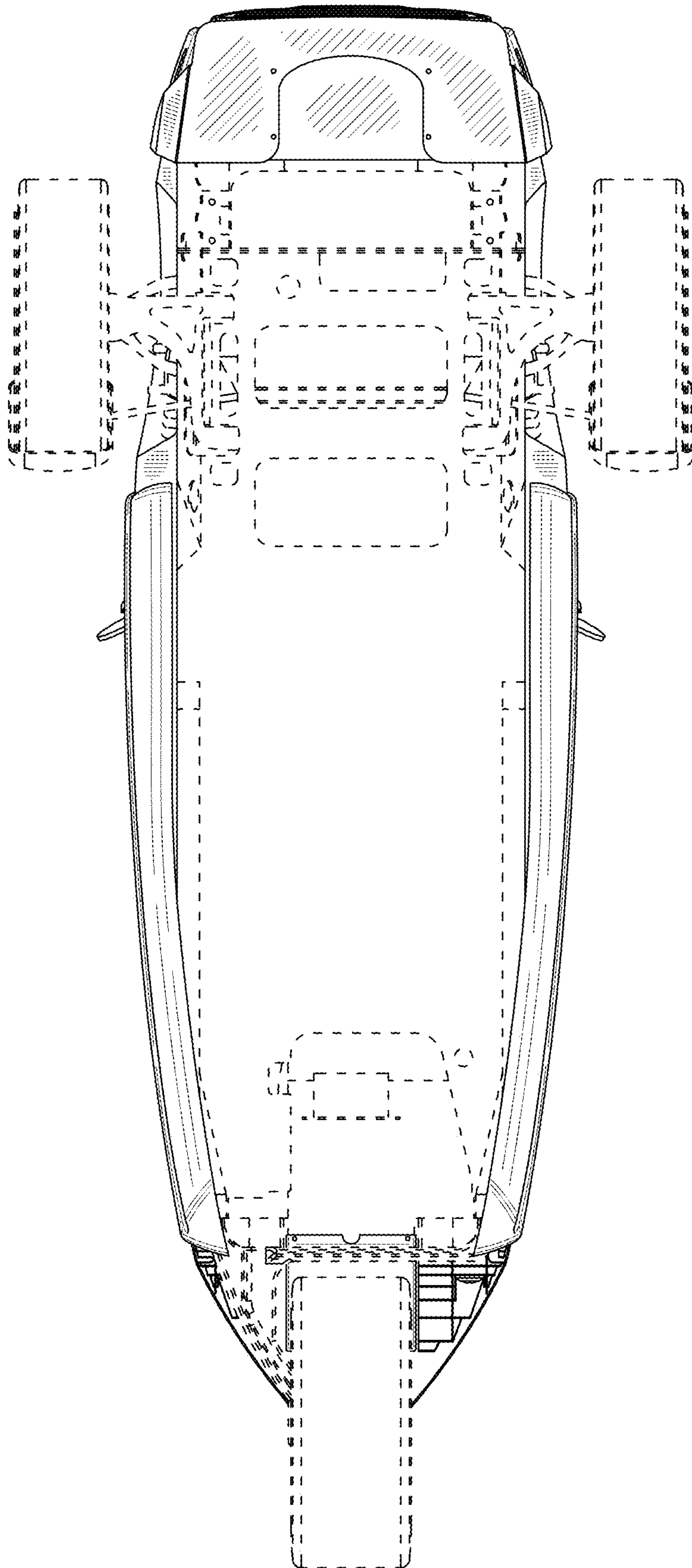

FIG. 14

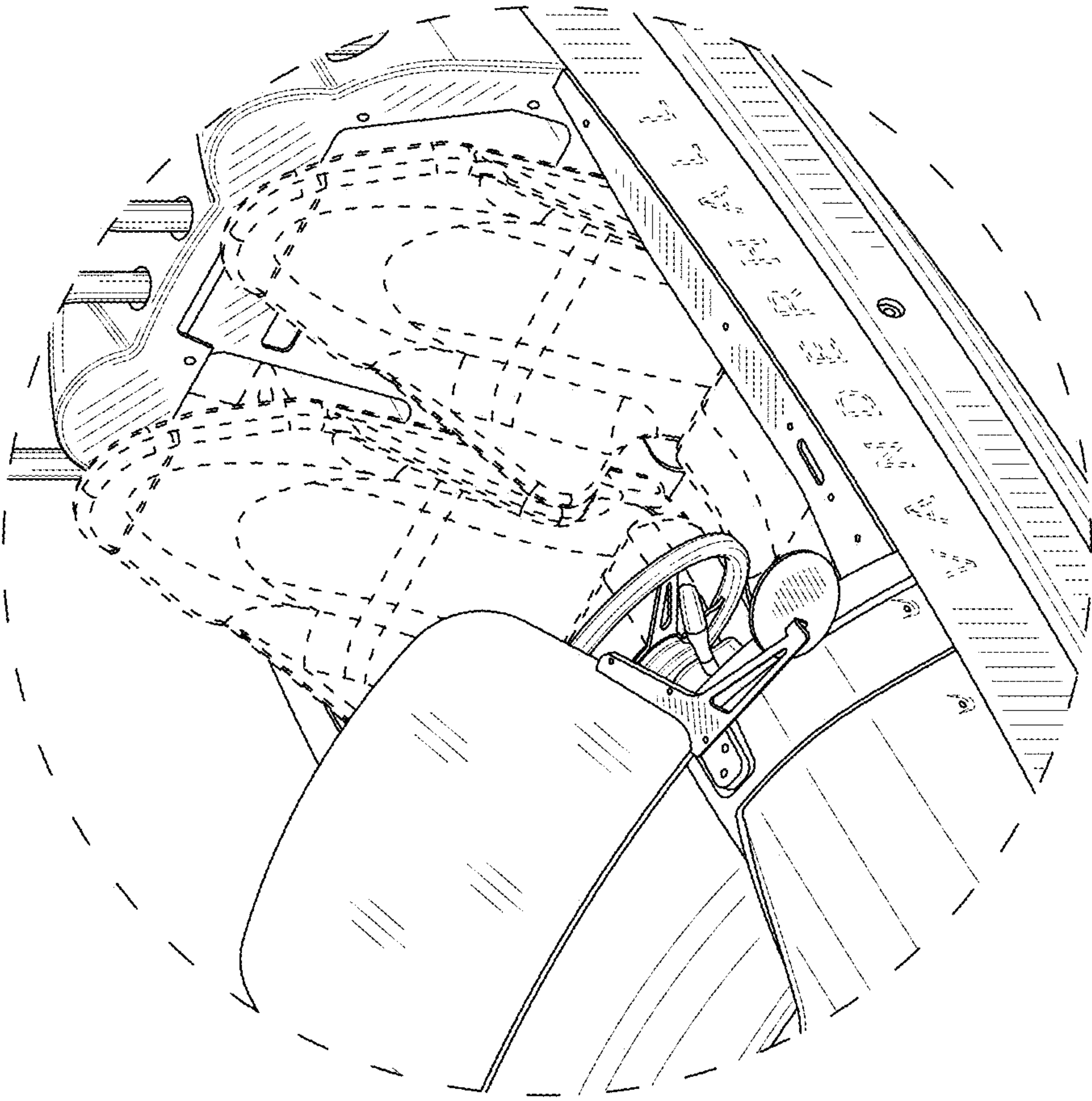

FIG. 15

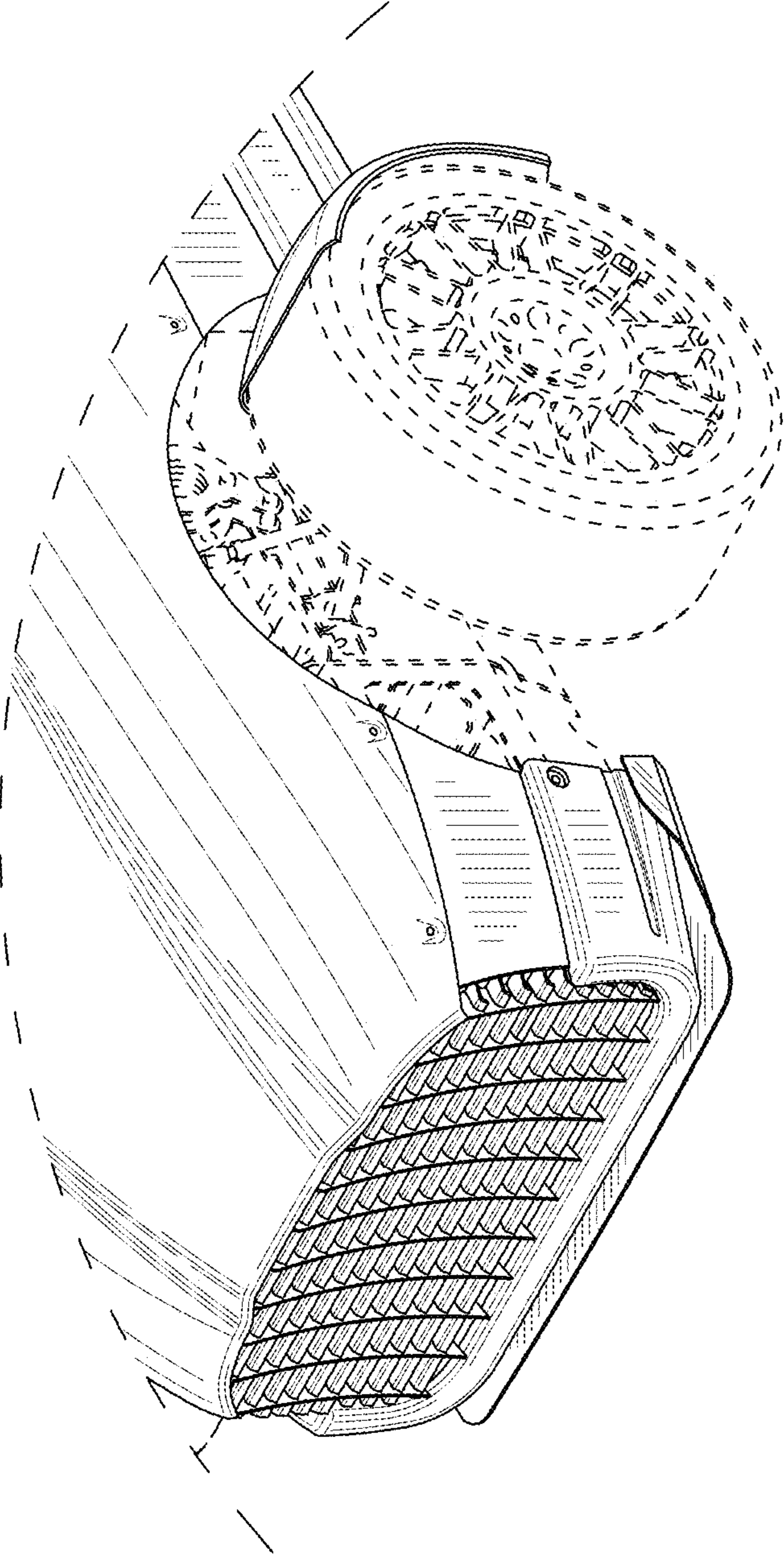

FIG. 16