

US00D873711S

(12) **United States Design Patent**
Hall

(10) **Patent No.:** **US D873,711 S**

(45) **Date of Patent:** **** Jan. 28, 2020**

(54) **REVERSE TRIKE ROADSTER**
(71) Applicant: **Stephen R. Hall**, Draper, UT (US)
(72) Inventor: **Stephen R. Hall**, Draper, UT (US)
(73) Assignee: **Hall Labs LLC**, Provo, UT (US)
(**) Term: **15 Years**
(21) Appl. No.: **29/626,832**

D469,037	S	*	1/2003	Hanagan	D12/85
D584,188	S	*	1/2009	Jenkins	D12/85
D589,844	S	*	4/2009	Aube	D12/85
D592,547	S	*	5/2009	Riley	D12/85
D592,548	S	*	5/2009	Aube	D12/85
D613,203	S	*	4/2010	Geslin	D12/85
D626,032	S	*	10/2010	Starr	D12/85
D633,821	S	*	3/2011	Hill	D12/85
D666,127	S	*	8/2012	Nam	D12/85
D678,124	S	*	3/2013	Canni	D12/85
D682,158	S	*	5/2013	Canni	D12/85
2012/0241239	A1	*	9/2012	Holroyd	B62K 5/05 180/210

(22) Filed: **Nov. 20, 2017**
(51) **LOC (12) Cl.** **12-08**
(52) **U.S. Cl.**
USPC **D12/85**
(58) **Field of Classification Search**
USPC D12/85, 86, 107, 131; D21/424, 433,
D21/434
CPC B62D 21/11; B62D 29/043; B62D 31/00;
B62D 49/00; B62D 61/065; B62L 3/00;
B62K 3/005; B62K 5/01; B62K 5/08;
B62K 5/027
See application file for complete search history.

* cited by examiner

Primary Examiner — Darlington Ly

(57) **CLAIM**

The ornamental design for a reverse trike roadster, as shown and described.

DESCRIPTION

FIG. 1 is a top, front, and left side perspective view of a reverse trike roadster showing my new design; FIG. 2 is a left side elevation view thereof; FIG. 3 is a right side elevation view thereof; FIG. 4 is a front elevation view thereof; FIG. 5 is a top plan view thereof; FIG. 6 is a rear elevation view thereof; FIG. 7 is a bottom, rear, and left side perspective view thereof; and, FIG. 8 is a bottom, rear, and right side perspective view thereof. The broken lines in the drawings illustrate portions of the reverse trike roadster that form no part of the claimed design.

(56) **References Cited**

U.S. PATENT DOCUMENTS

D260,871	S	*	9/1981	Cargile	D12/85
4,573,546	A	*	3/1986	Irimajiri	B62D 61/065 180/211
4,703,824	A	*	11/1987	Irimajiri	B62D 61/065 180/210
D404,688	S	*	1/1999	Hanagan	D12/85
6,015,022	A	*	1/2000	Thuliez	B62D 21/04 180/210
D424,979	S	*	5/2000	Hanagan	D12/85
D427,548	S	*	7/2000	Sacco	D12/85
D449,018	S	*	10/2001	Musser	D12/85

1 Claim, 8 Drawing Sheets

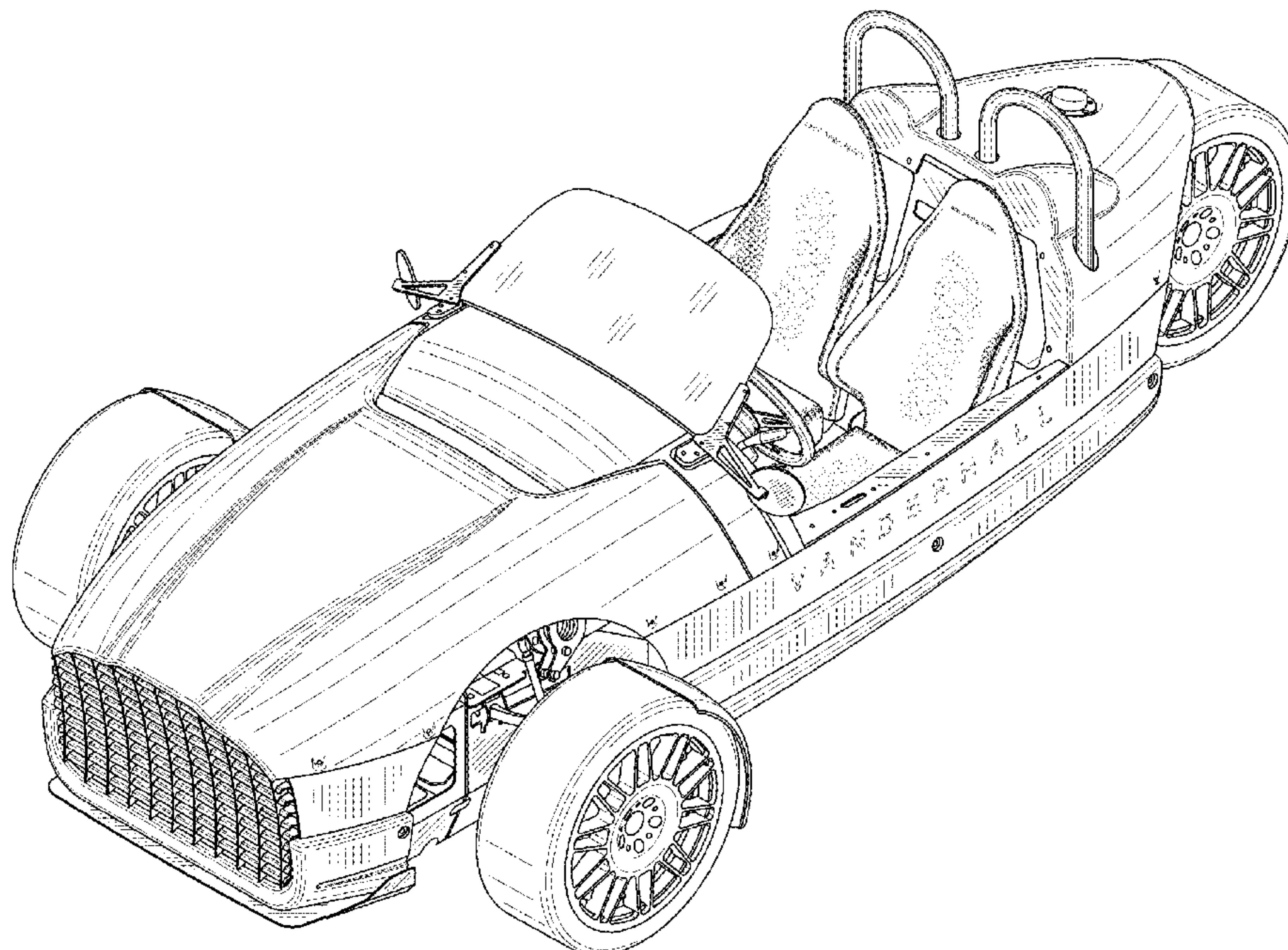

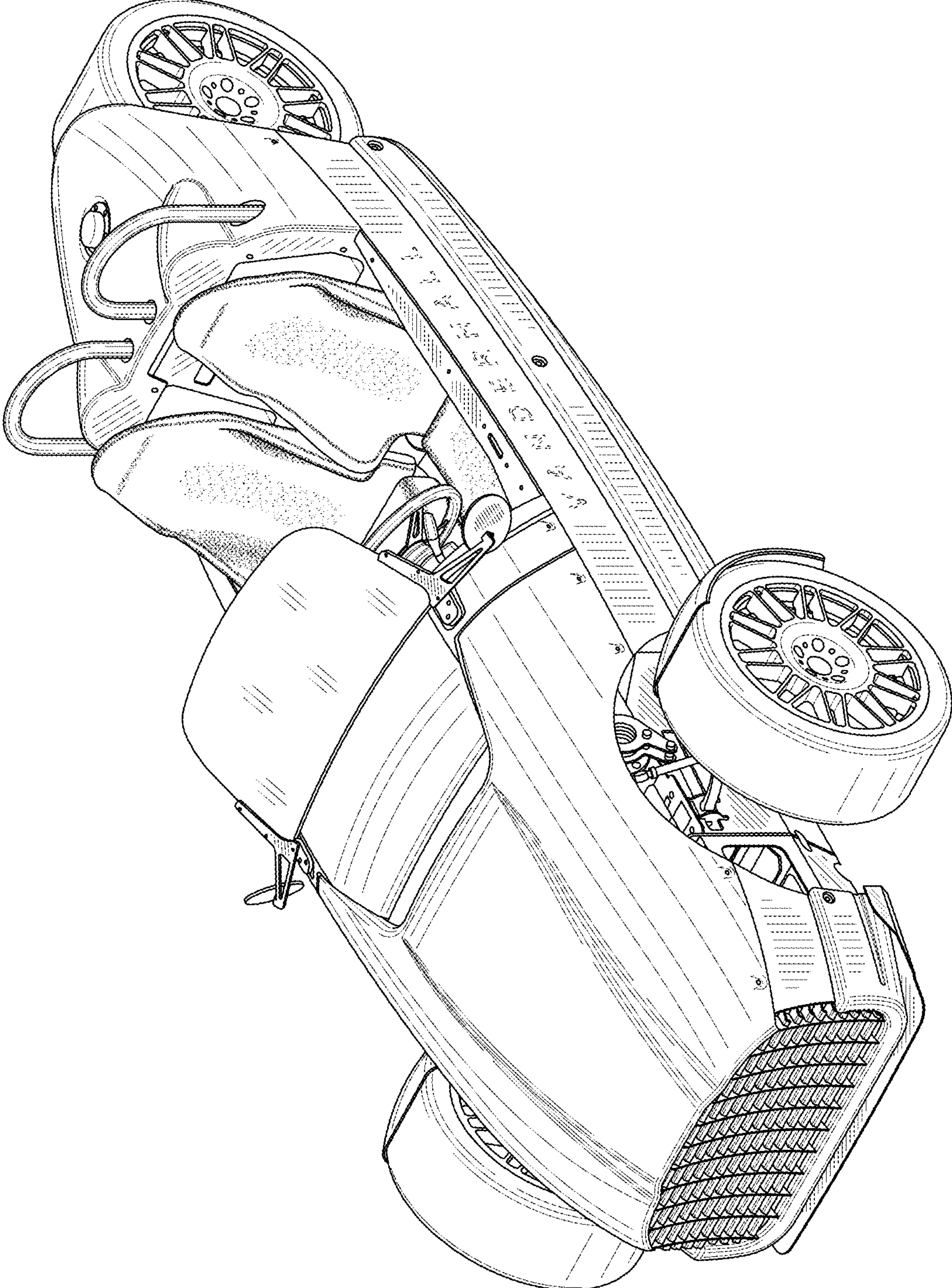

FIG. 1

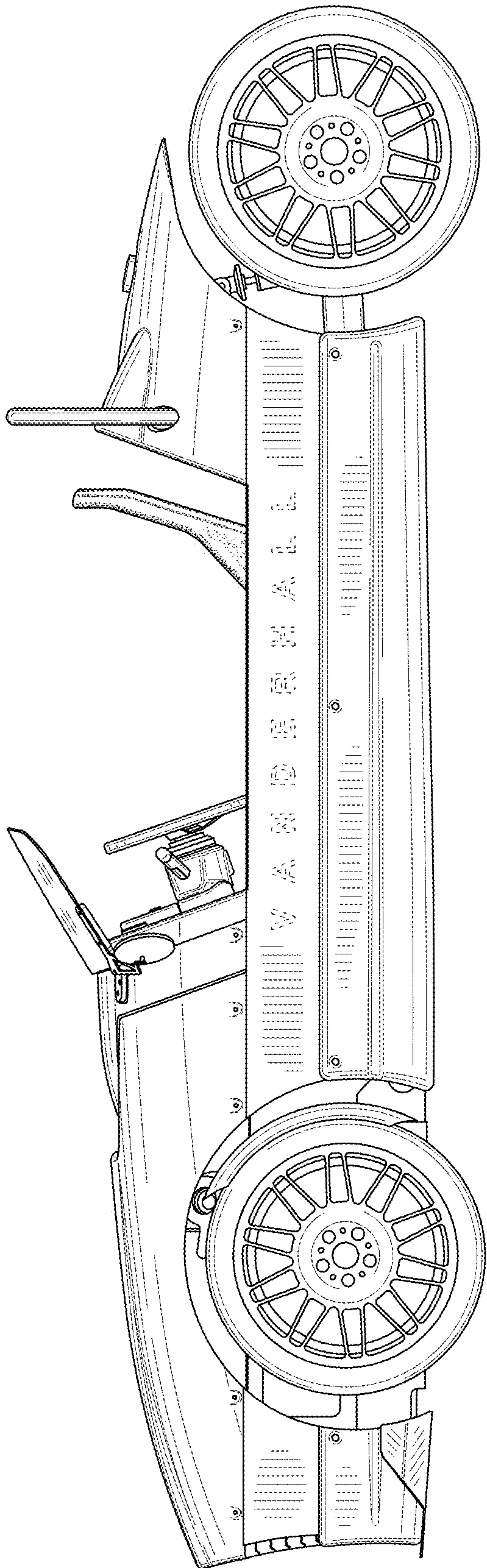

FIG. 2

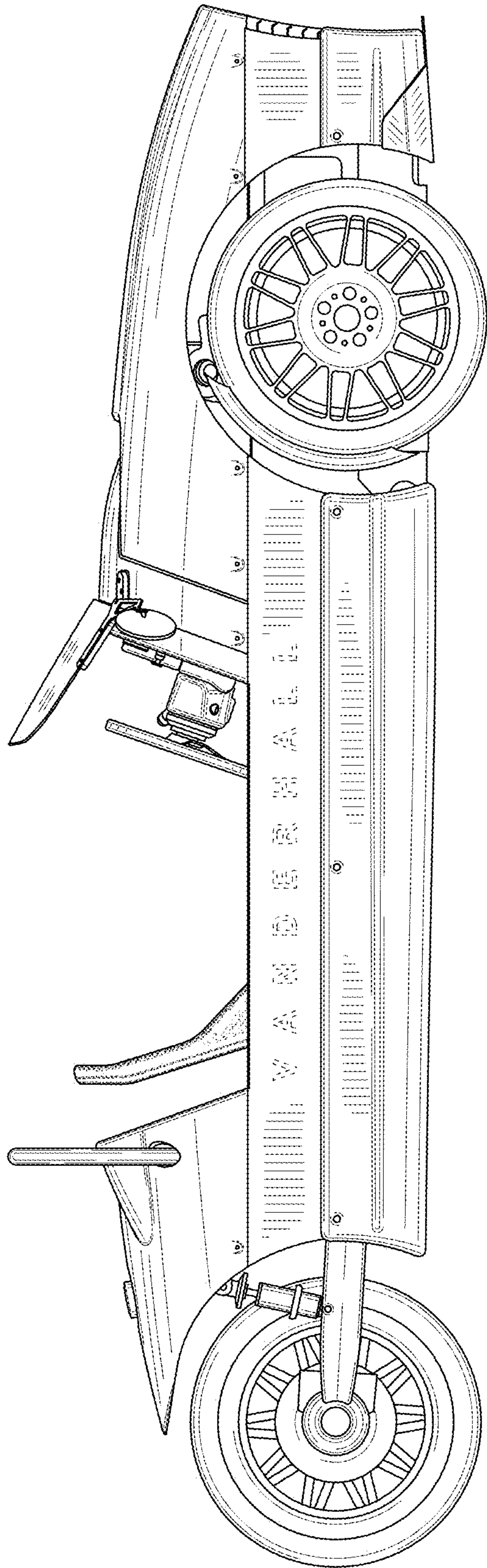

FIG. 3

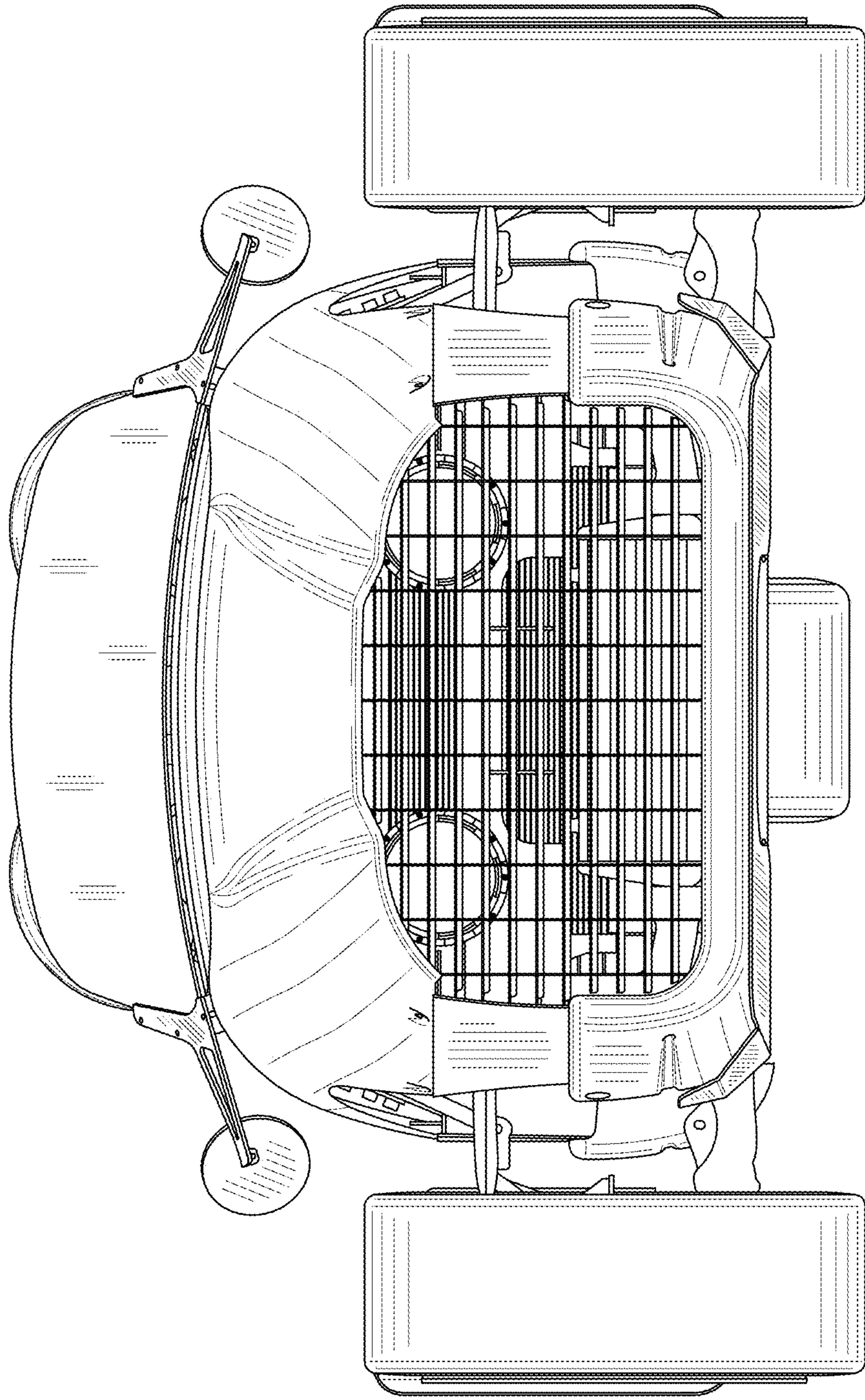

FIG. 4

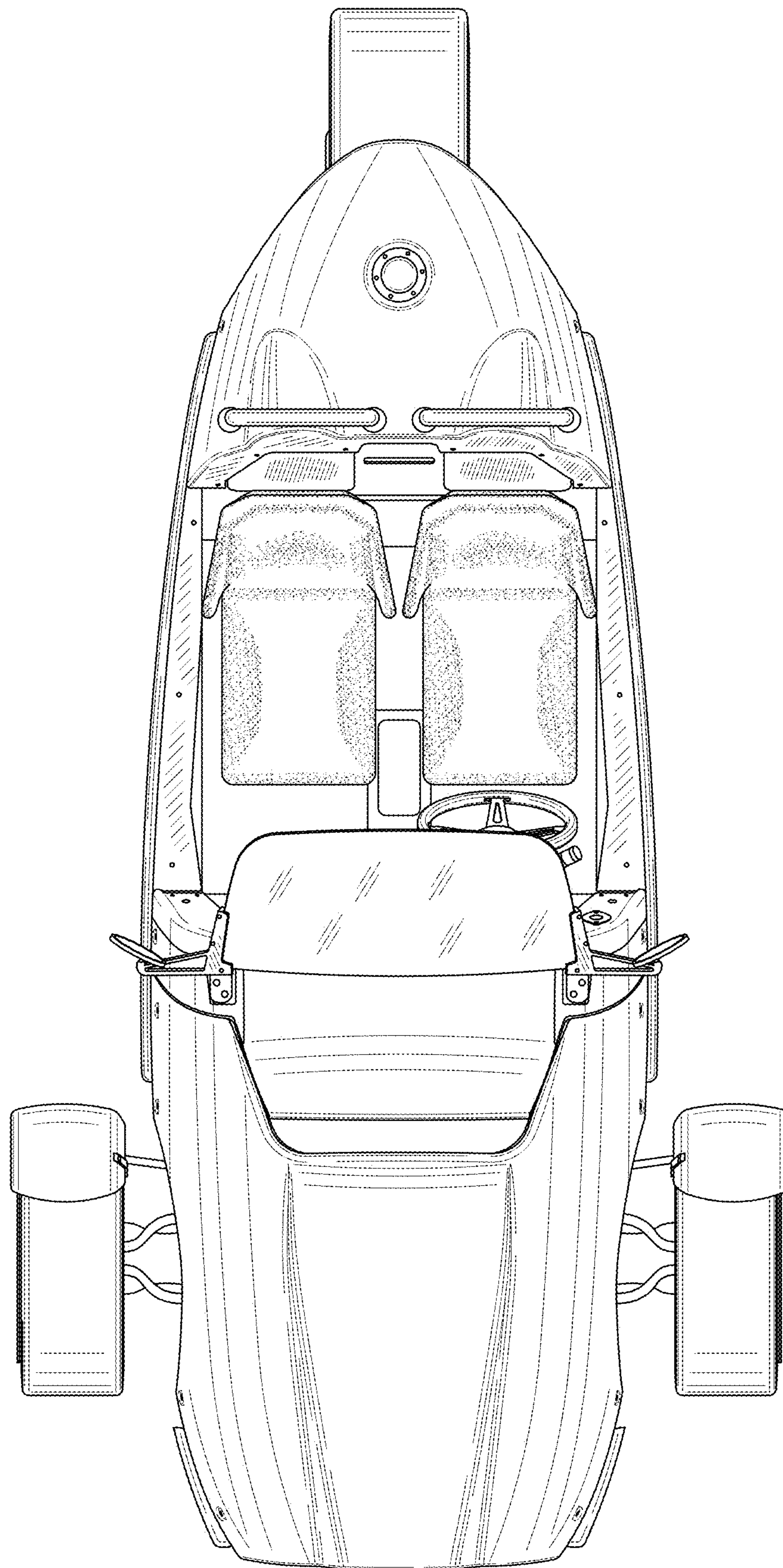

FIG. 5

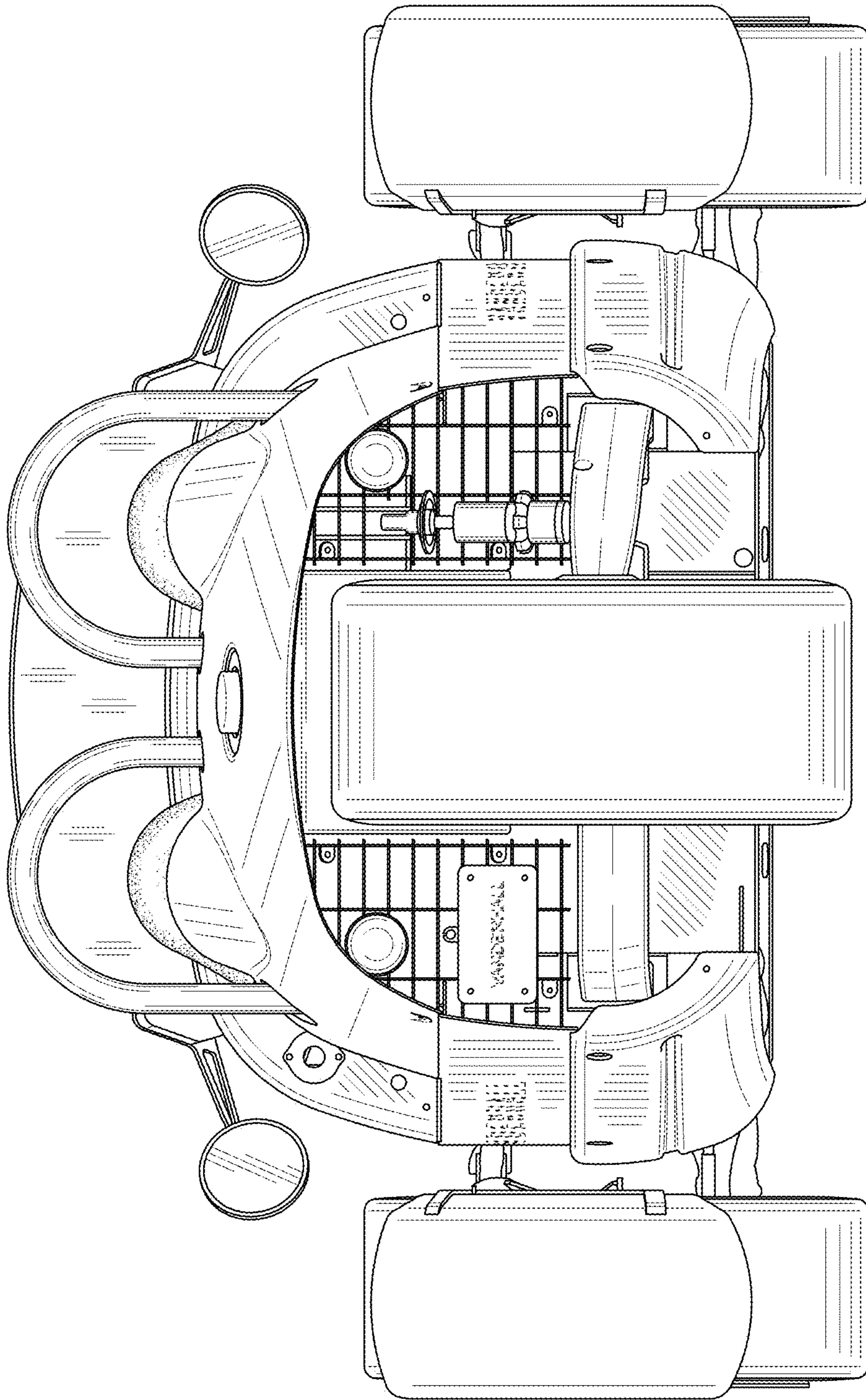

FIG. 6

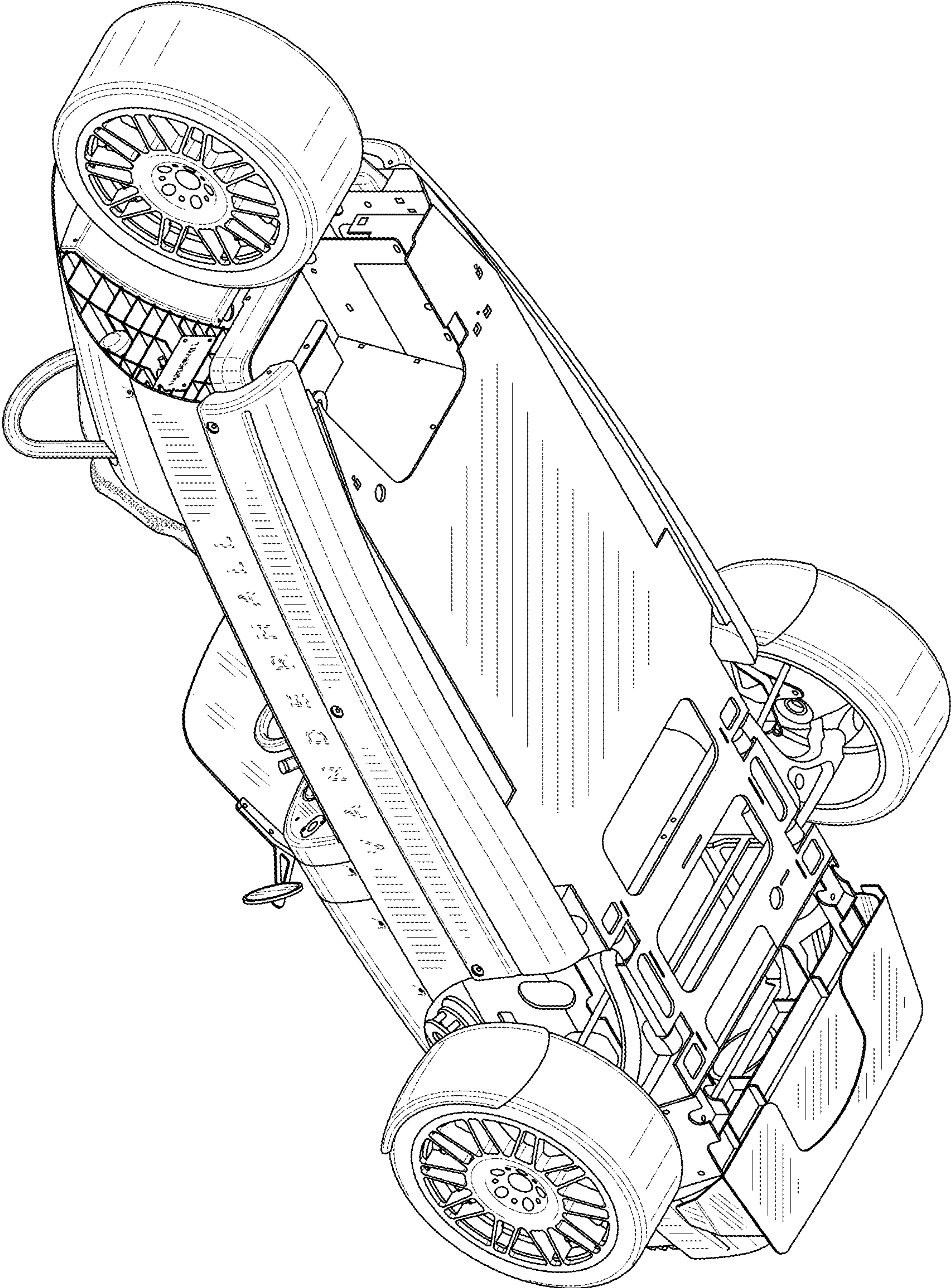

FIG. 7

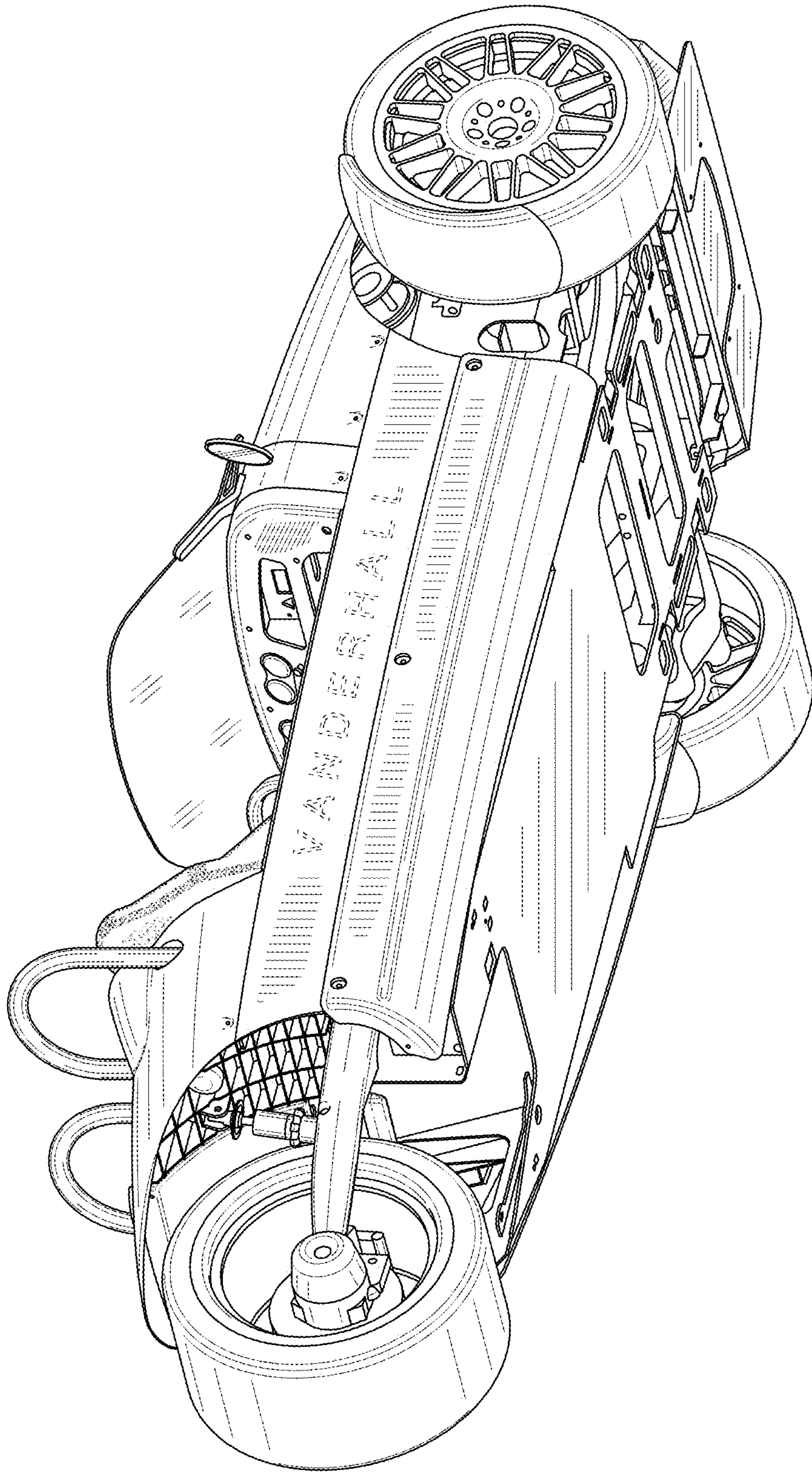

FIG. 8