



US00D873199S

(12) **United States Design Patent** (10) **Patent No.:** **US D873,199 S**
Akputat (45) **Date of Patent:** **** Jan. 21, 2020**

(54) **YACHT**
 (71) Applicant: **Ahmet Burak Akputat**, Istanbul (TR)
 (72) Inventor: **Ahmet Burak Akputat**, Istanbul (TR)
 (**) Term: **15 Years**
 (21) Appl. No.: **35/505,420**
 (22) Filed: **Mar. 16, 2018**

4,919,063 A * 4/1990 Hall B63B 1/107
 114/61.14
 D315,137 S * 3/1991 Runte D12/303
 D315,892 S * 4/1991 Tollefson D12/315
 D319,619 S * 9/1991 Kotzebue D12/315
 D326,638 S * 6/1992 Farrell D12/315
 D488,841 S * 4/2004 Yuen D21/542
 D548,666 S * 8/2007 Laupman D12/300
 D553,071 S * 10/2007 de Rover D12/315
 D574,313 S * 8/2008 de Rover D12/300
 D587,641 S * 3/2009 Bouckaert D12/300
 D739,332 S * 9/2015 Can D12/315

* cited by examiner

(80) **Hague Agreement Data**
 Int. Filing Date: **Mar. 16, 2018**
 Int. Reg. No.: **DM/102060**
 Int. Reg. Date: **Mar. 16, 2018**
 Int. Reg. Pub. Date: **Aug. 10, 2018**

Primary Examiner — Darlington Ly

(57) **CLAIM**

The ornamental design for a yacht, as shown and described.

DESCRIPTION

(30) **Foreign Application Priority Data**
 Sep. 19, 2017 (TR) 2017 06022
 (51) **LOC (12) Cl.** **12-06**
 (52) **U.S. Cl.**
 USPC **D12/315**
 (58) **Field of Classification Search**
 USPC D12/300, 301, 304, 315, 317, 318;
 D21/542, 543
 CPC B63B 1/00; B63B 1/04; B63B 1/06; B63B
 1/08; B63B 1/10; B63B 1/38
 See application file for complete search history.

1.1 is a front, right and top perspective view of a yacht showing my new design;
 1.2 is a rear, left and top perspective view thereof;
 1.3 is another front, right and top perspective view thereof;
 1.4 is a perspective view thereof shown in a first state where a starboard hatchway at a bow port and a beach club at a stern are open;
 1.5 is a perspective view thereof shown in a second state where the starboard hatchway at the bow port and the beach club at the stern are closed;
 1.6 is a partial enlarged view showing the stern in the first state; and,
 1.7 is another partial enlarged view showing the stern portion in a third state where a helicopter landing platform and the beach club at the stern are open.
 The broken lines in the drawings illustrate portions of the yacht that form no part of the claimed design.

(56) **References Cited**
 U.S. PATENT DOCUMENTS
 4,383,828 A * 5/1983 Wynne B63B 1/08
 114/343
 D290,949 S * 7/1987 Scarboro D12/315

1 Claim, 7 Drawing Sheets

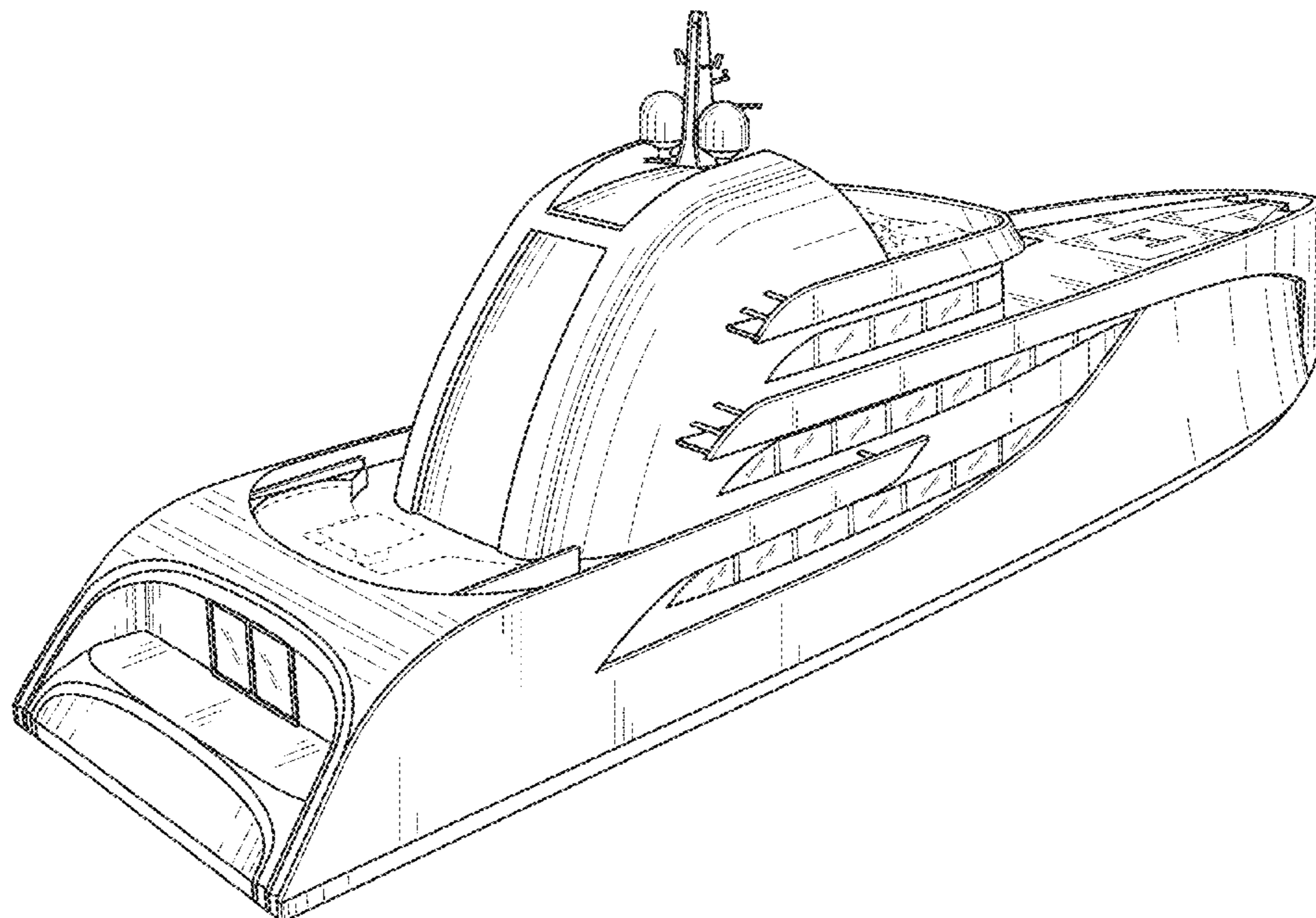

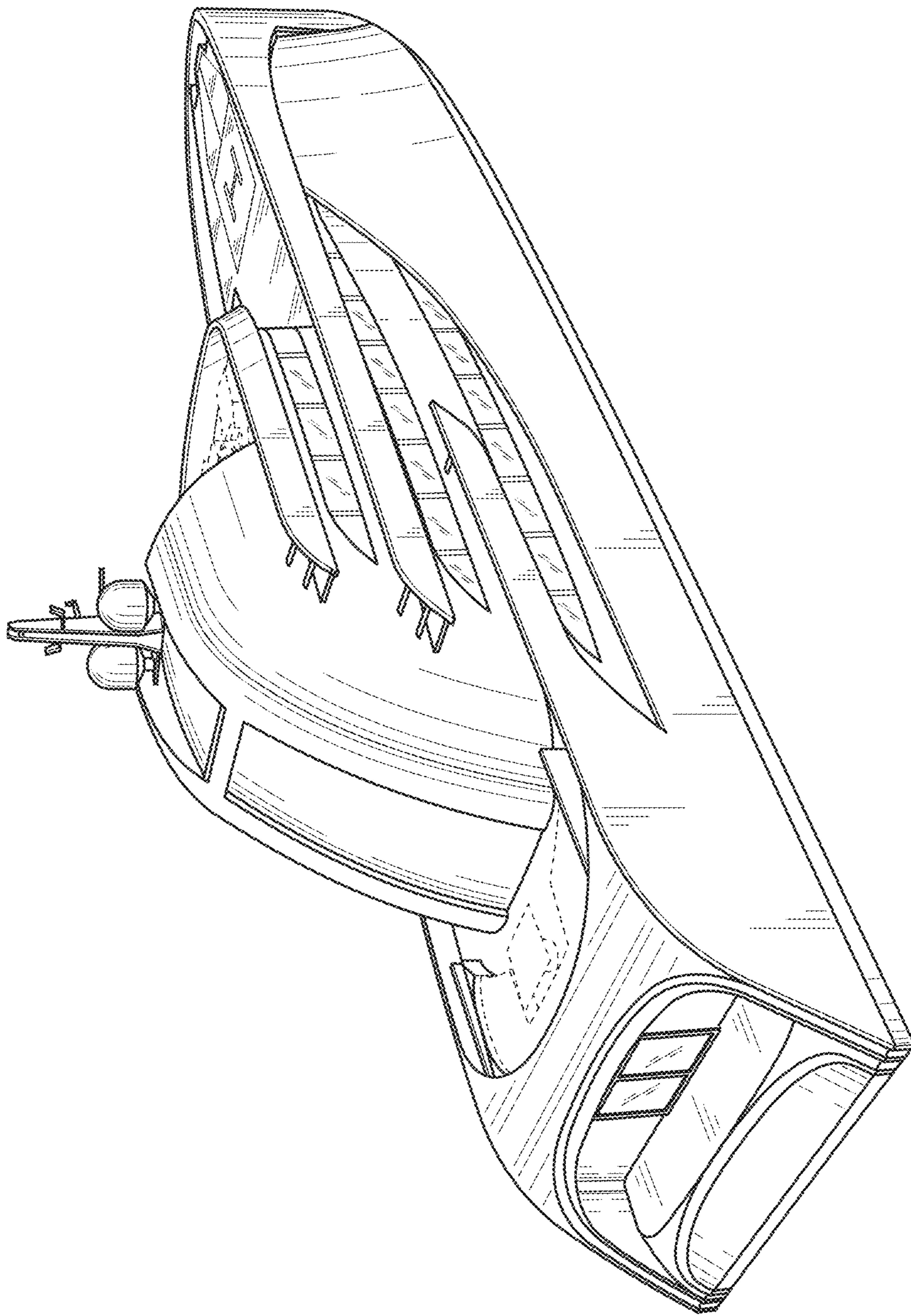

1.1

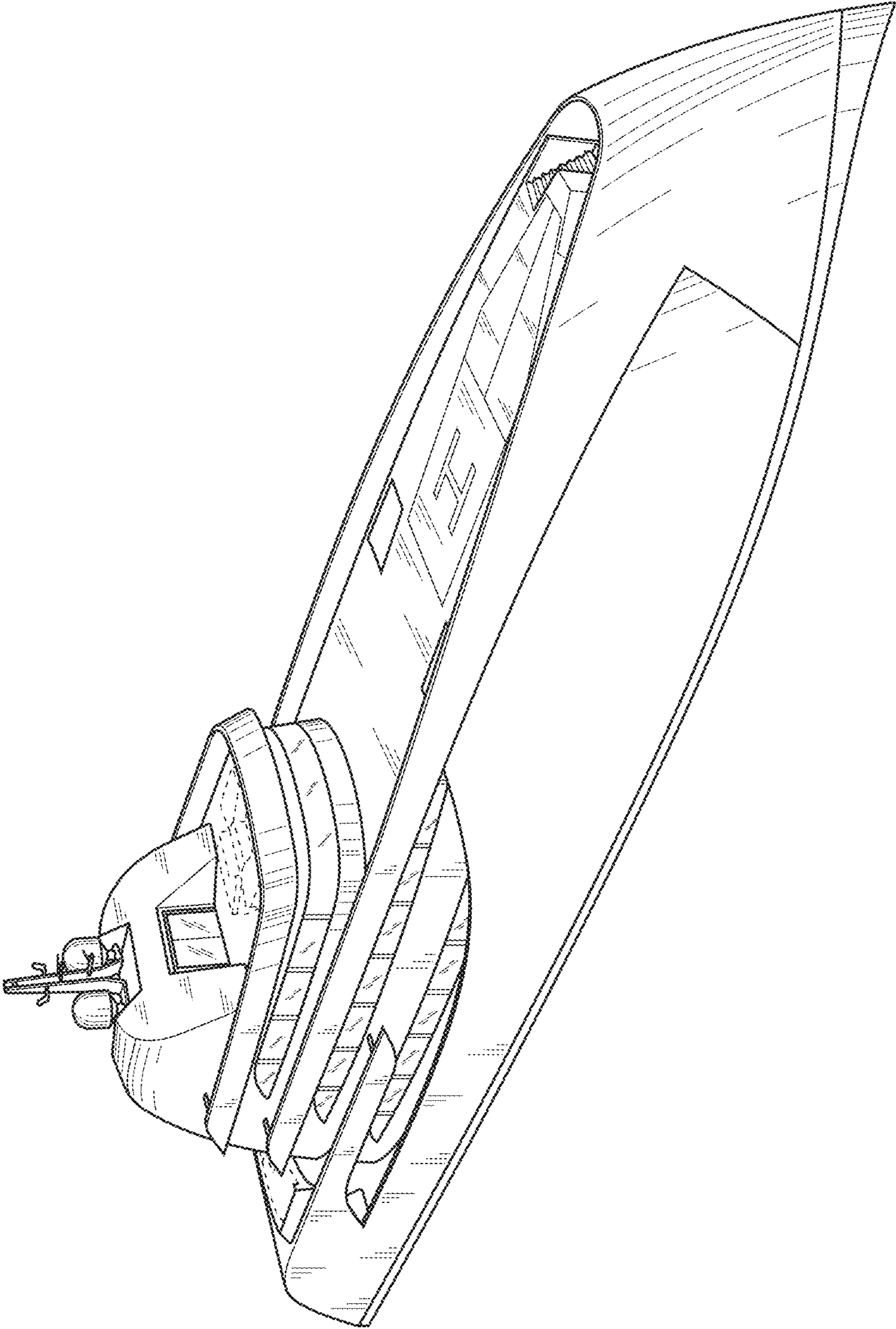

1.2

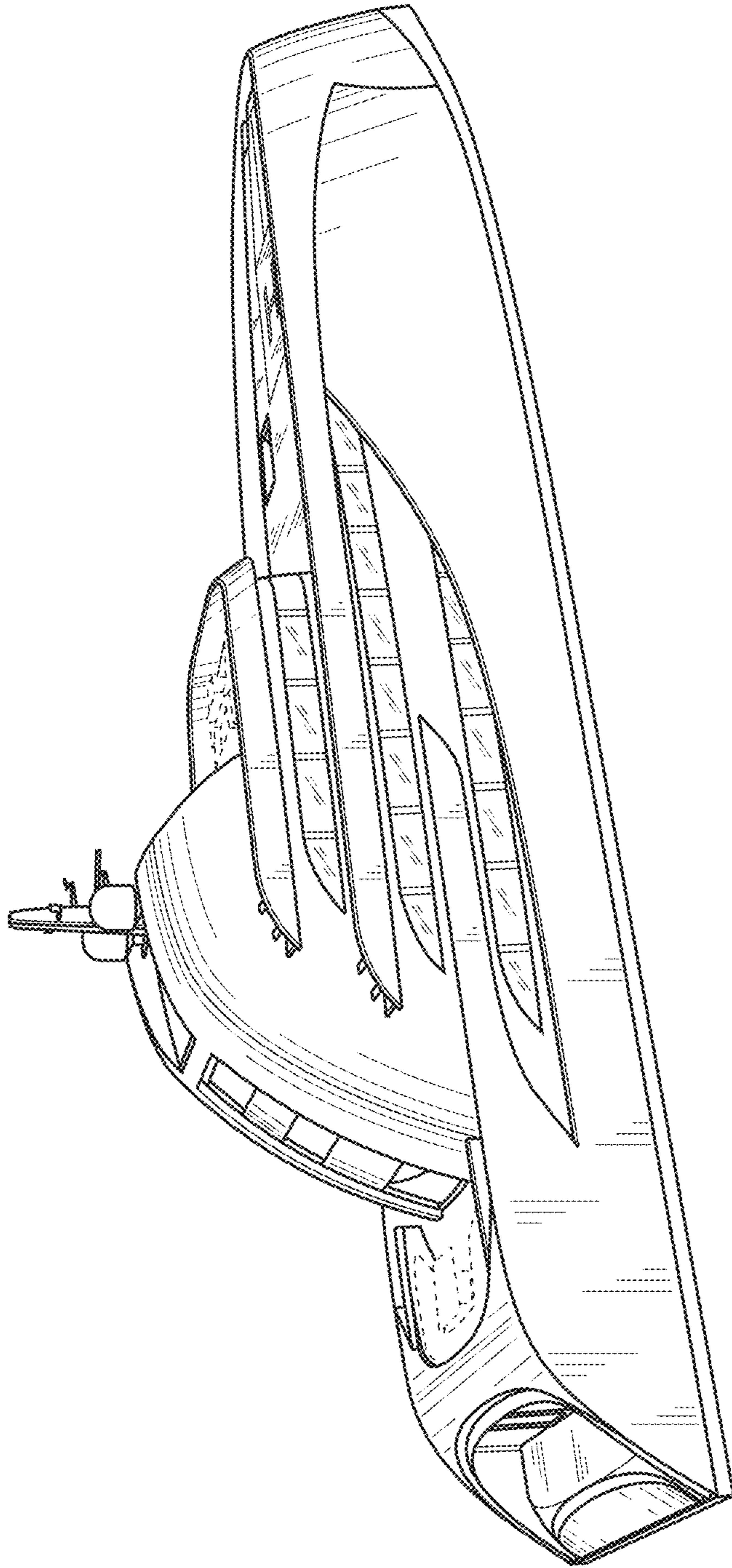

1.3

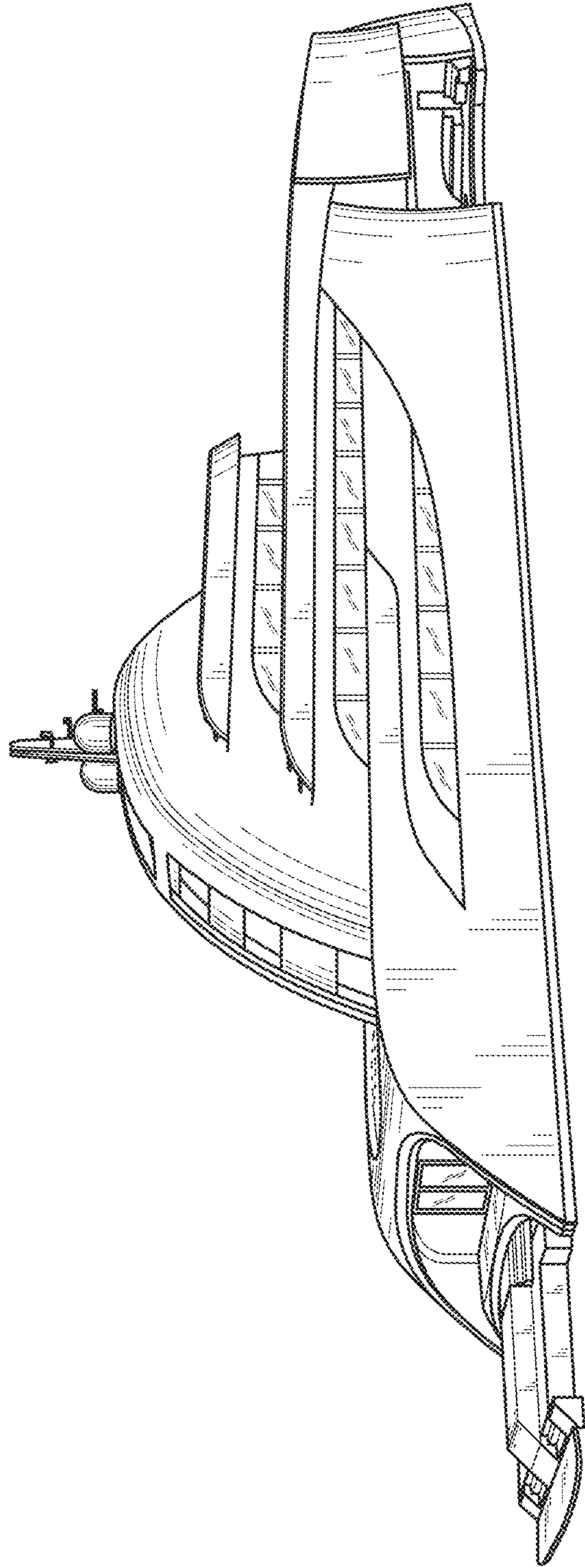

1.4

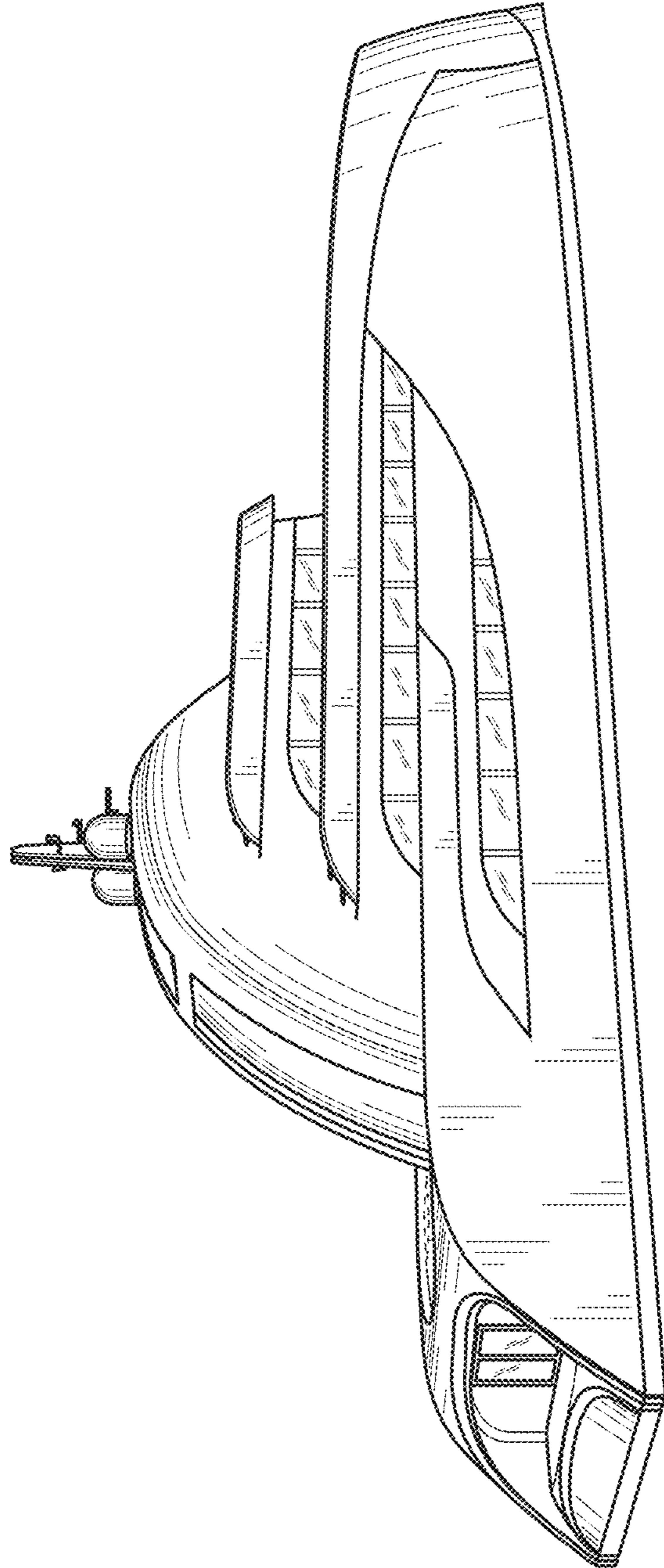

1.5

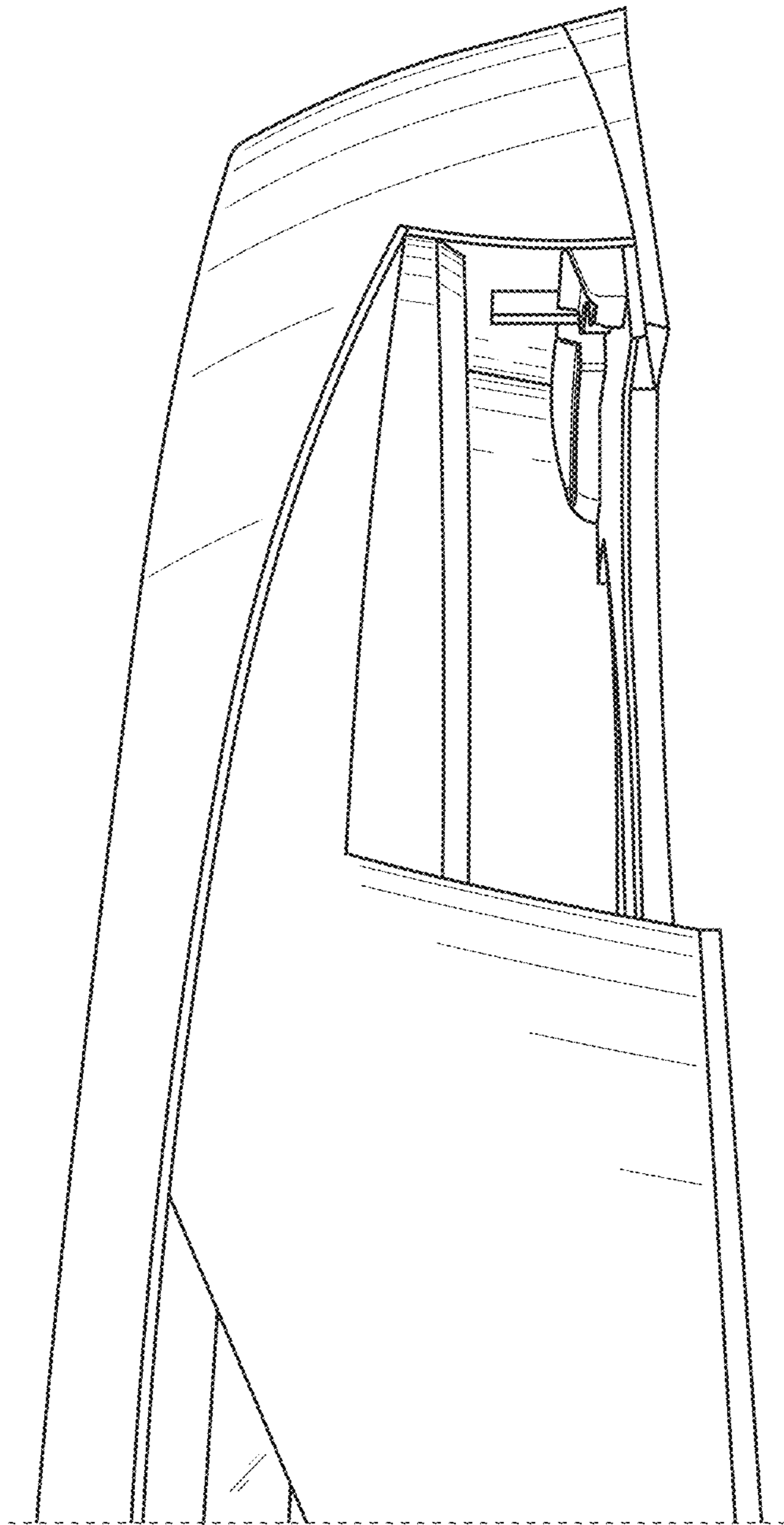

1.6

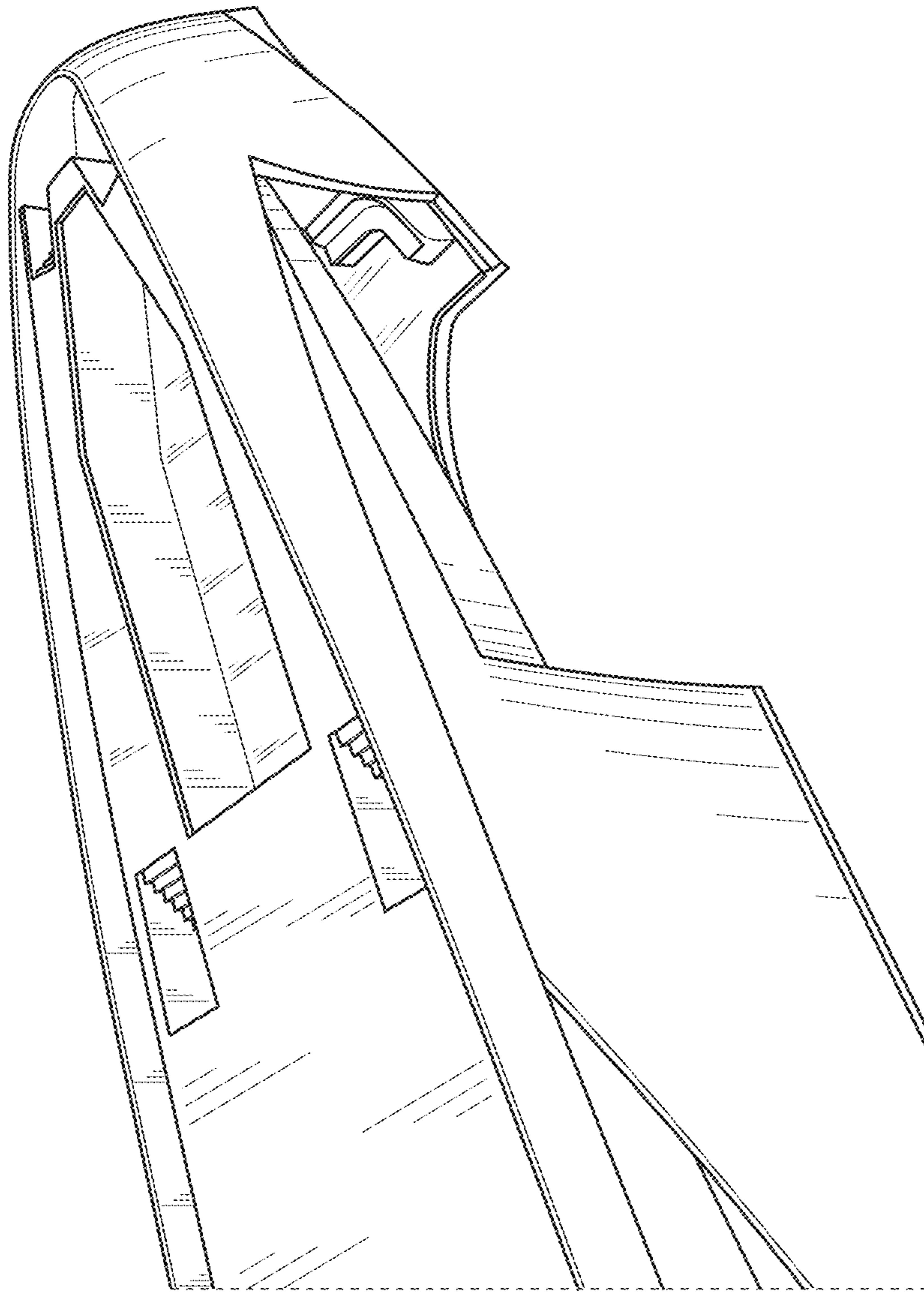

1.7