



US00D873196S

(12) **United States Design Patent**  
**Harrington**

(10) **Patent No.:** **US D873,196 S**

(45) **Date of Patent:** **\*\* Jan. 21, 2020**

(54) **WHEEL CHOCK**

(71) Applicant: **Sean Farrell Harrington**, Danville, CA (US)

(72) Inventor: **Sean Farrell Harrington**, Danville, CA (US)

(\*\*) Term: **15 Years**

(21) Appl. No.: **29/663,334**

(22) Filed: **Sep. 13, 2018**

(51) **LOC (12) Cl.** ..... **12-16**

(52) **U.S. Cl.**  
USPC ..... **D12/217**

(58) **Field of Classification Search**  
USPC ..... D12/217, 400, 223; D34/31, 32, 38;  
D25/102, 113; D8/354

See application file for complete search history.

(56) **References Cited**

U.S. PATENT DOCUMENTS

D268,409 S *	3/1983	Moussette	.....	D12/217
D328,588 S *	8/1992	Mitchell	.....	D12/217
D385,526 S *	10/1997	Hinkle	.....	D12/217
6,336,527 B1 *	1/2002	Metz	.....	B60T 3/00 188/32
6,390,245 B1 *	5/2002	Metz	.....	B60T 3/00 188/32
D489,310 S *	5/2004	Olson	.....	D12/217
D552,527 S *	10/2007	Wolfram	.....	D12/217
D609,158 S *	2/2010	Bird	.....	D12/217
8,499,899 B2 *	8/2013	Scott	.....	B60T 3/00 188/32
8,657,078 B2 *	2/2014	Wolfram	.....	B60T 3/00 188/36

D772,775 S *	11/2016	Bird	.....	D12/223
D775,579 S *	1/2017	Hughes	.....	D12/217
D859,278 S *	9/2019	White	.....	D12/217
2008/0277211 A1 *	11/2008	Wolfram	.....	B60T 3/00 188/32
2011/0100765 A1 *	5/2011	Bird	.....	B60T 3/00 188/32
2019/0202418 A1 *	7/2019	Waddell	.....	B60T 3/00

\* cited by examiner

*Primary Examiner* — Stacia A Cadmus

(74) *Attorney, Agent, or Firm* — Imperium Patent Works;  
Amir V. Adibi; Andrew C. Palmer

(57) **CLAIM**

The ornamental design for the wheel chock, as shown and described.

**DESCRIPTION**

FIG. 1 is a front perspective view of a vehicle wheel chock showing my new design;  
 FIG. 2 is a front view thereof;  
 FIG. 3 is a back view thereof;  
 FIG. 4 is a left side view thereof, the right side view being a mirror image thereof;  
 FIG. 5 is a top plan view thereof;  
 FIG. 6 is a bottom plan view thereof;  
 FIG. 7 is a front perspective view of the wheel chock shown in its position of use; and,  
 FIG. 8 is a right side view of the wheel chock shown in its position of use.  
 In the drawings the broken lines depict environmental subject matter and form no part of the claimed design.

**1 Claim, 8 Drawing Sheets**

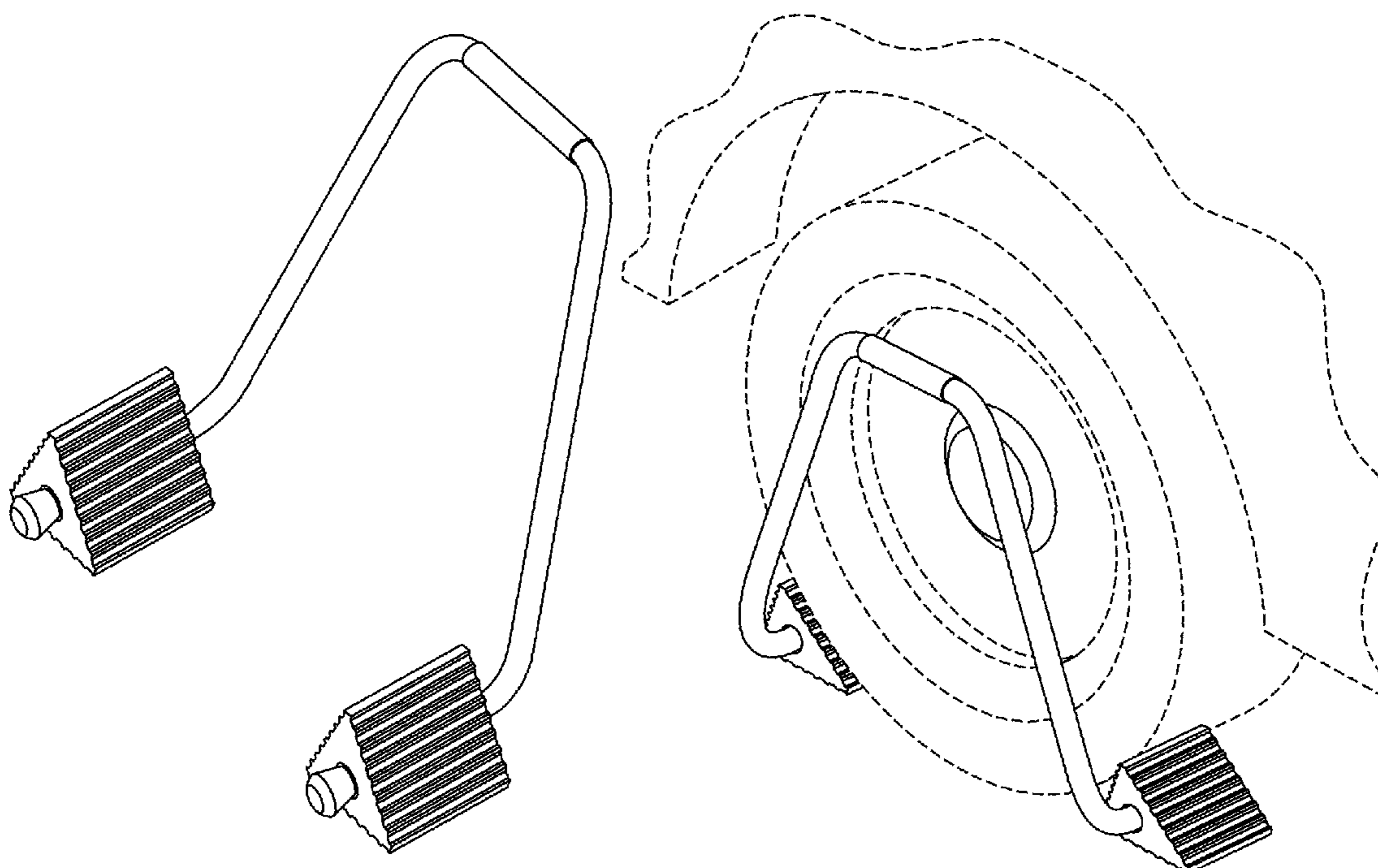

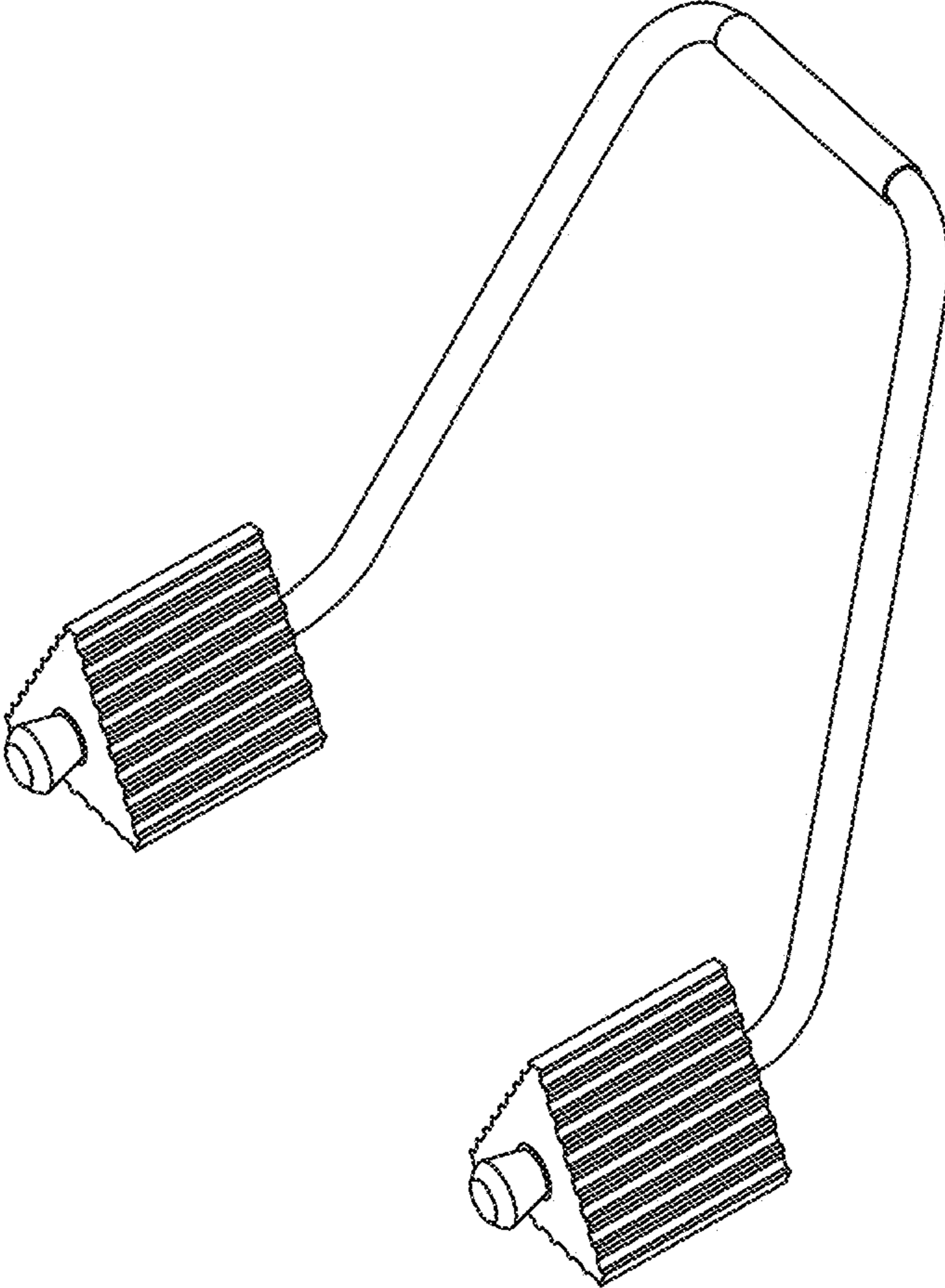

FIG. 1

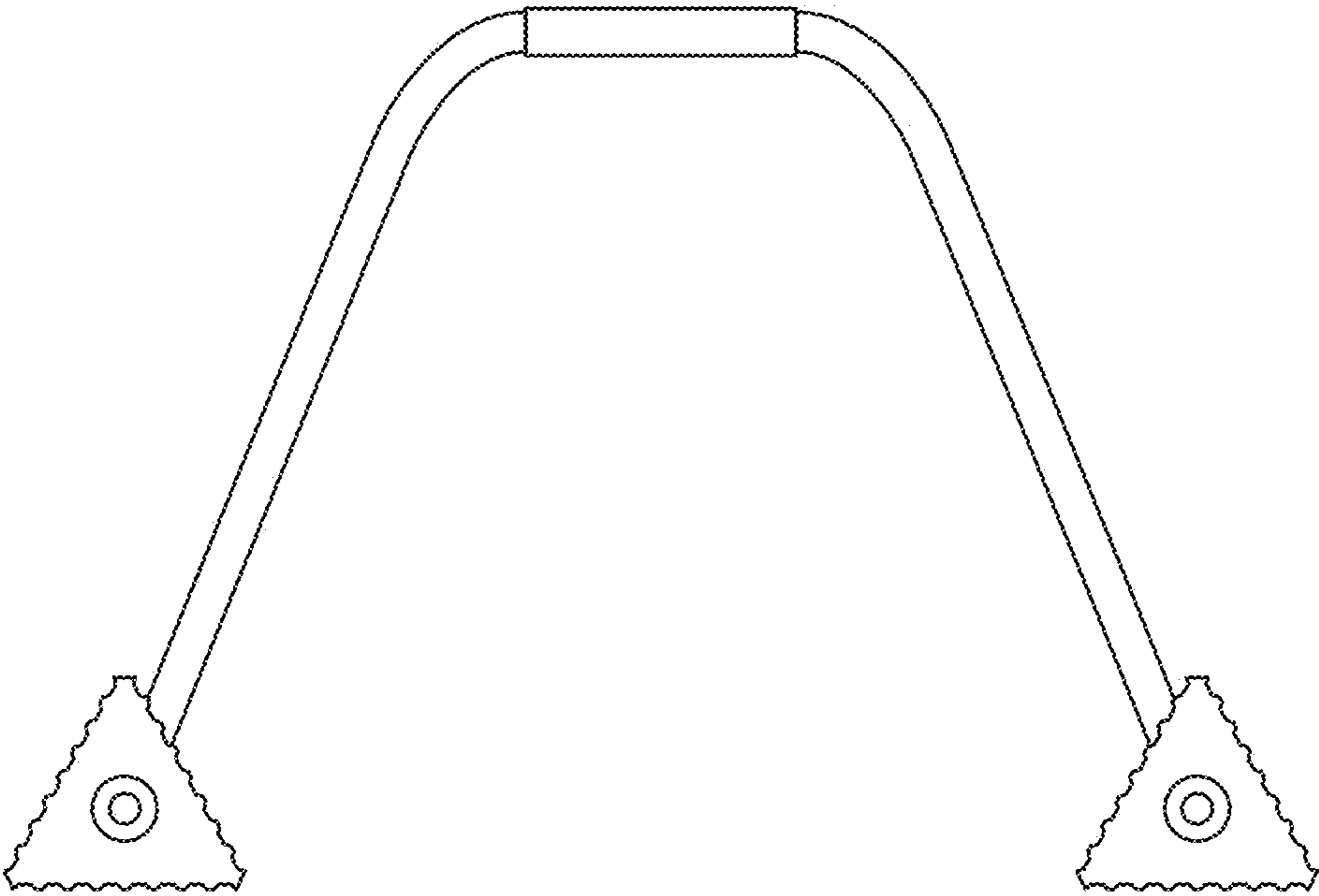

FIG. 2

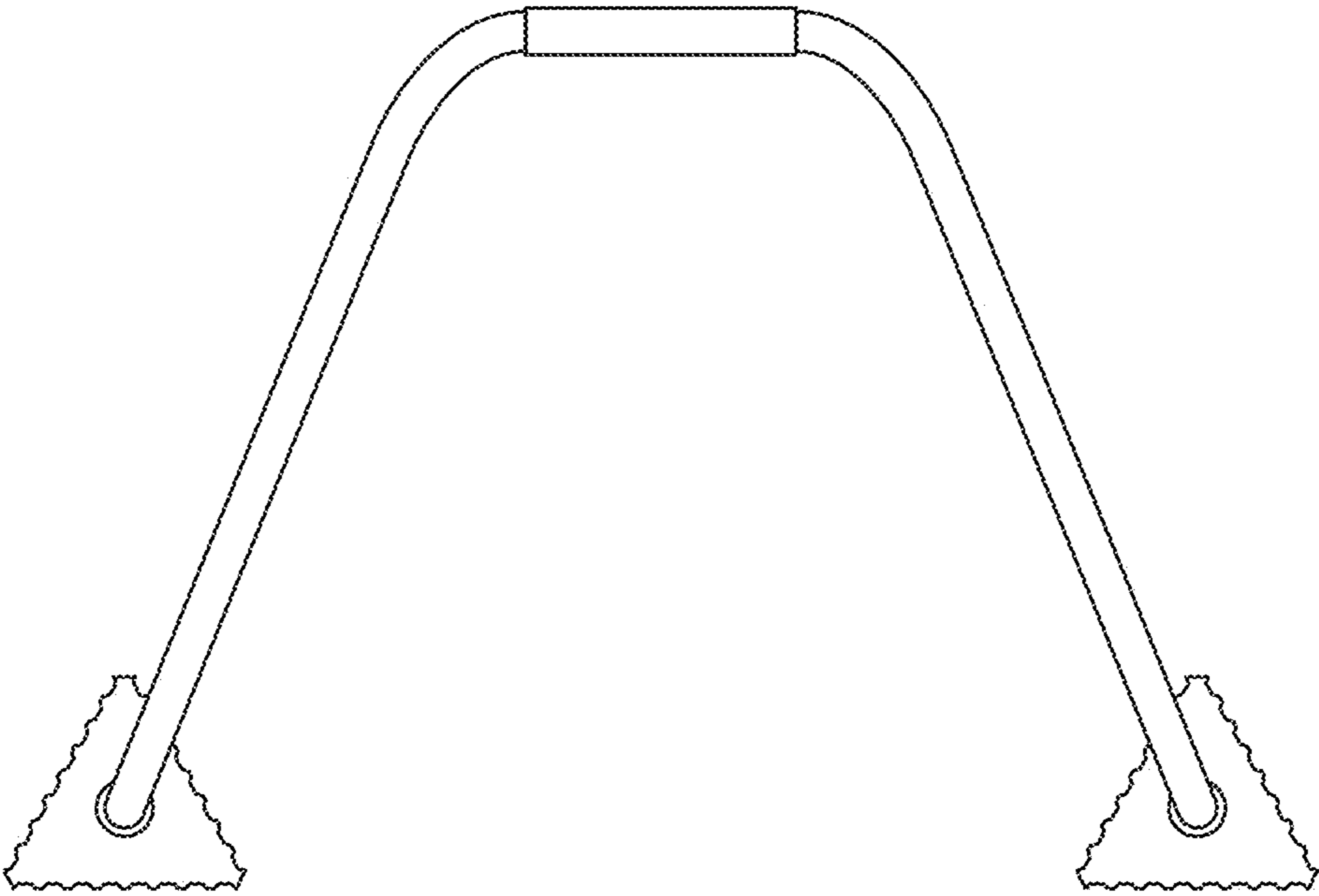

FIG. 3

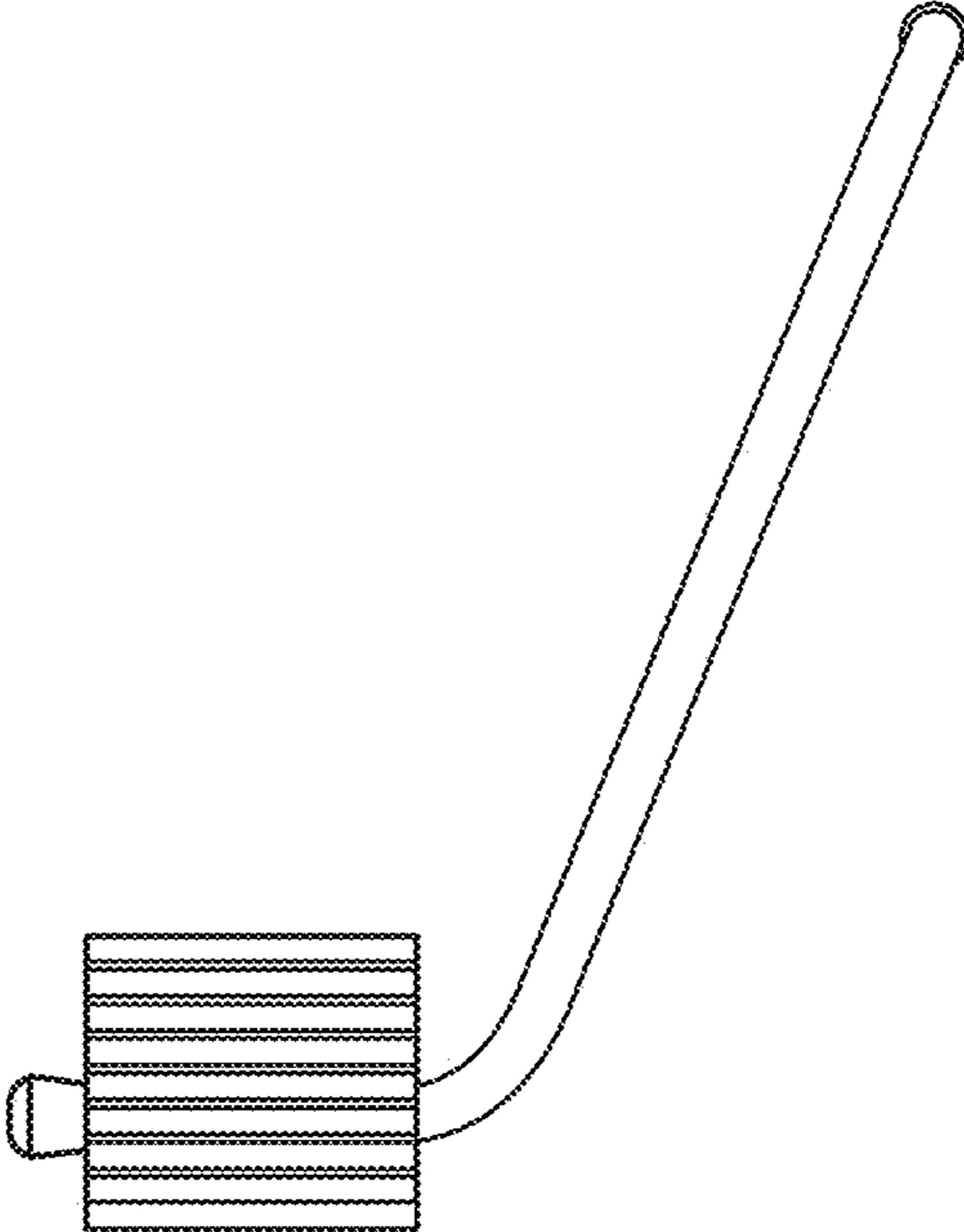

FIG. 4

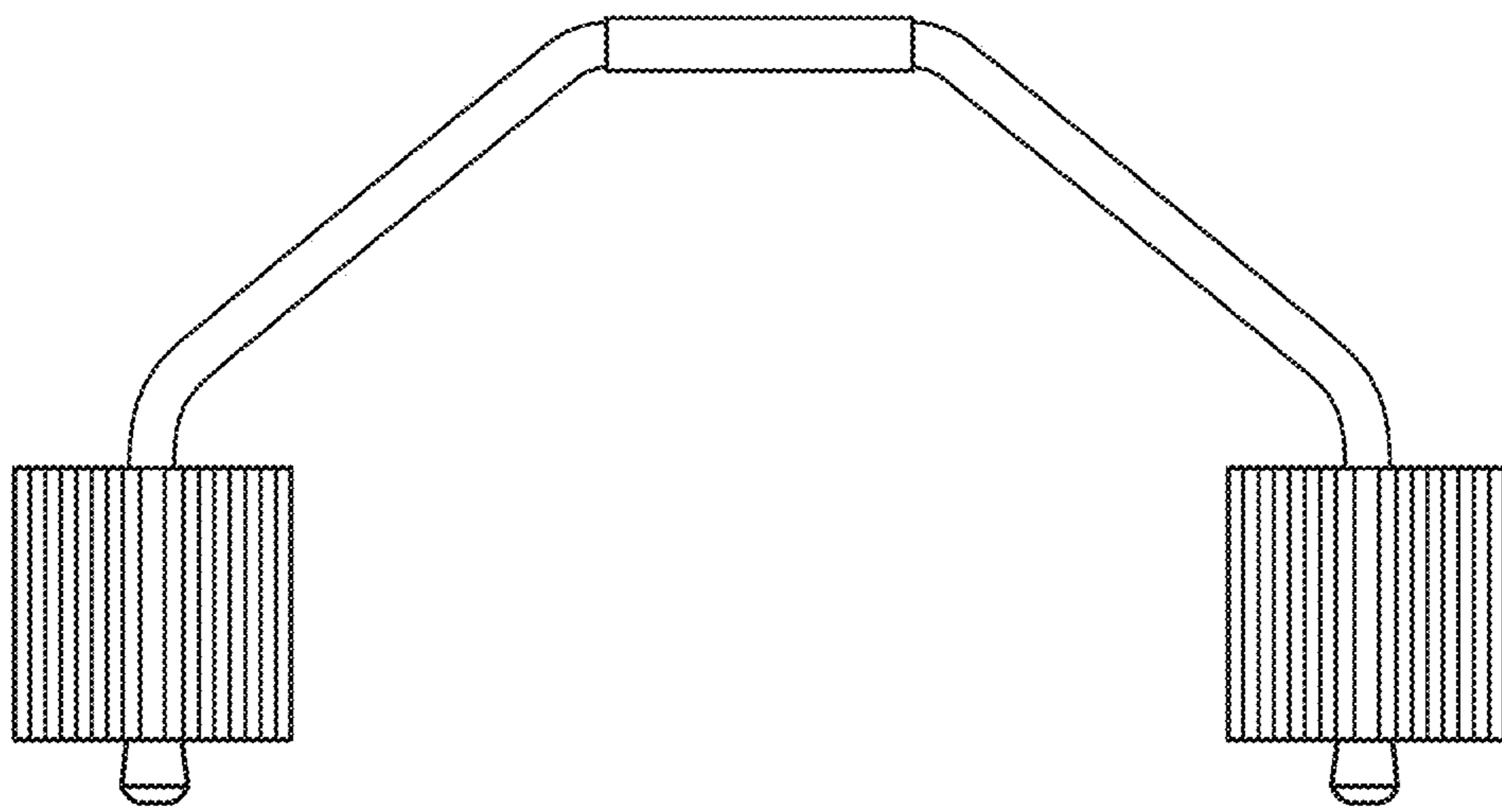

FIG. 5

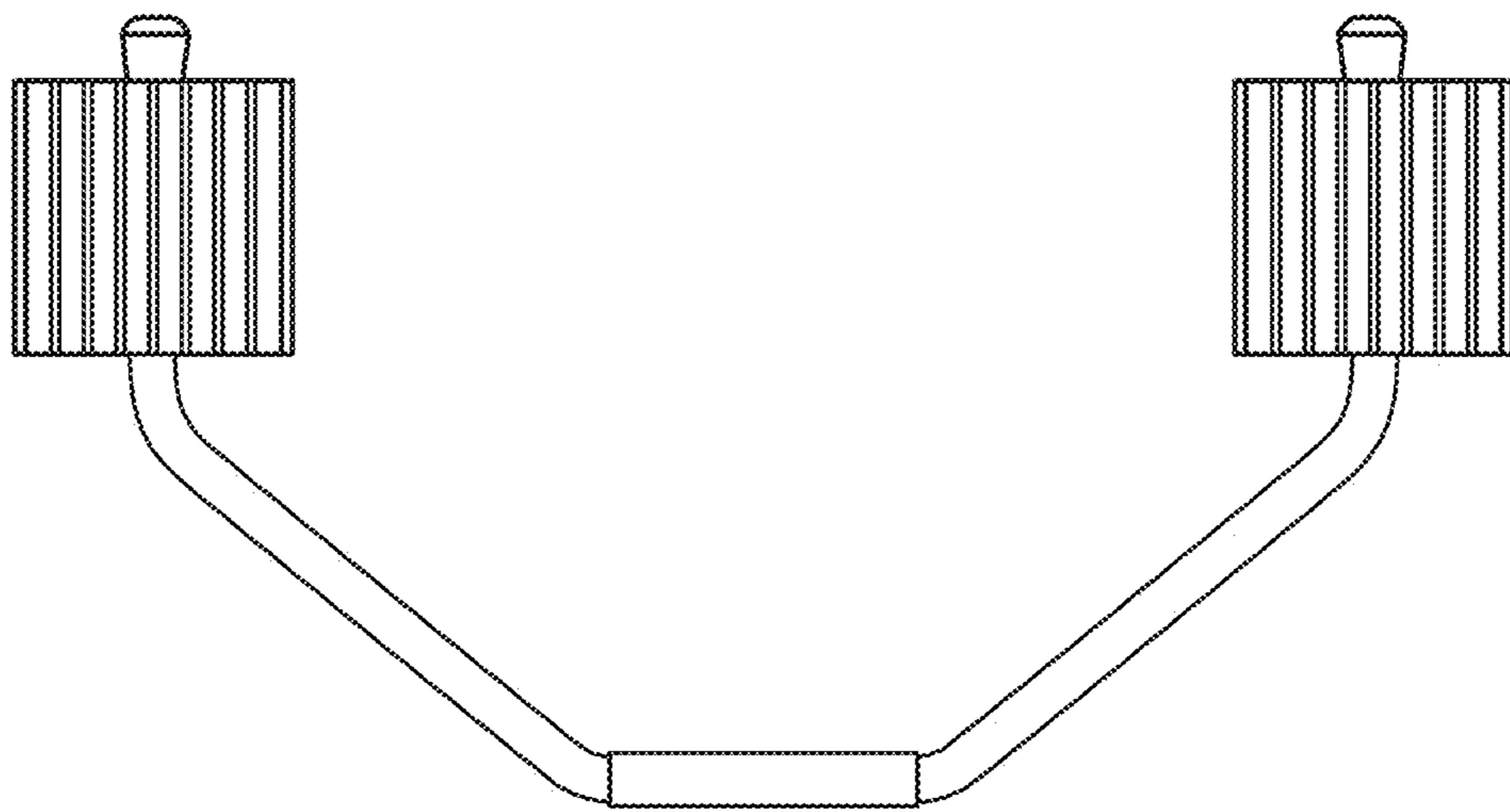

FIG. 6

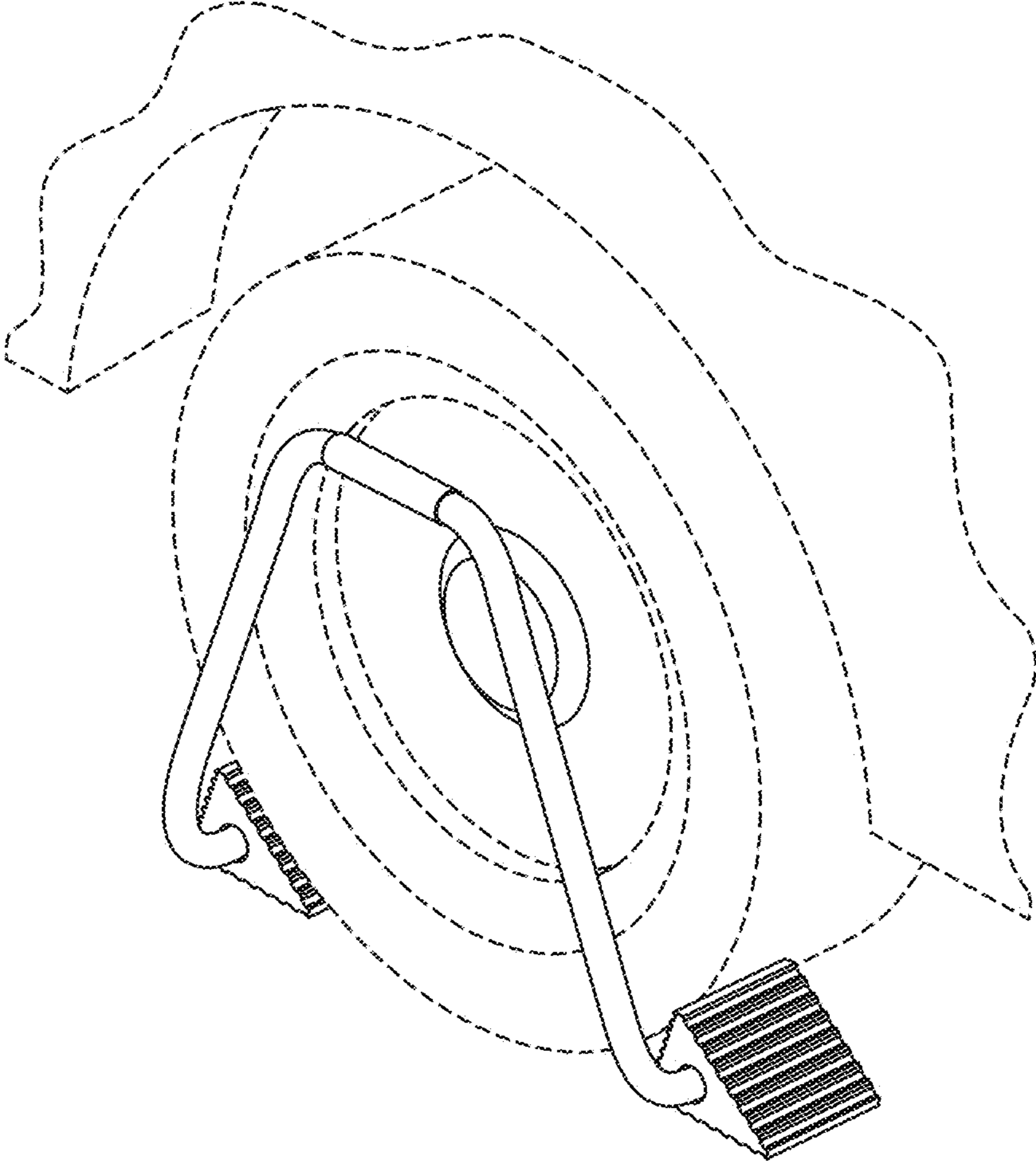

FIG. 7



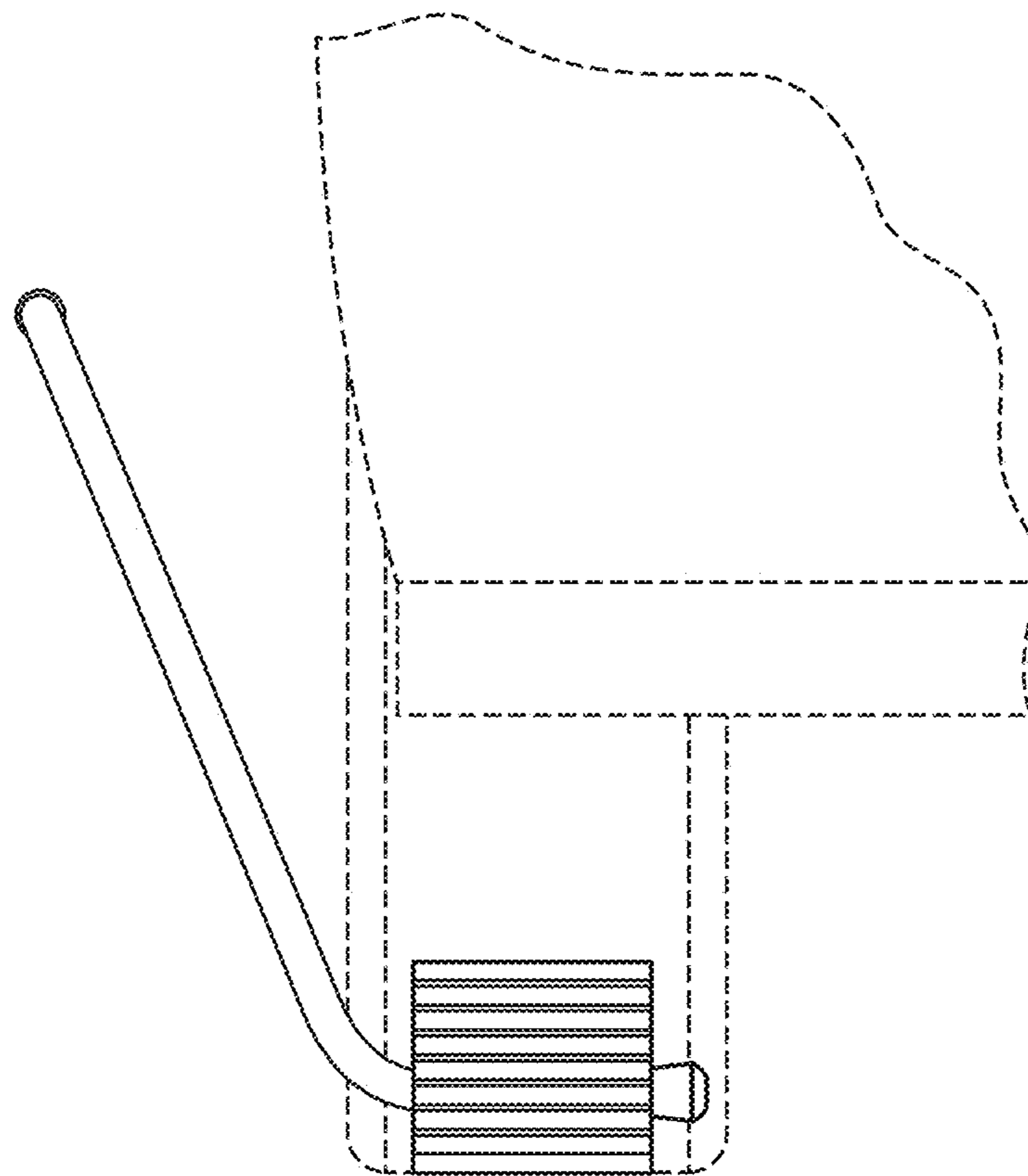

FIG. 8