



US00D873195S

(12) **United States Design Patent**
Hall et al.

(10) **Patent No.:** **US D873,195 S**

(45) **Date of Patent:** **** *Jan. 21, 2020**

(54) **AUTOMOTIVE WHEEL**

(71) Applicants: **David R. Hall**, Provo, UT (US);
Stephen R. Hall, Draper, UT (US);
Christopher Johnson, Provo, UT (US);
Jason Simpson, Provo, UT (US)

(72) Inventors: **David R. Hall**, Provo, UT (US);
Stephen R. Hall, Draper, UT (US);
Christopher Johnson, Provo, UT (US);
Jason Simpson, Provo, UT (US)

(73) Assignee: **Hall Labs LLC**, Provo, UT (US)

(*) Notice: This patent is subject to a terminal disclaimer.

(**) Term: **15 Years**

(21) Appl. No.: **29/590,865**

(22) Filed: **Jan. 13, 2017**

(51) **LOC (12) Cl.** **12-16**

(52) **U.S. Cl.**
USPC **D12/209**

(58) **Field of Classification Search**
USPC D12/204–213; D21/533, 561, 563
CPC B60B 7/00; B60B 7/02; B60B 7/04; B60B 7/06;
B60B 3/02; B60B 3/04; B60B 3/06;
B60B 3/10; B60B 1/00; B60B 1/08;
B60B 1/10; B60B 1/12

See application file for complete search history.

(56) **References Cited**

U.S. PATENT DOCUMENTS

D90,802 S	*	10/1933	Crane	301/37.22
D318,256 S	*	7/1991	Brinkmann	D12/211
D340,438 S	*	10/1993	Sheeler	D12/209
D403,645 S	*	1/1999	Chung	D12/209
D405,410 S	*	2/1999	Goplen	D12/211
D442,904 S	*	5/2001	Herrera	D12/207
D726,084 S	*	4/2015	Chu	D12/204
D801,253 S	*	10/2017	Taylor	D12/211
D808,882 S	*	1/2018	Taylor	D12/211

* cited by examiner

Primary Examiner — Sheryl Lane

Assistant Examiner — Calvin E Vansant

(57) **CLAIM**

The ornamental design for an automotive wheel, as shown and described.

DESCRIPTION

FIG. 1 is a left, rear-isometric view of the wheel showing a first spoke assembly;

FIG. 2 is a right, rear-isometric view of the wheel showing a second spoke assembly; and

FIG. 3 is an exploded view of the wheel; and,

FIG. 4 is a cross-sectional view of the wheel.

The broken lines depict unclaimed portions of the automotive wheel and form no part of the claim.

1 Claim, 4 Drawing Sheets

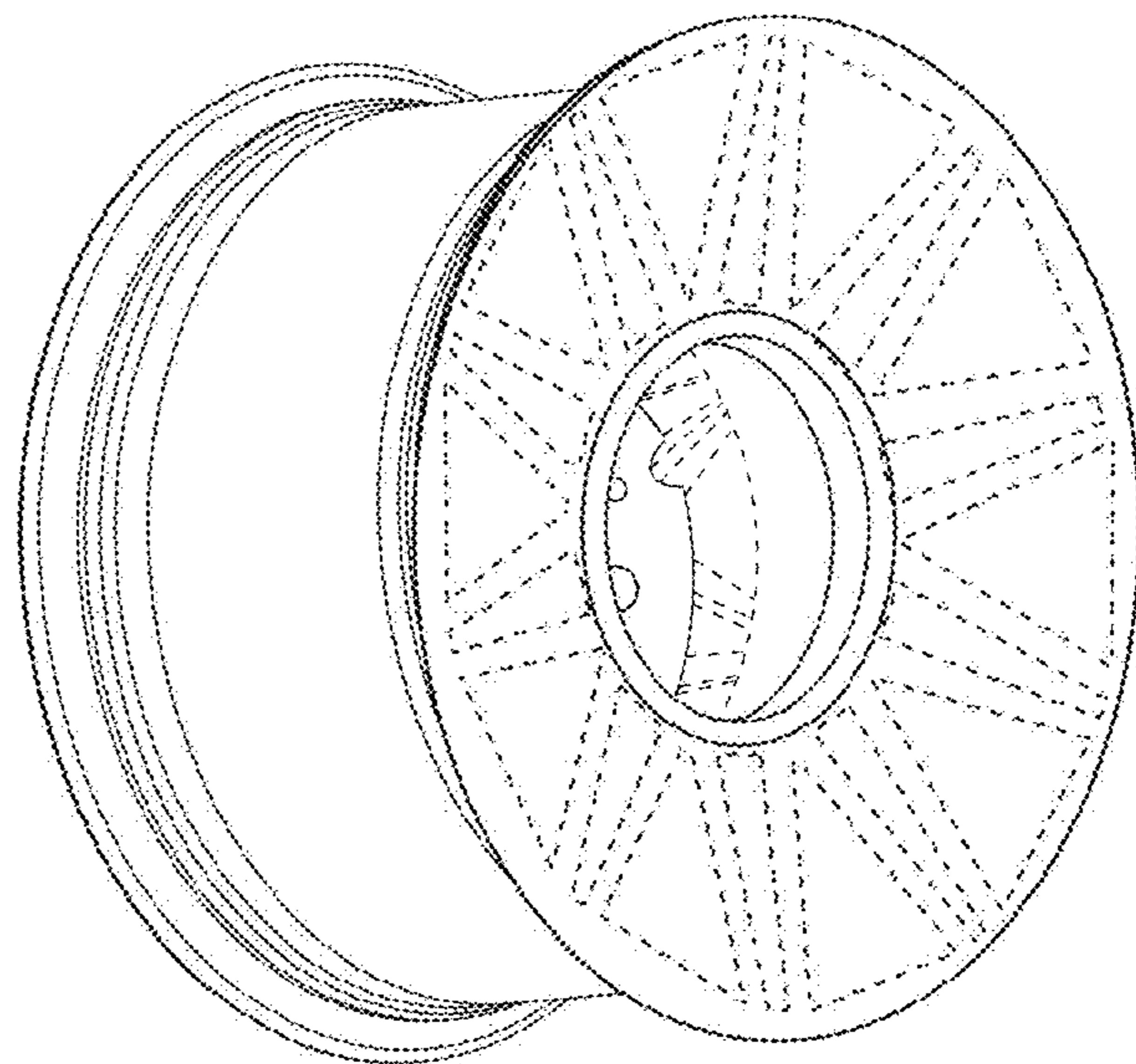
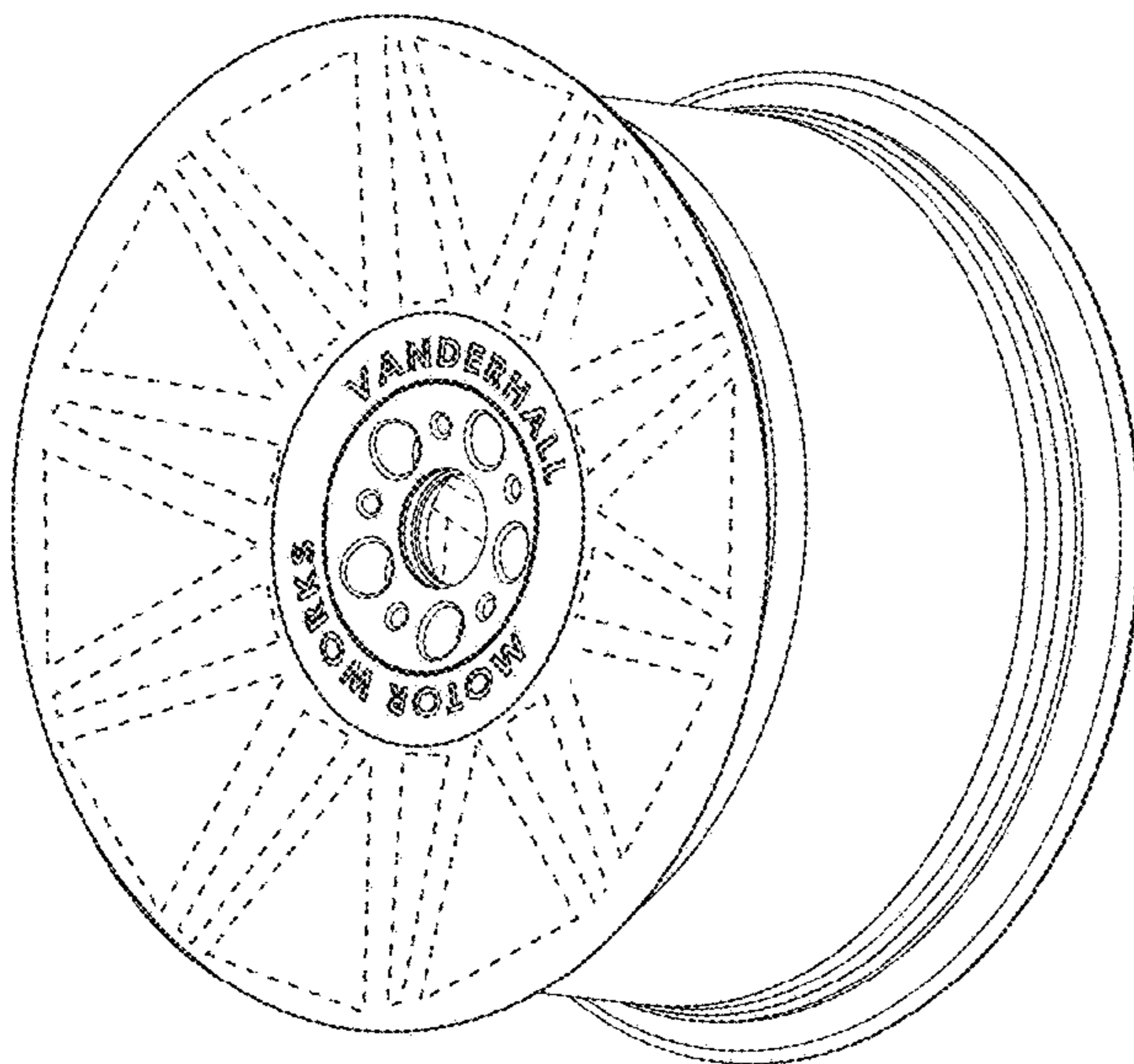

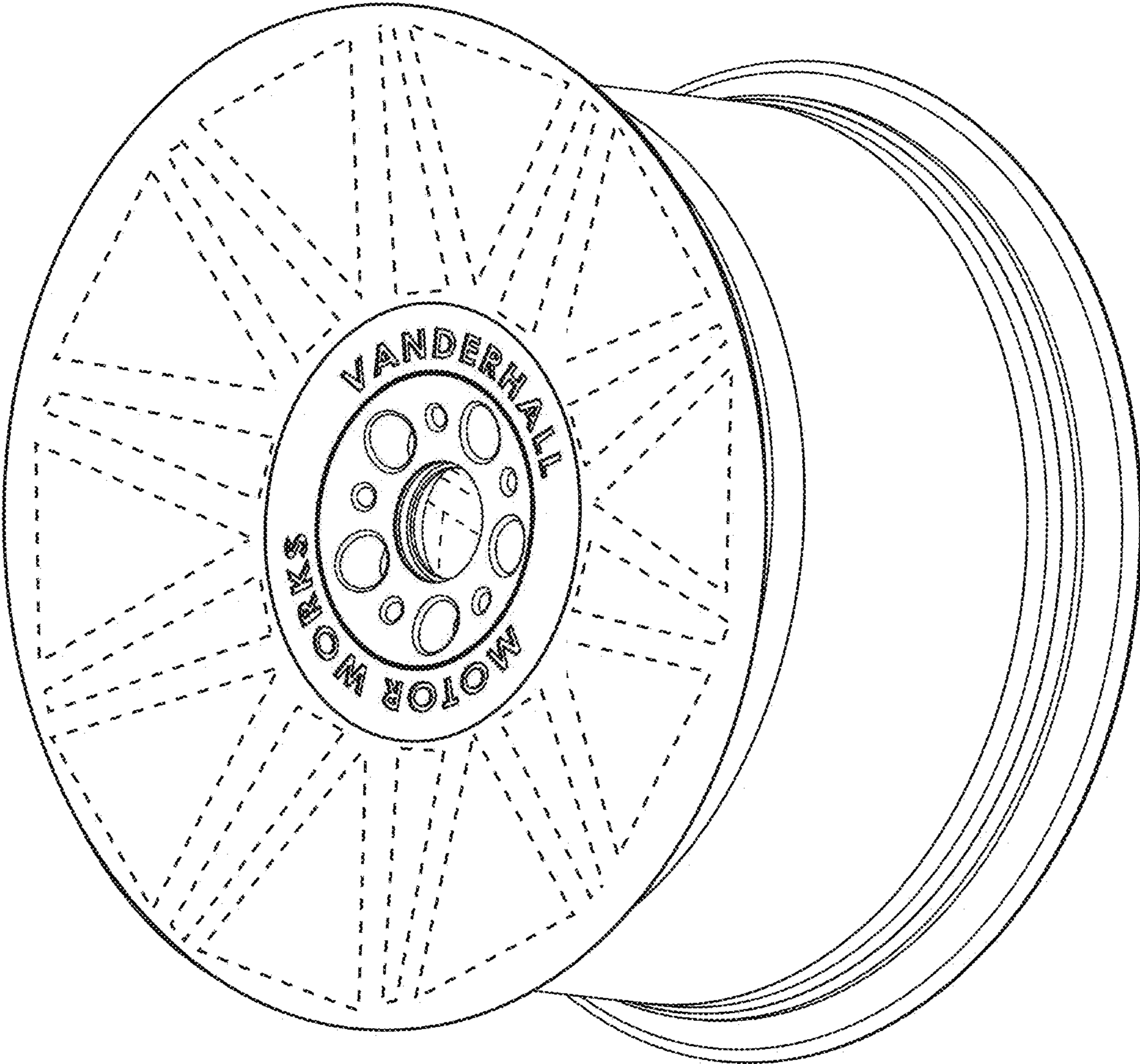

FIG. 1

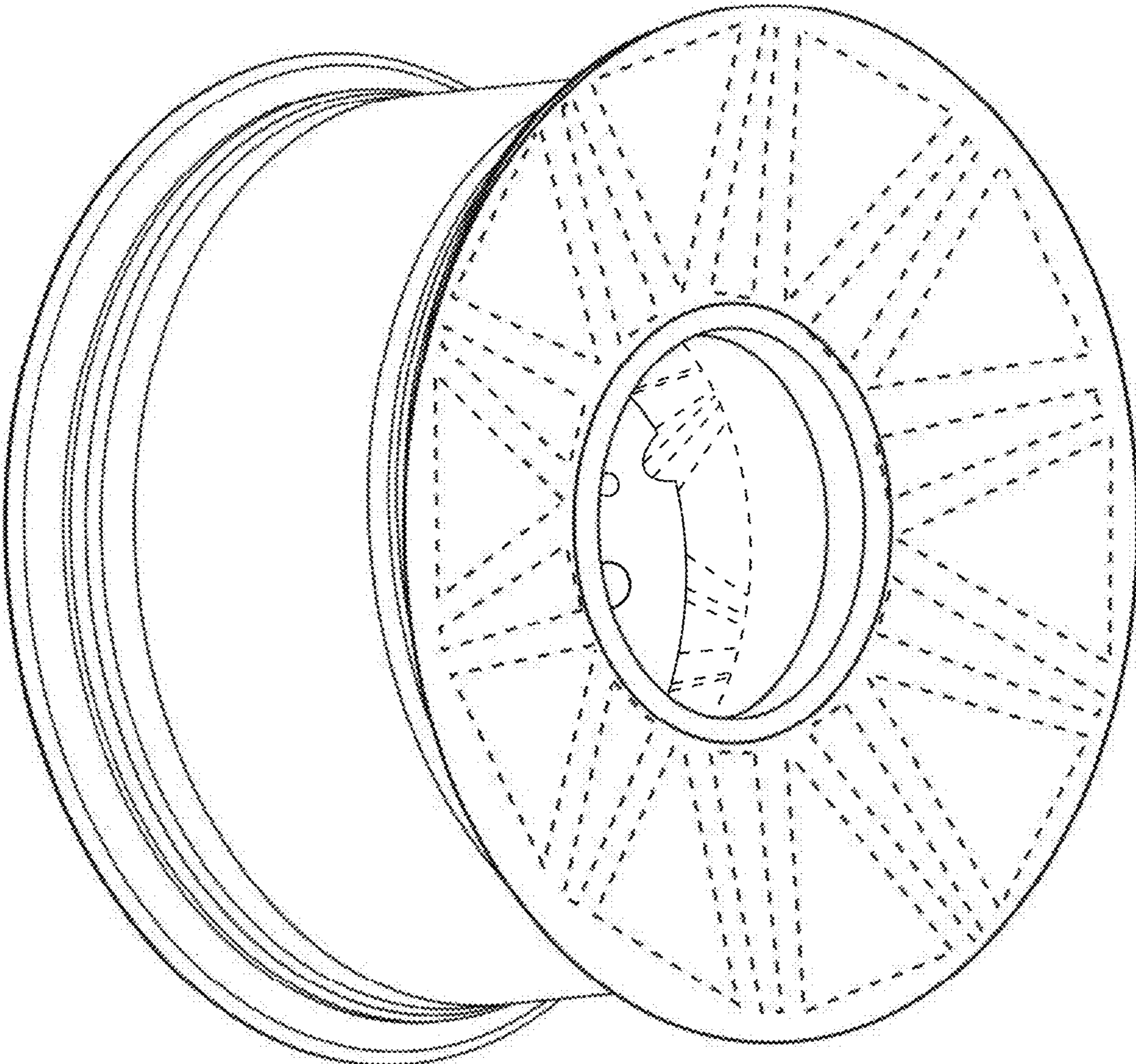

FIG. 2

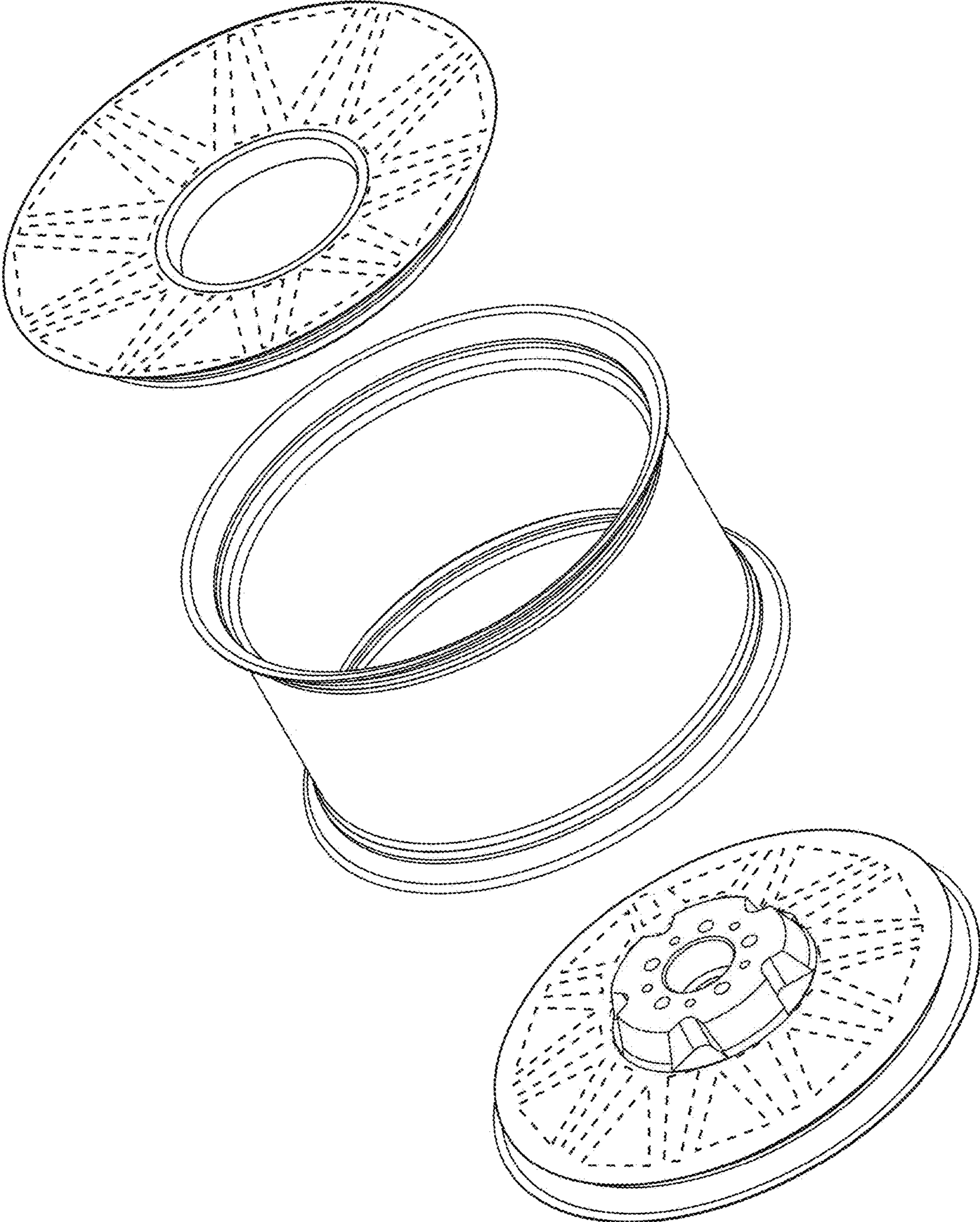

FIG. 3

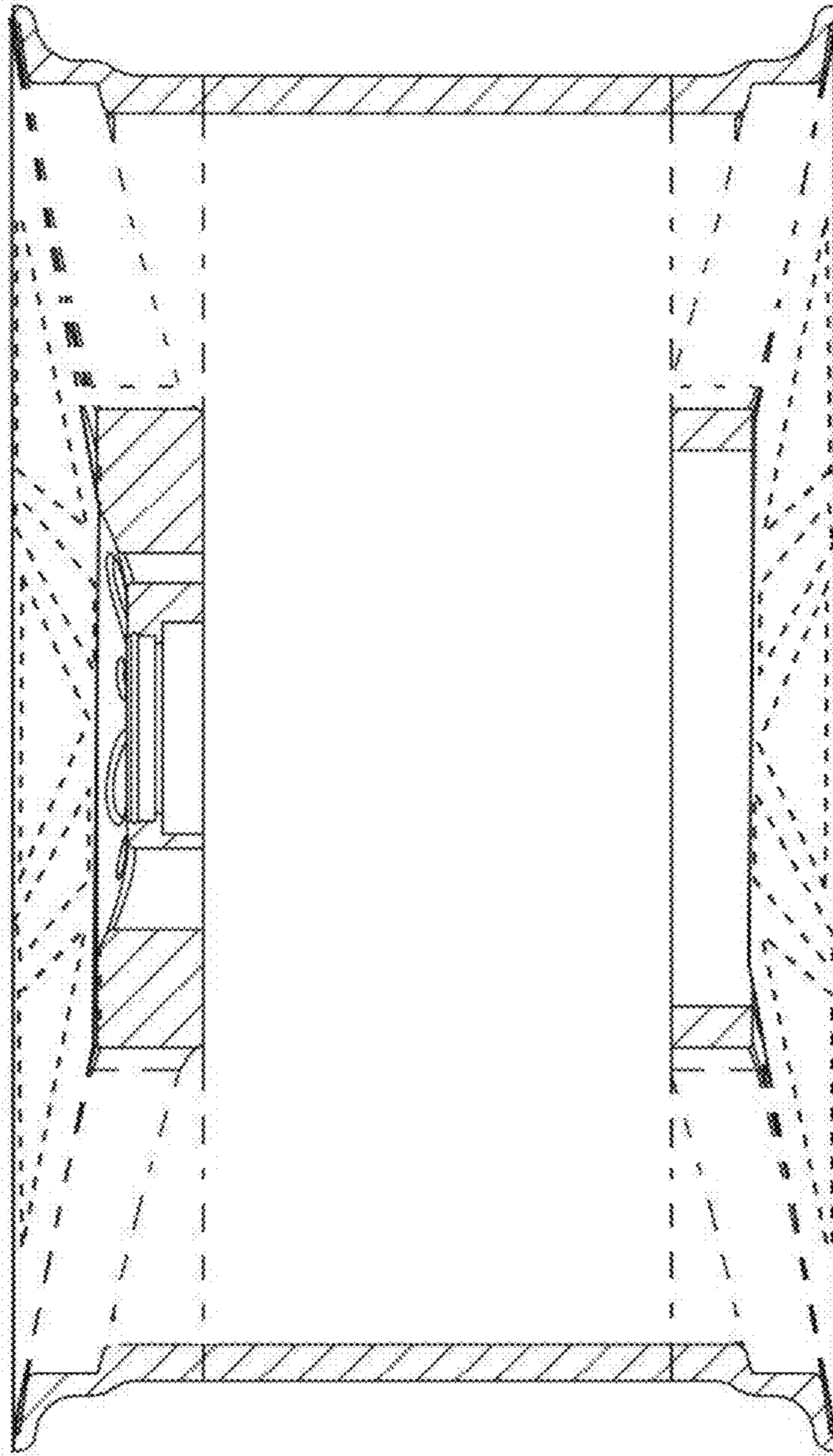

FIG. 4